

LG938轮式装载机 零部件图册

LG938 WHEEL LOADER PARTS CATALOG

山东临工工程机械有限公司

SHANDONG LINGONG CONSTRUCTION MACHINERY CO.,LTD.

配件与服务 Spare parts and services

对于山东临工机器的所有者来说,只有山东临工配件和服务才能够使您的机器更好地保持原有的特性。

For the owner of the machines of SDLG,only the spare parts and services of SDLG can make your machine to better maintain the original features.

只有山东临工才能够为您提供完美匹配且优质纯正的配件和对您的机器了如指掌的专业维修人员。这样才能保证及其可持续的高产能和更长的使用寿命。

Only SDLG is able to provide you with the perfect match of pure quality spare parts for your machine and knowledge of professional maintenance staff.Only in this way it can ensure sustainable high productivity and longer service life.

LG938轮式装载机 零部件图册 LG938 WHEEL LOADER PARTS CATALOG

2010年12月 第1版 第1次印刷

2010-12 Version 1 Printed 1

山 东 临 工 工 程 机 械 有 限 公 司
SHANDONG LINGONG CONSTRUCTION MACHINERY CO.,LTD.

地址: 中国·临沂经济开发区临工工业园

Add: Lingong Industry Park,Linyi Economic Development Zone,Shandong,China

电话: 86-0539-8785668

Tel: 86-0539-8785624/86-0531-66590955

传真: 86-0539-8785698

Fax: 86-0539-8785618/86-0531-66590959

技术服务: 86-0539-8785800 400-6587999

Web: www.sdlg.cn

前言

LG953轮式装载机零部件图册，是为了方便用户使用、维修和保养而绘制的，以供在使用过程中查阅及参考，也可帮助用户了解本机的结构和装配关系。发动机的零部件详见其随机资料，本图册不再绘出。

本图册按系统划分绘制出了各零部件的图形及相互装配关系。凡装机后不可拆卸的部件（如焊接件、铆合件），只标出部件代号，不另列其组成零件。本图册明细表采用中英文对照编排。

本图册主要根据标准型产品(订货号E3805215A3908)编绘，其它非标准配置，可参照执行，详情请咨询山东临工、或当地经销商、或登录山东临工网站查询。随着科技的进步，产品将会不断改进，故本图册的内容可能会有部分与以后的产品不一致，恕不另行通知。敬请用户在订购配件时，指明所购整车的出厂日期和编号。

编者

2010年12月

FOREWORD

THIS PARTS LIST OF LG953 WHEEL LOADER IS MADE FOR THE CONVENIENCE OF USERS TO USE ,REPAIR AND MAINTAIN THE MACHINE,AND IT CAN BE REFERED IN THE PROCESS OF USING.IT CAN ALSO HELP THE USERS TO BE FAMILIAR WITH THE CONSTRUCTION AND ASSEMBLY RELATION OF THE MACHINE. THE PART OF THE ENGINE IS SHOWED IN DETAIL IN ITS STRUCTION HANDBOOK.SO THIS CATALOG DOES NOT CONTAIN THE ENGING PART LIST.

THE CATALOG CONTAINS THE PART DRAWINGS OF DEFERENT ASSEMBLIES,SHOWING THE SHAPE OF THE PARTS AS WELL AS THE ASSEMBLING RELATION.THE COMPONENTS WHICH CAN NOT BE TAKEN APART (SUCH AS THE WELDMENT OR RIVETED ASSEMBLIES) ARE INDICATED ONLY BY THEIR COMPONET NUMBERS WITHOUT THE CONSISTING PART NUMBERS .THE LIST IN THE CATALOG IS ARRANGED BY CHINESE VERSUS ENGLISH.

THIS CATALOG IS MAINLY BASED ON THE STANDARD PRODUCT(ORDER NUMBER E3805215A3908) THE OTHERS OF NONSTANDARD PRODUCT CAN REFER THE STANDARD PRODUCT,AND THE DETAILED INFORMATION CAN BE KNOWN FROM SHANDONG LINGONG,THE LOACAL DEALER OR LINGONG WEBSITE ALTERATIONS IN DESIGN ARE NECESSARILY WITH THE THECHNICAL DEVELOPMENT SO SOME CONTENT IN THE CATALOG PROBABLY IS NOT CONSISTANT WITH THE FUTURE PRODUCTS,AND THIS WILL NOT NOTICE USERS.THEREFORE WHEN ORDERING SPARE PARTS, USERS ARE KINDLY REQUSETED TO INFORM US THE MANUFACTURING DATE AND BATCHNUMBER OF THE WHEEL LOADER.

THE COMPILER

2010.12

目录 CONTENTS

A. 发动机系统

A. DIESEL ENGINE SYSTEM

发动机总成	A1-2901000918
DIESEL ENGINE ASSEMBLY	A1-2901000918
燃油箱总成	A2-2902000758
FUEL TANK ASSEMBLY	A2-2902000758
散热器总成	A3-2903000777
RADIATOR ASS'Y	A3-2903000777
油门操纵机构	A4-2901001188
GOVERNOR CONTROL SYSTEM	A4-2901001188
散热器总成（配高温冷却模块）	A5-2903000777
RADIATOR ASS'Y(HIGH-TEMPERATURE COOLING MODULES)	A5-2903000777

C. 变速箱系统

C. TRANSMISSION SYSTEM

变速箱系统	C1-2905001043
TRANSMISSION SYSTEM	C1-2905001043
箱体部件	C2-4110000076
CASE PARTS	C2-4110000076
输入部件	C3-4110000076
INPUT PARTS	C3-4110000076

输出部件	C4-4110000076
OUTPUT PARTS	C4-4110000076
操纵部件	C5-4110000076
CONTROL PARTS	C5-4110000076
转速表部件	C6-4110000076
SPEED INDICATOR PARTS	C6-4110000076
惰轮部件	C7-4110000076
IDLER PARTS	C7-4110000076
停车制动器部件	C8-4110000076
STOP BRAKE STAFF PARTS	C8-4110000076
压力阀部件	C9-4110000076
PRESSURE VALVE PARTS	C9-4110000076
吸油管部件	C10-4110000076
OIL SUCTION TUBE PARTS	C10-4110000076
发动机连接部件	C11-4110000076
ENGINE CONNECTION PARTS	C11-4110000076
加油管部件	C12-4110000076
OIL FILLING TUBE PARTS	C12-4110000076
滤油器部件	C13-4110000076
OIL FILTER PARTS	C13-4110000076

离合器部件	C14-4110000076
CLUTCH PARTS	C14-4110000076
离合器部件	C15-4110000076
CLUTCH PARTS	C15-4110000076
离合器部件	C16-4110000076
CLUTCH PARTS	C16-4110000076
PTO1部件P.T.02	C17-4110000076
PTO1 PARTS P.T.02	C17-4110000076
PTO2部件P.T.02	C18-4110000076
PTO2 PARTS P.T.02	C18-4110000076
操纵阀部件	C19-4110000076
CONTROL VALVE PARTS	C19-4110000076

E. 驱动桥系统

E. AXLE SYSTEM

前主传动总成	E2-2050900006
FRONT AXLE MAIN DRIVE ASSEMBLY	E2-2050900006
轮边减速器总成	E3-2050900004
FINAL DRIVE ASSEMBLY	E3-2050900004
后主传动总成	E6-2050900033
REAR AXLE MAIN DRIVE ASSEMBLY	E6-2050900033



制动钳(371328)	E8-4120001739
DISK BRAKE(371328)	E8-4120001739
驱动桥系统	E9-2907000915
AXLE SYSTEM	E9-2907000915
轮胎GB2980-23.5-25 (520101)	E11-4110000003
TIRE GB2980-23.5-25 (520101)	E11-4110000003

F. 工作装置液压系统

F. IMPLEMENT HYDRAULIC SYSTEM

液压操纵总成	F1-2912001445
HYDRAULIC CONTROL ASSEMBLY	F1-2912001445
工作泵总成	F2-2911000828
WORKING PUMP ASSEMBLY	F2-2911000828
举升缸总成	F3-2913000829
LIFTING CYLINDER ASSEMBLY	F3-2913000829
转斗缸总成	F4-2914000836
TILT CYLINDER ASSEMBLY	F4-2914000836
液压油箱总成	F5-2910000950
HYDRAULIC TANK ASSEMBLY	F5-2910000950
转斗油缸(371368)	F7-4120001083
DUMP CYLINDER	F7-4120001083

动臂油缸（371368）	F9-4120000867
LIFT ARM CYLINDER	F9-4120000867
多路阀(331001)	F11-4120001054
CONTROL VALVE	F11-4120001054
H. 工作装置	
H. WORKING EQUIPMENT	
工作装置	H3-2915000876
WORKING EQUIPMENT	H3-2915000876
I. 转向系统	
I. STEERING SYSTEM	
转向泵总成	I1-2919000780
STEERING PUMP ASSEMBLY	I1-2919000780
转向器总成	I2-2920000806
STEERING UNIT ASSEMBLY	I2-2920000806
转向缸总成	I3-2921000401
STEERING CYLINDER ASSEMBLY	I3-2921000401
转向油缸（371368）	I5-4120001004
STEERING CYLINDER	I5-4120001004
J. 制动系统	
J. BRAKE SYSTEM	

行车制动系统	J1-2922000768
SERVICE BRAKE ASSEMBLY	J1-2922000768
储气罐	J2-2922000053
AIR RESERVOIR	J2-2922000053
加力泵（340201）	J3-4120000090
BRAKE BOOSTER	J3-4120000090
驻车制动系统	J4-2923000758
PARKING BRAKE SYSTEM	J4-2923000758

K. 车架

K. FRAME

前车架总成	K1-2925000419
FRONT FRAME	K1-2925000419
左、右灯架	K3-2934001225
LAMP FRAME AND FRONT FENDER	K3-2934001225
后车架及配件	K4-2926000837
REAR FRAME AND ACCESSORIES	K4-2926000837
配重铁总成	K5-2928000751
COUNTER WEIGHT	K5-2928000751

L. 驾驶室

L. CAB GROUP

驾驶室总成	L1-2929000774
CAB ASSEMBLY	L1-2929000774
驾驶室	L2-2929000004
CAB	L2-2929000004
操作台架	L3-2931001099
OPERATE BENCH	L3-2931001099
座椅总成	L4-2930000001
SEAT ASSEMBLY	L4-2930000001
操纵箱总成	L5-2932000858
OPERATE CASE	L5-2932000858

M. 覆盖件系统

M. CONVER SYSTEM

发动机罩总成	M1-2933001095
HOOD OF DIESEL ENGINE ASSEMBLY	M1-2933001095
左台架总成	M2-2934001213
LEFT BENCH ASSEMBLY	M2-2934001213
右台架总成	M3-2934000850
RIGHT BENCH ASSEMBLY	M3-2934000850
标志与标识	M5-2936000957
MARK AND LOGO	M5-2936000957

电瓶箱总成	M6-2934001071
BATTERY CASE ASSEMBLY	M6-2934001071
下梯总成	M7-2934001219
DOWN LADDER ASSEMBLY	M7-2934001219
N. 空调系统	
N. AIR CONDITIONER SYSTEM	
空调系统	N2-2935000778
AIR CONDITIONER SYSTEM	N2-2935000778
O. 电气系统	
O. ELECTRIC SYSTEM	
电气系统	O1-2937000775
ELECTRIC SYSTEM	O1-2937000775
仪表盘总成	O2-2937001217
PANEL ASSEMBLY	O2-2937001217
仪表台总成	O3-2937001271
PANEL ASSEMBLY	O3-2937001271

A 发动机系统
DIESEL ENGINE SYSTEM

山东临工工程机械有限公司
SHANDONG LINGONG CONSTRUCTION MACHINERY CO.,LTD.

发动机总成 DIESEL ENGINE ASSEMBLY

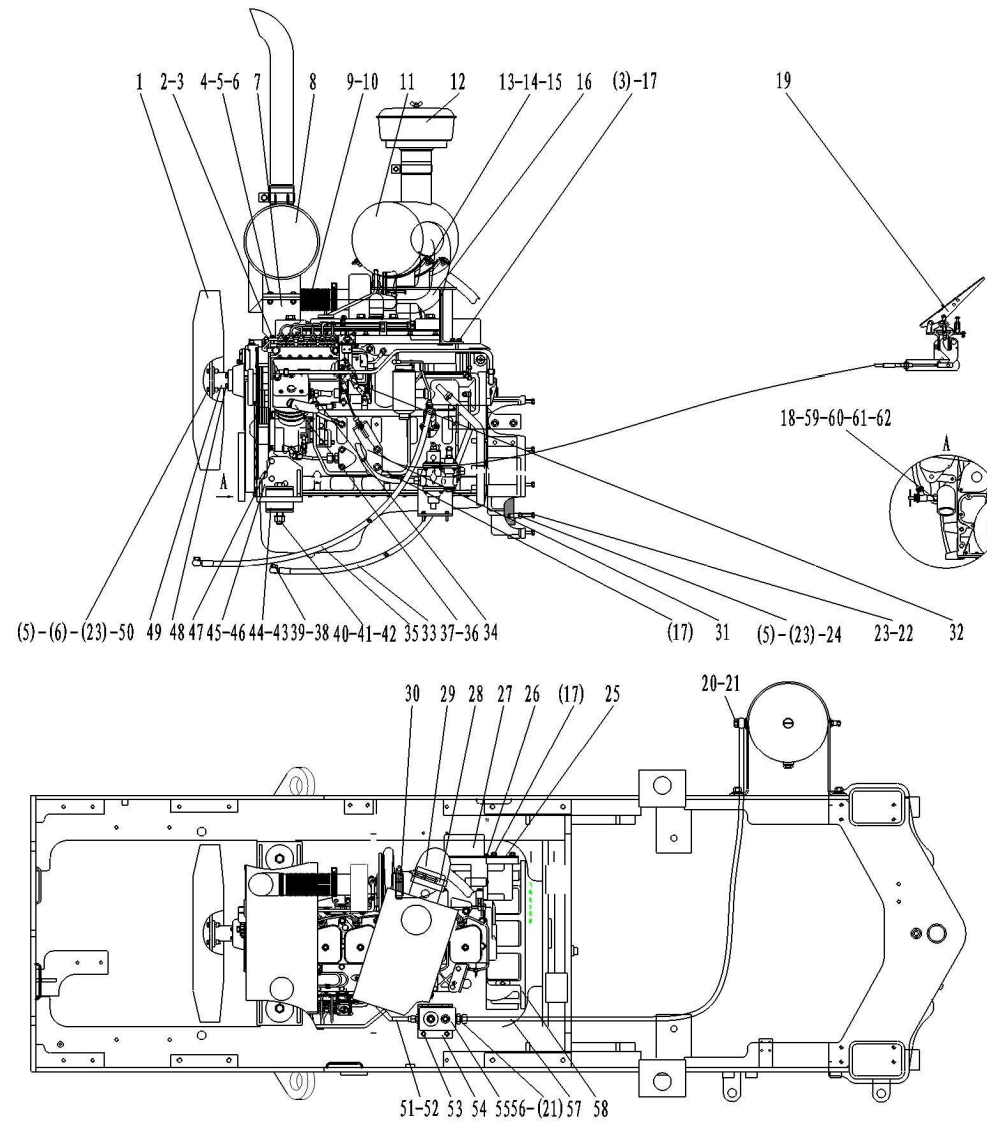

序号 Key	零件代号 Part No.	名称 Description	是否配件 Spare parts Y/N	数量 Qty	备注 Remarks
1	4190000138	风扇610/7-7/32.5/PAG/2ZR/25.4/4*10/BC60	FAN	Y	1
2	4011000164	螺栓GB16674-M10*35EpZn-8.8	BOLT GB16674-M10*35EpZn-8.8	N	3
3	4011000474	螺栓GB16674-M10*25EpZn-8.8	BOLT GB16674-M10*25EpZn-8.8	N	4
4	4011000085	螺栓GB5783-M10*35EpZn-8.8	BOLT GB5783-M10*35EpZn-8.8	N	4
5	4013000007	螺母GB6170-M10EpZn-8	NUT GB6170-M10EpZn-8	N	16
6	4015000162	垫圈GB97.1-10EpZn-300HV	WASHER GB97.1-10EpZn-300HV	N	12
7	29010009351	消声器支架	FRAME	Y	1
8	4110000187	消声器总成XH.G402X.W	DISSIPATIVE MUFFLER XH.G402X.W	Y	1
9	29010009361	波纹管	ACCORDION PIPE	Y	1
10	4110000192	V型抱箍3903652	V-ANCHOR EAR 3903652	Y	2
11	4110000267	空气滤清器A669	AIR FILLTER A669	Y	1
12	4110000181	盆式粗滤器PC100-0000	FILLTER PC100-0000	Y	1
13	4011000102	螺栓GB5783-M8*16EpZn-8.8	BOLT GB5783-M8*16EpZn-8.8	N	4
14	4013000033	螺母GB6170-M8EpZn-8	NUT GB6170-M8EpZn-8	N	4
15	4015000072	垫圈GB97.1-8EpZn-300HV	WASHER GB97.1-8EpZn-300HV	N	8
16	29010009502	空滤器支架	FRAME	Y	1
17	4011000560	螺栓GB16674-M12*25EpZn-8.8	BOLT GB16674-M12*25EpZn-8.8	N	6
18	29010009721	水(油)温表接头	WATER(OIL)TEMPERATURE INDICATOR	Y	2
19	29010011881	油门操纵机构	GOVERNOR CONTROL SYSTEM	N	1
20	29010000041	螺栓	BOLT	Y	1
21	29010000061	垫圈	WASHER	Y	3
22	4011000184	螺栓GB5783-M10*40EpZn-8.8	BOLT GB5783-M10*40EpZn-8.8	N	12
23	4015000025	垫圈GB93-10-65Mn	WASHER GB93-10-65Mn	N	24
24	29010009711	双头螺栓	BOLT	Y	8

发动机总成 DIESEL ENGINE ASSEMBLY

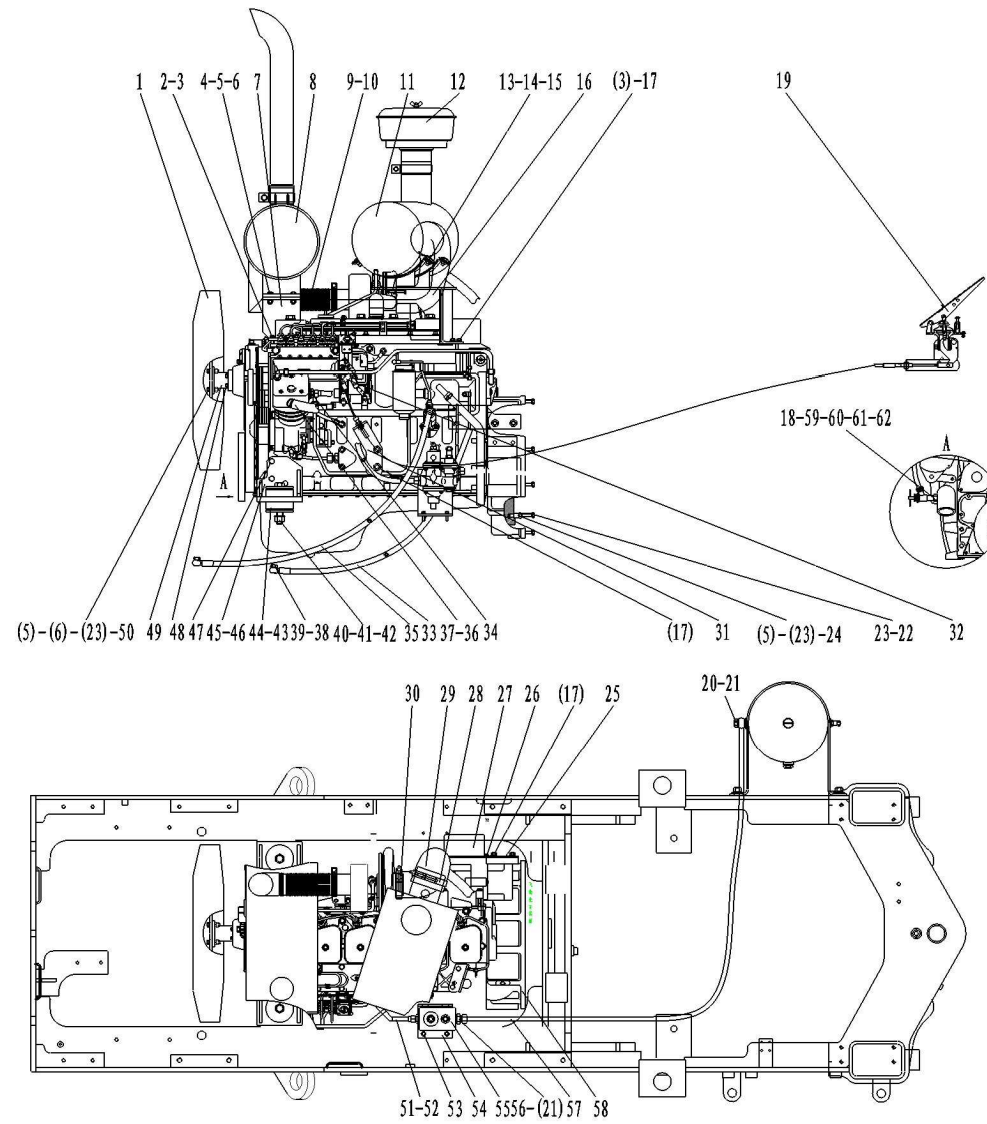

序号 Key	零件代号 Part No.	名称 Description	是否配件 Spare parts Y/N	数量 Qty	备注 Remarks
25	29010009522	继电器固定板	RELAY FIXATION PLANT	Y	1
26	4014000051	螺钉GB818-M8*16EpZn-4.8	BOLT GB818-M8*16EpZn-4.8	N	2
27	29010012261	继电器保护盒	RELAY BOX	Y	1
28	4019000017	T型抱箍φ117140312	T-ANCHOR EARφ117140312	N	1
29	29010009531	增压器进气管	SUPERCHARGER HOSE	Y	1
30	4019000038	T形抱箍φ92210432	T-ANCHOR EARφ92210432	N	1
31	29010015321	软轴固定支架	BRACKET	Y	1
32	29010015301	油门拉杆	GOVERNOR LEVER	Y	1
33	29010015311	燃油回油管	OIL-RETURN PIPE	Y	1
34	29010009571	二通接头	CONNECTOR	Y	1
35	29010009581	燃油进油管	OIL-INPUT PIPE	Y	1
36	4120001078	胶管JB8406-B25*1300	HOSE JB8406-B25*1300	Y	1
37	4017000008	喉箍JB8870-d40	CLAMP JB8870-d40	N	2
38	4011000641	螺栓JB6013-M14*1.5EpZn-45	BOLT JB6013-M14*1.5EpZn-45	N	2
39	4015000231	垫圈JB6013-14-T2	WASHER JB6013-14-T2	N	4
40	4011000236	螺栓GB5782-M20*130EpZn-8.8	BOLT GB5782-M20*130EpZn-8.8	N	2
41	4013000020	螺母GB6170-M20EpZn-8	BOLT GB6170-M20EpZn-8	N	2
42	4015000176	垫圈GB97.1-20EpZn-300HV	WASHER GB97.1-20EpZn-300HV	N	2
43	29050000101	减震块	SHOCK MOUNT	Y	4
44	29050000121	垫圈	WASHER	Y	4
45	29010011891	右支架	RIGHT BRACKET	Y	1
46	29010011901	左支架	LEFT BRACKET	Y	1
47	4011000091	螺栓GB5783-M12*40EpZn-8.8	BOLT GB5783-M12*40EpZn-8.8	N	6
48	4011000161	螺栓GB16674-M8*35EpZn-8.8	BOLT GB16674-M8*35EpZn-8.8	N	4

发动机总成 DIESEL ENGINE ASSEMBLY

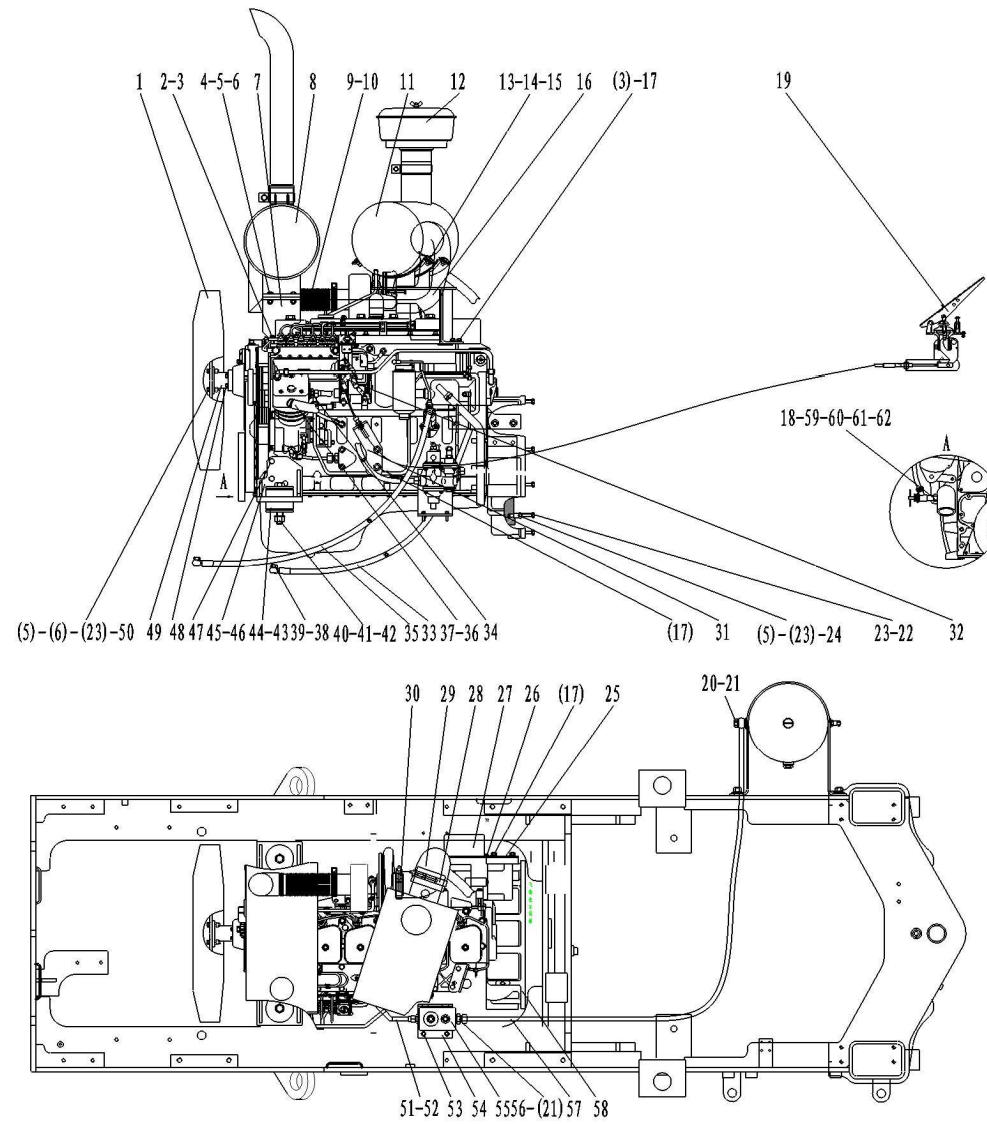

序号 Key	零件代号 Part No.	名称 Description	是否配件 Spare parts Y/N	数量 Qty	备注 Remarks
49	29010011911	风扇连接法兰	FAN CONNECT FLANGE	Y	1
50	4011000475	螺栓GB16674-M10*30EpZn-8.8	BOLT GB16674-M10*30EpZn-8.8	N	4
51	4120000750	金属软管	METAL TUBE	Y	1
52	29010000051	垫圈	WASHER	Y	3
53	4011000455	螺栓GB16674-M8*25EpZn-8.8	BOLT GB16674-M8*25EpZn-8.8	N	2
54	29220004021	油水分离器支架	BRACKET	Y	1
55	4120000084	油水分离器组合阀ST-50G	AIR DYER ST-50G	Y	1
56	29010000071	二通接头	CONNECTOR	Y	1
57	4041000560	软管LGB149-004220	TUBE LGB149004220	Y	1
58	4110000555	发动机总成6BT5.9-C130(SO11686)	DIESEL ENGINE ASSEMBLY 6BT5.9-C130(SO11686)	Y	1
59	4120000067	暖风机水阀LG12-NFJSF	VALVE LG12-NF JSF	Y	2
60	4017000024	环箍QC390-D26	CLAMP QC390-D26	N	4
61	4120000049	胶管JB8406-B16*2600	RUBBER TUBE JB8406-B16X2600	Y	1
62	4120000119	胶管JB8406-B16*2300	RUBBER TUBE JB8406-B16X2300	Y	1

燃油箱总成 FUEL TANK ASSEMBLY

