

LG936 轮式装载机 零部件图册

LG936 WHEEL LOADER PARTS CATALOG

山东临工工程机械有限公司

SHANDONG LINGONG CONSTRUCTION MACHINERY CO., LTD.

LG936 轮式装载机 零部件图册

LG936 WHEEL LOADER PARTS CATALOG

2007年12月 第3版 2007年12月 第1次印刷

2007-12 Version 3 2007-12 Printed 1

山 东 临 工 工 程 机 械 有 限 公 司

SHANDONG LINGONG CONSTRUCTION MACHINERY CO., LTD

地址：中国·临沂经济开发区临工工业园

Add: Lingong Industry Park, Linyi Economic Development Zone, Shandong, china

电话：86-0539-8785800

Tel: 86-0539-8785696

传真：86-0539-8785671

Fax: 86-0539-8785618

技术服务：800-8607999 400-6587999

Web: www.sdlg.cn

前言

LG936 轮式装载机零部件图册，是为了方便用户使用、维修和保养而绘制的，以供在使用过程中查阅及参考，也可帮助用户了解本机的结构和装配关系。发动机的零部件详见其随机资料，本图册不再绘出。

本图册按系统划分绘制出了各零部件的图形及相互装配关系。凡装机后不可拆卸的部件（如焊接件、铆合件），只标出部件代号，不另列其组成零件。本图册明细表采用中英文对照编排。

本图册主要根据标准型产品(订货号 3601114A2908)编绘，其它非标准配置，可参照执行，详情请咨询山东临工、当地经销商或登录山东临工网站查询。随着科技的进步，产品将会不断改进，故本图册的内容可能会有部分与以后的产品不一致，恕不另行通知。敬请用户在订购配件时，指明所购整车的出厂日期和编号。

编者

2007 年 12 月

FOREWORD

THIS PART LIST OF LG936 WHEEL LOADER IS MADE FOR THE CONVENIENCE OF USERS TO USE ,REPAIR AND MAINTAIN THE MACHINE, AND IT CAN BE REFERED IN THE PROCESS OF USING. IT CAN ALSO HELP THE USERS TO BE FAMILIAR WITH THE CONSTRUCTION AND ASSEMBLY RELATION OF THE MACHINE. THE PART OF THE ENGINE IS SHOWED IN DETAIL IN ITS STRUCTION HANDBOOK. SO THIS CATALOG DOES NOT CONTAIN THE ENGING PART LIST.

THE CATALOG CONTAINS THE PART DRAWINGS OF DEFERENT ASSEMBLIES, SHOWING THE SHAPE OF THE PARTS AS WELL AS THE ASSEMBLING RELATION. THE COMPONENTS WHICH CAN NOT BE TAKEN APART (SUCH AS THE WELDMENT OR RIVETED ASSEMBLIES) ARE INDICATEED ONLY BY THEIR COMPONET NUMBERS WITHOUT THE CONSISTING PART NUM-BERS .THE LIST IN THE CATALOG IS ARRANGED BY CHINESE VERSUS ENGLISH.

THIS CATALOG IS MAINLY BASED ON THE STANDARD PRODUCT (ORDER NUMBER 3601114A2908) THE OTHERS OF NONSTANDARD PRODUCT CAN REFER THE STANDARD PRODUCT, AND THE DETAILED INFORMATION CAN BE KNOWN FROM SHANDONG LINGONG, THE LOACAL DEALER OR LINGONG WEBSITE ALTERATIONS IN DESIGN ARE NECESSARILY WITH THE THECHNICAL DEVELOPMENT SO SOME CONTENT IN THE CATALOG PROBABLY IS NOT CONSISTANT WITH THE FUTURE PRODUCTS, AND THIS WILL NOT NOTICE USERS. THEREFORE WHEN ORDERING SPARE PARTS, USERS ARE KINGLY REQUSETED TO INFORM US THE MANUFACTURING DATE AND BATCH NUMBER OF THE WHEEL LOADER.

THE COMPILER

2007.12

A. 发动机系统	
A. DIESEL ENGINE SYSTEM	
发动机系统·····	A1
DIESEL ENGINE SYSTEM·····	A1
油门操纵机构·····	A2
GOVERNOR CONTROL SYSTEM·····	A2
停车操纵机构·····	A3
PARKING CONTROL SYSTEM·····	A3
B. 变矩器系统	
B. TORQUE CONVERTER SYSTEM	
变矩器系统·····	B1
TORQUE CONVERTER SYSTEM·····	B1
液力变矩器·····	B2
HYORQUE CONVERTER SYSTEM·····	B2
传动油滤清器·····	B3
HYORQUE CONVERTER SYSTEM·····	B3
C. 变速箱系统	
C. TRANSMISSION SYSTEM	
变速箱总成（I）·····	C1
TRANSMISSION ASSEMBLY（I）·····	C1
变速箱总成（II）·····	C2
TRANSMISSION ASSEMBLY（II）·····	C2
三轴总成·····	C3
3RD SHAFT·····	C3
四轴总成（I）·····	C4
4RD SHAFT（I）·····	C4
超越离合器总成·····	C5
OVERRUNNING CLUTCHES·····	C5
四轴总成（II）·····	C6
4RD SHAFT（II）·····	C6
输出轴总成·····	C7
OUTPUT SHAFT·····	C7
D. 变速操纵系统	
D. TRANSMISSION SYSTEM	
变速操纵系统·····	D1
TRANSMISSION SYSTEM·····	D1
E. 驱动桥系统	
E. AXLE SYSTEM	
驱动桥系统·····	E1
AXLE SYSTEM·····	E1
驱动桥总成·····	E2
AXLE ASSEMBLY·····	E2
前主传动总成·····	E3
FRONT AXLE MAINDRIVE ASS'Y·····	E3
后主传动总成·····	E4

目录 CONTENTS

REAR AXLE MAINDRIVE ASS'Y	E4
轮边减速器总成	E5
FINAL DRIVE ASSEMBLY	E5
F. 工作装置液压系统	
F. IMPLEMENT HYDRAULIC SYSTEM	
液压操纵总成	F1
HYDRAULIC CONTROL ASSEMBLY	F1
工作齿轮泵总成	F2
WORKING GEAR PUMP	F2
转斗油缸总成	F3
DUMP CYLINDER ASSEMBLY	F3
动臂油缸总成	F4
LIFT ARM CYLINDER ASSEMBLY	F4
多路阀	F5
MULTIPLDIRECTIONALCONTROLVALVE	F5
转斗油缸(371401)	F6
DUMP CYLINDER(371401)	F6
转斗油缸(371368)	F7
DUMP CYLINDER(371368)	F7
动臂油缸(371401)	F8
LIFT ARM CYLINDER(371401)	F8
动臂油缸(371368)	F9
LIFT ARM CYLINDER(371368)	F9
G. 油箱	
G. TANK	
燃油箱总成	G1
FUEL TANK ASSEMBLY	G1
液压油箱总成	G2
HYDRAULIC TANK ASSEMBLY	G2
H. 工作装置	
H. WORKING EQUIPMENT	
工作装置	H1
WORKING EQUIPMENT	H1
I. 转向系统	
I. STEERING SYSTEM	
转向系统	I1
STEERING SYSTEM	I1
转向油缸	I2
STEERING CYLINDER	I2
优先阀	I3
PRIORITY VALVE	I3
J. 制动系统	
J. BRAKE SYSTEM	
行车制动系统	J1
SERVICE BRAKE SYSTEM	J1

目录 CONTENTS

盘式制动器	J2
DISC BRAKE	J2
储气罐、制动阀、油水分离器	J3
AIR RESERVOIR、BRAKE CONTROL VALVE、AIR DRYER	J3
加力泵	J4
BRAKE BOOSTER	J4
气制动阀	J5
BRAKE VALVE	J5
驻车制动系统	J6
PARKING BRAKE SYSTEM	J6
手制动器	J7
HAND BRAKE	J7
K. 车架	
K. FRAME	
前车架总成	K1
FRONT FRAME	K1
后车架总成	K2
REAR FRAME	K2
配重铁总成	K3
COUNTER WEIGHT	K3
L. 驾驶室	
L. CAB GROUP	
驾驶室总成	L1
CAB GROUP	L1
驾驶室内饰	L2
CAB INTERIOR DECORATION	L2
座椅支架总成	L3
SEAT ASSEMBLY	L3
M. 覆盖件系统	
M. COVER SYSTEM	
发动机罩总成	M1
HOOD OF DIESEL ENGINE ASSEMBLY	M1
左台架总成	M2
LEFT BENCH GROUP	M2
右台架总成	M3
RIGHT BENCH GROUP	M3
左、右灯架	M4
LEFT RIGHT LAMP FRAME	M4
左、右前挡泥瓦	M5
LEFT RIGHT FRANT RENDER	M5
电瓶箱总成	M6
BATTERY CASE ASSEMBLY	M6
下梯总成	M7
DOWN LODDER ASSEMBLY	M7
N. 空调系统	

目录 CONTENTS

N. AIR CONDITIONER SYSTEM

空调系统.....	N1
AIR CONDITIONER SYSTEM	N1
暖风机.....	N2
WARMING MACHINE.....	N2

0. 电气系统

0. ELECTRIC SYSTEM

电气系统.....	01
ELECTRIC SYSTEM.....	01
双音盆形喇叭总成.....	02
SACKBUT ASSEMBLY.....	02

A 发动机系统
DIESEL ENGINE SYSTEM

山东临工工程机械有限公司
SHANDONG LINGONG CONSTRUCTION MACHINERY CO. , LTD.

A1

发动机系统

DIESEL ENGINE SYSTEM

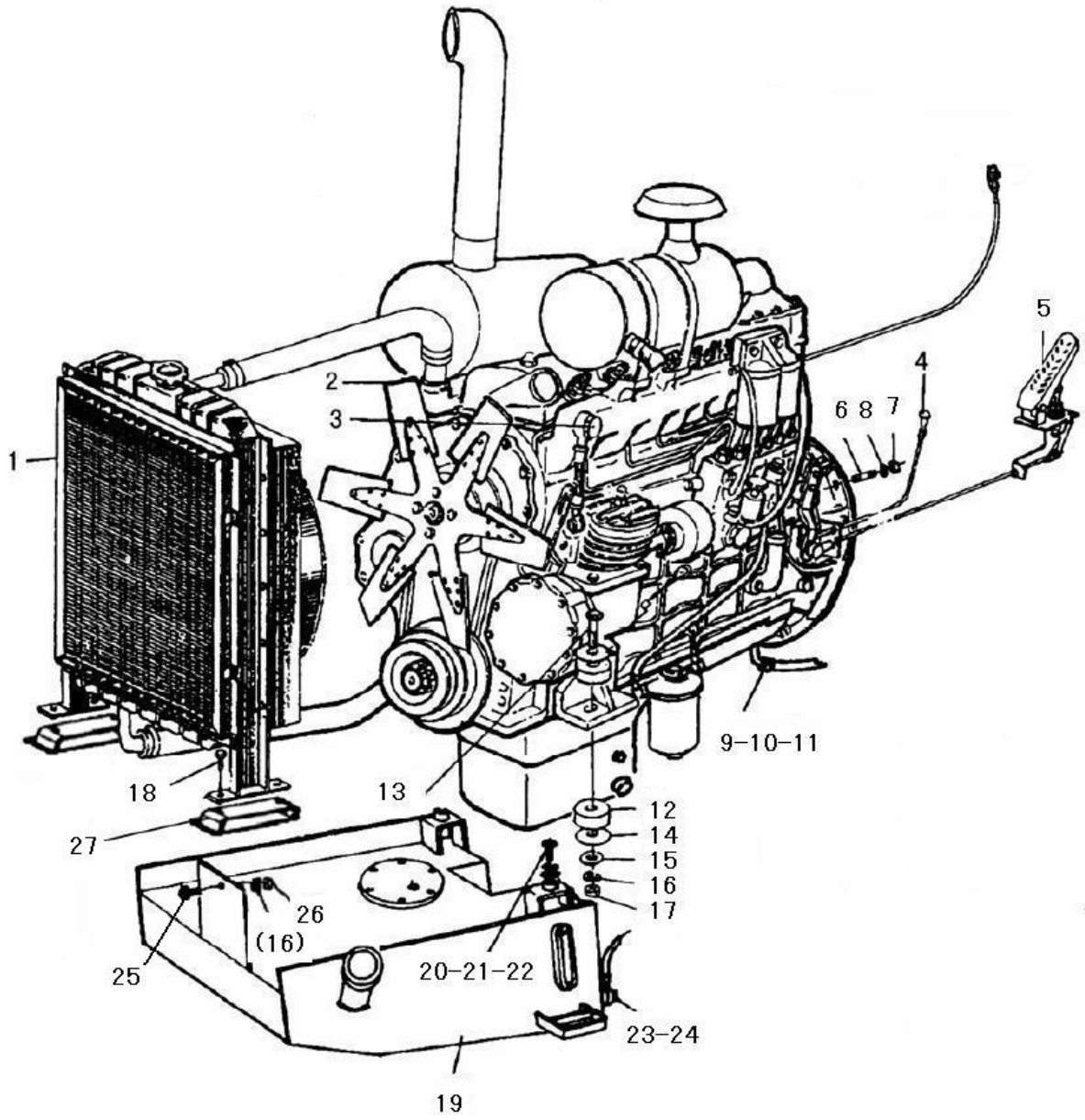

A1

序号	代号	名称		数量	备注
KEY	PART NO.	DESCRIPTION		QTY	REMARKS
1	4120000353	散热器总成 LY-930	RADIATOR ASS'Y LY-930	1	
2	2010900109	发动机总成 YC6108G(B7626)	DISEL ENGINE ASS'Y YC6108G(B7626)	1	
3	3010900168	水(油)温表接头	THERMOMETER JOINT	1	
4	2010900303	停车操纵机构	PARKING CONTROL SYSTEM	1	
5	2010900005	油门操纵机构	GOVERNOR CONTROL SYSTEM	1	
6	3010900051	双头螺柱	DOUBLE SCREW BOLT	12	
7	4013000007	螺母 GB6170-M10EpZn-8	NUT GB6170-M12EpZn-8	12	
8	4015000025	垫圈 GB93-10-65Mn	WASHER GB93-12-65Mn	12	
9	29010008691	回油接头	FITTING OIL RETURN	1	
10	29010008701	输油胶管	TUBE PIPE	1	
11	4120000075	胶管夹箍 Q/ZB251-1/2"	CLAMP Q/ZB251-1/2"	2	
12	2010900047	减震块	SHOCK MOUNT	4	
13	4011000236	螺栓 GB5782-M20*130EpZn-8.8	BOLT GB5782-M20*130EpZn-8.8	2	
14	3010900094	垫圈	WASHER	4	
15	4015000176	垫圈 GB97.1-20EpZn-300HV	WASHER GB97.1-20EpZn-300HV	2	
16	4015000030	垫圈 GB93-20-65Mn	WASHER GB93-20-65Mn	2	
17	4013000020	螺母 GB6170-M20EpZn-8	NUT GB6170-M20EpZn-8	2	
18	4011000320	螺栓 GB16674-M12*40EpZn-8.8	BOLT GB16674-M12*40EpZn-8.8	4	
19	2010900008	燃油箱总成	FUEL TANK	1	
20	4011000117	螺栓 GB5785-M24*2*150-8.8	BOLT GB5785-M24*2*150-8.8	2	
21	4015000167	垫圈 GB97.1-24EpZn-300HV	WASHER GB97.1-24EpZn-300HV	2	
22	4015000031	垫圈 GB93-24-65Mn	WASHER GB93-24-65Mn	2	
23	3010900007	垫圈	WASHER	4	
24	3010900003	接头螺钉	BOLT	2	
25	4011000114	螺栓 GB5785-M20*2*60EpZn-8.8	BOLT GB5785-M20*2*60EpZn-8.8	1	
26	4013000040	螺母 GB6171-M20*2EpZn-8	NUT GB6171-M20*2EpZn-8	1	
27	29010013361	支架	FRAME	2	