

LIEBHERR

Mobile crane with telescopic boom

LTM 1400-7.1

LTM 1400-7-1-007

Operating instructions

BAL-No.: 14626-01-02

Pages: 1475

Works-Number	
Date	

ORIGINAL OPERATING MANUAL

The operating manual is part of the crane!

It must always be available within reach!

The traffic regulations and those for crane operation must be observed!

Liebherr-Werk Ehingen GmbH

Postfach 1361

D-89582 Ehingen / Donau

☎: +49 (0) 7391 502-0

Fax: +49 (0) 7391 502-3399

✉: info.lwe@liebherr.com

www.liebherr.com

Foreword

General

This crane was built according to the state of technology and recognized safety technical regulations. Despite that, dangers to body and life for the user and / or third persons or damage to the crane and / or other material assets can occur.

This crane may only be used:

- in impeccable technical condition.
- for destined use.
- by trained personnel, which acts in a safety and danger conscious way.
- when no safety relevant problems are present.
- when no modifications were made on the crane.

Any problems, which could affect safety must be fixed immediately.

Modifications on the crane may only be made with written approval by Liebherr-Werk Ehingen GmbH.

Data recording device

This crane is equipped with a data recording device. Among others, the following data is recorded:



- Date and time of day
- Entered configuration of the crane
- Actual load
- Percentage of utilization of the crane
- Working radius
- Main boom angle, luffing jib angle
- Total telescopic boom length, length of each telescopic section
- Every actuation of bypass devices

The recorded data can be read with a respective software.

Safety and warning notes

Safety and warning notes are directed to all persons who work with the crane.

The terms **DANGER**, **WARNING**, **CAUTION** and **ATTENTION** used in the crane documentation are intended to point out certain rules of conduct to all persons working with the crane.

Warn- ing signs	Signal word	Explanation
	DANGER	Designates a dangerous situation which will lead to death or serious injury if it is not prevented ¹⁾ .
	WARNING	Designates a dangerous situation which could lead to death or serious injury if it is not prevented ¹⁾ .
	CAUTION	Designates a dangerous situation which could lead to slight or medium injury if it is not prevented ¹⁾ .
	CAUTION	Designates a dangerous situation, which can lead to property damage if it is not prevented.

1) This could also result in property damage.

Additional notes

The term **Note** is used in these operating instructions to indicate useful information and tips to all persons working with the crane.

Sign	Signal word	Explanation
	Note	Designates useful information and tips.

Crane documentation

The crane documentation is comprised of:

- all supplied documents on paper and in digital form.
- all supplied programs and applications.
- all subsequently supplied information, updates and addenda for the crane documentation.

The crane documentation:

- makes it possible for you to operate the crane safely.
- supports you to utilize the permissible application possibilities of the crane.
- provides you with information about the functionality of important components and systems.



Note

Terminology in the crane documentation.

Certain expressions are used in the crane documentation.

- ▶ In order to avoid misunderstandings, the same expressions should always be used.

Translations from the German version of the crane documentation: The crane documentation has been translated to be best of one's knowledge. Liebherr-Werk Ebingen GmbH assumes no liability for translation errors. The German version of the crane documentation is solely applicable for factual accuracy. If you find any errors or if any misunderstandings arise when reading the crane documentation, please contact Liebherr-Werk Ebingen GmbH immediately.

**WARNING**

Danger of accident due to incorrect operation of the crane!

Incorrect operation of the crane can lead to accidents!

Personnel can be killed or seriously injured!

This could result in property damage!

- ▶ Only authorized and trained expert personnel are permitted to work on the crane.
- ▶ The crane documentation is part of the crane and must be accessible on the crane.
- ▶ The crane documentation and on-site regulations and specifications (such as accident prevention regulations) must be observed.

Using the crane documentation:

- **makes it easier** to become familiar with the crane.
- **avoids** problems due to improper operation.

Observing the crane documentation:

- **increases** reliability in use.
- **extends** the service life of the crane.
- **minimizes** repair costs and downtime.

Place the crane documentation accessible in the driver's cab or in the crane cab.

**WARNING**

Outdated version of crane documentation!

If subsequently supplied information, updates and addenda to the crane documentation are not observed and added, there is a danger of accidents!

Personnel can be killed or seriously injured!

This could result in property damage!

- ▶ Observe and add all subsequently supplied information, updates and addenda for the crane documentation.
- ▶ Make sure that all affected persons always know and understand the latest version of the crane documentation.

**WARNING**

Crane documentation is not understood!

If parts of the crane documentation are not understood and the tasks are carried out on or with the crane, then there is a danger of accidents!

Personnel can be killed or seriously injured!

This could result in property damage!

- ▶ In case of questions regarding the crane documentation, before carrying out the respective task, contact Liebherr Service.

This documentation may not be reproduced or duplicated, distributed or used for purposes of competition, neither in part nor in excerpts. All rights are expressly reserved in accordance with copyright laws.

All accident prevention guidelines, operating instructions, etc. are based on destined use of the crane.

blank page!

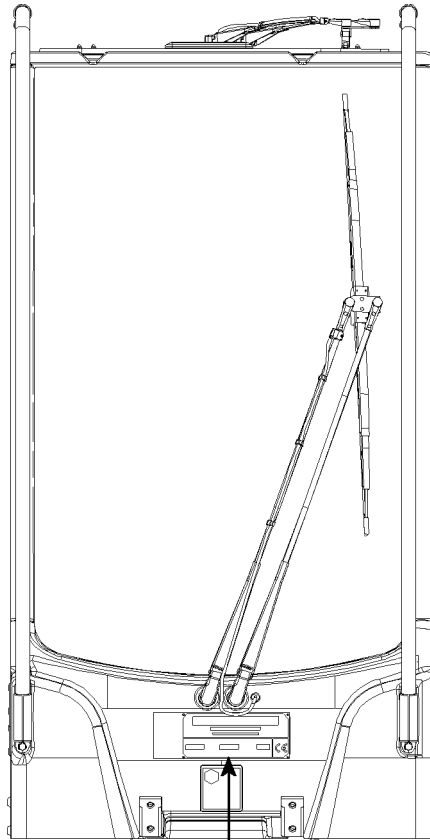

1

LIEBHERR		
WERK EHINGEN GMBH D-89582 EHINGEN/DONAU		
Type	n° d'usine	année de construction
	Werk-Nr.	Baujahr
Type	Works No.	Year of manufacture
Manufactured in Germany		



2

LIEBHERR		
WERK EHINGEN GMBH D-89582 EHINGEN/DONAU		
Type	n° d'usine	année de construction
	Werk-Nr.	Baujahr
Type	Works No.	Year of manufacture
Manufactured in Germany		

CE marking

The CE marking is a mark according to EU laws:

- Cranes with CE-marking according to the European machinery directive 2006/42/EC and the EN 13000! Data tag Crane with CE-marking, see illustration 1.
- Cranes which are operated outside the respective area of application do not require a CE marking. Data tag Crane without CE marking, see illustration 2.
- It is prohibited to market and operate cranes without CE marking, which do not meet the product-specific regulations valid in Europe, when a CE marking is specified for the country.
- It is prohibited to operate cranes with a tipping load utilization of 85 % which are programmed according to ASME B30.5 within the European Union or in countries which permit a lower stationary stability utilization (for example ISO 4305)! The national regulations apply. These cranes may not have a CE marking!

Destined use

The destined use of the crane consists solely in vertical lifting and lowering of free and non-adhered loads, whose weight and center of gravity are known.

To do so, a hook or hook block approved by Liebherr must be reeved on the hoist rope and it may only be operated within the permissible crane configurations.

Driving with the crane, with or without an attached load is only permissible if a corresponding driving or load chart is available. The set up configurations intended for it and the safety conditions must be observed according to the corresponding crane documentation.

Any other use or any other exceeding utilization is **not** destined use.

Destined use also includes the adherence of the required safety guidelines, conditions, prerequisites, set up conditions and working steps in the crane documentation (for example: Operating instructions, load charts, erection and take down charts, job planner).

The manufacturer is **not** liable for damages, which are caused by non-destined use or improper use of the crane. Any associated risk it is carried solely by the owner, the operator and the user of the crane.

Non-destined use

Non -destined use is:

- Working outside the permissible set up configurations according to the load chart.
- Working outside the permissible boom radii and slewing ranges according to the load chart.
- Selecting load values, which do not correspond to the actual set up configuration.
- Selection of a set up configuration via code or via manual entry, which does not correspond to the actual set up configuration.
- Working with bypassed / deactivated safety devices, for example bypassed load moment limitation or with bypassed hoist limit switch.
- Increasing the radius of the lifted load after a LMB shut off, for example by diagonally pulling the load.
- Using the support pressure display as a safety function against tipping over.
- Use of equipment parts which are not approved for the crane.
- Using the crane at sports and recreational events, especially for "Bungee" jumps and / or "Dinner in the sky".
- Driving on a public road in non-permissible driving condition (axle load, dimension).
- Driving with the equipment in place in a non-permissible driving condition.
- Pushing, pulling or lifting loads with the leveling regulation, the sliding beams or the support cylinders.
- Pushing, pulling or lifting loads by actuating the slewing gear, the luffing gear or the telescoping gear.
- Ripping stuck objects loose with the crane.
- Utilizing the crane for a longer period of time for material handling tasks.
- Releasing the crane suddenly (grapple or dumping operation).
- Utilizing the crane when the weight of the load, which is suspended on the crane is changed, for example by filling a container suspended on the load hook, except:
 - The load moment limiter was checked before for function with a known load.
 - The crane cab is occupied.
 - The crane is operational.
 - The container size is selected in such a way that an overload of the crane with full load is eliminated within the valid used load chart.

The crane may **not** be used for:

- Attaching a stuck load for which the weight and center of gravity are not known and which is released first, for example with a cutting torch.
- Letting persons drive along outside the driver's cab.
- Transporting personnel in the crane cab while driving.
- Transporting personnel with the lifting equipment and on the load.
- Transporting of persons with work baskets (cherry pickers), if the national regulations of the responsible work safety organization are not observed.
- Transporting loads on the chassis.
- Two hook operation without auxiliary equipment.
- Extended material handling operation.
- Crane operation on a barge if the conditions are not determined and the written release by **Liebherr Werk Ehingen GmbH** is not present.

The crane documentation must be read and used by all persons who are involved in use, operation, assembly and maintenance of the crane.

Safety equipment

Special attention must be paid to the safety equipment built into the crane. The safety equipment must constantly be checked for functionality. The crane may not be operated if the safety equipment is not working or not working correctly.

**Note**

Your motto must always be:

- ▶ **Safety first!**

The crane has been built in accordance with the applicable crane operation and driving regulations and has been approved by the relevant authorities.

Equipment and spare parts**WARNING**

Danger to life if original equipment parts are **not** used!

If the crane is operated with equipment parts, which are **not** original, then the crane can fail and cause fatal accidents!

Crane components can be damaged!

- ▶ Operate the crane only with original equipment parts!
- ▶ Crane operation with equipment parts, which do **not** belong to the crane is prohibited!
- ▶ If there is any doubt about the origin of equipment parts, contact Liebherr Service!

**WARNING**

The crane permit and the manufacturer's warranty will become void!

If any original installed parts are modified, manipulated or replaced (e.g. removal of parts, installation of non-original Liebherr parts), both the crane permit and the manufacturer's warranty will become void.

- ▶ Leave installed original parts unchanged!
- ▶ Do not remove installed original parts!
- ▶ Use only original Liebherr spare parts!
- ▶ If there is any doubt about the origin of spare parts, contact Liebherr Service!

For ordering equipment and spare parts, always keep the crane number handy and provide it.

Definition of directional data for mobile cranes

Driving forwards: Driving with the driver's cab on the front.

Driving in reverse: Driving with the taillights of the crane chassis on the front.

Front, rear, right, left in the **driver's cab** refer to the crane chassis. The driver's cab is always in the front.

Front, rear, right, left in the **crane operator's cab** refer to the superstructure. Front is always in direction of the placed down boom.

Definition of directional data for crawler cranes

Driving forwards: Driving forward from the view of the crane operator seated in the crane cab. Turntable in 0° or 180° position.

Driving in reverse: Driving backward from the view of the crane operator seated in the crane cab. Turntable in 0° or 180° position.

Front, rear, right, left always orient themselves on the **crawler track** from the position of the chain tension devices. The chain tension devices on the crawler track are always on the front.

Front, rear, right, left refer to the direction of view of the crane operator seated in the **crane cab**. Front is always in direction of the placed down boom.

Optional equipment and functions

The equipment marked with * and the functions are optionally available and are **not** part of the standard crane (optional equipment).

Contents

1.00 Description of crane	23
1.01 Terminology	24
1 Short designation of boom systems	25
2 Component overview	31
1.02 Product description	38
1 Crane chassis	39
2 Crane superstructure	40
3 Additional equipment	41
1.03 Technical data	42
1 Dimensions	43
2 Tires	43
3 Weights	44
4 Workplace-related emission value	44
5 Vibrations	44
6 Speeds	45
7 Rope diameter	46
8 Hoisting heights	46
2.00 Safety	55
2.01 Traffic regulations	56
1 Traffic regulations	57
2.02 Break-in instructions	58
1 Break-in instructions	59
2.03 Job planning	60
1 Planning crane operation	61
2.04 General safety technical guidelines	62
1 General	63
2 Emergency exit	69
3 Checking the rigging and fastening points	73
4 Personal protective equipment	75

5	Use of single-stranded height safety equipment, illustration 1	81
6	Use of double-stranded height safety equipment, illustration 2	81
7	Securing the assembly personnel against falling	81
8	Rescuing the assembly personnel	83
9	Documentation	83
10	Identification	83
11	Requirements for the crane operator	83
12	Selecting the location, illustrations 1 to 3	89
13	Slopes and excavations, illustrations 4 and 5	92
14	Permissible ground pressures	92
15	Supporting	97
16	Checking the safety measures	98
17	Endangering air traffic	98
18	Grounding	99
19	Consideration of wind conditions	99
20	Working in the vicinity of transmitters	107
21	Dangers when working together with several cranes	109
22	Hand signals for guidance	110
23	Crane operation with a load	117
24	Lifting of personnel	120
25	Crane operation in case of thunderstorms	121
26	Safety instructions for external power supply (230 V AC)	122
27	Welding work on the load	122
28	Interruption of crane operation.	123
29	Resumption of crane operation.	124
30	Ending crane operation	124
31	Turning / driving in reverse	125
32	Parking the vehicle	125
33	Safety guidelines for ladders	129
2.05	Signs on the crane	135
1	Warning signs	137
2	Command and prohibition signs	141
3	Notice signs	145
2.06	Antifall guards on the crane	150

1	Personal protective equipment	151
2	Attachment and fastening points	153
3	Railing	155
4	Fall protection equipment: Retaining ropes	157
2.10	General safety technical notes for driving with dolly	160
1	Travel operation with dolly	161
3.00	Crane chassis operation	171
3.01	Operating and monitoring instruments on the crane chassis	172
1	Operating and control instruments - Vehicle	173
3.02	Before starting to travel	194
1	General checks before starting to drive	195
2	Work station - Driver's cab	203
3.03	Axle suspension system	210
1	Axle suspension / axle locking system	211
2	Axle suspension system	213
3	Axle locking system	219
3.04	Travel operation	220
1	Crane driving conditions	221
2	Starting and stopping the engine	223
3	Driving	231
4	Differential locks	269
5	Steering	275
6	Towing	285
3.05	Crane support	286
1	General	287
2	Outrigger control unit	293
3	Before leaving the work site	305
3.80	Transport of crane and crane components	306
1	Transporting the TY-guying	307
4.00	Operation of crane superstructure	311
4.01	Operating and monitoring instruments on the crane superstructure	312
1	Operating and control instruments	313
4.02	LICCON computer system	328

1	General	329
2	LICCON computer system boot up	331
3	Operating elements of the LICCON computer system	335
4	“Set up” program	337
5	The “Operation” program	355
6	“Telescoping” program	409
7	“Control parameter” program	413
8	The “Working range limitation” program*	421
9	The “Support” program	423
10	The “Engine monitoring” program	435
11	“Tele guying* ” program	443
12	LICCON computer system in stand-by mode	449
4.03	Crane start up and taking the crane out of service	450
1	Checks before start up	451
2	Work station - Crane operator's cab	455
3	Starting and stopping the superstructure engine	463
4	LICCON computer system after engine start	471
4.04	Safety equipment	474
1	General	475
2	Quick test Crane geometry	475
3	Quick test Overload protection	475
4	LICCON computer system	475
5	Safety devices on the crane	481
4.05	Crane operation	493
1	General	495
2	LICCON computer system	501
3	Luffing	503
4	Lifting / lowering	505
5	Turning	509
6	Telescoping	515
4.06	Rope reeving	528
1	Wire ropes and rope end connections	529
2	Reeving in the hoist rope with the assembly winch*	531
3	Reeving the hook block in and out	535

4	Securing and removing the load hook*	541
5	Attaching / removing the hoist limit switch weight	545
6	Assembling / disassembling the wedge lock	549
7	Crane operation with auxiliary block* on the telescopic boom	551
8	Rope reeving	551
4.07	Counterweight	552
1	General	553
2	Assembly	561
3	Telescoping	573
4	Disassembly	575
4.08	Working with a load	582
1	Technical safety instructions for working with a load	583
2	Checks before starting to work with the crane	584
3	Crane movement - Telescoping	585
4	Taking on a load	587
5	Crane operation	591
4.12	Two hook operation	593
1	General	595
4.15	Reeving plans	600
1	General	601
2	Reeving plans	603
4.20	Procedure for shut off of crane movements	630
1	General	631
2	Instructions for resuming crane movements for cranes with CE mark	635
3	Instructions for resuming crane movements for cranes without CE mark	671
5.00	Equipment	707
5.01	Safety technical guidelines for assembly and disassembly	708
1	Checking the retaining elements	709
2	Rope pulleys	709
3	Checking the ropes	709
4	Control measures	710
5	Dangerous conditions without shut off	712
6	Transporting components	712

7	Pneumatic springs for assembly support of components	713
8	Manual rope winches for assembly support of components	713
9	Weights	714
10	Guy rods	714
11	Exceeding the overload protection	717
12	Assembly / disassembly	719
13	Erection / take down	748
5.03	Fixed lattice jib - TF	750
1	General	751
2	Assembly	761
3	Reeving in the hoist rope	769
4	Angle assembly of lattice jib	771
5	Electrical connections	773
6	Erecting the boom	775
7	Crane operation - TF	775
8	Taking the boom down	777
9	Changing the lattice jib from 20°/40° to 0°	779
10	Unreeving the hoist rope	781
11	Disassembly	783
5.04	Luffing lattice jib -TN	790
1	General	791
2	Components of luffing lattice jib	793
3	Assembly	799
4	Assembling the lattice jib	807
5	Erection	819
6	Crane operation	829
7	Take down	831
8	Disassembly	839
5.05	Telescopic boom, guyed - TY	848
1	General	849
2	Assembly	853
3	Crane operation	877
4	Disassembly	879
5.06	Luffing lattice jib, guyed	894

1	General	895
2	Assembly	897
3	Crane operation	905
4	Disassembly	907
5.07	Fixed lattice jib, guyed	914
1	General	915
2	Assembly	917
3	Crane operation	921
4	Disassembly	923
5.10	Boom nose - telescopic boom	926
1	Boom nose telescopic boom	927
5.11	Winch 3	940
1	General	941
2	Assembling winch3* with adjusting cylinder	941
3	Changing the adjusting cylinder position	955
4	Dismantling winch3*	961
5.14	Telescopic boom disassembly/assembly, luffing cylinder on the crane superstructure	962
1	General	963
2	Assembling / disassembling the straps	963
3	Disassembly of telescopic boom	965
4	Assembling the telescopic boom	971
5	Retracting the luffing cylinder with removed telescopic boom	977
5.15	Telescopic boom disassembly/assembly, luffing cylinder on the telescopic boom	978
1	Telescopic boom disassembly/assembly*	979
2	Disassembly	983
3	Assembly	991
5.17	Sliding beam disassembly/assembly	996
1	General	997
2	Remove sliding beams with auxiliary crane	999
3	Removing the sliding beams with own crane*	1001
4	Installing the sliding beams with the auxiliary crane	1007
5	Installing the sliding beams with own crane*	1009
5.18	Sliding beam box disassembly/assembly	1012

1	Sliding beam box disassembly/assembly*	1013
2	Disassembling the sliding beam box	1015
3	Turning crane superstructure (360°) without rear support	1021
4	Assembling the sliding beam box	1025
5.19	Hook blocks	1032
1	Minimum required hook block weight	1033
2	Procedure in case of slack rope	1036
3	Hook block overview	1039
4	Installing a double hook block for single operation	1041
5	Installing a double hook block for parallel operation	1051
6	Single hook blocks	1063
5.21	Boom nose N head piece	1070
1	Boom nose - N-headpiece	1071
5.27	Erection and take-down charts	1078
1	General	1079
2	Set-up and take-down chart for T operation	1079
3	Set-up and take-down chart for TY operation	1081
4	Set-up and take-down chart for TF operation	1083
5	Set-up and take-down chart for TYSF operation	1084
6	Set-up and take-down chart for TN operation	1085
7	Set-up and take-down chart for TYSN operation	1086
6.00	Additional equipment	1089
6.01	Heater / engine pre-heating	1090
1	Heating the driver's cab	1091
2	Heating the crane operator's cab	1111
6.04	Sliding beam monitoring	1124
1	General	1125
2	Support base	1125
3	Working with sliding beam monitoring	1127
4	Bypassing the sliding beam length monitoring	1131
6.05	Emergency take-down	1132
1	Emergency operation	1133

7.00 Service and maintenance	1137
7.01 Maintenance and service - General	1138
1 Liebherr Service	1139
2 General specifications	1139
3 Cleaning and care of the crane	1140
4 Measures for work interruption or transport	1141
5 Maintenance work on the crane superstructure or boom	1141
6 Maintenance and inspection guidelines	1142
7.02 Maintenance intervals - Crane chassis	1146
1 Crane chassis maintenance and inspection schedule	1147
7.03 Maintenance intervals - Crane superstructure	1155
1 Crane superstructure maintenance and inspection schedule	1157
7.04 Maintenance guidelines - Crane chassis	1165
1 Diesel engine	1167
2 Automatic transmission with torque converter coupling	1173
3 Distributor gear	1181
4 Hydraulic system	1185
5 Air dryer compressed air and brake system, illustration 5	1195
6 Tires / wheels	1195
7 Axles	1197
8 Wheel alignment	1199
9 Tilting the driver's cab	1201
10 Electrical system - Lighting	1201
7.05 Maintenance guidelines - Crane superstructure	1204
1 Crane engine	1205
2 Pump distributor gear	1213
3 Hydraulic system	1215
4 Central lubrication system	1221
5 Slewing ring connection	1229
6 Winch 1, 2 and 3, illustration 6	1231
7 Assembly winch, illustration 7	1233
8 Replacing the hoist rope / control cable	1235
9 Guy winches	1237
10 Slewing gear	1239

11 Air dryer for Compressed air and brake system	1241
12 Electrical system - Lighting	1241
13 Telescopic boom	1243
14 TY-guying	1247
7.06 Fill quantities, lubrication chart	1248
1 Fill quantities	1249
2 Lubrication schedule	1255
7.07 Service fluids and lubricants	1262
1 Specified service items and lubricants for Liebherr cranes	1263
7.15 Procedure in case of problems	1271
1 Procedure to follow in case of a problem	1273
2 Carry out error diagnostics	1279
3 Measures in clear problem cases	1285
4 Measures for defective components	1294
8.00 Inspections of cranes	1305
8.01 Periodic crane inspections	1306
1 General	1307
2 Inspection of carrying crane structures, especially steel structures	1308
3 Inspection of tires and disk wheels	1375
4 Inspecting the hoist and luffing winches	1377
5 Inspecting load hooks	1389
6 Inspecting the rope feed mechanics in the telescopic boom	1389
7 Inspection of locking system of telescopic boom	1391
8 Inspection of retaining ropes and anchor points	1393
9 Inspection of membrane accumulator	1395
10 Inspection of relapse cylinders	1396
11 Inspection of the safety controls on the relapse cylinders	1396
12 Inspecting the cable pulleys	1396
13 Inspecting the function of the overload protection	1397
14 Inspecting the roller slewing ring connection	1397
15 Inspecting the mounting of the load bearing equipment	1397
16 Inspection of the tele extension with eccentric, illustration 1	1399
17 Inspection of change over pulleys, illustration 2	1399
