

Introduction to Engine Control Systems

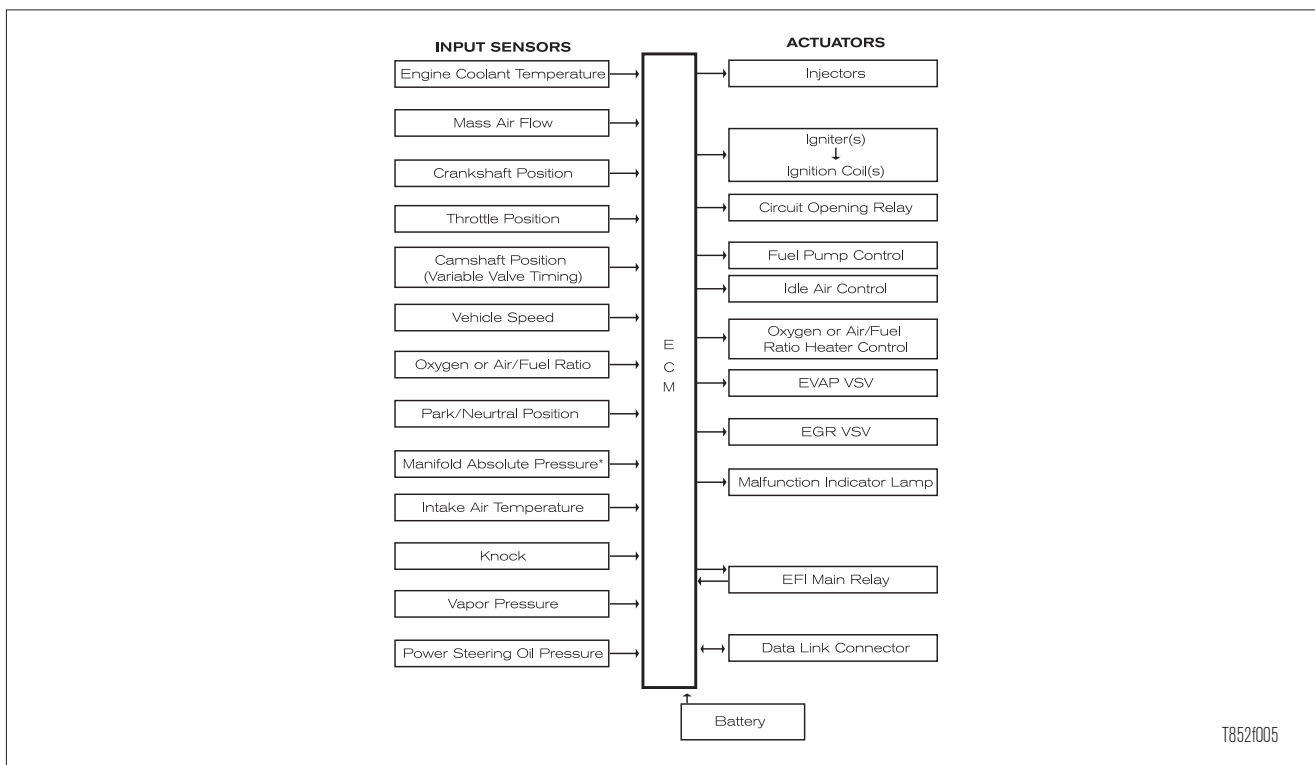

- Lesson Objectives**
1. Identify major control systems/components
 2. Locate needed engine control systems service information
 3. Familiar with engine control systems terms



Notes

A large grid area for taking notes, consisting of a 30x30 grid of small squares.

Introduction to Engine Control Systems

Basic Engine Operation

The need to achieve high power output, high fuel economy, and the lowest amount of emission gases from today's engines has led to very sophisticated engine control systems. A computer, referred to as an Engine Control Module (ECM), manages a variety of engine systems. These systems are basically divided into the following areas:

- Air induction systems.
- Fuel system.
- Ignition system.
- Exhaust/Emission control system.

All the above and other systems are controlled or sensed by the ECM. The ECM with its sensors and actuators is often referred to as the electronic control system. It is important to keep in mind while diagnosing engine concerns that the fundamentals of engine operation (correct mixture of air and fuel sufficiently compressed and ignited at the proper time) are not different. The following is an overview of these systems.

Basic Air Induction System

The amount of air is measured and the air is controlled for efficient engine operation. The idle air control valve is not used on electronic throttle controlled systems.

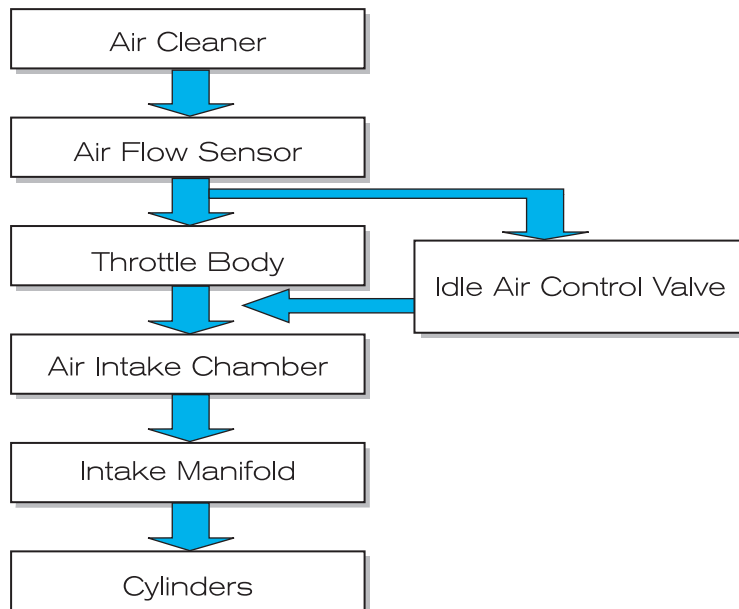

Fig. 1-01

L852f001

Air Induction System

Air filtered by the air cleaner is measured by the air flow sensor (commonly called the mass air flow sensor). The volume of air is regulated by the throttle valve. The idle air control valve regulates the amount of air bypassing the throttle valve to adjust idle speed. The air intake chamber and intake manifold are tuned for efficient engine operation.

There are many variations on the basic air induction system. The Acoustic Controlled Induction System (ACIS) modifies air intake runner length for greater efficiency. Variable valve timing changes valve overlap for better engine efficiency.

Basic Fuel Injection System

Based on signals received, the ECM calculates how long and when to turn on the injectors to deliver the correct amount of fuel.

*The location of the pressure regulator varies with system. When excess fuel is returned to the fuel tank (return type) the pressure regulator is after the injectors. On the returnless fuel system, the pressure regulator is in the fuel tank.

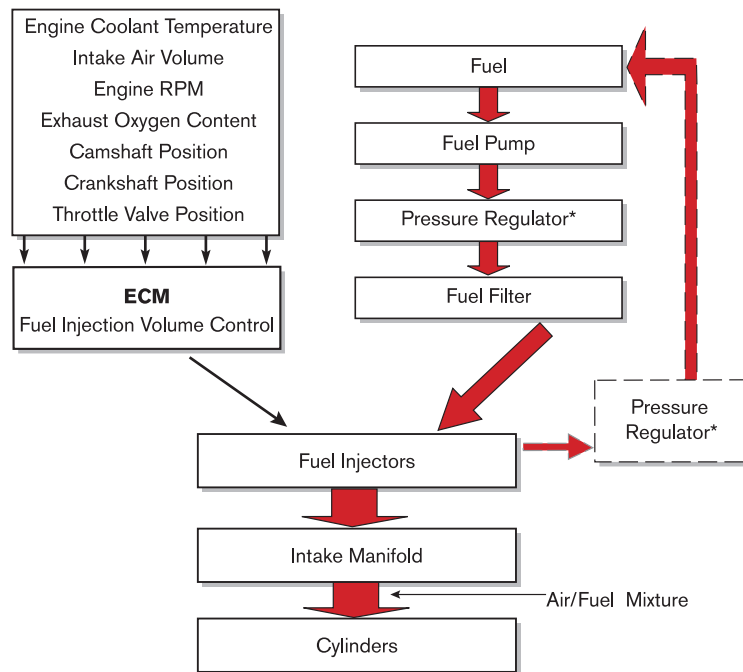

Fig. 1-02
T8521002

Fuel System

The fuel system needs to deliver the correct volume of fuel to the cylinders under a variety of conditions.

Fuel is pressurized by the fuel pump and flows to the fuel injectors. A pressure regulator, located in the fuel tank or after the injectors, regulates fuel pressure. The ECM controls when and how long the fuel injectors are on. The injectors, when on, allow fuel to flow into the intake manifold. The ECM calculates how much fuel to be injected based on a variety of parameters, primarily temperature and intake air volume.

There are other components used on a fuel injection system to modify its operation and are covered in the fuel system section.

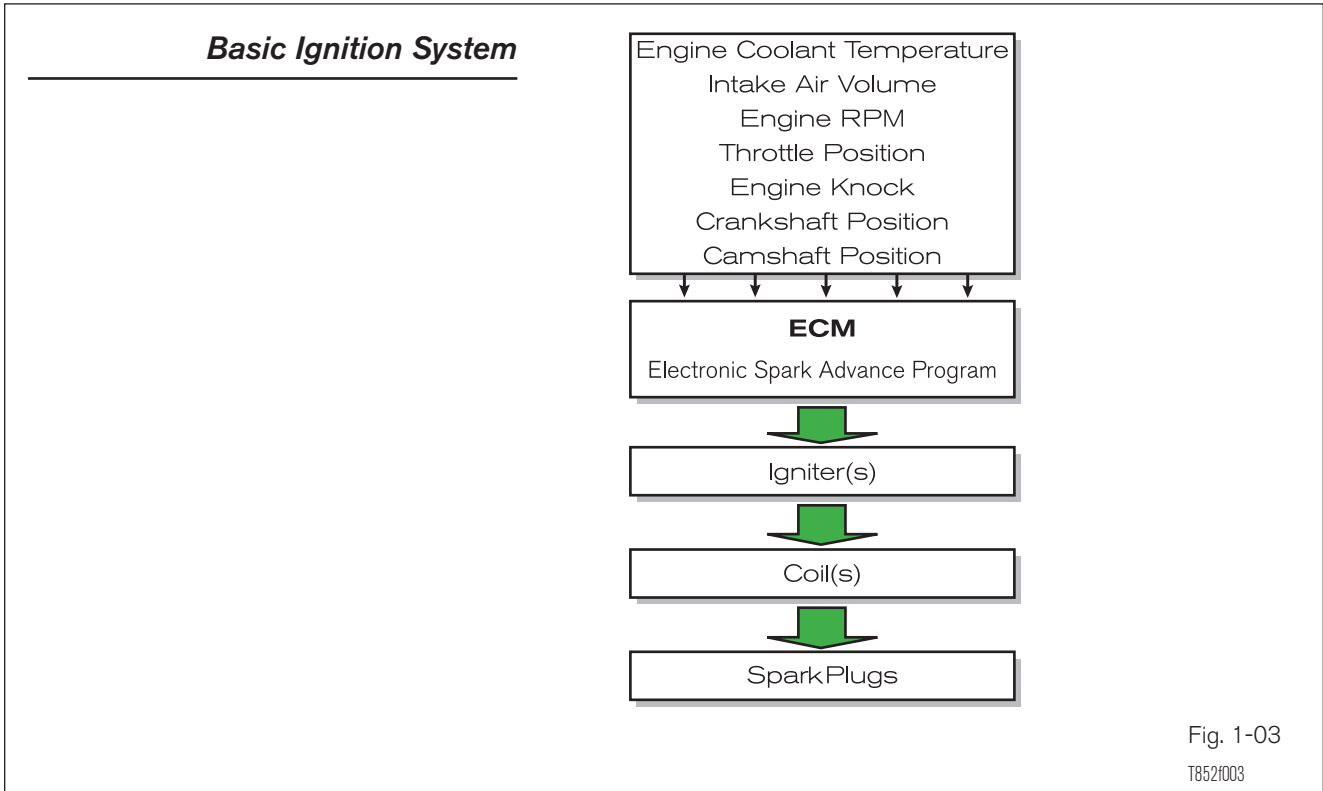

Ignition Systems Based on engine operating conditions, the ECM determines when to ignite the air/fuel mixture according to its programming. The igniter turns the ignition coil(s) on and off based on a signal from the ECM. The high voltage needed to create the spark is generated in the coil(s).

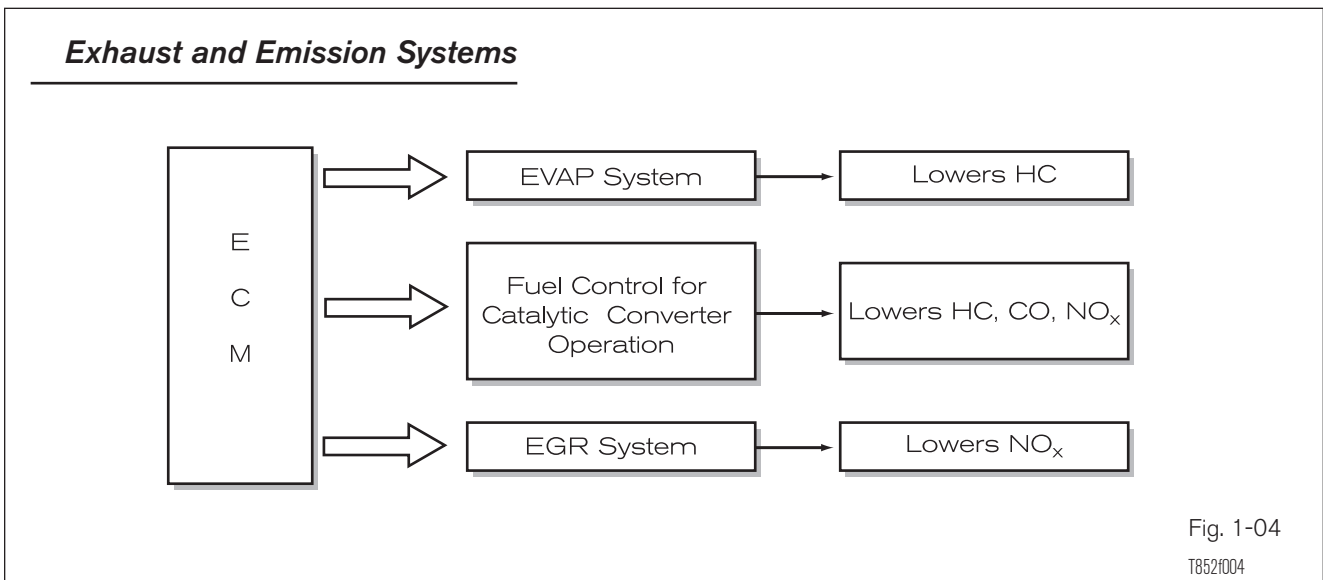

Exhaust and Emission Systems The ECM manages systems and components to meet regulations. The evaporative system (EVAP) prevents gasoline vapors (HC) from entering the atmosphere. The fuel control program adjusts the air/fuel ratio so the catalytic converter runs at peak efficiency. This lowers hydrocarbons (HC), carbon monoxide (CO), and oxides of nitrogen (NO_x). The exhaust gas recirculation system (EGR) also helps to lower NO_x.

Other Systems Engine components that were once mechanically controlled are now electronically controlled. The goal is better engine efficiency and vehicle safety. Some of these systems are:

- Electronic Throttle Control-intelligent (ETCS-i) - the ECM adjusts throttle opening according to driver demand and vehicle conditions. This enhances vehicle performance and safety.
- Acoustic Control Induction System (ACIS) - the ECM will vary the effective intake runner length for better engine performance.
- Variable Valve Timing-intelligence (VVT-i) - the ECM adjusts when the valves open to provide better fuel economy, horsepower, and lower emissions.

There is no doubt that these systems will be modified and new systems added as new models are introduced.

Another significant trend is the integration of individual systems. For example, the ECM works in coordination with the Vehicle Stability Control system to provide better vehicle control in slippery conditions.

Basic Electronic Engine Control System

The following chart shows a basic electronic engine control system. Sensors provide the needed data. The ECM will send the appropriate signal to the actuators.

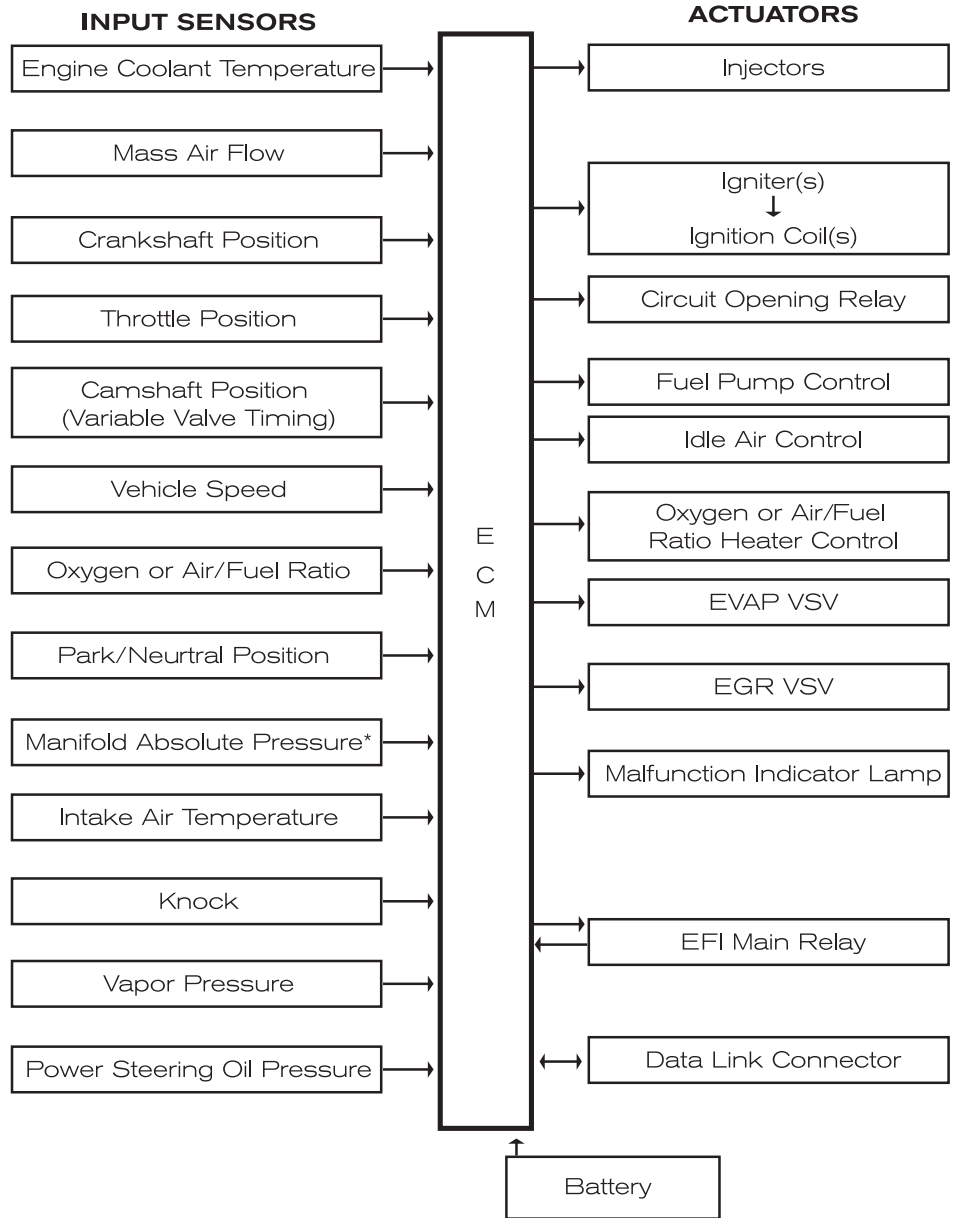

**Mass Air Flow (MAF) sensor equipped engines do not use a manifold absolute pressure sensor. All Lexus engines use MAF sensors.*

Fig. 1-05

T8521005

Electronic Engine Control Systems

The electronic engine control system consists of sensors that detect various engine conditions, a computer called the Electronic Control Module (ECM), and numerous actuators that control a variety of engine components.

Accurate diagnosis of the electronic engine control system consists of several elements:

- fundamental knowledge of how the system works
- finding the correct repair information
- correctly interpreting data from the engine control system
- performing the proper tests accurately

To understand how the ECM controls various engine functions, the electronic control system is divided into three sections:

- input
- process
- output

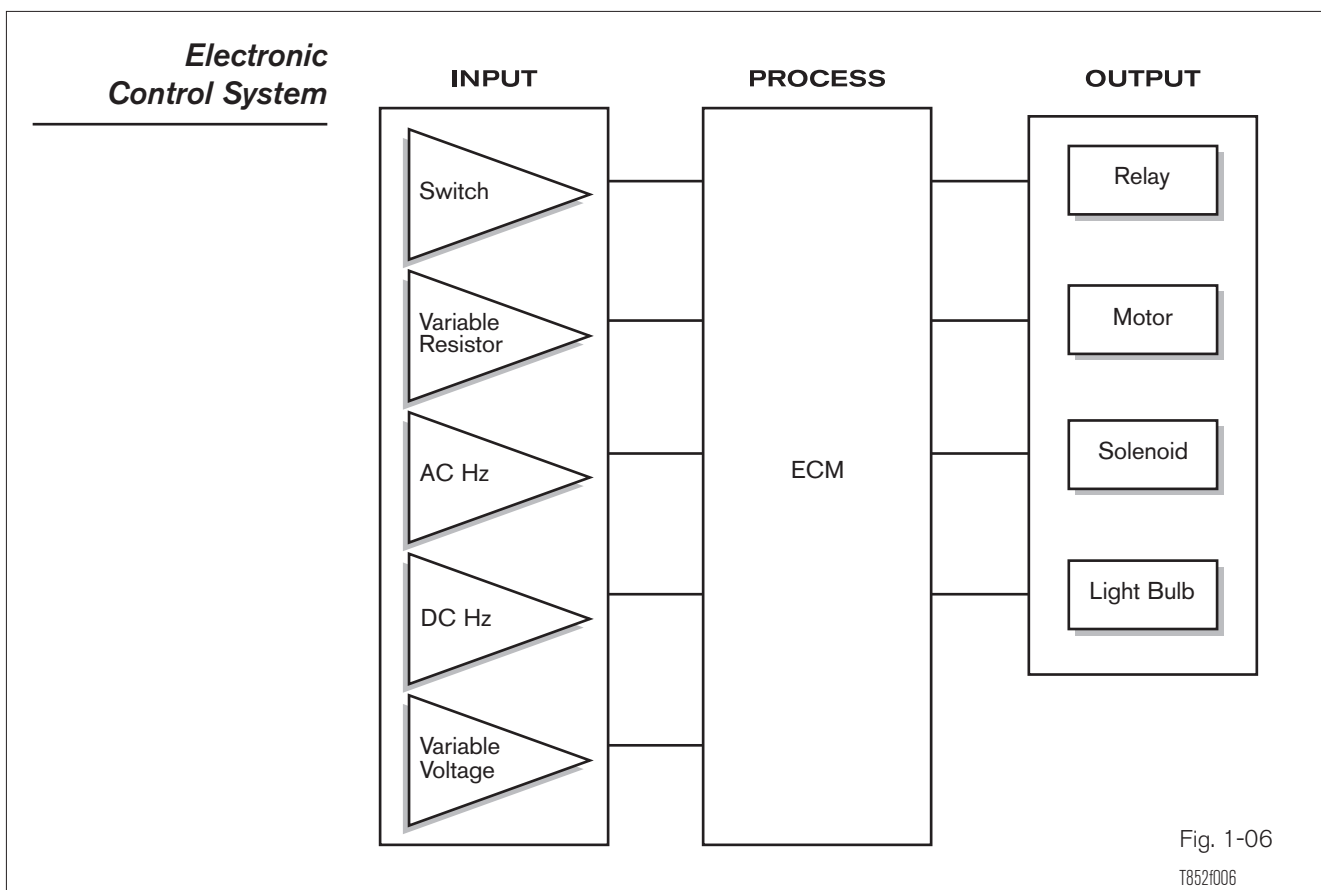

Inputs

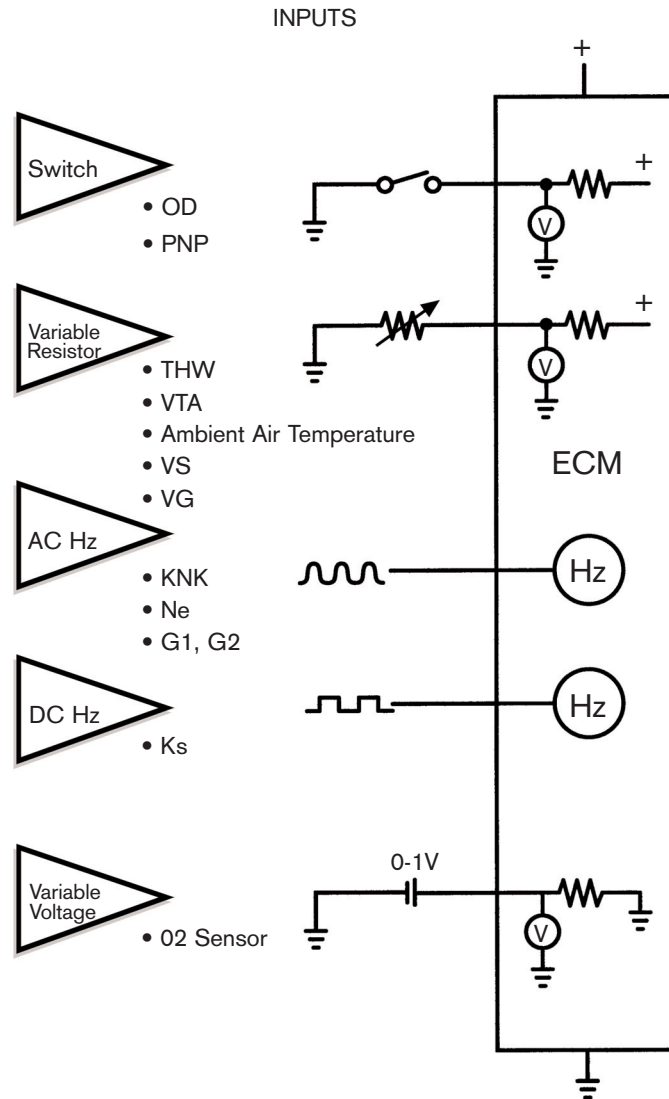
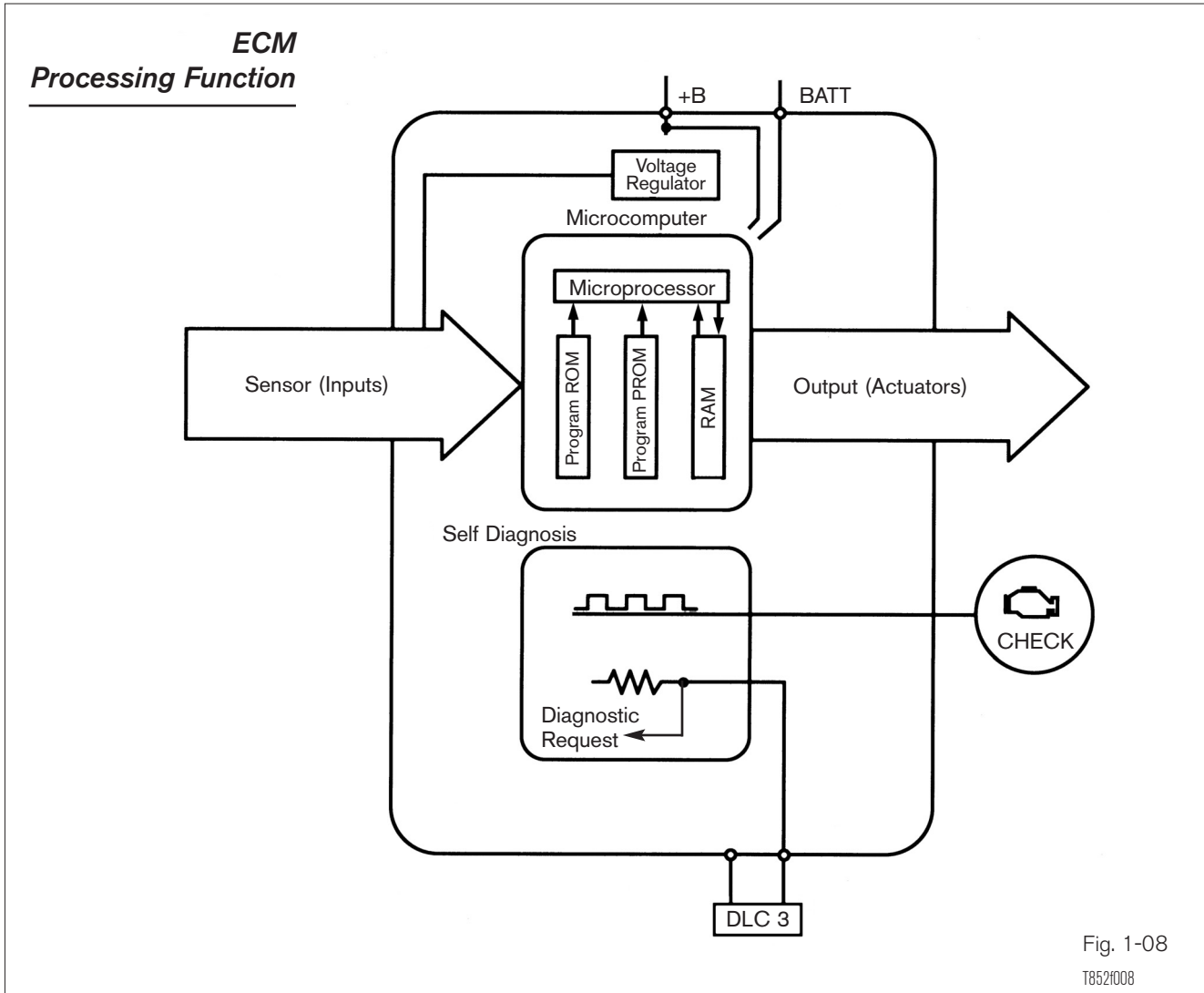

Fig. 1-07
T852H007

Inputs Sensors are used to convert engine operating conditions like temperature, rpm, throttle position, and other parameters into electrical signals which the ECM constantly monitors. Electronic circuits built into the ECM sense some circuits, (like the electrical load circuit) for proper operation. With this data, the ECM has sufficient information to run the programs that operate the engine and emission control systems.



Engine Control Module (ECM)

The ECM processes the input signals, arrives at a decision based on its programming, and carries out the needed action. The ECM also stores in its memory vehicle/engine information to make certain the vehicle performs as prescribed, Diagnostic Trouble Codes (DTC) and other diagnostic information. The ECM may also control other functions such as transmission/transaxle control.

The latest ECMs also contain the vehicle information number (VIN), calibration identification (CAL ID), and calibration verification. This is done to insure the calibration settings are correct for that vehicle/engine.

ECMs should be handled with care. Electronic components are sensitive to electrostatic discharge (static electricity). Always follow the recommended procedures when handling these components.

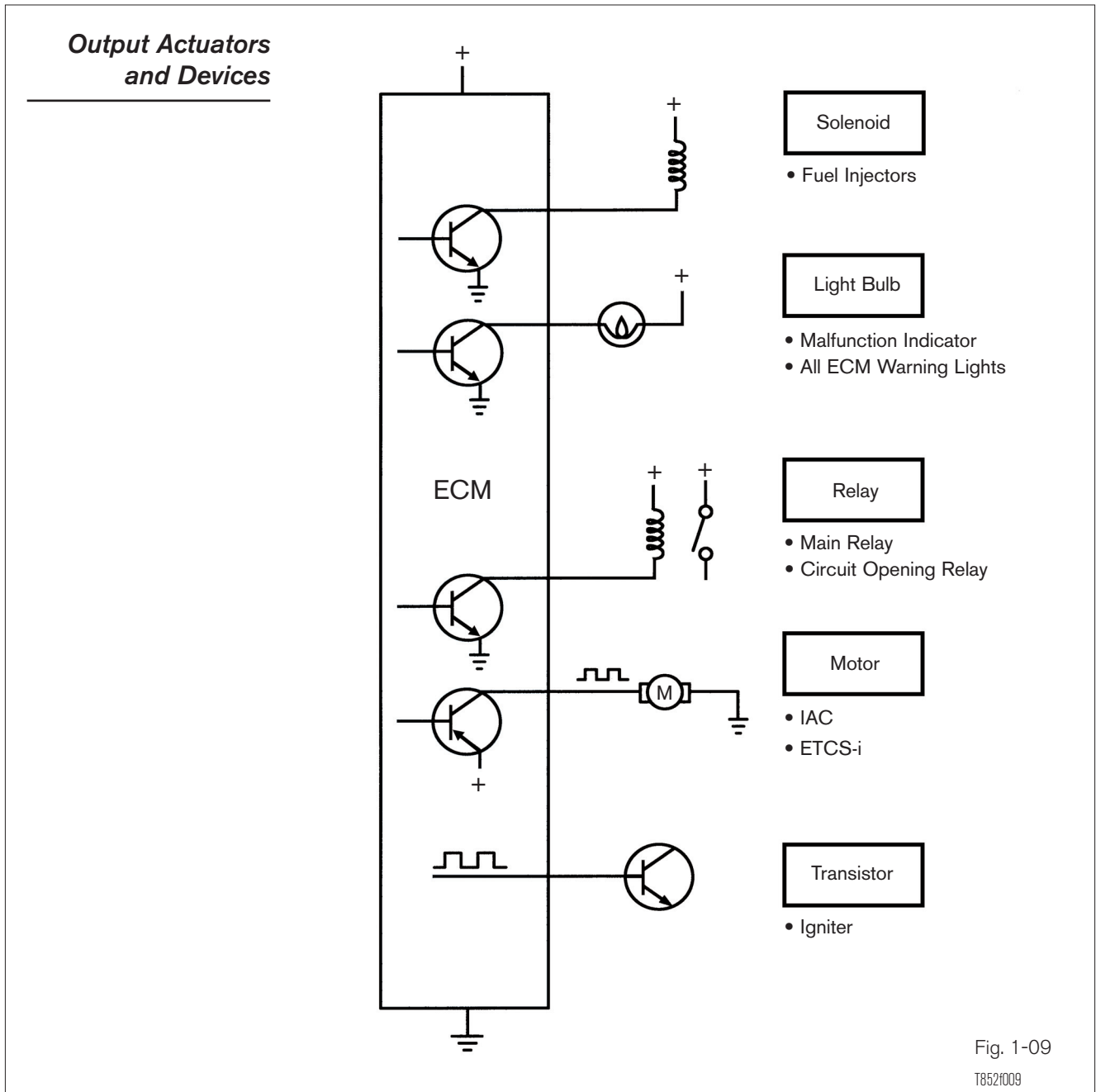

Outputs (Actuators) Output commands are sent from the microprocessor inside the ECM to the various output driver transistors. The output drivers then turn on or off, causing the actuator (output) device to turn on or off.

Types of output actuators are:

- Solenoids - Fuel Injectors, Vacuum Switching Valves (VSV)
- Relays - Circuit Opening Relay

- Transistors - Igniter
- Lights - Malfunction Indicator Light (MIL)
- Motors - Electronic Throttle Control Motor
- Heater(s) - Oxygen and Air/Fuel Ratio sensor heaters
- Clutch - Electronic Throttle Control

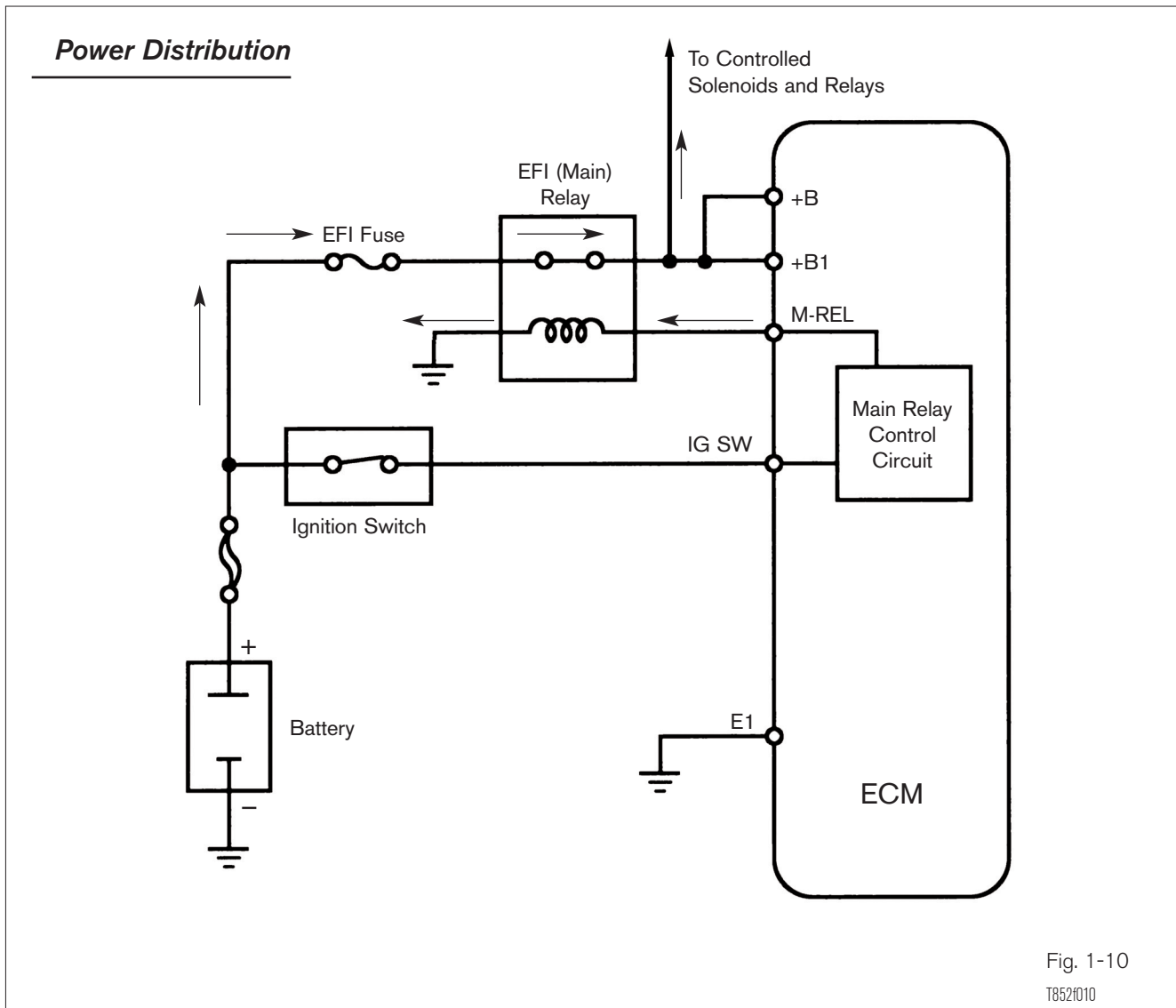

Power Distribution When the ignition switch is turned on, current is supplied to the ECM initializing the computer program, and supplying electrical current to all of the system controlled solenoids, relays, and motors. The current operating the ECM returns to ground through E1. Without a properly

operating power distribution circuit, the ECM and engine will not function and there will be no communication with the Diagnostic Tester.

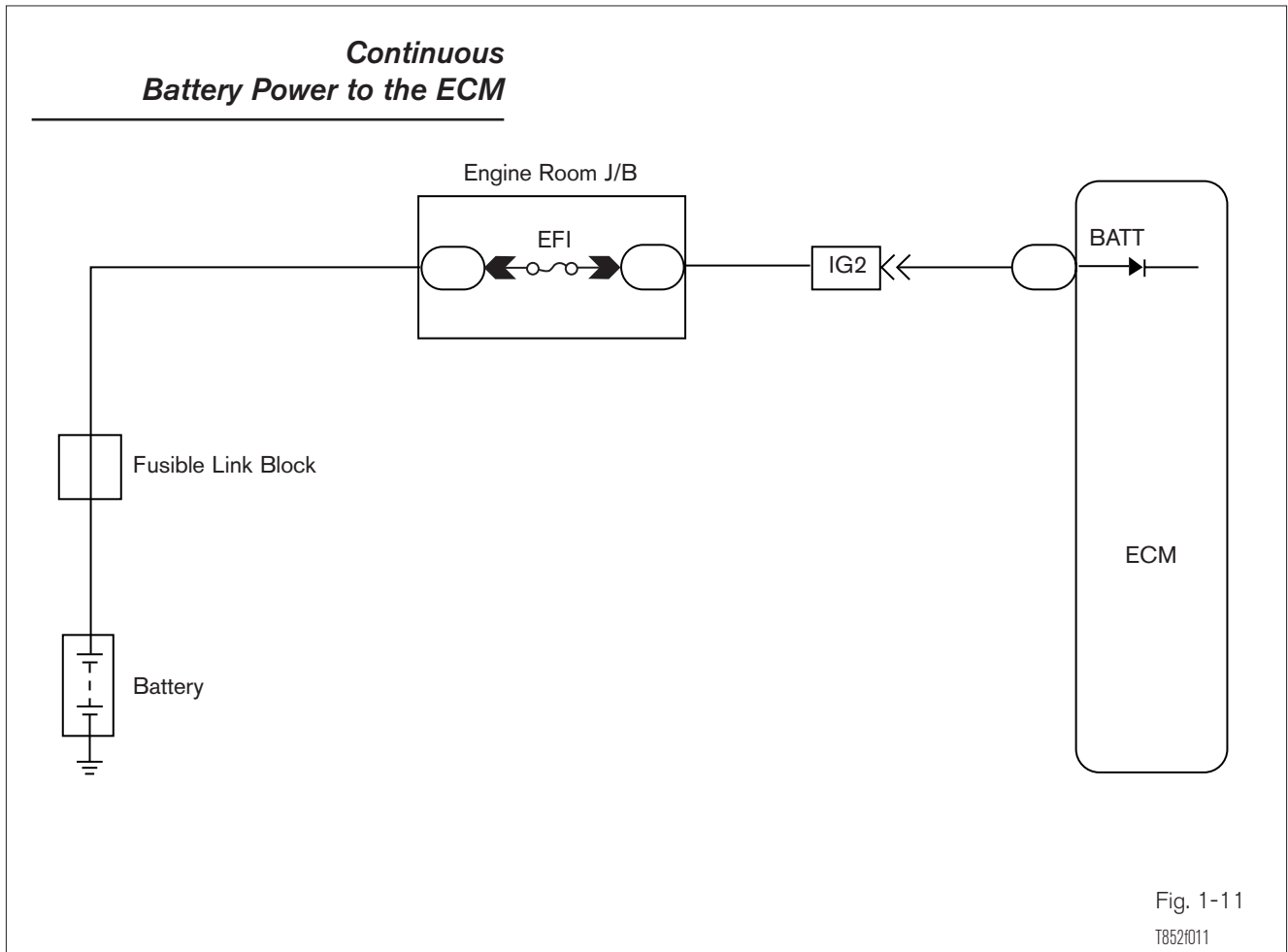

The ECM also has another battery power line used to store DTCs, ignition timing, fuel trim, and other values stored in memory. If there is no power at this terminal, DTCs and other stored memory values are erased.

Voltage Control Signal The ECM sends out a regulated voltage of 5 volts on the voltage control (VC or VCC) signal line. This voltage is used for many sensors such as temperature sensors, position sensors, throttle position sensors, etc.

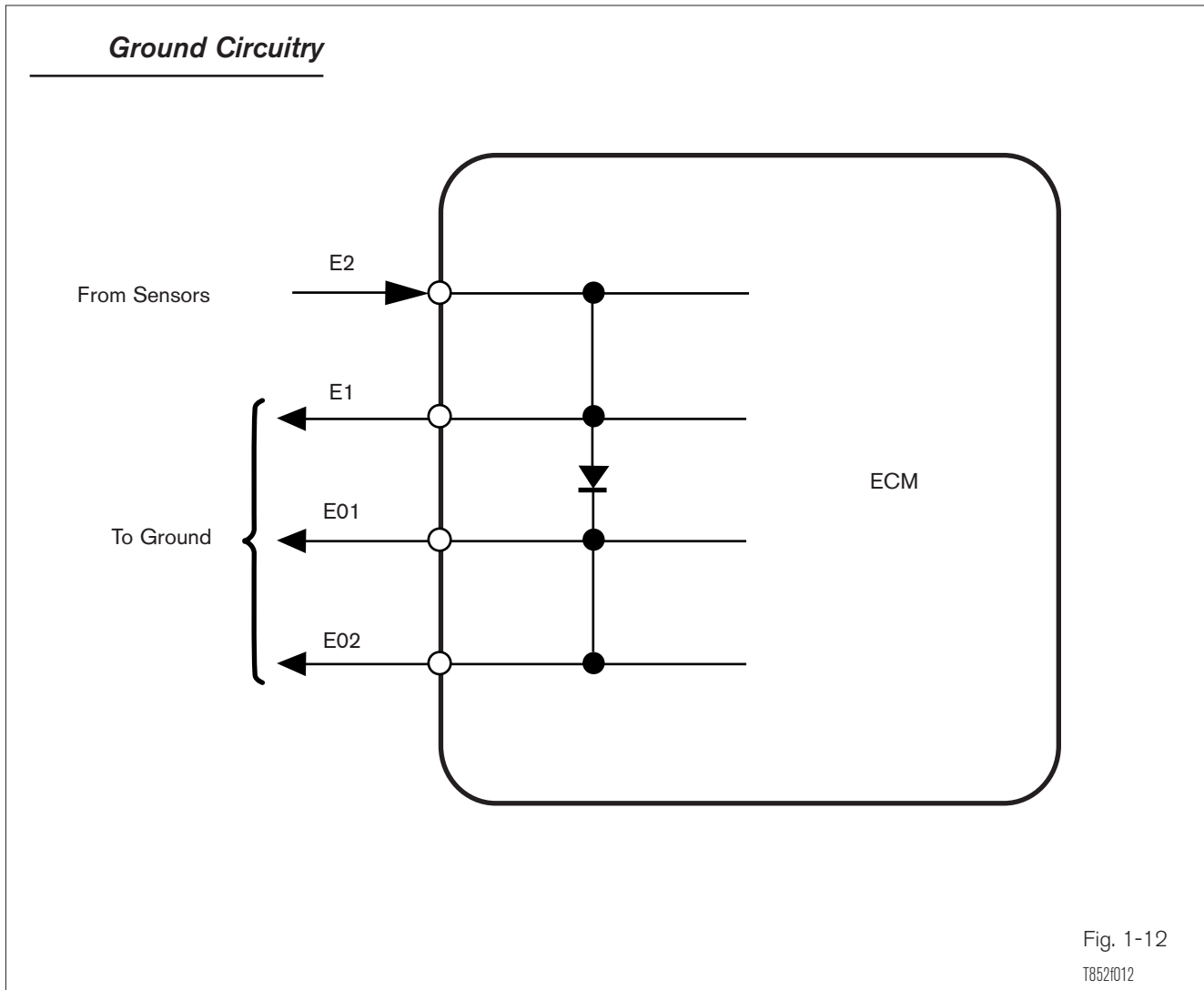

Ground Circuits The ground circuit is equally as important as the power circuits. The ECM has multiple grounds, and is usually the ground path for sensors and actuators. The number of grounds will vary with engine and model year.

Ground circuits are often checked by measuring the voltage drop, and the wires are checked for continuity.

Despiking/ Clamping Circuits When a circuit that carries a large current is suddenly turned off, a high voltage is induced in the coil windings found in relays and solenoids. This high voltage spike can damage the transistor in the ECM, generate a false signal in other circuits, or generate radio noise. A diode or resistor prevents these things from happening. The diode or resistor is connected in parallel to the coil winding limiting the high

voltage spike. An ECM that is frequently being replaced for the same cause may have a damaged despiking diode/resistor in the circuit.

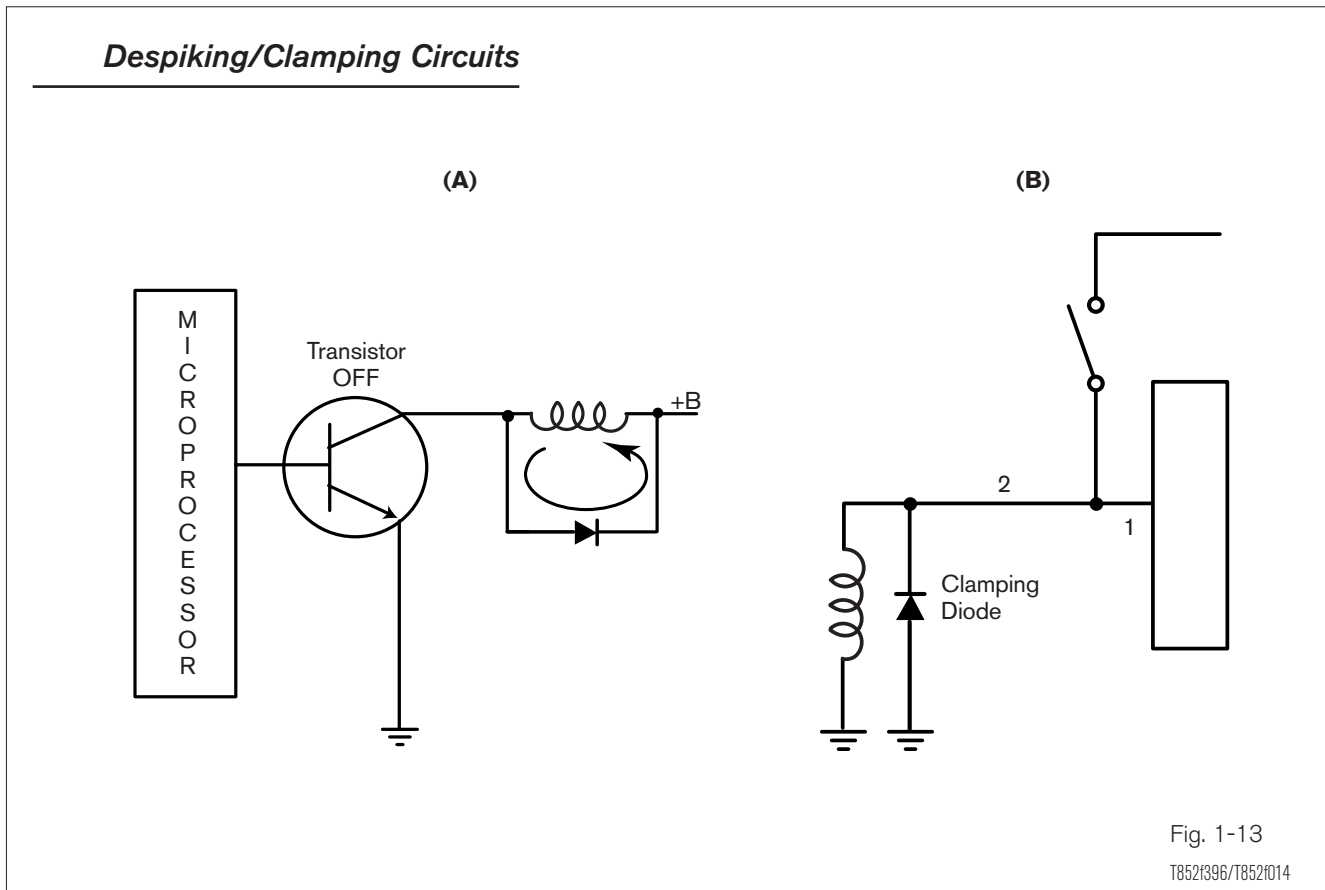

Clamping Diode (A) During normal operation (circuit on) the diode is connected with a polarity that will not allow it to conduct. When the circuit is turned off, the collapse of the magnetic field across the coil induces a voltage in the opposite direction. The diode conducts this induced voltage preventing a voltage spike and damage to the ECM.

(B) With the switch closed, current flows in circuit 2 energizing the coil. Circuit 1 tells the ECM the circuit is on. The diode will not conduct current as this time.

When the switch is turned off the magnetic field around the coil collapses. This collapse generates a voltage in the coil with opposite polarity (top-negative, bottom-positive). This polarity is correct for the diode to conduct, so current will flow through the diode. This will prevent voltage from building on circuits B and A and prevent high voltage from damaging the ECM.

Resistor Clamping Circuit

A resistor can be used for the same purpose.
 The resistor has a very high resistance in relation to the circuit (400-600 Ohms). The resistor provides an alternative path preventing the high voltage spike

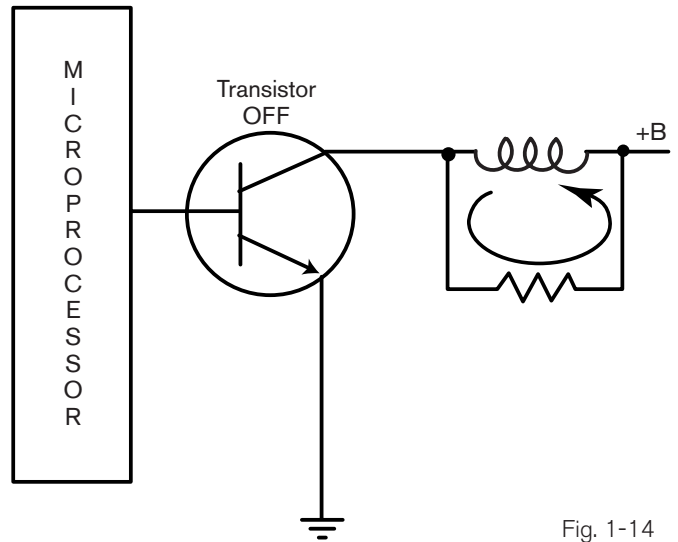

Fig. 1-14
 T852f015

Diagnostic Link Connectors

Three types are shown here. DLC1 is found under the engine hood.
 DLC2 is found in the passenger compartment, drivers side.
 DLC3 is found within a foot (right or left) of the steering column.

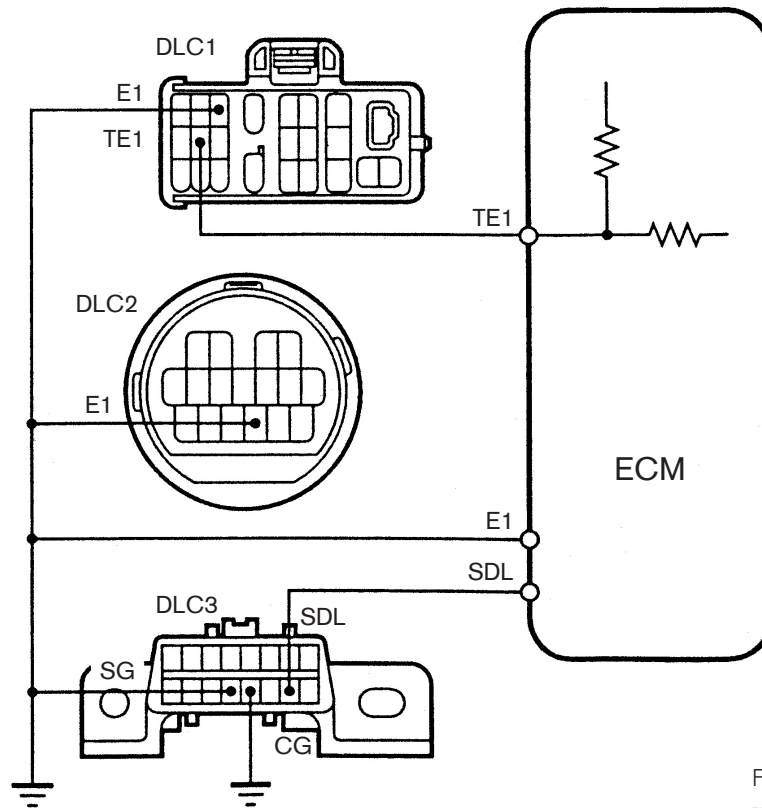

Fig. 1-15
 T852f016

Diagnostic Link Connectors The Diagnostic Link Connector (DLC) provides a way to communicate with the ECM and simplifies many diagnostic procedures.

Three types of DLCs have been used, and some years will have all three. OBD II regulations require a standard DLC for vehicles, and it is referred to as DLC3.

EngineControl System Diagnostic Information Knowing where to find the information can save you time. The following is an explanation of the information resources are needed for accurate and timely repairs.

Repair Manual The Repair Manual (RM) contains the following sections (note: this section follows the 1996 and newer format).

Introduction (IN) This section contains how to troubleshoot ECU controlled systems, the abbreviations used and a glossary of terms. You will find the troubleshooting procedures and where to find more information.

Diagnostics (DI) This part is the most used section for diagnosing engine control system concerns.

- **Pre-Check** contains an overview of obtaining DTCs and Freeze Frame. Also, it describes what to do if there is no communication between the ECM and Diagnostic Tester.
- The **Fail-Safe Chart** is used indicating ECM strategy when certain DTCs are set.
- The **Basic Inspection Section** is a fundamental check of air, fuel, and spark.
- **Engine Operating Condition** explains the items displayed on the Diagnostic Tester and show normal condition signals.
- The **Diagnostic Trouble Code Chart** displays all the applicable DTCs for that engine, possible trouble areas, and the page to turn to to diagnose the DTC.
- **Parts Location** shows a picture of the vehicle where the major components are found.
- **Terminals of the ECM** shows a view of the ECM and its connectors as you would view them. This view is NOT in the EWD. This is a very useful view for knowing which circuit to find and test. You will also

find the wire colors, signal acronym and standard voltages at each terminal.

- **Problem Symptoms table** is used when there is no DTC displayed to direct you to the appropriate area.
- **Circuit Inspection** is where the DTCs are diagnosed. At the end of this section, after the last DTC diagnosis, you may find the Starter Signal Circuit, IACV Control Circuit, ECM Power Source Circuit and Fuel Pump Control Circuit diagnosis.

Emission Control (EC) Shows component checks of emission system components such as the EVAP canister, EGR system, etc.

Sequential Fuel Injection (SFI) This section contains the component check for the sensors and actuators of the fuel injection system. Here you will find how to remove and test components.

Ignition System (IG) This section shows how to check ignition system components.

Electrical Wiring Diagram Manual (EWD) The EWD manual provides you sections and overall view of the engine control system with power circuits, ground circuit, connectors and associated numbers, and a brief description of operation. Because the wires are provided in color, it is often easier to use the EWD to locate components and related signals by wire color, then use the ECM connector view in the DI section to determine where to connect a DVOM or oscilloscope.

Diagnostic Tester Manual This manual comes when a Diagnostic Tester is purchased. Updates are provided when the software card is updated. This manual provides you with operation of the tester in a variety of modes.

Technical Service Bulletins (TSB) These bulletins provide you with the latest solutions and corrections that are not provided in the Repair Manual.

Hotline Support The hotline is for those problems when you need advice when all other methods did not lead to a solution. It is critical that you provide and record all DTCs, conditions when symptoms occur, and what has been done to repair the concern. Accurate information is vital - write it down.

Technical Information System (TIS) This networked computer system will provide you with all the above information in one location. The significant advantages of TIS is that large quantities of the latest information can be retrieved from one source, and the information can be accessed by a variety of methods.

History of On-Board Diagnostics

This section is a summary of emission control regulations and will provide background on the regulations that relate to On Board Diagnostics. The emphasis is placed on the differences between On Board Diagnostics, generation 1 (OBD) and On Board Diagnostics, generation 2 (OBD II).

Federal and state efforts to improve air quality over the years have created regulations that influence the design of the emission and engine control systems on all vehicles. Standards are set to provide regulation, monitoring, and enforcement to achieve mandated goals. On Board Diagnostics (OBD) monitor the vehicle's systems and components and report failures through Diagnostic Trouble Codes (DTC). The state of California has been instrumental in setting emission standards. For this reason, systems have appeared on California vehicles before appearing on vehicles sold in other states (Federal Vehicles). Today federal and state standards may vary, but the equipment and monitoring systems are essentially the same.

OBD Objectives The primary objective of OBD systems is to reduce vehicle emissions and the possibility of further damaging emission components by detecting and reporting a malfunction. To meet that objective:

- The driver is alerted of a malfunction in the emission control system by the Malfunction Indicator Lamp (MIL).
- All vehicles are certified to meet or exceed emission standards. OBD systems are designed to monitor and report malfunctions when emission output will exceed mandated standards.

OBD (On-Board Diagnostic System, Generation 1)

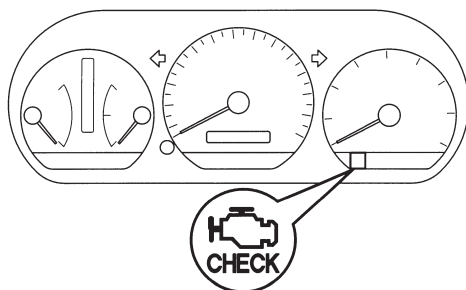

- Current related checks (open or short)
- Limited system monitoring (A/F & EGR)
- Minimal use of rationality checks
- Limited DTCs
- Limited use of Serial Data
- System and component names not standardized
- DTCs not standardized

Fig. 1-16

T852/017

OBD (On-Board Diagnostic System, Generation 1)

In April 1985, the California Air Resources Board (CARB) approved On-Board Diagnostic system regulations, referred to as OBD. These regulations were phased in beginning in 1988 to include cars and light trucks marketed in the State of California. They required that the engine control module (ECM) monitor critical emission related components for proper operation and illuminate a Malfunction Indicator Lamp (MIL) on the instrument panel when a Malfunction was detected.

Although the OBD regulations initially apply to California emissions certified vehicles, some or all of the OBD system features are found on Federal emissions certified vehicles as well.

The OBD system uses Diagnostic Trouble Codes (DTC) and fault isolation logic charts in the repair manual to assist technicians in determining the likely cause of engine control and emissions system malfunctions.

The basic objectives of this regulation are twofold:

1. To improve in-use emissions compliance by alerting the vehicle operator when a malfunction exists.