

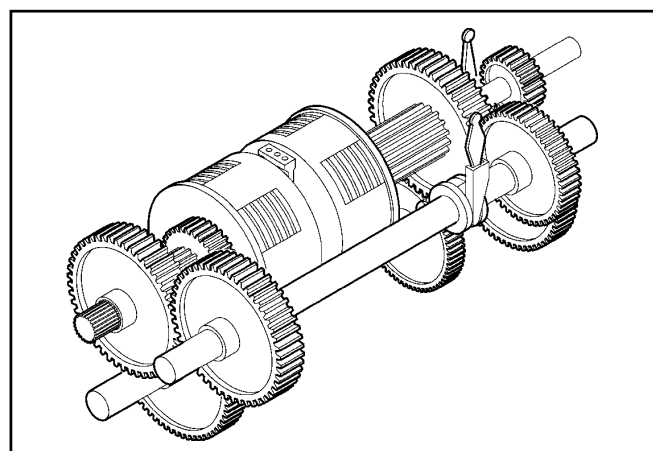

# *Legend*



**Training manual**

Publication P/N 3652037M1

# **Landini**



## ***TABLE OF CONTENTS***

**Chap. 1 INTRODUCTION**

**Chap. 2 THE TRANSMISSION**

**Chap. 3 THE HYDRAULIC CIRCUIT**

**Chap. 4 THE ELECTRICAL SYSTEM**

**Chap. 5 CHECK-CONTROL AND TROUBLESHOOTING**

**Chap. 6 CALIBRATING**

**Chap. 7 SPECIAL TOOLS**

## **PREFACE**

This manual contains the technical specifications, mechanical, hydraulic layouts and wiring diagrams, plus instructions on how to operate and adjust the Deltasix unit installed in Legend tractors. It does not contain all the necessary information as it is completed with the theoretical and practical explanations and theoretical descriptions given by the instructors during the training courses. This information is therefore dedicated to the persons who frequent training courses at the Landini training center.

## **NOTE :**

The descriptions and technical specifications in this manual are strictly not binding. Landini therefore reserves the right to modify the components and accessories for technical or commercial reasons without being obliged to update this manual each time.

The Landini logo is rendered in a bold, italicized, sans-serif font with a thick black outline, giving it a three-dimensional appearance.

**PRE-SALE SERVICE**

*June 2000*

42042 FABBRICO (RE) ITALY



**CHAP. 1**

***Introduction***

**INDEX**

**Sect. 1 Working in safety**

1-1 Essential rules for accident prevention .....	1-4
1-2 Danger decals .....	1-10
1-3 Replacing tractor parts .....	1-13
1-4 Safe use of the tractor .....	1-14

**Sect. 2 Introduction to the DeltaSix transmission**

2-1 Modular transmission .....	1-16
2-2 Deltasix: its target .....	1-17
2-3 Main components .....	1-18
2-4 The performances of the Deltasix transmission .....	1-19



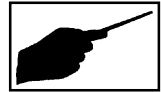

**CHAP. 1**

***Introduction***

**INDEX**

**Sect. 1 Working in safety**

1-1 Essential rules for accident prevention .....	1-4
1-2 Danger decals.....	1-10
1-3 Replacing tractor parts .....	1-13
1-4 Safe use of the tractor .....	1-14



## *Working in safety*

### 1-1 Essential rules for prevention

The structures, systems and equipment in repair shops must conform to the current laws governing labour safety in order to safeguard the health and safety of each worker.

Although they are obviously only partial, the regulations given in this section inform the workers about the dangers they may encounter on the job.

Always bear your safety and that of others in mind whenever you work on a machine, whichever type it may be.

To work in complete safety, it is essential to know the nature of the job, to correctly use the tools and materials required and to rely on your common sense.

**To prevent accidents, it is important to:**

- **BEHAVE** correctly and act with caution;
- Pay **ATTENTION** and keep your actions under control;
- Comply with the **REGULATIONS** and rules of behaviour of a general character.



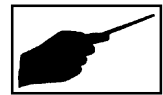

## Working in safety

### 1 - Rules of a general character

#### Preliminary instructions

- always comply with the instructions received from superiors;
- always comply with the indications on the stickers and signs;
- never use machines or systems without authorization and never carry out operations and manoeuvres that are the competence of others;
- use the safety devices and other means of protection with care;
- inform your superiors if the safety and protective means and devices are defective or about any danger conditions of which you may become aware;
- never remove or modify the safety devices and other means of protection without having been authorized to do so;
- Let your superiors know immediately about any accidents you have had or about which you may have become aware;
- keep your place of work clean and orderly. Keep the floor clear of any materials that are not strictly required for the job in hand and prevent greasy or oily substances from being spilt (clean them up with absorbent paper if this should occur).

#### Work clothes

- Do not wear loose clothing that can become caught up in moving parts or garments that are not tight at the cuffs;
- do not wear necklaces, rings, bracelets and similar;
- do not clean the garments with inflammable or harmful substances, or using compressed air;
- do not wear sandals, slippers, clogs or shoes with high heels.

Always wear protective clothing (goggles - visors - gloves - footwear, etc.).

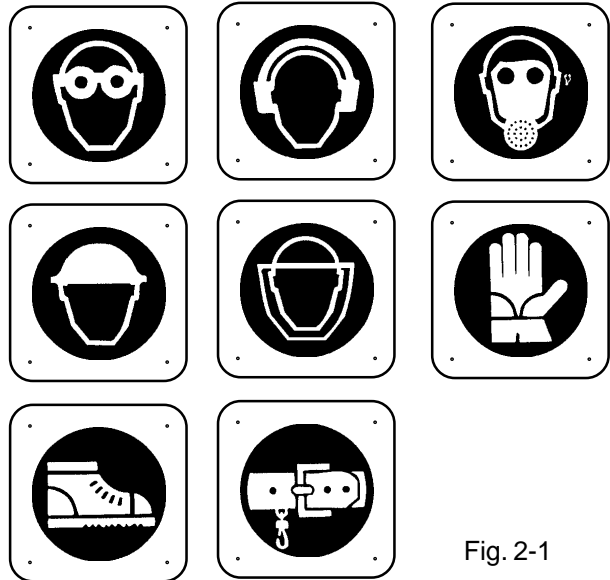

Fig. 2-1

#### Machines and systems

- Before beginning work, make sure that the guards and screens are in place, in a good condition and that the safety devices are functional;
- check the operation of any exhaust or ventilating systems installed;
- never remove the guards or safety devices from the machine unless this is strictly necessary and after having been authorized to do so by your superiors, who will also indicate the precautions that must be taken;
- the protections and safety devices must be fitted back in place and be re-activated as soon as the reasons for their having been temporarily removed have ceased;
- it is forbidden to clean, oil or grease moving parts of machines and systems by hand.
- it is forbidden to adjust or work on moving parts.





## **Working in safety**

### **Lifting and carrying**

#### **By hand**

- do not bend your back to lift loads;
- hold the load safely where it is easy to get a good grip;
- do not carry loads with greasy or oily hands;
- hand trucks without drawbars should be pushed, not pulled;
- never deposit loads near stairs, fire-fighting systems, first-aid means or places of transit.

#### **On vehicles**

- comply with the capacity limits and regulate your speed according to the road conditions, the load, and the braking distance;
- make sure the loads are well harnessed and fastened;
- avoid passing with hanging loads in places where dropping could cause a danger hazard. If this is inevitable, indicate when the manoeuvre is made or have all bystanders move out of the area.

### **Internal circulation**

#### **People**

- use the correct and authorized routes (pedestrian crossings, gangways and similar);
- do not run;
- do not walk or stand under hanging loads or in places where loads could drop;
- do not ride on means of transport or lifting equipment designed for handling materials alone.

### **Vehicles**

- proceed at a moderate speed and with due care, depending on the road conditions. Comply with the farm/company rules and with the road signs.

### **Electricity**

- do not make electrical connections with makeshift means and never ever insert the ends of wet conductors into sockets;
- disconnect plugs from sockets by holding the outer casing, never by pulling the electric cable;
- avoid twisting the cables;
- frequently check the insulating material of conductors and electrical equipment and make sure that it is in a good condition;
- point out any damage to electrical equipment and systems, with particular reference to the condition of the ground conductors;
- do not open cabinets or containers housing electrical equipment or carry out work inside unless you are trained and authorized to do so;
- watch out for overhead electric lines when approaching or working in their vicinity.

### **Fire outbreaks**

In departments or processes where there may be a danger of fire outbreaks owing to the presence or use of inflammable substances:

- it is forbidden to smoke;
- it is forbidden to use equipment with naked flames or to handle glowing materials;
- do not place inflammable materials near heat sources;
- do not store materials in front of extinguishers or fire hydrants;



# Working in safety

## Dangerous substances and preparations

Take the following precautions when using dangerous chemical products (fire, explosion, irritation, caustic burning, scalding, intoxication):

- only keep receptacles containing dangerous products open for the time strictly required for their use;
- do not use or transfer dangerous products into containers that are not designed for this use, or into those without indications as to their contents or without the relative markings;
- comply with the indications on the relative labels when using chemical products.

## Defence against gas, fumes, dust, harmful vapours

- make sure that the exhausting systems are operating;
- wear protective clothing and equipment;
- install temporary exhausts as near as possible to the sources, if necessary;
- do not work in the direction of the flow of polluting substances blown out by exhaust systems.

## Agents of a biological nature

- in the event of fermentation (development of algae), avoid direct contact and act with appropriate protective means. Only enter places where anaerobic fermentation may have taken place and produced fumes (e.g. ammoniacal) after having worn a protective mask.





GUIDE TO CHOOSING THE RIGHT EXTINGUISHER					
TYPE OF FIRE	EXTINGUISHING AGENT				
	WATER	POWDER	CO <sub>2</sub>	FOAM	SPECIAL POWDERS
<b>A</b>  Ordinary solid fuels	YES	YES	YES <small>Only for small fires. Does not extinguish the embers</small>	YES	NO
<b>B</b>  Inflammable liquids	NO	YES <small>Unless suitable equipment is used</small>	YES	YES	NO
<b>C</b>  Inflammable gases	NO	YES	YES	NO	NO
<b>D</b>  Combustible metals	NO	NO	NO	NO	YES <small>May react with water</small>
<b>E</b>  Electrical equipment	NO	YES	YES	NO	NO

Fig.3-1



## Working in safety

### 2 - Tools

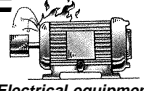
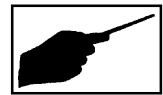
Makeshift, inadequate or defective tools may cause faults or accidents. Never use the wrong tools since such action could cause injuries and spoil the finished job.

Always use the special tools recommended by the manufacturer when demounting, overhauling and re-mounting the various parts of a tractor. (Fig. 6-1)  
-Use of specific tools will reduce the effort and time required for the job and, consequently, the cost. You will also be certain that the work has been correctly done.

Never use:

- A hammer with a loose head or cracked handle.
- Pincers or pieces of iron instead of a hammer; drill bits or bolts instead of pin drivers.
- Worn or welded wrenches.
- A steel hammer to tap bearings or stress relieved components (use one made of bronze or brass).

The engine and gearbox and the front and rear transmissions must be split for certain jobs on the tractor components. This operation is facilitated and made safer by use of the special divider kit (Fig.7-1).

When lifting weights, make sure that the chains, lifting brackets, hooks, cables or ropes comply with CE standards.

Unless different indications are given, an adjustable bracket must be used when particularly heavy parts are removed.

All chains and cables must be parallel to each other and as near to the vertical as possible, depending on the component being lifted.

### C - First Aid

Mechanics are exposed to various risks at work. If anyone should be injured, use sterile materials and disinfectants for first aid purposes. These materials should be kept in the first-aid box, equipped in compliance with the laws in force.

31 DIF GL  
Tool used to mount the bushing on the differential housing.

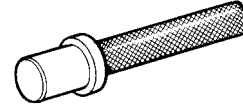

32 DIF GL  
Tool used to insert the external rings on the taper bearings of the rear differential (43 Fig.92/93-5)



33 DIF GL  
Puller for the normal and fast upper shaft on the differential housing (16 Fig.113-5)

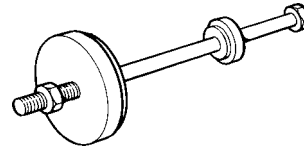

34 DIF GL  
Tool used to mount the needle bearing on the slow reduction range gear shaft (15 Fig.52/53-5)

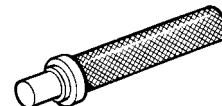

Fig.4-1

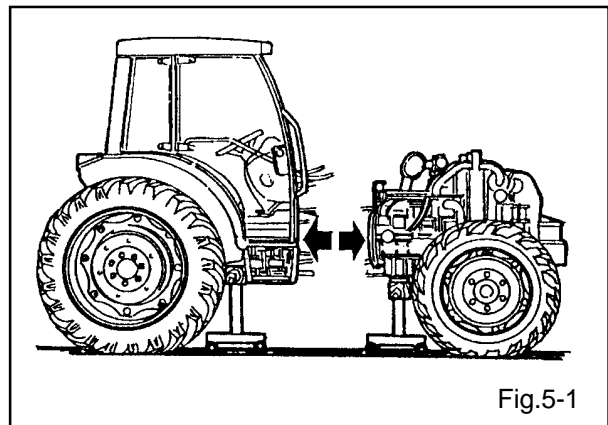

Fig.5-1

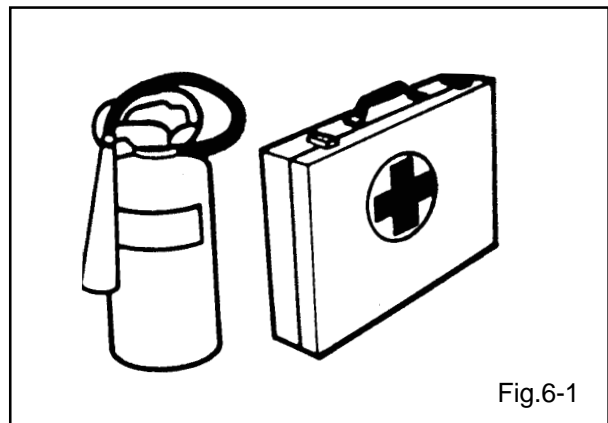

Fig.6-1



## ***Working in safety***

### **4 - Tractor safety regulations**

#### **Note**

**Before getting into the tractor, it is essential to read and strictly comply with the instructions in the operation and maintenance manual.**

#### **Starting**

- Never start the engine in a closed space without an adequate ventilation system able to eliminate the gas fumes;
- Never place your head, body, limbs, feet, hands or fingers near spinning belts or fans.

#### **Engine**

- Unscrew the radiator plug very slowly to relieve the pressure from the system before taking it completely off. Coolant fluid must only be topped up with the engine at a standstill or idling, if hot.
- Do not refuel the engine whilst the engine is running, particularly if this hot. Such action could cause a fire outbreak if fuel were to be spilt.
- Never attempt to check or regulate the tension of the fan belts whilst the engine is running. Never adjust the fuel injection pump when the tractor is moving.
- Do not lubricate the tractor when the engine is running.

#### **Electrical system**

- If auxiliary batteries are used, remember that the leads at both ends must be connected to the terminals in the indicated way: (+) with (+) and (-) with (-). Avoid short-circuiting the terminals. **THE GAS ISSUED BY THE BATTERIES IS HIGHLY INFLAMMABLE.**  
When recharging, leave the battery compartment uncovered to allow for ventilation. Never ever check the battery charge by placing metal objects on the terminals as "jumpers". Avoid sparks or flames in the battery zone. Do not smoke as there could be a risk of explosion.

- Make sure that there are no fuel leaks before proceeding with any other operation: eliminate any leaks before continuing work.
- Do not recharge batteries in a closed space: make sure that the ventilation is adequate to prevent the risk of accidental explosions caused by accumulations of the gas issued during the recharging phase.
- Always disconnect the battery before carrying out any work on the electrical system.

#### **Hydraulic Plant**

- A fluid leaking from a very small hole may be almost invisible but have sufficient force to penetrate under the skin. If you need to check for leaks, use a piece of cardboard or wood. **NEVER USE THE HANDS:** if the fluid comes into contact with the skin, immediately seek medical help. Serious infections or dermatitis may occur unless prompt medical treatment is immediately obtained.
- Use suitable tools when checking the pressure values in the plant.

#### **Lifting and lowering**

- Lift and handle all particularly heavy components with lifting means of a suitable carrying capacity. Make sure that the parts are borne by appropriate harness and hooks. Use adequate lifting bolts. Take care of bystanders when lifting the load.
- Handle all parts with the greatest care. Never insert the hands or fingers between one part and the next. Wear approved protective clothing such as goggles, gloves and safety footwear.
- Do not allow metal chains or ropes to twist. Always wear protective gloves when handling cables or chains.



## Working in safety

### 1-2 Danger decals

When replacing a tractor part bearing a sticker with safety warnings (yellow coloured), it is ESSENTIAL to affix the same sticker to the spare part.

A complete list of the places where these stickers are applied is given below.

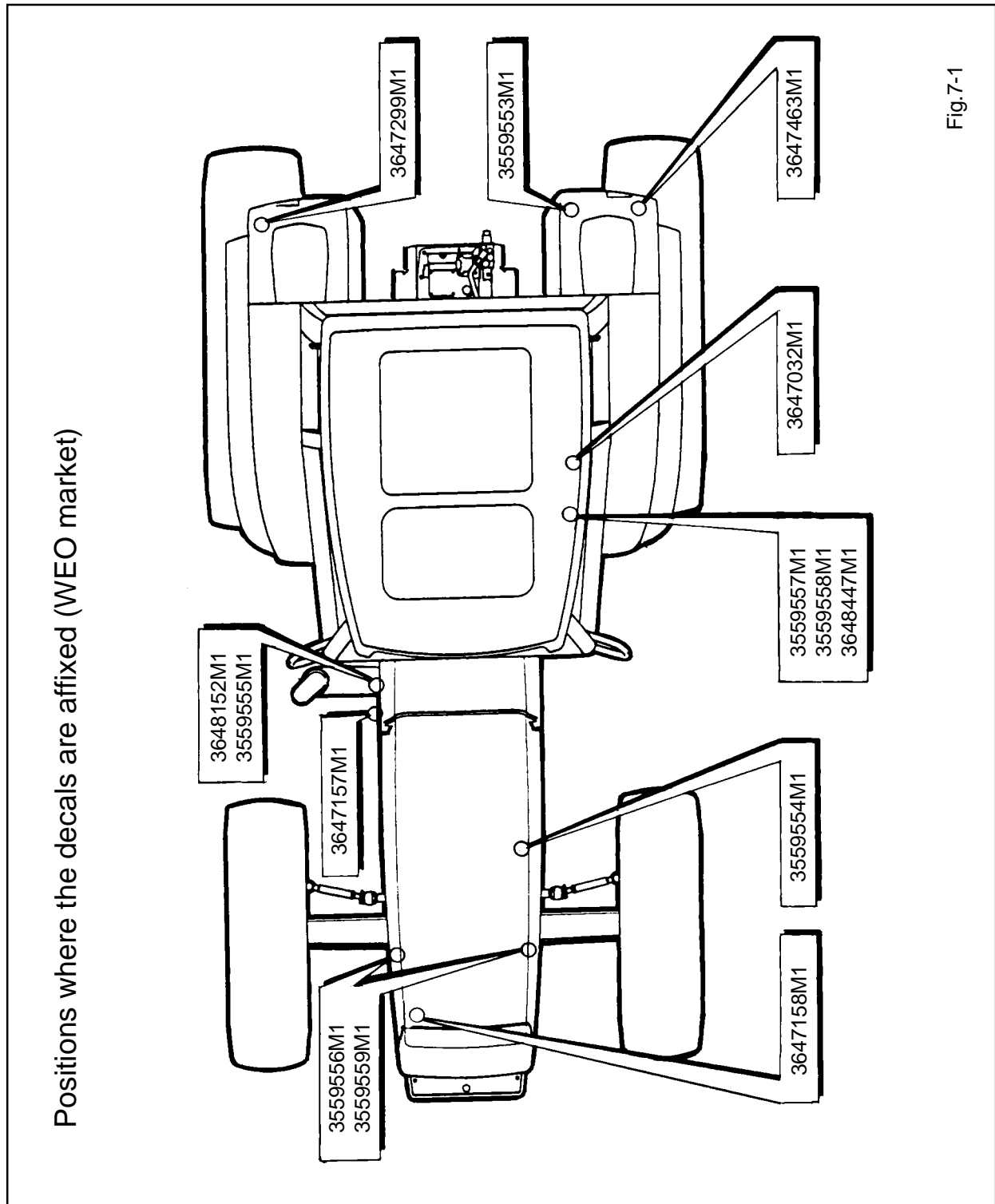

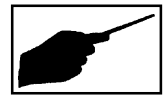

# Working in safety

**3559557M1**

Inside the cab, on the left-hand mudguard covering.

**RISK OF OVERTURNING AND CRUSHING CHEST.** If the tractor is tipping over, hold tightly on to the steering wheel. **DO NOT** leave your seat or jump off the tractor.

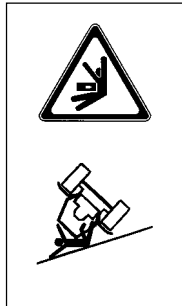

**3559558M1**

Inside the cab, on the left-hand mudguard covering.

**WARNING: CAUTION.** Read the safety and operating instructions in the Operation and Maintenance Manual.

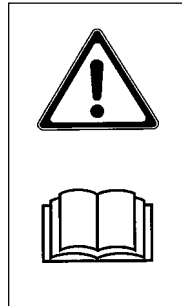

**3559559M1**

On both sides of the radiator, at the base.

**WARNING: HOT SURFACES, RISK OF BURNS TO HANDS AND FINGERS.** Warning. Keep well clear of hot components. Keep at a safe distance.

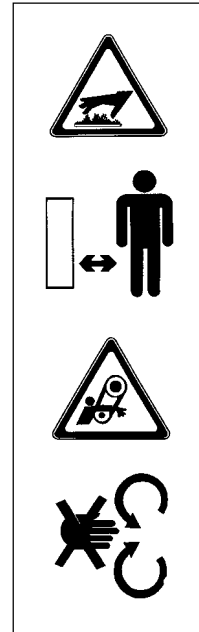

**3559554M1**

On the expansion tank.

**DANGER: HIGH PRESSURE STEAM AND HOT WATER.** Protect your face. Radiator under pressure when engine is hot. Remove cap with caution only when engine is cold.

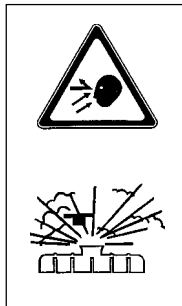

**3647158M1**

On the battery support.

**WARNING: RISK OF ELECTROCUTION.** Always disconnect the negative lead before the positive lead when removing the battery or servicing the electrical system.

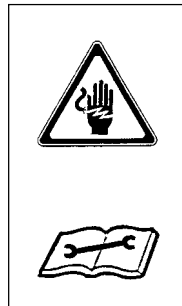

**WARNING: RISK OF ENTANGLEMENT.** Keep hands well clear of moving parts and be careful not to get caught up in belts or pulleys when the engine is on. Keep guards in place.

**3559556M1**

At top, on left and right-hand sides of the radiator.

**WARNING: RISK OF ENTANGLEMENT.** Keep hands well clear of fan when the engine is running. Always keep guards and shields in place.



**3647032M1**

In cab on the left-hand pillar for tractors without 2nd passenger seat or with frame.

**WARNING: RISK OF BEING CRUSHED.** **DO NOT** let any passenger sit on the mudguards or on any part of the tractor or implements being towed.



**3648152M1**

On starter motor.

**RISK OF ELECTROCUTION.** **DO NOT** short across starter terminals to start the engine. This operation could put your life at risk. Start engine only from driving seat.

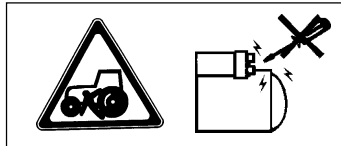

**3647157M1**

Near the oil reservoir of the brake circuit.

**WARNING: RISK OF DAMAGE TO BRAKE SYSTEM.** Carefully read the safety warnings and instructions in the Operation and Maintenance Manual before servicing.

**3648447M1**

On the safety frame of pillar inside the can for tractors with safety belts.

**WARNING: RISK OF BEING CRUSHED.** The safety belt must only be used with the safety frame in the vertical position.



**3559555M1**

On starter motor.

**RISK OF ELECTROCUTION.** Always disconnect the negative terminal of the battery before removing the solenoid cover and before servicing the electrical system.



**3559553M1**

On inside of the rear left mudguard.

**RISK OF ENTANGLEMENT.** Keep clear of spinning shafts. Be careful not to get caught up by the cardan shaft of the PTO driveline. Keep all guards in place on the transmission shafts of the tractor and implements.



**3647463M1**

On the rear left mudguard (only with electronic power lift).

**RISK OF BLOWS AND SERIOUS ACCIDENTS.** Keep to one side of the tractor when using external lift controls. **NEVER STAND** between tractor and implement - you could be hit by the implement.



**3647299M1**

On the rear right mudguard (only with electronic power lift).

**RISK OF BLOWS AND SERIOUS ACCIDENTS.** Keep to one side of the tractor when using external lift controls. **NEVER STAND** between tractor and implement - you could be hit by the implement.

Fig.8-1



## *Working in safety*

### 1-3 Replacing tractor parts

It is essential to use **genuine Landini spare parts** when repairing the tractor.

Pay particular attention to the following instructions when repairing and mounting parts and spares accessories.

**Use of spurious spares can jeopardize tractor safety.** Strictly comply with the torque wrench values given in the workshop manual and, where indicated, install the relative locking devices when demounting operations are being carried out.

Installation of spurious spare parts will automatically invalidate your tractor's warranty, since all Landini spares are guaranteed by the manufacturer. Landini dealers must only supply genuine spare parts.

### 1-4 Safe use of the tractor

Only qualified and authorized operators are able to use farming tractors in safety. To be qualified you also need to be familiar with the instructions in the operation and maintenance manual and to strictly comply with these indications.

Moreover, operators need to know the labour safety regulations.

For example, some regulations specify that no one under the age of 18 years may use a tractor.

You are responsible for knowing these regulations and for complying with them at work.

They also include the following instructions for safe use of the tractor.



**Warning: The operator must never use alcohol or drugs that can affect his attention or the co-ordination of his movements.**

#### Observe the following precautions

- Do not allow children or unauthorized persons to drive your tractor.

- Fasten your seat belt if the tractor is fitted with a roll-over frame.
- Whenever possible, do not use the tractor near ditches or embankments.
- Reduce speed when turning the tractor, crossing slopes and on rough, slippery or muddy surfaces.
- Keep clear of slopes too steep for safe operation.
- Watch where you are going - especially at row ends and around trees.
- Never let anyone else get on to the tractor or the implement.
- Operate the tractor smoothly, with no sudden movements: do not turn, start or stop abruptly.
- Hitch only to the drawbar and recommended hitch points. Never hitch above the central line of the rear axle.
- Apply the parking brake whenever the tractor is stopped.
- Never alter or remove any part of the equipment.
- Keep others well clear of your work area.
- Never use attachments that are not designed for your tractor.



## Working in safety

### Safety frame (ROPS)

#### Safety frame

Either a roll-over protective structure or a cab is mounted as standard equipment together with a safety belt. You cannot work without the safety frame or cab. A safety structure or cab reduces the risk of injury should the tractor roll over. Rolling over without a safety structure or cab can cause damage and serious injury.

#### Use

- Before using the tractor, ensure that the ROPS or the cab has not been damaged and that it is securely fastened to the tractor.
- DO NOT attach chains, cables, etc., to the ROPS or to the cab for towing purposes as this could cause the tractor to tip up: always use the drawbar for this purpose.
- Always fasten your safety belt. Do not wear the safety belt if the tractor is not equipped with a ROPS or cab.
- Check the safety belt for damage. Damaged belts must be replaced.

#### Damaged ROPS or cabs

If the tractor has rolled over and the ROPS or the cab have been damaged (e.g. in the case of a crash against a bridge), they must be replaced in order to ensure the original degree of protection.

After an accident, check the ROPS or cab, the driving seat, the safety belt and the anchor points of the safety belt. Replace all damaged parts before using the tractor again.

**DO NOT WELD, DRILL, BEND OR STRAIGHTEN THE ROPS OR CAB:** to do so reduces the degree of protection that is ensured by original equipment.

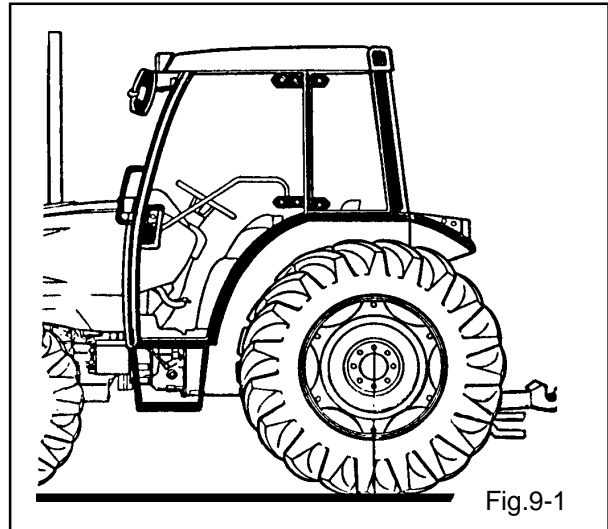







**CHAP. 1**

***Introduction to the Deltasix transmission***

**INDEX**

**Sect. 2 Introduction to the DeltaSix transmission**

2-1 Modular transmission.....	1-16
2-2 Deltasix: its target .....	1-17
2-3 Main components .....	1-18
2-4 The performances of the Deltasix transmission.....	1-19

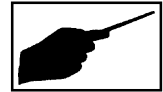

## *Introduction to the DeltaSix transmission*

### 2-1 Modular transmission



Fig. 10-1

Regardless of its power rating, the transmission of a Legend tractor can consist of several mechanical assemblies that establish its forward and reverse running options with different speed ratios.

It is the modular type and in the standard version has a gearbox with 6 synchronised speeds, three ranges (slow-normal-fast) and a synchronized reverse shuttle.



## Introduction to the DeltaSix transmission

### 2-2 Delta Six: its target

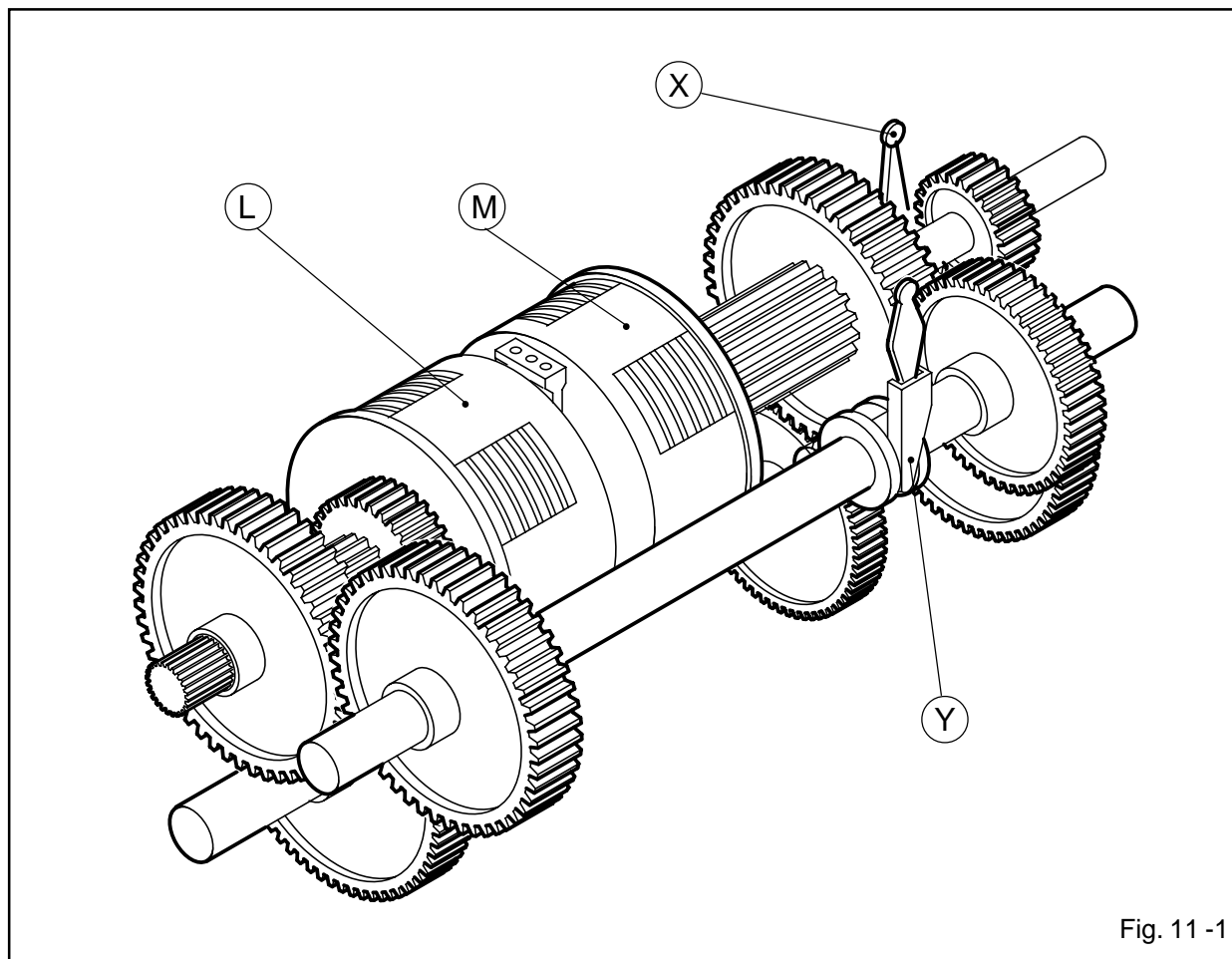

Fig. 11 -1

The DeltaSix unit installed in Legend tractors is a transmission system that varies the speed on load, with hydraulic clutches (L/M) and mechanical synchronizers (X/Y Fig. 11-1). It is mounted prior to the conventional gearbox transmission, housed in the clutch casing instead of the Power-Six unit. DeltaSix multiplies the basic speeds of the Legend tractor by three, thus obtaining a direct drive (ratio 1:1), an underdrive (ratio 1:0.834), an overdrive (ratio 1:1.213) and a reverse drive (ratio 1:1.028) for each gear (Fig. 12-1). The purpose of this unit is to offer high mechanical and hydraulic efficiency, in keeping with the high reliability standards of the Landini products.

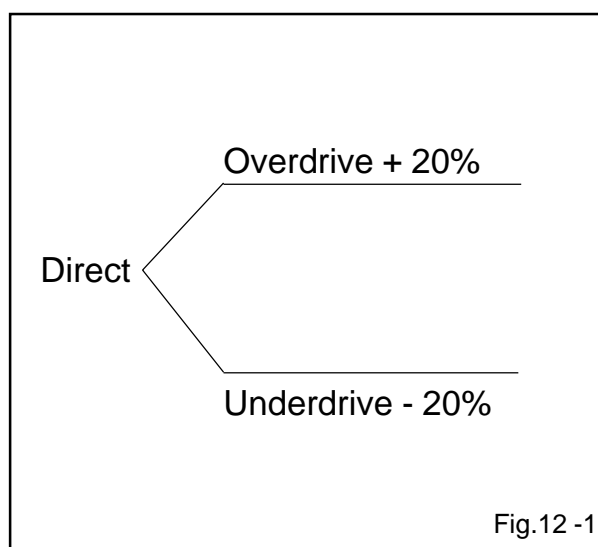

Fig.12 -1