

KUBOTA SHOP MANUAL

ENGLISH

KUBOTA DIESEL ENGINE

MODELS

**V3600-E3 · V3600-T-E3 ·
V3800-DI-T-E3 · V3300-E3BG ·
V3600-T-E3BG**

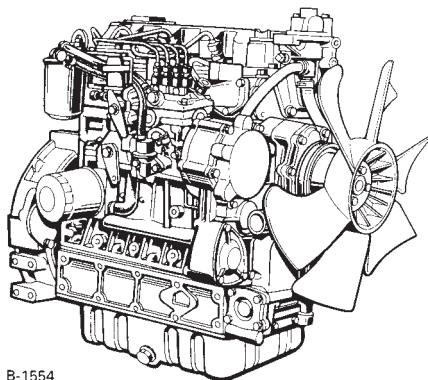

B-1554

READ AND SAVE THIS MANUAL

Kubota

TO THE READER

This Workshop Manual has been prepared to provide servicing personnel with information on the mechanism, service and maintenance of V3600-E3B, V3600-T-E3B, V3800DI-T-E3B, V3600-E3CB, V3600-T-E3CB, V3800DI-T-E3CB, V3300-E3BG, V3600-T-E3BG and V3800DI-T-E3BG. It is divided into three parts, "General", "Mechanism" and "Servicing".

■ General

Information on the engine identification, the general precautions, maintenance check list, check and maintenance and special tools are described.

■ Mechanism

Information on the construction and function are included. This part should be understood before proceeding with troubleshooting, disassembling and servicing.

Refer to Diesel Engine Mechanism Workshop Manual (Code No. 9Y021-01876) for the one which has not been described to this workshop manual.

■ Servicing

Information on the troubleshooting, servicing specification lists, tightening torque, checking and adjusting, disassembling and assembling, and servicing which cover procedures, precautions, factory specifications and allowable limits.

All information illustrations and specifications contained in this manual are based on the latest product information available at the time of publication.

The right is reserved to make changes in all information at any time without notice.

Due to covering many models of this manual, information or picture being used have not been specified as one model.

October 2007

© KUBOTA Corporation 2007



SAFETY FIRST

This symbol, the industry's "Safety Alert Symbol", is used throughout this manual and on labels on the machine itself to warn of the possibility of personal injury. Read these instructions carefully.

It is essential that you read the instructions and safety regulations before you attempt to repair or use this unit.



DANGER

: Indicates an imminently hazardous situation which, if not avoided, will result in death or serious injury.



WARNING

: Indicates a potentially hazardous situation which, if not avoided, could result in death or serious injury.



CAUTION

: Indicates a potentially hazardous situation which, if not avoided, may result in minor or moderate injury.



IMPORTANT

: Indicates that equipment or property damage could result if instructions are not followed.



NOTE

: Gives helpful information.

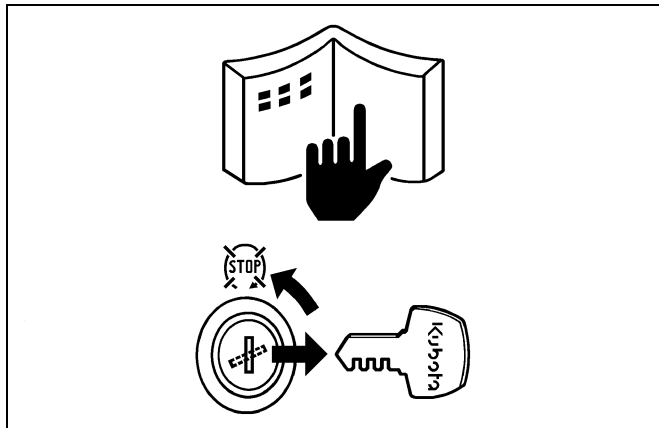

BEFORE SERVICING AND REPAIRING

- Read all instructions and safety instructions in this manual and on your engine safety decals.
- Clean the work area and engine.
- Park the machine on a firm and level ground.
- Allow the engine to cool before proceeding.
- Stop the engine, and remove the key.
- Disconnect the battery negative cable.
- Hang a "**DO NOT OPERATE**" tag in operator station.

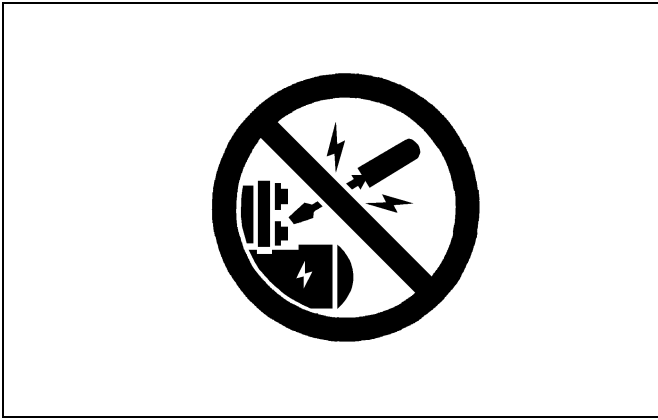

SAFETY STARTING

- Do not start the engine by shorting across starter terminals or bypassing the safety start switch.
- Unauthorized modifications to the engine may impair the function and / or safety and affect engine life.

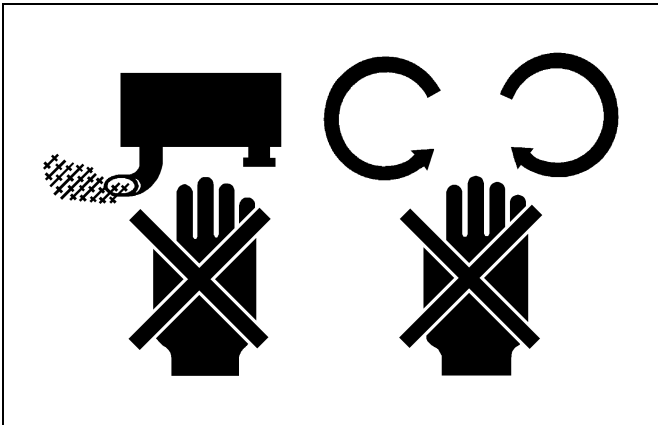

SAFETY WORKING

- Do not work on the machine while under the influence of alcohol, medication, or other substances or while fatigued.
- Wear close fitting clothing and safety equipment appropriate to the job.
- Use tools appropriate to the work. Makeshift tools, parts, and procedures are not recommended.
- When servicing is performed together by two or more persons, take care to perform all work safely.
- Do not touch the rotating or hot parts while the engine is running.
- Never remove the radiator cap while the engine is running, or immediately after stopping. Otherwise, hot water will spout out from radiator. Only remove radiator cap when cool enough to touch with bare hands. Slowly loosen the cap to first stop to relieve pressure before removing completely.
- Escaping fluid (fuel or hydraulic oil) under pressure can penetrate the skin causing serious injury. Relieve pressure before disconnecting hydraulic or fuel lines. Tighten all connections before applying pressure.
- Wear a suitable hearing protective device such as earmuffs or earplugs to protect against objectionable or uncomfortable loud noises.
- Do not open high-pressure fuel system. High-pressure fluid remaining in fuel lines can cause serious injury. Do not disconnect or attempt to repair fuel lines, sensors, or any other components between the high-pressure fuel pump and injectors on engines with high pressure common rail fuel system.
- High voltage exceeding 100 V is generated in the ECU, and is applied to the injector. Pay sufficient caution to electric shock when performing work activities.

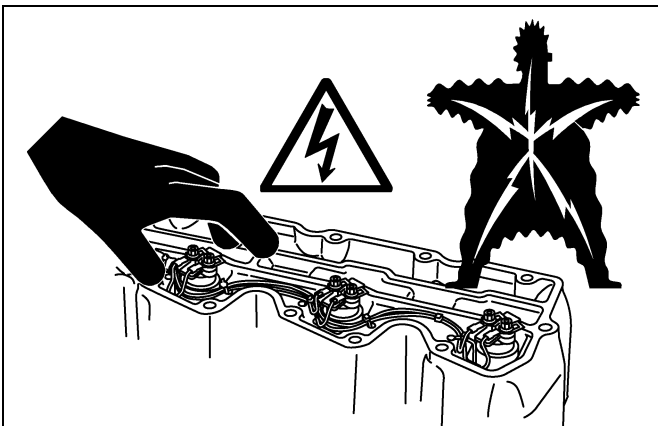
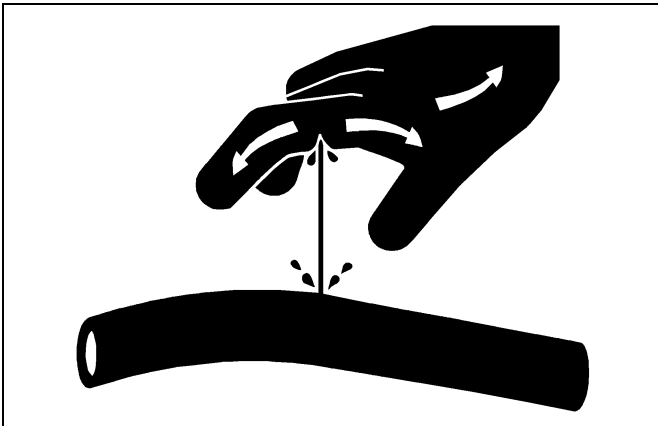

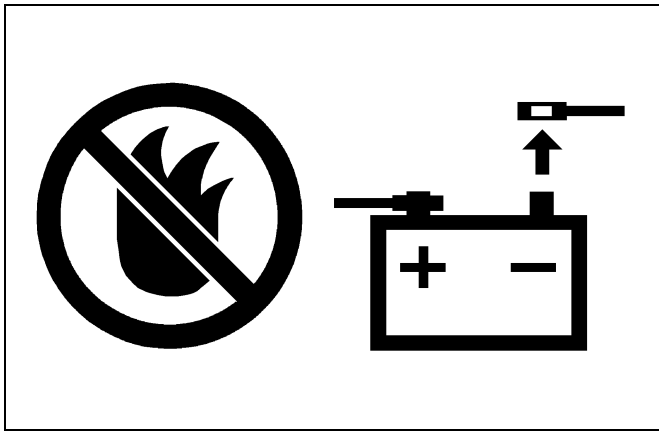

AVOID FIRES

- Fuel is extremely flammable and explosive under certain conditions. Do not smoke or allow flames or sparks in your working area.
- To avoid sparks from an accidental short circuit, always disconnect the battery negative cable first and connect it last.
- Battery gas can explode. Keep sparks and open flame away from the top of battery, especially when charging the battery.
- Make sure that no fuel has been spilled on the engine.

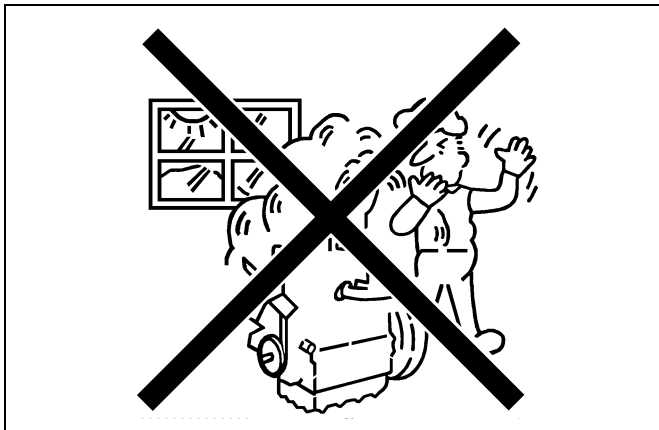

VENTILATE WORK AREA

- If the engine must be running to do some work, make sure the area is well ventilated. Never run the engine in a closed area. The exhaust gas contains poisonous carbon monoxide.

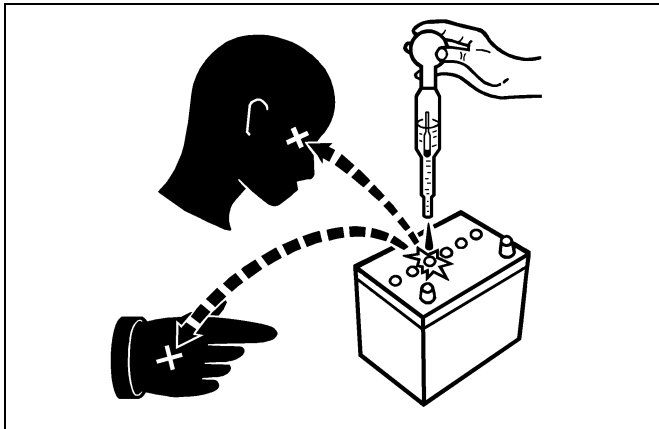

PREVENT ACID BURNS

- Sulfuric acid in battery electrolyte is poisonous. It is strong enough to burn skin, clothing and cause blindness if splashed into eyes. Keep electrolyte away from eyes, hands and clothing. If you spill electrolyte on yourself, flush with water, and get medical attention immediately.

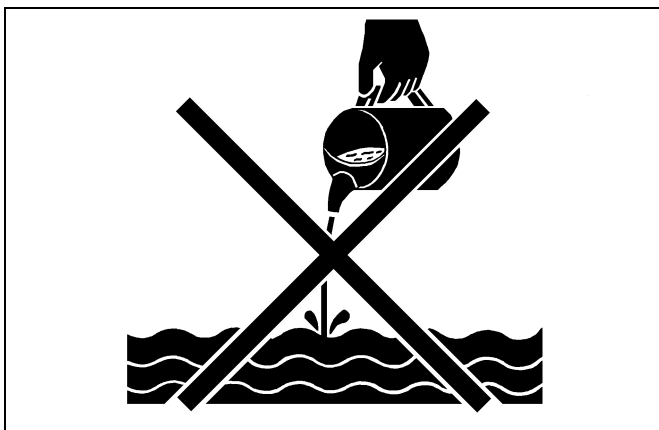

DISPOSE OF FLUIDS PROPERLY

- Do not pour fluids into the ground, down a drain, or into a stream, pond, or lake. Observe relevant environmental protection regulations when disposing of oil, fuel, coolant, electrolyte and other harmful waste.

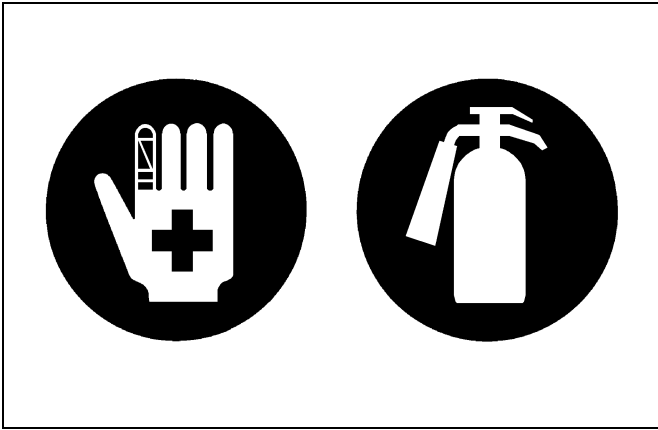
**PREPARE FOR EMERGENCIES**

- Keep a first aid kit and fire extinguisher handy at all times.
- Keep emergency numbers for doctors, ambulance service, hospital and fire department near your telephone.

SPECIFICATIONS

Model	V3600-E3B	V3600-E3CB	V3600-T-E3B	V3600-T-E3CB	V3800DI-T-E3B	V3800DI-T-E3CB
Number of Cylinder	4					
Type	Vertical, water-cooled, 4-cycle diesel engine					
Bore × Stroke	98 × 120 mm (3.86 × 4.72 in.)				100 × 120 mm (3.94 × 4.72 in.)	
Total Displacement	3620 cm ³ (220.9 cu.in.)				3769 cm ³ (230.0 cu.in.)	
ISO Net Continuous	40.2 kW / 2600 min ⁻¹ (rpm) (53.9 HP / 2600 min ⁻¹ (rpm))		51.5 kW / 2600 min ⁻¹ (rpm) (69.0 HP / 2600 min ⁻¹ (rpm))		60.9 kW / 2600 min ⁻¹ (rpm) (81.6 HP / 2600 min ⁻¹ (rpm))	
ISO / SAE Net Intermittent	46.3 kW / 2600 min ⁻¹ (rpm) (62.1 HP / 2600 min ⁻¹ (rpm))		59.3 kW / 2600 min ⁻¹ (rpm) (79.5 HP / 2600 min ⁻¹ (rpm))		70.1 kW / 2600 min ⁻¹ (rpm) (94.0 HP / 2600 min ⁻¹ (rpm))	
SAE Gross Intermittent	49.8 kW / 2600 min ⁻¹ (rpm) (66.8 HP / 2600 min ⁻¹ (rpm))		63.0 kW / 2600 min ⁻¹ (rpm) (84.5 HP / 2600 min ⁻¹ (rpm))		74.0 kW / 2600 min ⁻¹ (rpm) (99.2 HP / 2600 min ⁻¹ (rpm))	
Maximum Bare Speed	2800 min ⁻¹ (rpm)					
Minimum Bare Idling Speed	775 to 825 min ⁻¹ (rpm)					
Combustion Chamber	Spherical Type (E-TVCS)				Reentrant Type, Center Direct Injection Type (E-CDIS)	
Fuel Injection Pump	Bosch Type Mini Pump					
Governor	All speed mechanical governor					
Direction of Rotation	Counter-clockwise (Viewed from flywheel side)					
Injection Nozzle	BOSCH Throttle Type				Bosch P Type	
Injection Timing	0.14 rad (8.0 °) before T.D.C.		0.070 rad (4.0 °) before T.D.C.		0.10 rad (6.0 °) before T.D.C.	
Firing Order	1-3-4-2					
Injection Pressure	13.73 MPa (140.0 kgf/cm ² , 1991 psi)				1st stage 18.63 MPa (190.0 kgf/cm ² , 2702 psi), 2nd stage 23.54 MPa (240.0 kgf/cm ² , 3414 psi),	
Compression Ratio	22.6		21.8		19.0	
Lubricating System	Forced lubrication by trochoid pump					
Oil Pressure Indicating	Electrical Type Switch					
Lubricating Filter	Full Flow Paper Filter (Cartridge Type)					
Cooling System	Pressurized radiator, forced circulation with water pump					
Starting System	Electric Starting with Starter					
Starting Motor	12 V, 3.0 kW					
Starting Support Device	By Glow Plug in Combustion Chamber				Intake Air Heater in Intake Manifold	
EGR	NONE		Internal EGR (2 stage Exhaust Cam)		External EGR (EGR Cooler + Mechanical EGR Valve + Reed Valve)	
Battery	12 V, 136 AH equivalent					
Charging Alternator	12 V, 540 W					
Fuel	Diesel Fuel No. 2-D S500 or S15, see page G-7.					
Lubricating Oil	Class CF lubricating oil as per API classification is recommended. For details on recommended lubricating oils, see page G-7.					
Lubricating Oil Capacity	13.2 L (3.49 U.S.gals)					
Weight (Dry)	264 kg (582 lbs)	245 kg (540 lbs)	275 kg (606 lbs)	252 kg (556 lbs)	288 kg (635 lbs)	281 kg (619 lbs)

* The specification described above is of the standard engine of each model.

* Conversion Formula : HP = 0.746 kW, PS = 0.7355 kW

W1028103

Model	V3300-E3BG	V3600-T-E3BG	V3800DI-T-E3BG
Number of Cylinders	4		
Type	Vertical, Water-cooled, 4 cycle diesel engine		
Bore × Stroke	98 x 110 mm (3.86 x 4.33 in.)	98 x 120 mm (3.86 x 4.72 in.)	100 x 120 mm (3.94 x 4.72 in.)
Total Displacement	3318 cm ³ (202.48 cu.in.)	3620 cm ³ (220.9 cu.in.)	3769 cm ³ (230.0 cu.in.)
STANDBY ISO 3046 SAE J-1349	33.6 kW / 1800 min ⁻¹ (rpm) 45.0 HP / 1800 min ⁻¹ (rpm)	43.1 kW / 1800 min ⁻¹ (rpm) 57.8 HP / 1800 min ⁻¹ (rpm)	47.8 kW / 1800 min ⁻¹ (rpm) 64.1 HP / 1800 min ⁻¹ (rpm) (NET STANDBY SEA J-1995)
NET Continuous ISO 3046 SAE J-1349	30.6 kW / 1800 min ⁻¹ (rpm) 41.0 HP / 1800 min ⁻¹ (rpm)	39.2 kW / 1800 min ⁻¹ (rpm) 52.5 HP / 1800 min ⁻¹ (rpm)	43.5 kW / 1800 min ⁻¹ (rpm) 58.3 HP / 1800 min ⁻¹ (rpm) (NET Continuous SEA J-1995)
Governor Regulation	Less than 5 %		–
Combustion Chamber	Spherical type (E-TVCS)		Reentrant Type, Center Direct Injection Type (E-CDIS)
Fuel Injection Pump	Bosch Type Mini Pump		
Governor	All speed mechanical governor		Mechanical + Electronic governor
Direction of Rotation	Counter-clockwise (viewed from flywheel side)		
Injection Nozzle	Bosch Throttle Type		Bosch P Type
Injection Timing	0.16 rad (9.0 °) before T.D.C.	0.070 rad (4.0 °) before T.D.C.	0.096 rad (5.5 °) before T.D.C.
Firing Order	1-3-4-2		
Injection Pressure	13.73 MPa (140.0 kgf/cm ² , 1991 psi)		1st stage 18.63 MPa (190.0 kgf/cm ² , 2702 psi), 2nd stage 23.54 MPa (240.0 kgf/cm ² , 3414 psi),
Compression Ratio	22.6	21.8	19.0
Lubricating System	Forced lubrication by trochoid pump		
Oil Pressure Indication	Electrical type switch		
Lubricating Filter	Full flow paper filter (Cartridge type)		
Cooling System	Pressurized radiator, forced circulation with water pump		
Starting System	Electric Starting with Starter		
Starting Motor	12 V, 3.0 kW		
Starting Support Device	By glow plug in combustion chamber		Intake Air Heater in Intake Manifold
EGR	None	Internal EGR (2 stage Exhaust Cam)	External EGR (EGR Cooler + Mechanical EGR Valve + Reed Valve)
Battery	12 V, 136 AH, equivalent		
Charging Alternator	12 V, 540 W		
Fuel	Diesel Fuel No. 2-D S500 or S15, see page G-7.		
Lubricating Oil	Class CF lubricating oil as per API classification is recommended. For details on recommended lubricating oils, see page G-7.		
Lubricating Oil Capacity	13.2 L (3.49 U.S.gals)		
Weight (Dry)	281 kg (619 lbs)	284 kg (626 lbs)	280 kg (617 lbs)

* The specification described above is of the standard engine of each model.

* Conversion Formula : HP = 0.746 kW, PS = 0.7355 kW

W10455750

PERFORMANCE CURVES

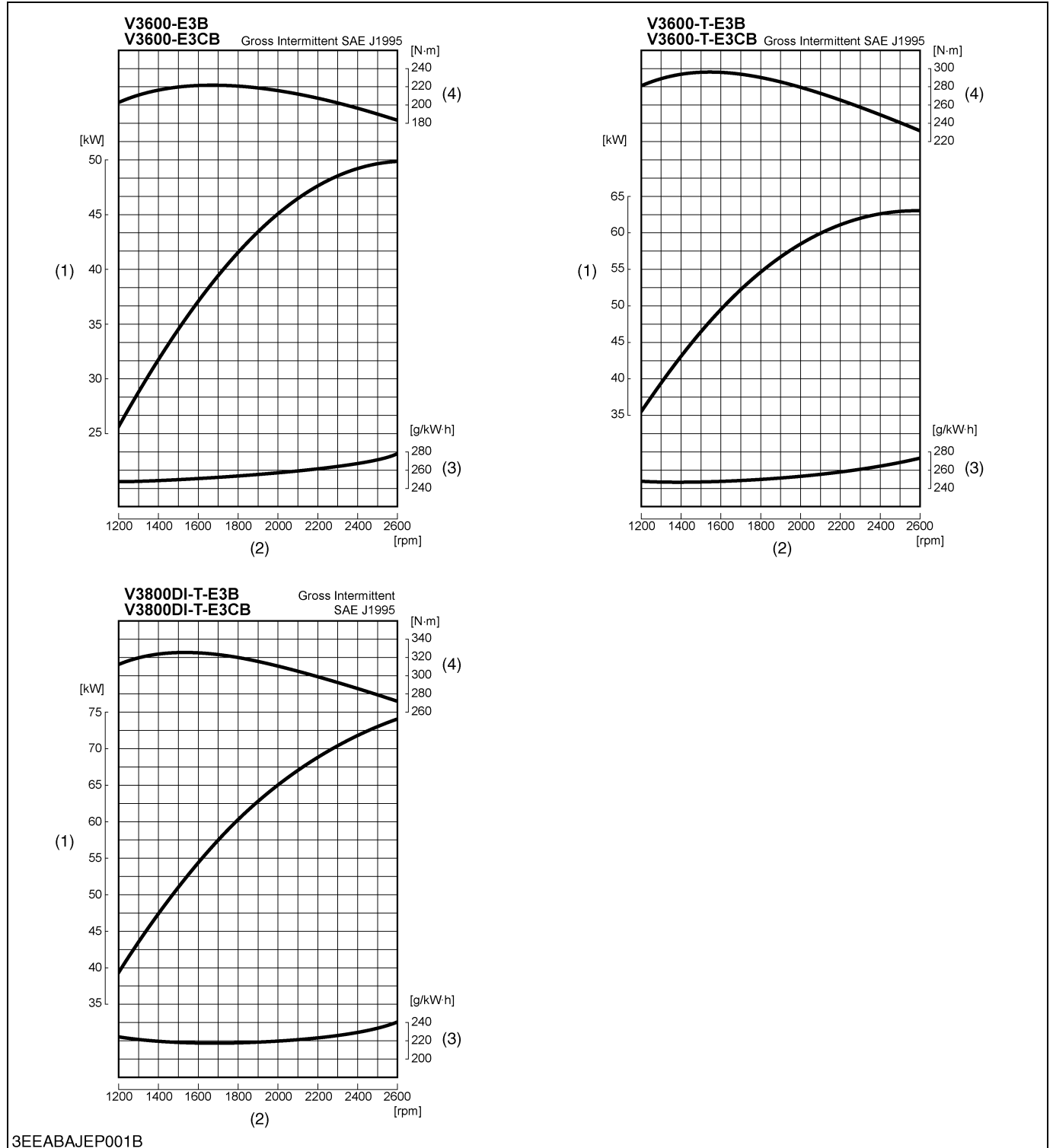

(1) Brake Horse Power

(2) Engine Speed

(3) B.S.F.C.

(4) Torque

DIMENSIONS

Unit : mm (in.)

**V3600-E3B
V3300-E3BG**

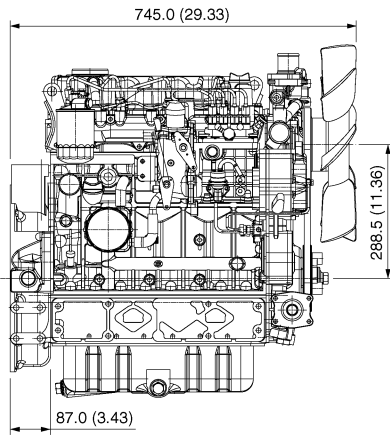

**V3600-T-E3B
V3600-T-E3BG**

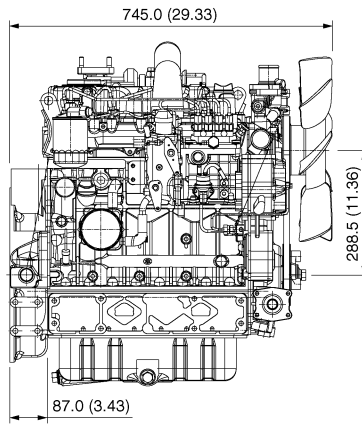

**V3800DI-T-E3B
V3800DI-T-E3BG**

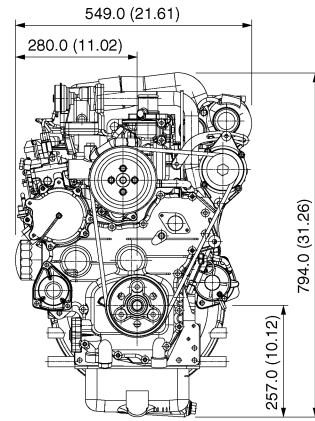
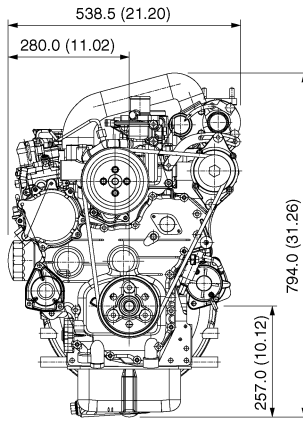
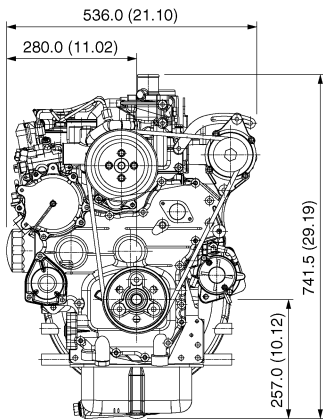
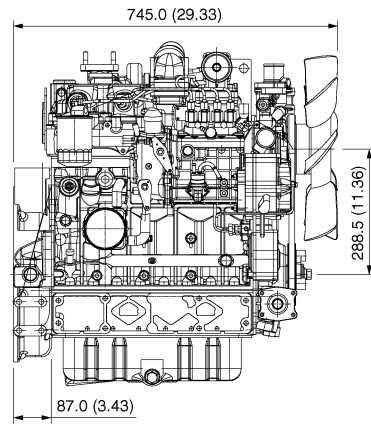

3EEABAJFP001B

Unit : mm (in.)

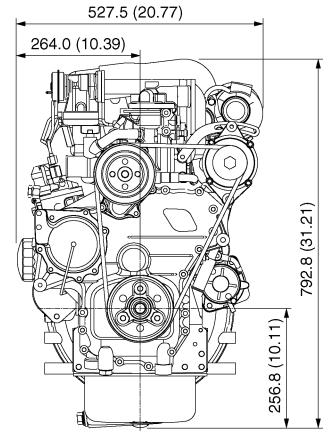
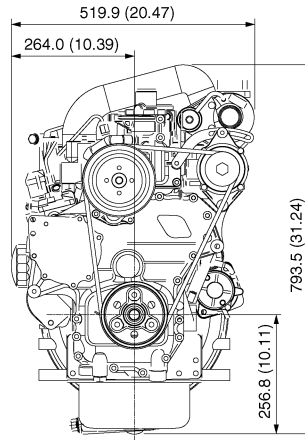
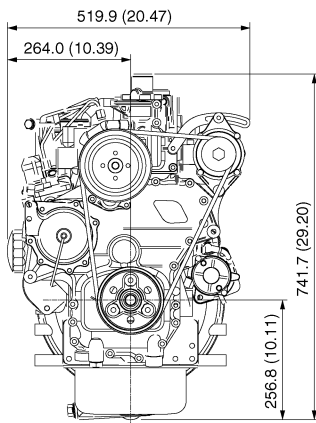
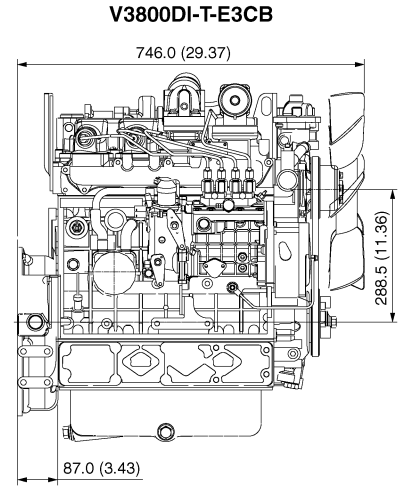
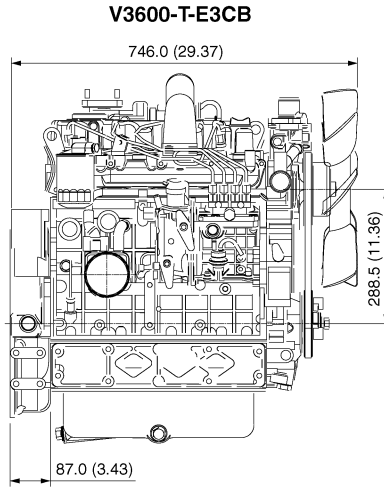
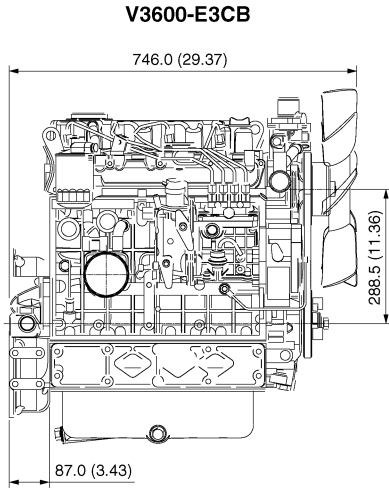

3EEABAJFP002B

GENERAL

CONTENTS

1. ENGINE IDENTIFICATION.....	G-1
[1] MODEL NAME AND ENGINE SERIAL NUMBER.....	G-1
[2] E3B ENGINE.....	G-3
[3] CYLINDER NUMBER.....	G-3
2. GENERAL PRECAUTIONS.....	G-4
3. MAINTENANCE CHECK LIST.....	G-5
4. CHECK AND MAINTENANCE.....	G-8
[1] DAILY CHECK POINTS.....	G-8
[2] CHECK POINTS OF INITIAL 50 HOURS.....	G-10
[3] CHECK POINT OF EVERY 50 HOURS.....	G-11
[4] CHECK POINTS OF EVERY 250 HOURS.....	G-12
[5] CHECK POINTS OF EVERY 500 HOURS.....	G-14
[6] CHECK POINT OF EVERY 1000 HOURS.....	G-18
[7] CHECK POINTS OF EVERY 1 OR 2 MONTHS.....	G-19
[8] CHECK POINTS OF EVERY 1500 HOURS.....	G-21
[9] CHECK POINTS OF EVERY 3000 HOURS.....	G-23
[10]CHECK POINTS OF EVERY 1 YEAR.....	G-28
[11]CHECK POINTS OF EVERY 2 YEARS.....	G-29
5. SPECIAL TOOLS.....	G-32

1. ENGINE IDENTIFICATION

[1] MODEL NAME AND ENGINE SERIAL NUMBER

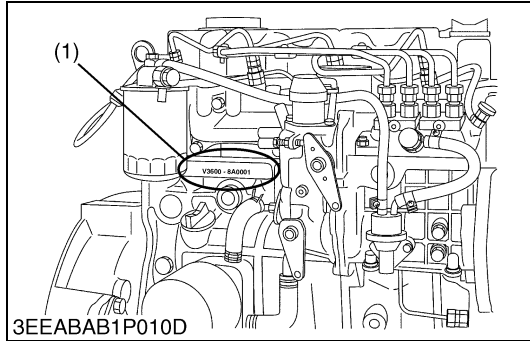

When contacting the manufacture, always specify your engine model name and serial number.

The engine model and its serial number need to be identified before the engine can be serviced or parts replaced.

■ Engine Serial Number

The engine serial number is an identified number for the engine. It is marked after the engine model number.

It indicates month and year of manufacture as follows.

• Year of manufacture

Alphabet or Number	Year	Alphabet or Number	Year
1	2001	F	2015
2	2002	G	2016
3	2003	H	2017
4	2004	J	2018
5	2005	K	2019
6	2006	L	2020
7	2007	M	2021
8	2008	N	2022
9	2009	P	2023
A	2010	R	2024
B	2011	S	2025
C	2012	T	2026
D	2013	V	2027
E	2014		

(1) Engine Model Name and Serial Number

W1010477

- **Month of manufacture**

Month	Engine Lot Number	
January	A0001 ~ A9999	B0001 ~ BZ999
February	C0001 ~ C9999	D0001 ~ DZ999
March	E0001 ~ E9999	F0001 ~ FZ999
April	G0001 ~ G9999	H0001 ~ HZ999
May	J0001 ~ J9999	K0001 ~ KZ999
June	L0001 ~ L9999	M0001 ~ MZ999
July	N0001 ~ N9999	P0001 ~ PZ999
August	Q0001 ~ Q9999	R0001 ~ RZ999
September	S0001 ~ S9999	T0001 ~ TZ999
October	U0001 ~ U9999	V0001 ~ VZ999
November	W0001 ~ W9999	X0001 ~ XZ999
December	Y0001 ~ Y9999	Z0001 ~ ZZ999

* Alphabetical letters "I" and "O" are not used.

e.g. V3600 - 8 B A001

(a) (b)(c) (d)

- (a) Engine Model Name : **V3600**
- (b) Year : **8** indicates **2008**
- (c) Month : **A** or **B** indicates **January**
- (d) Lot number : (**0001 ~ 9999** or **A001 ~ Z999**)

W1011076

[2] E3B ENGINE

[Example : Engine Model Name V3600-**E3B**-XXXX]

The emission controls previously implemented in various countries to prevent air pollution will be stepped up as Non-Road Emission Standards continue to change. The timing or applicable date of the specific Non-Road Emission regulations depends on the engine output classification.

Over the past several years, Kubota has been supplying diesel engines that comply with regulations in the respective countries affected by Non-Road Emission regulations. For Kubota Engines, E3B will be the designation that identifies engine models affected by the next emission phase (See the table below).

When servicing or repairing ###-E3B series engines, use only replacement parts for that specific E3B engine, designated by the appropriate E3B Kubota Parts List and perform all maintenance services listed in the appropriate Kubota Operator's Manual or in the appropriate E3B Kubota Workshop Manual. Use of incorrect replacement parts or replacement parts from other emission level engines (for example: E2B engines), may result in emission levels out of compliance with the original E3B design and EPA or other applicable regulations. Please refer to the emission label located on the engine head cover to identify Output classification and Emission Control Information. E3B engines are identified with "ET" at the end of the Model designation, on the US EPA label. Please note : E3B is not marked on the engine.

TYPE :	#####
FAMILY :	#####
APPROVAL NUMBER:	###/###/#####
Kubota KUBOTA Corporation	
#####	
(1)	(2)
EMISSION CONTROL INFORMATION	
THIS ENGINE MEETS 2008 ##### EMISSION REGULATIONS FOR U.S. EPA AND CALIFORNIA NONROAD CY ENGINES.	
Kubota KUBOTA Corporation	
MODEL :	### -ET #####
FAMILY :	8 ### EGS: EM
OUTPUT :	## kW / ## rpm CATEGORY: ## - ## kW
VALVE CLEARANCE (COLD) :	IN ## mm EX ## mm
INJ. TIMING :	### DEG BTDC LOW IDLE: ## - ## rpm
LOW SULFUR FUEL OR ULTRA LOW SULFUR FUEL ONLY	
CONTACT KUBOTA FOR FUEL SETTING. #####	
3EEAEAE0P002A	

Category (1)	Engine output classification	EU regulation
K	From 19 to less than 37 kW	STAGE IIIA
J	From 37 to less than 75 kW	STAGE IIIA
I	From 75 to less than 130 kW	STAGE IIIA

Category (2)	Engine output classification	EPA regulation
ET	Less than 19kW	Tier 4
	From 19 to less than 56 kW	Interim Tier 4
	From 56 to less than 75 kW	Tier 3
	From 75 to less than 130 kW	Tier 3

- (1) EU regulation engine output classification category
- (2) "E3B" engines are identified with "ET" at the end of the Model designation, on the US EPA label. "E3B" designates Tier 3 and some Interim Tier 4 / Tier 4 models, depending on engine output classification.

W1031971

[3] CYLINDER NUMBER

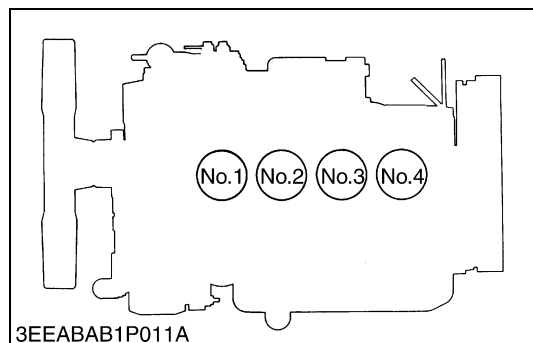

The cylinder numbers of Kubota diesel engine are designated as shown in the figure.

The sequence of cylinder numbers is given as No.1, No.2, No.3 and No.4 starting from the gear case side.

W1011077

2. GENERAL PRECAUTIONS

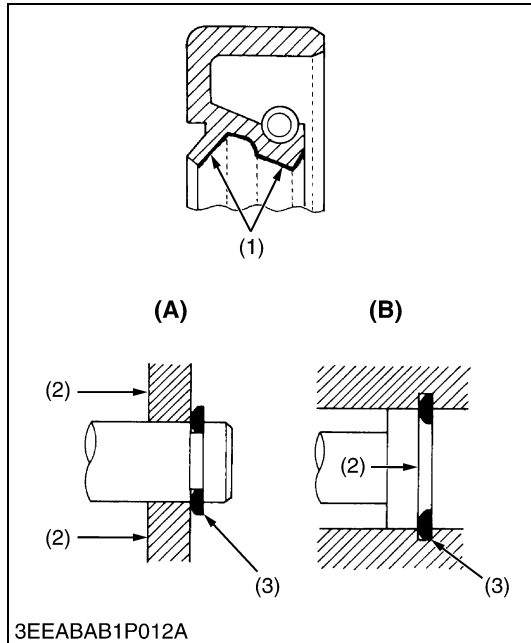

- During disassembly, carefully arrange removed parts in a clean area to prevent confusion later. Screws, bolts and nuts should be replaced in their original position to prevent reassembly errors.
- When special tools are required, use KUBOTA genuine special tools. Special tools which are not frequently used should be made according to the drawings provided.
- Before disassembling or servicing live wires, make sure to always disconnect the grounding cable from the battery first.
- Remove oil and dirt from parts before measuring.
- Use only KUBOTA genuine parts for parts replacement to maintain engine performance and to ensure safety.
- Gaskets and O-rings must be replaced during reassembly. Apply grease to new O-rings or oil seals before assembling.
- When reassembling external or internal snap rings, position them so that the sharp edge faces against the direction from which force is applied.
- Be sure to perform run-in the serviced or reassembled engine. Do not attempt to give heavy load at once, or serious damage may result to the engine.

(1) Grease

(2) Force

(3) Place the Sharp Edge against the Direction of Force

(A) External Snap Ring

(B) Internal Snap Ring

W1011734

3. MAINTENANCE CHECK LIST

To maintain long-lasting and safe engine performance, make it a rule to carry out regular inspections by following the table below.

[V3600-E3B, V3600-T-E3B, V3600-E3CB, V3600-T-E3CB, V3300-E3BG, V3600-T-E3BG]

Item	Service Interval									
	Initial 50 hrs	Every 50 hrs	Every 250 hrs	Every 500 hrs	Every 1000 hrs	Every 1 or 2 months	Every 1500 hrs	Every 3000 hrs	Every 1 year	Every 2 years
Changing engine oil	☆		☆						☆	
Replacing oil filter cartridge	☆			☆						
*Checking fuel hoses and clamps		☆								
*Cleaning air filter element (Replace the element after 6 times cleanings)			☆							
*Cleaning fuel filter			☆							
Checking battery electrolyte level			☆							
Checking radiator hoses and clamps			☆							
*Checking intake air line			☆							
Checking fan belt tension and damage	☆		☆							
*Replacing fuel filter cartridge				☆						
Replacing fan belt				☆						☆
Cleaning radiator interior				☆						
Checking valve clearance					☆					
Recharging battery						☆				
*Checking injection nozzle condition							☆			
*Checking turbocharger								☆		
Checking fuel injection pump								☆		
*Checking injection timing (spill timing)								☆		
*Replacing air filter element									☆	
Changing radiator coolant (L.L.C.)										☆
Replacing radiator hoses and clamps										☆
*Replacing fuel hoses and clamps										☆
*Replacing intake air line										☆
Replacing battery										☆

* The items listed above (* marked) are registered as emission related critical parts by KUBOTA in the U.S.EPA nonroad emission regulation.

As the engine owner, you are responsible for the performance of the required maintenance on the engine according to the above instruction.

W1029462

[V3800DI-T-E3B, V3800DI-T-E3CB, V3800DI-T-E3BG]

Item	Service Interval									
	Initial 50 hrs	Every 50 hrs	Every 250 hrs	Every 500 hrs	Every 1000 hrs	Every 1 or 2 months	Every 1500 hrs	Every 3000 hrs	Every 1 year	Every 2 years
Changing engine oil	☆			☆					☆	
Replacing oil filter cartridge	☆			☆						
*Checking fuel hoses and clamps		☆								
*Cleaning air filter element (Replace the element after 6 times cleanings)			☆							
*Cleaning fuel filter			☆							
Checking battery electrolyte level			☆							
Checking radiator hoses and clamps			☆							
*Checking intake air line			☆							
Checking fan belt tension and damage	☆		☆							
*Replacing fuel filter cartridge				☆						
Replacing fan belt				☆						☆
Cleaning radiator interior				☆						
Checking valve clearance					☆					
Recharging battery						☆				
*Checking injection nozzle condition							☆			
*Checking turbocharger								☆		
Checking fuel injection pump								☆		
*Checking injection timing (spill timing)								☆		
*Replacing air filter element									☆	
Changing radiator coolant (L.L.C.)										☆
Replacing radiator hoses and clamps										☆
*Replacing fuel hoses and clamps										☆
*Replacing intake air line										☆
Replacing battery										☆

* The items listed above (* marked) are registered as emission related critical parts by KUBOTA in the U.S.EPA nonroad emission regulation.

As the engine owner, you are responsible for the performance of the required maintenance on the engine according to the above instruction.

W1026550

■ NOTE

Engine Oil :

- Refer to the following table for the suitable American Petroleum Institute (API) classification of engine oil according to the engine type (with internal EGR, external EGR or non-EGR) and the Fuel Type Used : (Low Sulfur, Ultra Low Sulfur or High Sulfur Fuels).

Fuel Type	Engine oil classification (API classification)	
	Engines with non-EGR Engines with internal EGR	Engines with external EGR
High Sulfur Fuel [0.05 % (500 ppm) ≤ Sulfur Content < 0.50 % (5000 ppm)]	CF (If the "CF-4, CG-4, CH-4, or CI-4" engine oil is used with a high-sulfur fuel, change the engine oil at shorter intervals. (approximately half))	–
Low Sulfur Fuel [Sulfur Content < 0.05 % (500 ppm)] or Ultra Low Sulfur Fuel [Sulfur Content < 0.0015 % (15 ppm)]	CF, CF-4, CG-4, CH-4 or CI-4	CF or CI-4 (Class CF-4, CG-4 and CH-4 engine oils cannot be used on EGR type engines.)

EGR : Exhaust Gas Re-circulation

W1024941

- CJ4 classification oil is intended for use in engines equipped with DPF (Diesel Particulate Filter) and is Not Recommended for use in Kubota E3 specification engines.**
- Oil used in the engine should have API classification and Proper SAE Engine Oil Viscosity according to the ambient temperatures where the engine is operated.**
- With strict emission control regulations now in effect, the CF-4 and CG-4 engine oils have been developed for use with low sulfur fuels, for On-Highway vehicle engines. When a Non-Road engine runs on high sulfur fuel, it is advisable to use a "CF or better" classification engine oil with a high Total Base Number (a minimum TBN of 10 is recommended).**

Fuel :

- Cetane Rating : The minimum recommended Fuel Cetane Rating is 45. A cetane rating greater than 50 is preferred, especially for ambient temperatures below –20 °C (–4 °F) or elevations above 1500 m (5000 ft).**
- Diesel Fuel Specification Type and Sulfur Content % (ppm) used, must be compliant with all applicable emission regulations for the area in which the engine is operated.**
- Use of diesel fuel with sulfur content less than 0.10 % (1000 ppm) is strongly recommended.**
- If high-sulfur fuel (sulfur content 0.50 % (5000 ppm) to 1.0 % (10000 ppm)) is used as a diesel fuel, change the engine oil and oil filter at shorter intervals. (approximately half)**
- DO NOT USE Fuels that have sulfur content greater than 1.0 % (10000 ppm).**
- Diesel fuels specified to EN 590 or ASTM D975 are recommended.**
- No.2-D is a distillate fuel of lower volatility for engines in industrial and heavy mobile service. (SAE J313 JUN87)**
- Since KUBOTA diesel engines of less than 56 kW (75 hp) utilize EPA Tier 4 and Interim Tier 4 standards, the use of low sulfur fuel or ultra low sulfur fuel is mandatory for these engines, when operated in US EPA regulated areas. Therefore, please use No.2-D S500 or S15 diesel fuel as an alternative to No.2-D, and use No.1-D S500 or S15 diesel fuel as an alternative to No.1-D for ambient temperatures below –10 °C (14 °F).**

1) SAE : Society of Automotive Engineers

2) EN : European Norm

3) ASTM : American Society of Testing and Materials

4) US EPA : United States Environmental Protection Agency

5) No.1-D or No.2-D, S500 : Low Sulfur Diesel (LSD) less than 500 ppm or 0.05 wt. %

No.1-D or No.2-D, S15 : Ultra Low Sulfur Diesel (ULSD) 15 ppm or 0.0015 wt. %

4. CHECK AND MAINTENANCE

[1] DAILY CHECK POINTS

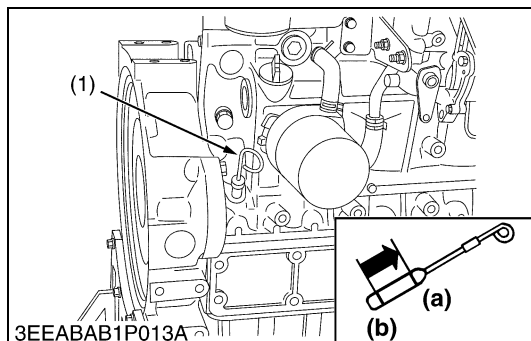

Checking Engine Oil Level

1. Level the engine.
2. To check the oil level, draw out the dipstick (1), wipe it clean, reinsert it, and draw it out again.
Check to see that the oil level lies between the two notches.
3. If the level is too low, add new oil to the specified level.

■ IMPORTANT

- When using an oil of different maker or viscosity from the previous one, drain old oil. Never mix two different types of oil.

■ NOTE

- Be sure to inspect the engine, locating it on a horizontal place. If placed on gradients, accurately, oil quantity may not be measured.
- Be sure to keep the oil level between upper and lower limits of the dipstick. Too much oil may cause a drop in output or excessive blow-by gas. On the closed breather type engine in which mist is sucked through port, too much oil may caused oil hammer. While too little oil, may seize the engine's rotating and sliding parts.

(1) Dipstick

(a) Maximum

(b) Minimum

W1035676