

Instructions for Parts Books

The heading at the top of the page will be the same for the picture of the parts at it is for the page with the part numbers.

Definition of column headings on part number pages:

REF.No → The number referring to the part on the picture page of the parts book.

Part No. → The number assigned to this part at the time of printing the parts book.

Description → Discription of part.

Q'ty → Quantity of part used on that page.

S.No. → Serial number range of the equipment that this part will fit.

>= Your serial number should be greater than or equal to the number shown.

<= Your serial number should be lesser than or equal to the serial number shown.

I/C → Interchangeability of part shown.

↔ The part shown will work for the older and later serial number.

The part shown is not interchangeable with the other serial number.

← new for old

→ old for new

Remarks → Notes about this particulart part. Sometimes this may say except [FR] or [CA]

Note about Country Codes:

The parts books we use in the United States of America may also contain information about a part that would be different in another country. It is important that you are aware of the country codes in some instances.

Symbol	Country
A	United States of America
CA	Canada
FR	France
GR	Greece
PO	Portugal
AU	Australia

If the remarks column says for example EXCEPT [FR] this part works in all countries except France. That means it will work here in the USA.

ALL PRODUCT INDEX
KX91-3

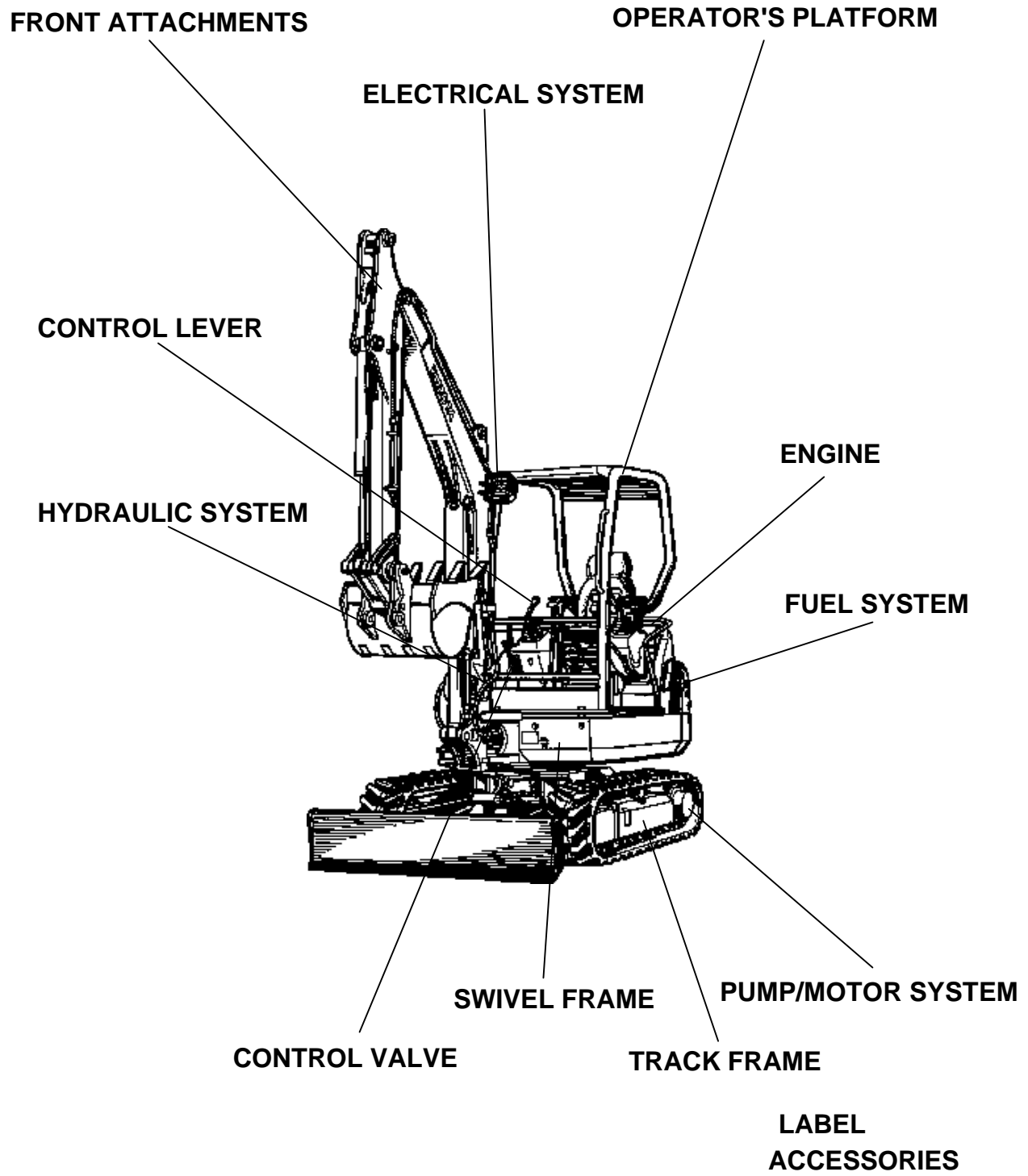

Item	Part No.	Description	Book	
ENGINE	010001	CRANK CASE	100A0180	
	010002	OIL PAN	100A0180	
	010003	CYLINDER HEAD	100A0180	
	010004	GEAR CASE	100A0180	
	010005	HEAD COVER	100A0180	
	010100	MAIN BEARING CASE	100A0180	
	010101	CAMSHAFT AND IDLE GEAR SHAFT	100A0180	
	010102	PISTON AND CRANKSHAFT	100A0180	
	010103	FLYWHEEL	100A0180	
	010105	FUEL CAMSHAFT AND GOVERNOR SHAFT	100A0180	
	010200	ENGINE STOP LEVER	100A0180	
	010202	INJECTION PUMP	100A0180	
	010203	INJECTION PUMP (COMPONENT PARTS)	100A0180	
	010204	GOVERNOR	100A0180	
	010205	SPEED CONTROL PLATE	100A0180	
	010206	NOZZLE HOLDER AND GLOW PLUG	100A0180	
	010413	ALTERNATOR	100A0180	
	010414	ALTERNATOR (COMPONENT PARTS)	100A0180	
	010416	STARTER	100A0180	
	010417	STARTER (COMPONENT PARTS)	100A0180	
	010500	WATER FLANGE AND THERMOSTAT	100A0180	
	010501	WATER PUMP	100A0180	
	010600	VALVE AND ROCKER ARM	100A0180	
	010610	INLET MANIFOLD	100A0180	
	010612	EXHAUST MANIFOLD	100A0180	
	020030	ENGINE BRACKET	100A0180	
	020511	RADIATOR	100A0180	
	020513	WATER PIPE	100A0180	
	020614	AIR CLEANER	100A0180	
	020616	MUFFLER	100A0180	
	FUEL SYSTEM	02A200	ACCEL LEVER	100A0180
		02A300	FUEL PIPING	100A0180
		02A301	FUEL FILTER (COMPONENT PARTS)	100A0180
	ELECTRICAL SYSTEM	02A303	FUEL TANK	100A0180
02B400		BATTERY	100A0180	
02B402		TIMER AND HORN	100A0180	
02B404		SWITCH AND METER	100A0180	
PUMP/MOTOR SYSTEM	02B406	LIGHT	100A0180	
	02B408	ELECTRICAL WIRING	100A0180	
	02C000	PUMP HOUSING	100A0180	
	02C200	PISTON PUMP(COMPONENT PARTS)	100A0180	
	02C30001	DRIVE MOTOR AND COMPONENT PARTS	100A0180	
	02C30002	DRIVE MOTOR AND COMPONENT PARTS	100A0180	
	02C40001	SWIVEL MOTOR AND COMPONENT PARTS	100A0180	
	02C40002	SWIVEL MOTOR AND COMPONENT PARTS	100A0180	
CONTROL VALVE	02C500	ROTARY JOINT	100A0180	
	02C502	OIL TANK	100A0180	
	02C600	CONTROL VALVE	100A0180	
	02C601	CONTROL VALVE (COMPONENT PARTS)	100A0180	
	02C60201	SPOOL SECTION (SWIVEL)	100A0180	
	02C60202	SPOOL SECTION (SWING)	100A0180	
	02C60203	SPOOL SECTION (BLADE)	100A0180	
	02C60204	SPOOL SECTION (TRAVEL STRAIGHT)	100A0180	
	02C60205	SPOOL SECTION (S/P)	100A0180	
	02C60206	SPOOL SECTION (ARM)	100A0180	
	02C60207	SPOOL SECTION (TRAVEL LH)	100A0180	
02C60208	SPOOL SECTION (TRAVEL RH)	100A0180		
02C60209	SPOOL SECTION (BOOM)	100A0180		
02C60210	SPOOL SECTION (BOOM LOCK)	100A0180		

Item	Part No.	Description	Book	
CONTROL VALVE	02C60211	SPOOL SECTION (BUCKET)	100A0180	
	02C704	CHANGE VALVE	100A0180	
	02C705	CHANGE VALVE (COMPONENT PARTS)	100A0180	
CONTROL LEVER	02C900	TPSS VALVE	100A0180	
	02C901	TPSS VALVE (COMPONENT PARTS)	100A0180	
	02D100	CONTROL LEVER (LEVER LH)	100A0180	
	02D200	CONTROL LEVER (LEVER RH)	100A0180	
	02D201	PILOT VALVE (COMPONENT PARTS)	100A0180	
	02D300	CONTROL LEVER (TRAVEL LH 1)	100A0180	
	02D301	CONTROL LEVER (TRAVEL LH 2)	100A0180	
	02D400	CONTROL LEVER (TRAVEL RH 1)	100A0180	
	02D401	CONTROL LEVER (TRAVEL RH 2)	100A0180	
	02D405	CONTROL LEVER (TRAVEL LOCK)	100A0180	
	02D500	CONTROL TRAVEL PEDAL	100A0180	
	02D600	CONTROL LEVER (SAFETY LOCK LEVER)	100A0180	
	02D700	CONTROL PEDAL (SWIVEL/SWING CHANGE 1)	100A0180	
	02D702	CONTROL PEDAL (SWIVEL/SWING CHANGE 2)	100A0180	
	02D705	TPSS LEVER	100A0180	
	02D800	CONTROL LEVER (BLADE)	100A0180	
	02D900	CONTROL LEVER (S/P)	100A0180	
HYDRAULIC SYSTEM	02E000	OIL PIPING (SUCTION)	100A0180	
	02E002	OIL PIPING (DELIVERY)	100A0180	
	02E00401	OIL PIPING (RETURN 1)	100A0180	
	02E00402	OIL PIPING (RETURN 2)	100A0180	
	02E006	OIL PIPING (OIL COOLER)	100A0180	
	02E100	OIL PIPING (CONTROL LH)	100A0180	
	02E102	OIL PIPING (CONTROL RH)	100A0180	
	02E200	OIL PIPING (TRAVEL LH)	100A0180	
	02E202	OIL PIPING (TRAVEL RH)	100A0180	
	02E204	OIL PIPING (SWIVEL)	100A0180	
	02E300	OIL PIPING (SWING)	100A0180	
	02E304	OIL PIPING (BOOM)	100A0180	
	02E400	OIL PIPING (ARM)	100A0180	
	02E500	OIL PIPING (BUCKET)	100A0180	
	02E600	OIL PIPING (BLADE)	100A0180	
	02E700	OIL PIPING (CLAMP)	100A0180	
	02E800	OIL PIPING (S/P)	100A0180	
	02F000	BOOM CYLINDER AND COMPONENT PARTS	100A0180	
	02F00001	BOOM CYLINDER AND COMPONENT PARTS	100A0180	
	02F100	ARM CYLINDER AND COMPONENT PARTS	100A0180	
	02F20001	BUCKET CYLINDER AND COMPONENT PARTS	100A0180	
	02F20002	BUCKET CYLINDER AND COMPONENT PARTS (TELESCOPIC)	100A0180	
	02F300	BLADE CYLINDER AND COMPONENT PARTS	100A0180	
	02F400	SWING CYLINDER AND COMPONENT PARTS	100A0180	
	FRONT ATTACHMENTS	02G000	SWING BRACKET	100A0180
		02G100	BOOM	100A0180
		02G104	CYLINDER COVER (BOOM)	100A0180
02G200		ARM	100A0180	
02G201		ARM (TELESCOPIC)	100A0180	
02G202		TELESCOPIC CYLINDER (TELESCOPIC)	100A0180	
02G300		BUCKET LINK	100A0180	
02G301		BUCKET LINK (TELESCOPIC)	100A0180	
02G500		BLADE	100A0180	
TRACK FRAME		02H000	TRACK FRAME	100A0180
	02H100	IDLER	100A0180	
	02H200	TRACK ROLLER	100A0180	
SWIVEL FRAME	02H300	CRAWLER	100A0180	
	02J000	SWIVEL FRAME	100A0180	

Item	Part No.	Description	Book
SWIVEL FRAME	02J001	ARCH FRAME	100A0180
	02J100	SWIVEL BEARING	100A0180
	02J200	SEAT SUPPORT	100A0180
	02J300	STEP	100A0180
	02K000	COVER LH	100A0180
	02K001	COVER RH	100A0180
	02K101	BONNET LH	100A0180
	02K102	BONNET RH	100A0180
	02K103	BONNET REAR	100A0180
	02K200	SPONGE 1	100A0180
	02K201	SPONGE 2	100A0180
	02K300	WEIGHT	100A0180
	02K400	SEAT	100A0180
	02K401	SEAT (COMPONENT PARTS)	100A0180
OPERATOR'S PLATFORM	02L000	CANOPY	100A0180
	02L100	CABIN (BODY)	100A0180
	02L200	CABIN (DOOR)	100A0180
	02L201	CABIN (DOOR LOCK)	100A0180
	02L300	CABIN (WINDOW)	100A0180
	02L301	CABIN (WINDOW FRONT)	100A0180
	02L402	CABIN (SEAL RUBBER)	100A0180
	02L500	CABIN (WIPER MOTOR)	100A0180
	02L502	CABIN (ELECTRICAL WIRING)	100A0180
	02L600	CABIN (HEATER)	100A0180
LABEL ACCESSORIES	02L601	CABIN (DEFROSTER)	100A0180
	02M000	LABEL	100A0180
	02N000	ACCESSORIES	100A0180

CRANK CASE

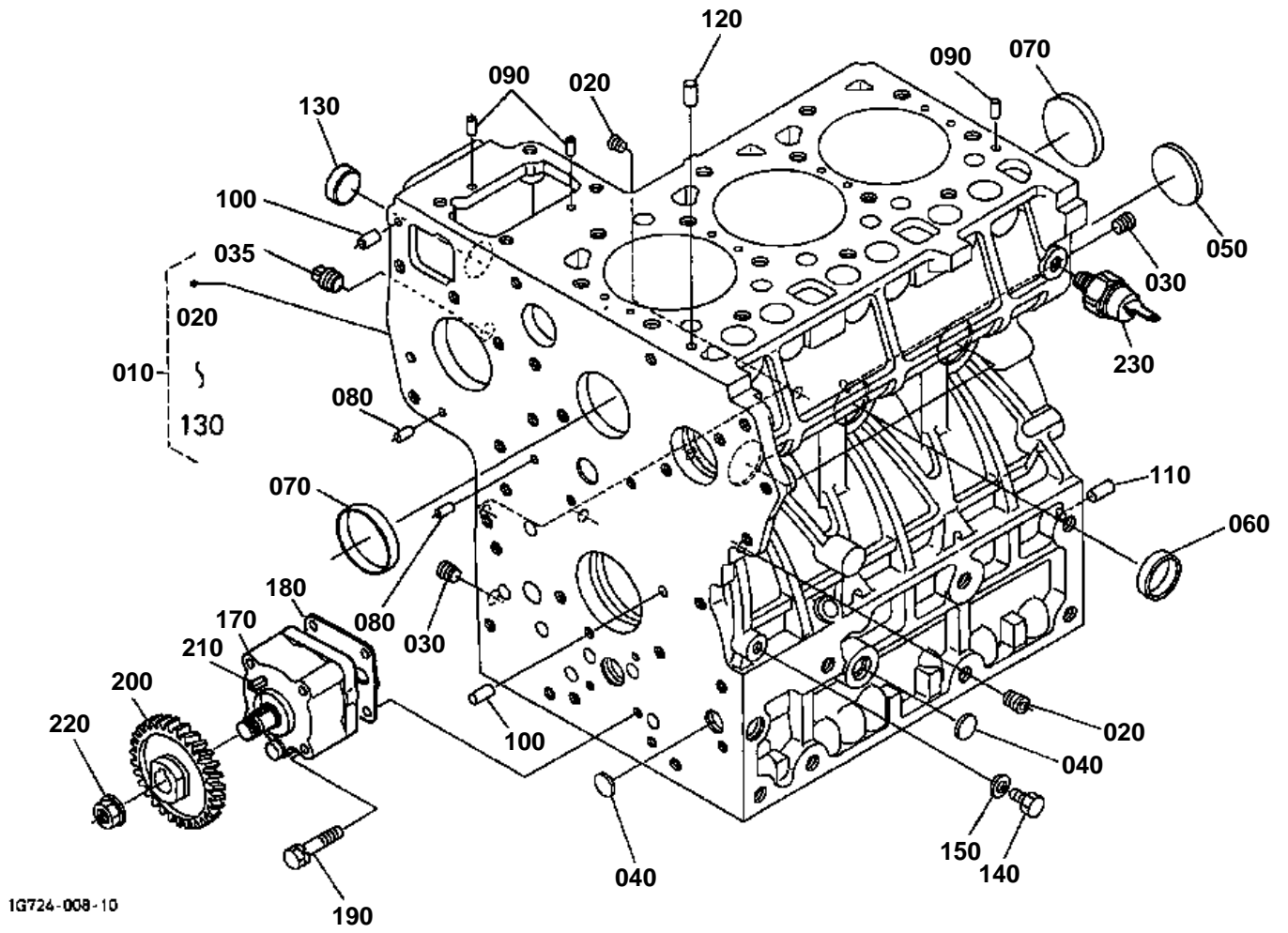

1G724-008-10



CRANK CASE

↔ Interchangeable; ≠ not interchangeable; ← new for old; → old for new

REF.No	Part No.	Description	Q'ty	S.No.	I/C	REMARKS	Weight (kgf)	Weight (lb)
010	1A053-01010	COMP.CRANKCASE	1	<=1W1403			48.5	106.7
010	1A053-01016	COMP.CRANKCASE	1	>=1Y0001	←		48.5	106.7
020	15521-96020	PLUG	5				0.003	0.0066
030	15521-96030	PLUG	2				0.007	0.0154
035	06312-10020	PLUG	1				0.016	0.0352
040	17391-96160	PLUG EXPANSION	3				0.003	0.0066
050	06311-75045	PLUG EXPANSION	1	<=3G0964			0.026	0.0572
050	16271-96160	PLUG EXPANSION	1	>=3J0001	≠		0.025	0.055
060	15221-03380	CAP SEALING	5				0.017	0.0374
070	15221-03390	CAP SEALING	2				0.03	0.066
080	05012-00408	PIN STRAIGHT	2				0.001	0.0022
090	05012-00609	PIN STRAIGHT	3				0.003	0.0066
100	05012-00612	PIN STRAIGHT	2				0.003	0.0066
110	05012-01018	PIN STRAIGHT	2				0.012	0.0264
120	15221-33650	PIN PIPE	1				0.004	0.0088
130	06311-85020	CAP SEALING	1				0.002	0.0044
140	15221-33610	PLUG	1				0.009	0.0198
150	15021-33660	GASKET	1				0.001	0.0022
160	99999-99999	BLANK	0				0	0
170	15471-35012	ASSY PUMP OIL	1				0.55	1.21
180	1A021-35150	GASKET OIL PUMP	1				0.001	0.0022
190	01023-60650	BOLT	4				0.015	0.033
200	19202-35660	GEAR OIL PUMP DRIVE	1				0.23	0.506
210	05712-00410	KEY FEATHER	1				0.001	0.0022
220	15221-35682	NUT FLANGE	1				0.014	0.0308
230	15531-39010	SWITCH OIL	1	<=20402		EXCAVATOR SERIAL No.	0.032	0.0704
230	1A024-39010	SWITCH OIL	1	>=20403	←	EXCAVATOR SERIAL No.	0.035	0.077

OIL PAN

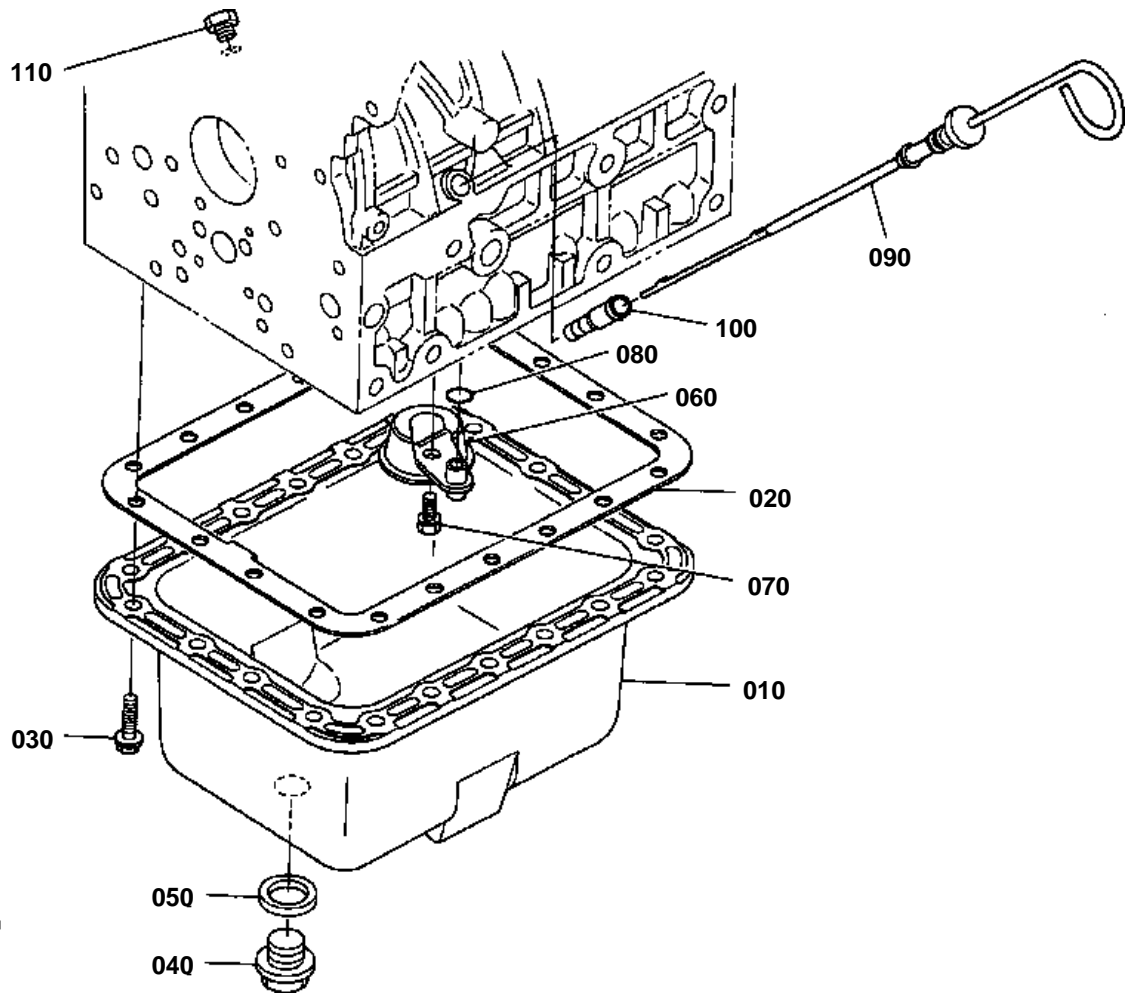

1G724-009-10



OIL PAN

↔ Interchangeable; ≠ not interchangeable; ← new for old; → old for new

REF.No	Part No.	Description	Q'ty	S.No.	I/C	REMARKS	Weight (kgf)	Weight (lb)
010	1A053-01500	COMP.OIL PAN	1				1.925	4.235
020	15313-01620	GASKET OIL PAN	1	<=2V9999			0.055	0.121
020	1G841-01620	GASKET OIL PAN	1	>=2W0001	↔		0.045	0.099
030	17333-91010	BOLT FLANGE	20	<=2V9999			0.03	0.066
030	17333-91013	BOLT FLANGE	20	>=2W0001	≠		0.03	0.066
040	15707-33750	PLUG DRAIN	1				0.1	0.22
050	15451-96670	GASKET	1				0.003	0.0066
060	16413-32110	FILTER OIL	1	<=3C9999			0.24	0.528
060	1G850-32110	FILTER OIL	1	>=3E0001	←		0.255	0.561
070	01123-60814	BOLT	1				0.01	0.022
080	04814-00160	O RING	1				0.001	0.0022
090	1A053-36410	GAUGE OIL	1				0.045	0.099
100	17456-36420	GUIDE OIL GAUGE	1				0.03	0.066
110	16414-33640	PLUG OIL GAUGE	1				0.003	0.0066

CYLINDER HEAD

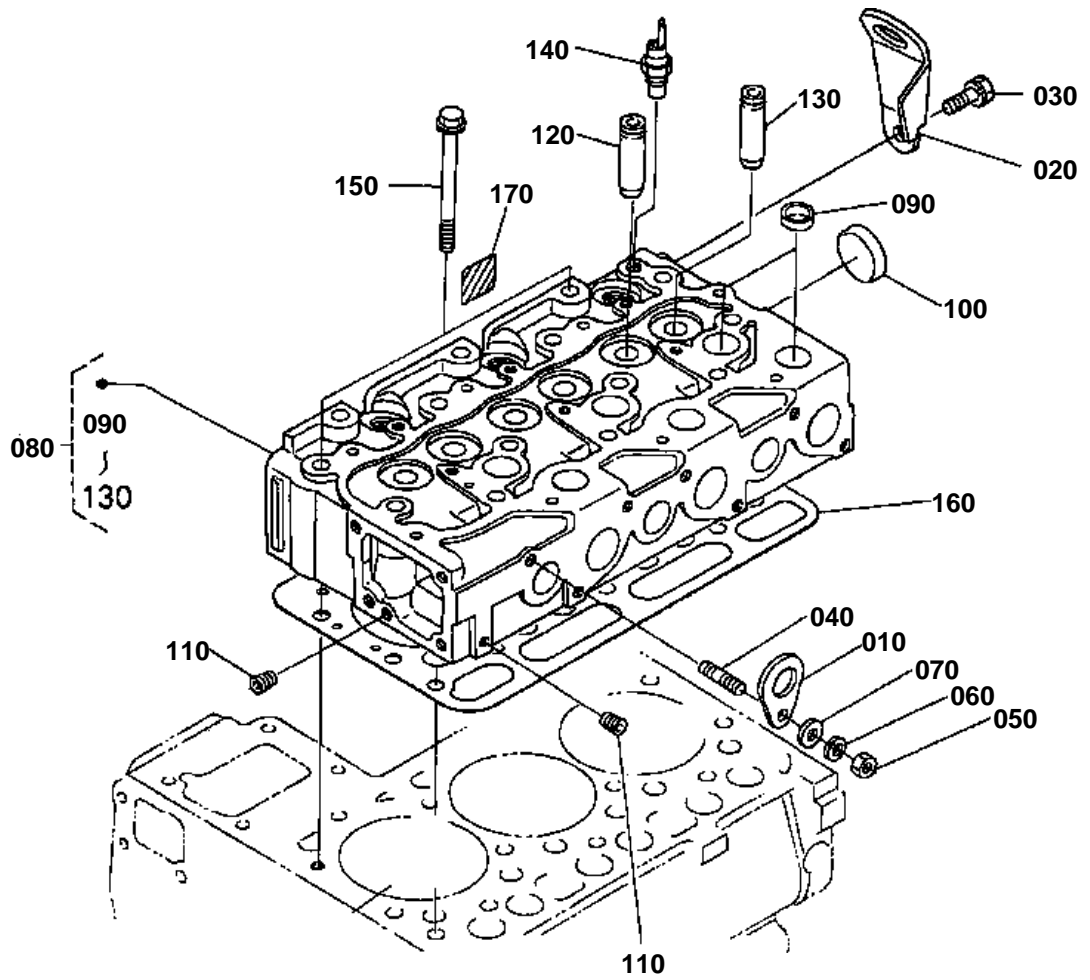

1G724-001-11



CYLINDER HEAD

↔ Interchangeable; ≠ not interchangeable; ← new for old; → old for new

REF.No	Part No.	Description	Q'ty	S.No.	I/C	REMARKS	Weight (kgf)	Weight (lb)
010	15221-01750	HOOK ENGINE	1				0.04	0.088
020	16415-01752	HOOK ENGINE	1				0.115	0.253
030	01123-60816	BOLT	1				0.01	0.022
040	15471-91530	STUD	1				0.01	0.022
050	02156-50080	NUT	1				0.004	0.0088
060	04512-60080	WASHER SPRING	1				0.002	0.0044
070	04012-50080	WASHER PLAIN	1				0.001	0.0022
080	1A051-03043	COMP.CYLINDER HEAD	1	<=2B9999			0	0
080	1A051-03044	COMP.CYLINDER HEAD	1	>=2C0001	←		15	33
080	1A013-03043	COMP.CYLINDER HEAD	1	>=2J0001	≠		15	33
090	15221-03370	CAP SEALING	9				0.01	0.022
100	15221-03490	CAP SEALING	1				0.02	0.044
110	15261-96010	PLUG	2				0.002	0.0044
120	17321-13580	GUIDE INLET VALVE	3				0.015	0.033
130	17321-13560	GUIDE EXHAUST VALVE	3				0.02	0.044
140	31351-32830	SENSOR THERMO	1				0.02	0.044
150	19013-03450	BOLT CYLINDER HEAD	14				0.077	0.1694
160	1G720-03310	GASKET CYL.HEAD	1				0.22	0.484
170	1G790-87210	LABEL PUMP	1				0.001	0.0022

GEAR CASE

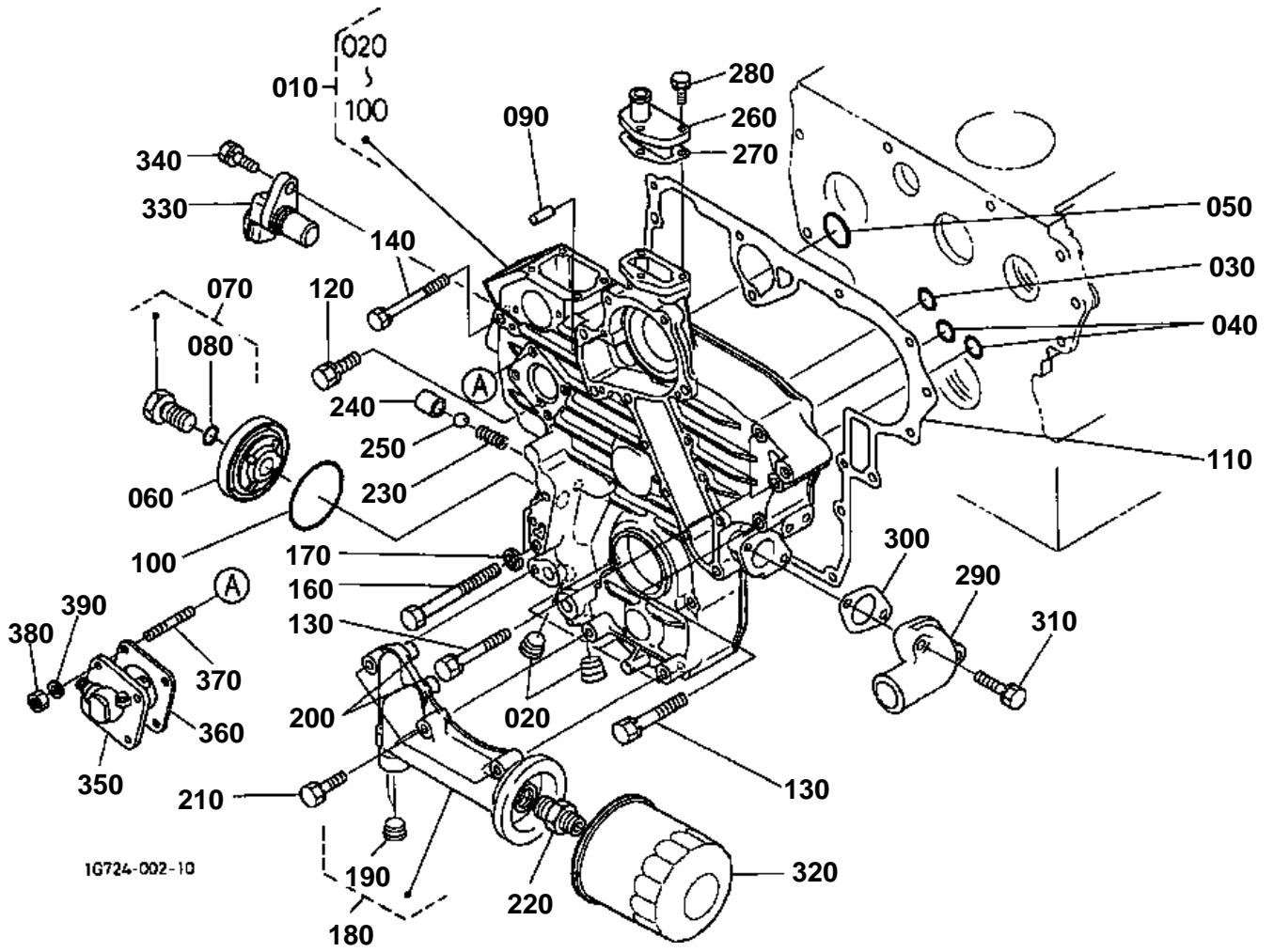



GEAR CASE

↔ Interchangeable; ≠ not interchangeable; ← new for old; → old for new

REF.No	Part No.	Description	Q'ty	S.No.	I/C	REMARKS	Weight (kgf)	Weight (lb)
010	1G723-04010	ASSY CASE GEAR	1				3.7	8.14
020	16241-96020	PLUG	2				0.015	0.033
030	04814-00150	O RING	1				0.001	0.0022
040	04814-00220	O RING	2				0.001	0.0022
050	04814-00360	O RING	1				0.001	0.0022
060	17331-32880	COVER	1				0.075	0.165
070	1A053-32910	COMP BOLT	1				0.066	0.1452
080	04814-00150	O RING	1				0.001	0.0022
090	05012-00612	PIN STRAIGHT	2				0.003	0.0066
100	19202-96830	O RING	1				0.01	0.022
110	1A021-04130	GASKET GEAR CASE	1				0.019	0.0418
120	01123-50835	BOLT	1				0.02	0.044
130	01123-50870	BOLT	7				0.029	0.0638
140	17367-91010	BOLT	1				0.005	0.011
150	99999-99999	BLANK	0				0	0
160	01153-50802	BOLT	2				0.04	0.088
170	04512-60080	WASHER SPRING	2				0.002	0.0044
180	1A053-32600	COMP.BASE OIL FILTER	1				0.505	1.111
190	16241-96020	PLUG	2				0.015	0.033
200	04814-00150	O RING	2				0.001	0.0022
210	01123-50840	BOLT	3				0.018	0.0396
220	15521-32293	JOINT PIPE	1				0.05	0.11
230	15241-36950	SPRING	1				0.004	0.0088
240	15521-36930	SEAT VALVE	1				0.015	0.033
250	07715-03213	BALL	1				0.004	0.0088
260	15521-73320	FLANGE WATER RETURN	1				0.04	0.088
270	1A021-73330	GASKET RETURN FLANGE	1				0.001	0.0022
280	01023-50620	BOLT	3				0.006	0.0132
290	1A053-72830	FLANGE WATER	1	<=2Q9999			0.135	0.297
290	1A053-72832	FLANGE WATER	1	>=2S0001	≠		0.135	0.297
300	1A053-72840	GASKET WATER FLANGE	1				0.001	0.0022
310	01123-50840	BOLT	2	<=2Q9999			0.018	0.0396
310	01123-50850	BOLT	2	>=2S0001	≠		0.02	0.044
320	1C020-32430	CARTRIDGE OIL FILTER	1				0.55	1.21
330	T1060-32270	SENSOR REVOLUTION	1				0.022	0.0484
340	01023-50616	BOLT	1				0.005	0.011
350	38240-34660	ASSY GEAR CASE H/M	1				0.335	0.737
360	15296-88130	GASKET H/METER UNIT	1				0.002	0.0044
370	15221-88210	STUD	4				0.005	0.011
380	02056-50060	NUT	4				0.002	0.0044
390	04512-60060	WASHER SPRING	4				0.001	0.0022

HEAD COVER

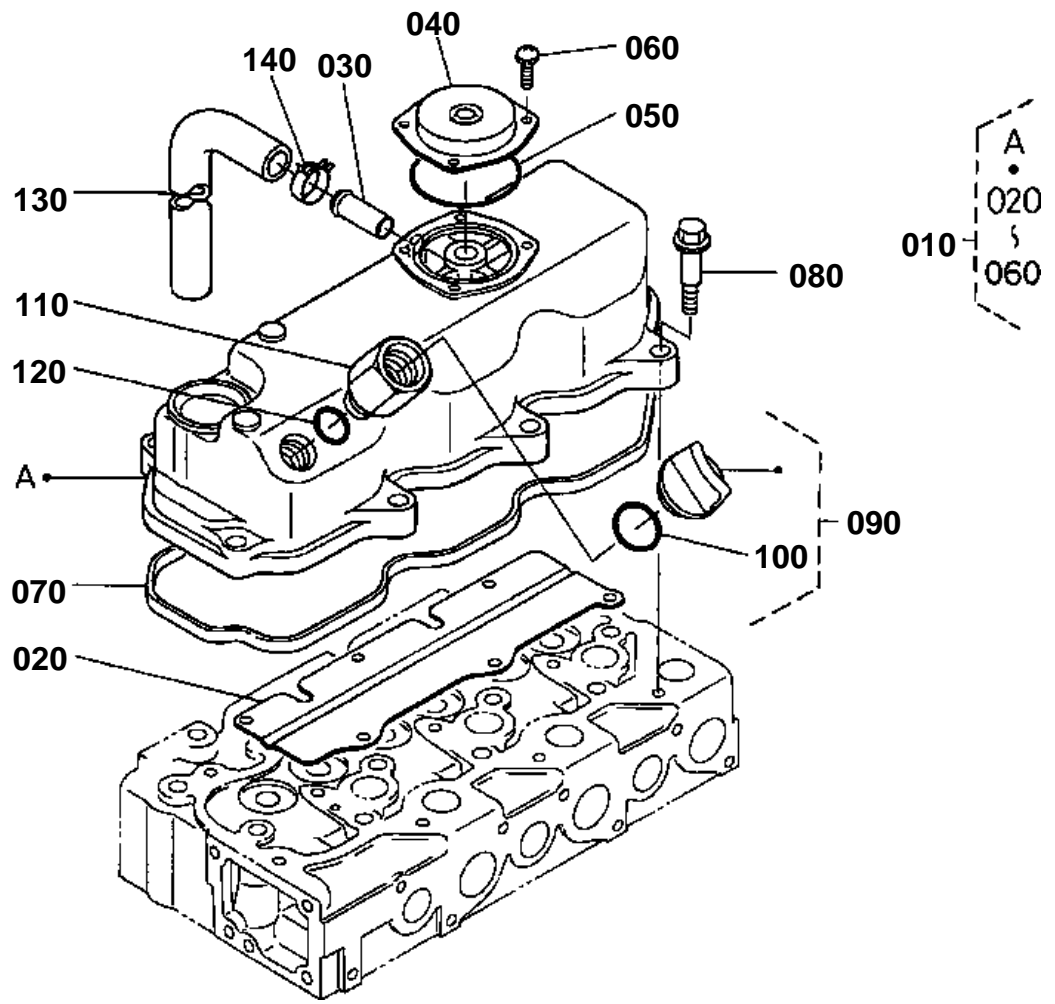

1G724-003-10



HEAD COVER

↔ Interchangeable; ≠ not interchangeable; ← new for old; → old for new

REF.No	Part No.	Description	Q'ty	S.No.	I/C	REMARKS	Weight (kgf)	Weight (lb)
010	1A053-14503	ASSY COVER CYL.HEAD	1				1.23	2.706
020	1A021-05370	SHIELD BREATHER	1				0.1	0.22
030	17331-73342	PIPE WATER RETURN	1				0.01	0.022
040	1A021-05120	COVER BREATHER	1				0.039	0.0858
050	1A021-05430	O RING BREATHER	1				0.001	0.0022
060	03024-50510	SCREW WITH WASHER	4				0.002	0.0044
070	1A021-14520	GASKET HEAD COVER	1				0.02	0.044
080	1G911-91020	BOLT	8	<=2B9999			0.015	0.033
080	1G911-91022	BOLT	8	>=2C0001	≠		0.015	0.033
090	1A053-33080	ASSY PLUG O/FILLER	1				0.013	0.0286
100	04814-06230	O RING	1				0.001	0.0022
110	RC411-42812	JOINT PIPE	1				0.24	0.528
120	04814-06230	O RING	1				0.001	0.0022
130	1A053-05510	TUBE BREATHER	1				0.005	0.011
140	09318-88150	CLAMP HOSE	1				0.004	0.0088

MAIN BEARING CASE

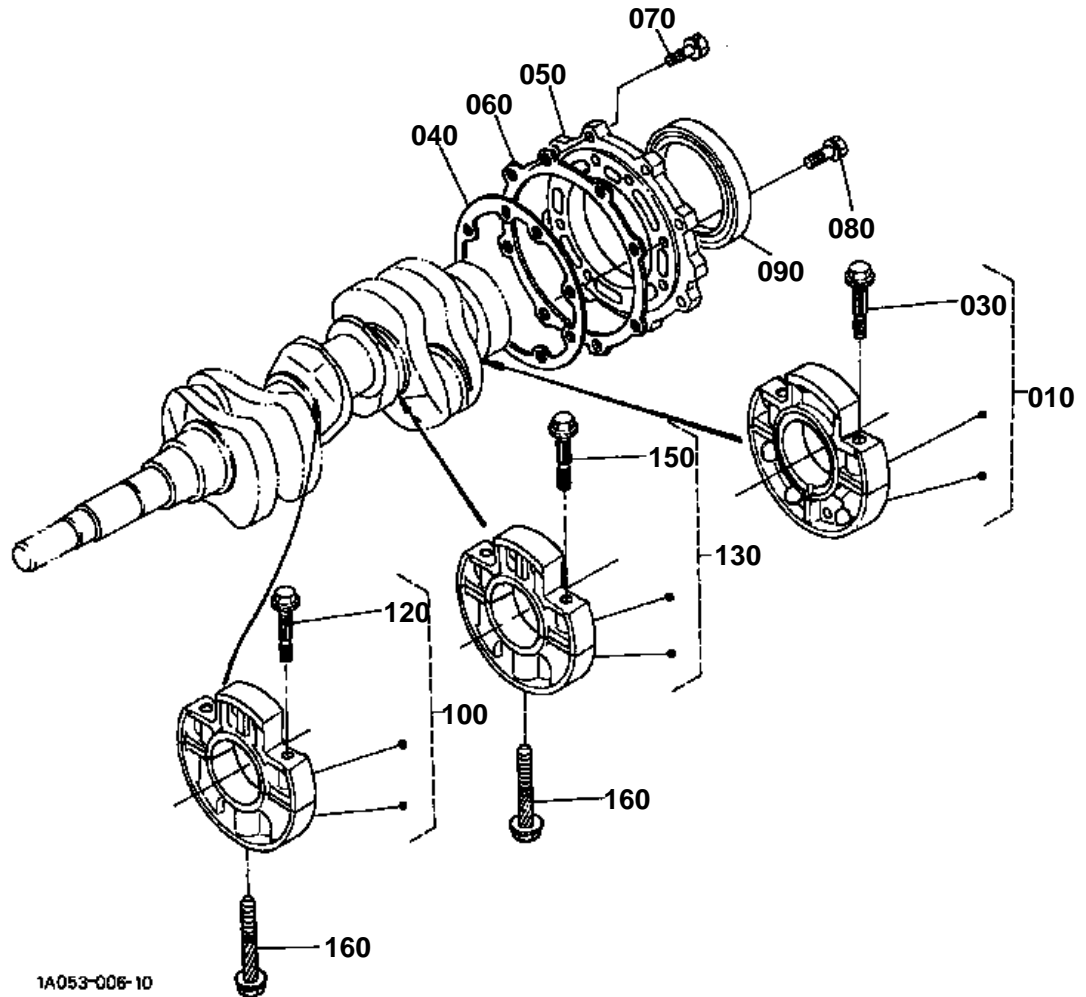



MAIN BEARING CASE

↔ Interchangeable; ≠ not interchangeable; ← new for old; → old for new

REF.No	Part No.	Description	Q'ty	S.No.	I/C	REMARKS	Weight (kgf)	Weight (lb)
010	19013-07090	ASSY BRG.CASE WHEEL	1				1.55	3.41
020	99999-99999	BLANK	0				0	0
030	19013-04540	BOLT BEARING CASE	2				0.038	0.0836
040	19077-04360	GASKET BEARING CASE	1				0.004	0.0088
050	19013-04813	COVER BEARING CASE	1				0.41	0.902
060	1A091-04820	GASKET CASE COVER	1				0.006	0.0132
070	01123-50825	BOLT	8				0.013	0.0286
080	01123-50828	BOLT	8				0.014	0.0308
090	19202-04460	SEAL OIL	1				0.055	0.121
100	19013-07040	ASSY BRG.CASE MAIN	1				1.5	3.3
110	99999-99999	BLANK	0				0	0
120	19013-04540	BOLT BEARING CASE	2				0.038	0.0836
130	19013-07050	ASSY BRG.CASE MAIN	1				1.495	3.289
140	99999-99999	BLANK	0				0	0
150	19013-04540	BOLT BEARING CASE	2				0.038	0.0836
160	15601-04560	BOLT BEARING CASE	2				0.06	0.132

CAMSHAFT AND IDLE GEAR SHAFT

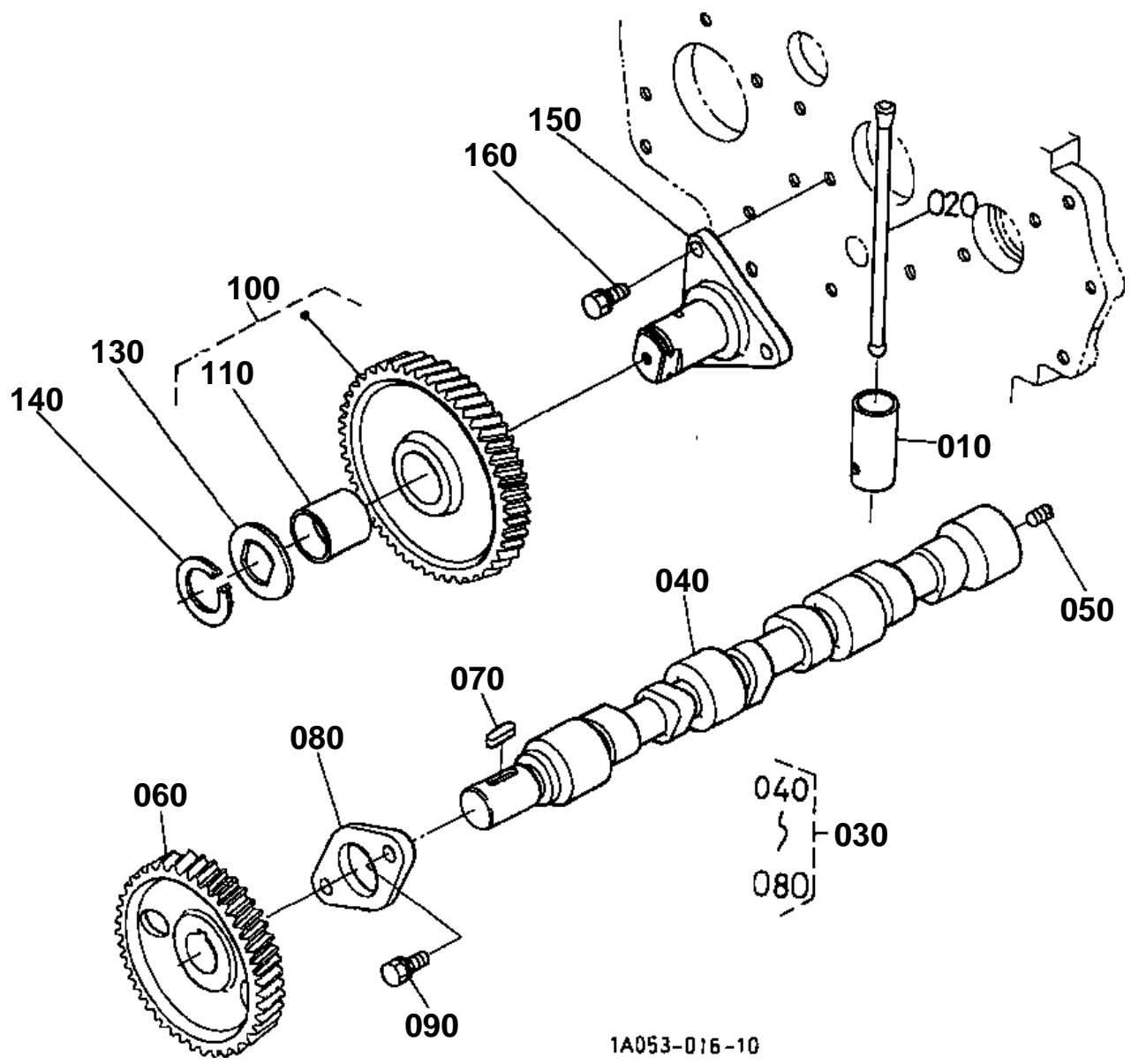



CAMSHAFT AND IDLE GEAR SHAFT

↔ Interchangeable; ≠ not interchangeable; ← new for old; → old for new

REF.No	Part No.	Description	Q'ty	S.No.	I/C	REMARKS	Weight (kgf)	Weight (lb)
010	15601-15550	TAPPET	6				0.08	0.176
020	19013-15110	PUSH ROD	6				0.05	0.11
030	17331-16010	ASSY CAMSHAFT	1				2.75	6.05
040	17331-16150	CAMSHAFT	1				1.795	3.949
050	15521-93610	SCREW SET	1				0.002	0.0044
060	15521-16510	GEAR CAM	1	<=1W1403			0.85	1.87
060	15521-16514	GEAR CAM	1	>=1Y0001	←		0	0
060	15521-16515	GEAR CAM	1	>=3G0001	←		0.85	1.87
070	05712-00720	KEY FEATHER	1				0.008	0.0176
080	15221-16270	STOPPER CAMSHAFT	1				0.073	0.1606
090	01123-50818	BOLT	2				0.012	0.0264
100	1A053-24010	COMP.GEAR IDLE	1	<=1Z9999			0	0
100	1G791-24010	COMP.GEAR IDLE	1	>=2A0001	←		1.195	2.629
110	1A021-24980	BUSH IDLE GEAR	1				0.072	0.1584
120	99999-99999	BLANK	0				0	0
130	1A021-24370	COLLAR	1				0.022	0.0484
140	15451-95400	CIR CLIP EXTERNAL	1				0.01	0.022
150	1A021-24250	SHAFT IDLE GEAR	1				0.685	1.507
160	01123-50818	BOLT	3				0.012	0.0264

PISTON AND CRANKSHAFT

