

Instructions for Parts Books

The heading at the top of the page will be the same for the picture of the parts at it is for the page with the part numbers.

Definition of column headings on part number pages:

REF.No → The number referring to the part on the picture page of the parts book.

Part No. → The number assigned to this part at the time of printing the parts book.

Description → Discription of part.

Q'ty → Quantity of part used on that page.

S.No. → Serial number range of the equipment that this part will fit.

>= Your serial number should be greater than or equal to the number shown.

<= Your serial number should be lesser than or equal to the serial number shown.

I/C → Interchangeability of part shown.

↔ The part shown will work for the older and later serial number.

The part shown is not interchangeable with the other serial number.

← new for old

→ old for new

Remarks → Notes about this particulart part. Sometimes this may say except [FR] or [CA]

Note about Country Codes:

The parts books we use in the United States of America may also contain information about a part that would be different in another country. It is important that you are aware of the country codes in some instances.

Symbol	Country
A	United States of America
CA	Canada
FR	France
GR	Greece
PO	Portugal
AU	Australia

If the remarks column says for example EXCEPT [FR] this part works in all countries except France. That means it will work here in the USA.

ALL PRODUCT INDEX
KX91-2

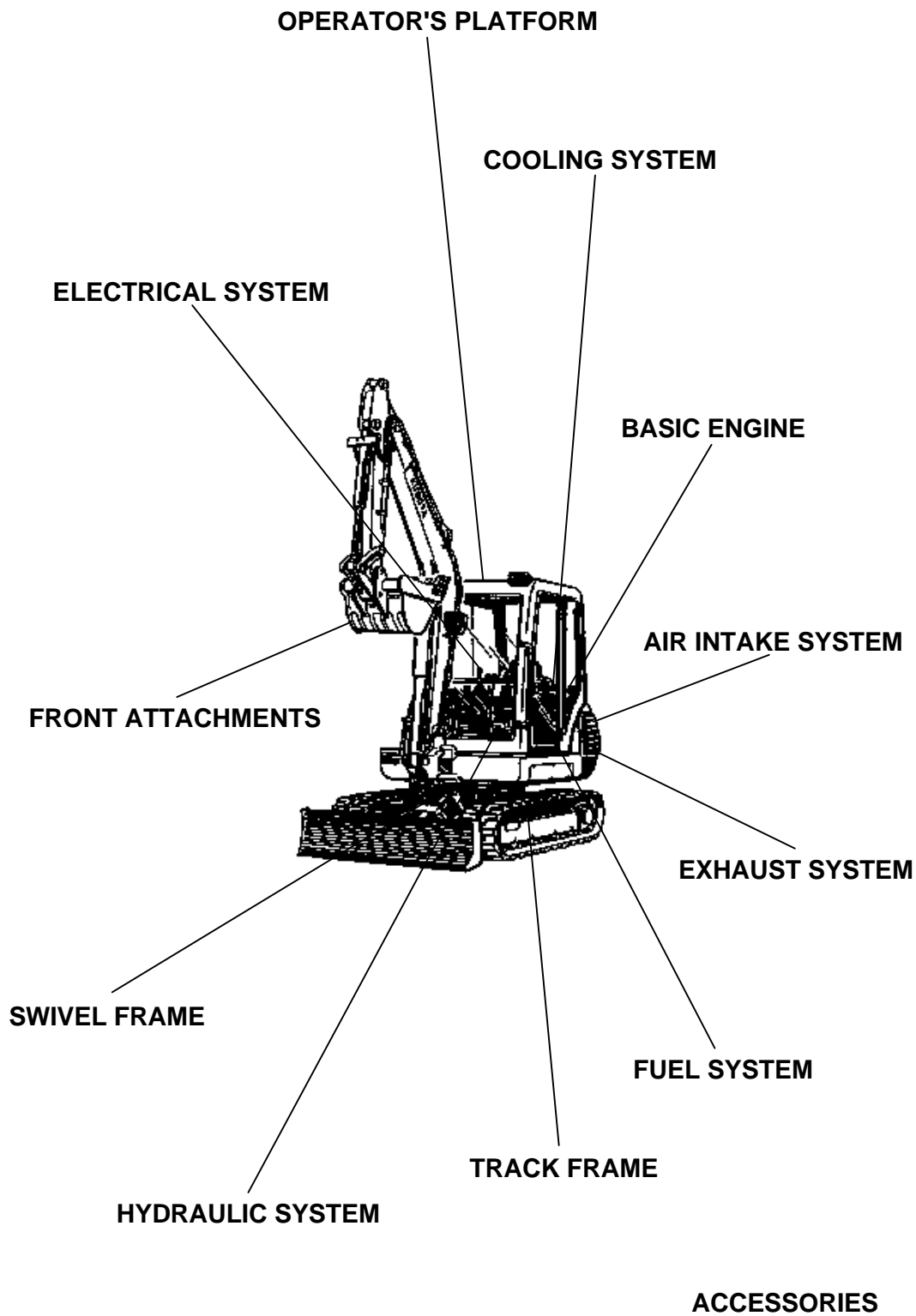

Item	Part No.	Description	Book
BASIC ENGINE	01S001	CRANKCASE	100A0035
	01S002	OIL PAN	100A0035
	01S003	PISTON AND CRANKSHAFT	100A0035
	01S004	MAIN BEARING CASE	100A0035
	01S005	CAMSHAFT	100A0035
	01S006	CYLINDER HEAD	100A0035
	01S007	VALVE AND ROCKER ARM	100A0035
	01S008	CYLINDER HEAD COVER	100A0035
	01S009	GEAR CASE	100A0035
	FUEL SYSTEM	01S013	NOZZLE HOLDER,GLOW PLUG
01S014		NOZZLE HOLDER [COMPONENT PARTS]	100A0035
01S015		SPEED CONTROL PLATE	100A0035
01S016		STOP SOLENOID	100A0035
01S017		GOVERNOR	100A0035
01S018		INJECTION PUMP	100A0035
01S020		FUEL CAMSHAFT	100A0035
COOLING SYSTEM		01S025	WATER FLANGE
	01S026	WATER PUMP	100A0035
	ELECTRICAL SYSTEM	01S029	FLYWHEEL,STARTER
01S030		STARTER [COMPONENT PARTS]	100A0035
01S031		ALTERNATOR	100A0035
01S032		ALTERNATOR [COMPONENT PARTS]	100A0035
BASIC ENGINE	02S010	ENGINE BRACKET	100A0035
AIR INTAKE SYSTEM	02S011	AIR CLEANER,INLET MANIFOLD	100A0035
EXHAUST SYSTEM	02S012	MUFFLER,EXHAUST MANIFOLD	100A0035
FUEL SYSTEM	02S021	ACCEL LEVER	100A0035
	02S022	FUEL PIPING	100A0035
	02S023	FUEL FILTER [COMPONENT PARTS]	100A0035
	02S024	FUEL TANK	100A0035
COOLING SYSTEM	02S027	RADIATOR	100A0035
	02S028	WATER PIPE	100A0035
ELECTRICAL SYSTEM	02S033	BATTERY	100A0035
	02S034	TIMER,HORN	100A0035
	02S035	SWITCH,METER	100A0035
	02S036	LIGHT	100A0035
HYDRAULIC SYSTEM	02S037	ELECTRICAL WIRING	100A0035
	02S038	PUMP HOUSING	100A0035
	02S039-1	PISTON PUMP AND COMPONENT PARTS	100A0035
	02S039-2	PISTON PUMP AND COMPONENT PARTS	100A0035
	02S040	HYDRAURIC PUMP AND COMPONENT PARTS	100A0035
	02S041-1	DRIVE MOTOR AND COMPONENT PARTS	100A0035
	02S041-2	DRIVE MOTOR AND COMPONENT PARTS	100A0035
	02S042	SWIVEL MOTOR AND COMPONENT PARTS	100A0035
	02S043	ROTARY JOINT	100A0035
	02S044	OIL TANK	100A0035
	02S045	CONTROL VALVE	100A0035
	02S046	CONTROL VALVE [COMPONENT PARTS]	100A0035
02S047-1	SPOOL SECTION (BUCKET)	100A0035	
02S047-2	SPOOL SECTION (BOOM)	100A0035	
02S047-3	SPOOL SECTION (TRAVEL RH)	100A0035	
02S047-4	SPOOL SECTION (TRAVEL LH)	100A0035	
02S047-5	SPOOL SECTION (ARM)	100A0035	
02S047-6	SPOOL SECTION (S/P)	100A0035	
02S047-7	SPOOL SECTION (TRAVEL STRAIGHT)	100A0035	
02S047-8	SPOOL SECTION (SWING/BLADE)	100A0035	
02S047-9	SPOOL SECTION (SWIVEL)	100A0035	
02S048	CHANGE VALVE	100A0035	

Item	Part No.	Description	Book
HYDRAULIC SYSTEM	02S049-1	CHANGE VALVE [COMPONENT PARTS]	100A0035
	02S049-2	CHANGE VALVE [COMPONENT PARTS]	100A0035
	02S050-1	MULTI VALVE	100A0035
	02S050-2	TPSS VALVE	100A0035
	02S051-1	MULTI VALVE [COMPONENT PARTS]	100A0035
	02S051-2	TPSS VALVE [COMPONENT PARTS]	100A0035
	02S052	CONTROL LEVER (FRAME)	100A0035
	02S053	CONTROL LEVER (LEVER LH)	100A0035
	02S054	CONTROL LEVER (LEVER RH)	100A0035
	02S055	PILOT VALVE [COMPONENT PARTS]	100A0035
	02S056	CONTROL LEVER (TRAVEL LH)	100A0035
	02S057	CONTROL LEVER (TRAVEL RH)	100A0035
	02S058	CONTROL TRAVEL PEDAL	100A0035
	02S059	CONTROL LEVER (SAFETY LOCK LEVER)	100A0035
	02S060	CONTROL PEDAL (SWIVEL/SWING CHANGE)	100A0035
	02S061-1	CONTROL LEVER (TPSS)	100A0035
	02S061-2	CONTROL LEVER (TPSS)	100A0035
	02S062	CONTROL LEVER (BLADE)	100A0035
	02S063	CONTROL LEVER (S/P 1)	100A0035
	02S064	CONTROL LEVER (S/P 2)	100A0035
	02S065	OIL PIPING (SUCTION)	100A0035
	02S066	OIL PIPING (DELIVERY)	100A0035
	02S067	OIL PIPING (RETURN)	100A0035
	02S068	OIL PIPING (OIL COOLER)	100A0035
	02S069	OIL PIPING (TRAVEL LH)	100A0035
	02S070	OIL PIPING (TRAVEL RH)	100A0035
	02S071-1	OIL PIPING (SWIVEL 1)	100A0035
	02S071-2	OIL PIPING (SWIVEL 1)	100A0035
	02S071-3	OIL PIPING (SWIVEL 1)	100A0035
	02S072	OIL PIPING (SWIVEL 2)	100A0035
	02S073	OIL PIPING (SWING)	100A0035
	02S074	OIL PIPING (LOCK)	100A0035
	02S075-1	OIL PIPING (BOOM 1)	100A0035
	02S075-2	OIL PIPING (BOOM 1)	100A0035
	02S075-3	OIL PIPING (BOOM 1)	100A0035
	02S076	OIL PIPING (BOOM 2)	100A0035
	02S077-1	OIL PIPING (ARM 1)	100A0035
	02S077-2	OIL PIPING (ARM 1)	100A0035
	02S077-3	OIL PIPING (ARM 1)	100A0035
	02S078	OIL PIPING (ARM 2)	100A0035
	02S079-1	OIL PIPING (BUCKET 1)	100A0035
	02S079-2	OIL PIPING (BUCKET 1)	100A0035
	02S080	OIL PIPING (BUCKET 2)	100A0035
	02S081	OIL PIPING (BLADE)	100A0035
	02S082	OIL PIPING (CLAMP)	100A0035
	02S083	OIL PIPING (S/P)	100A0035
	02S084	BOOM CYLINDER AND COMPONENT PARTS	100A0035
02S085	ARM CYLINDER AND COMPONENT PARTS	100A0035	
02S086	BUCKET CYLINDER AND COMPONENT PARTS	100A0035	
02S087	BLADE CYLINDER AND COMPONENT PARTS	100A0035	
02S088	SWING CYLINDER AND COMPONENT PARTS	100A0035	
FRONT ATTACHMENTS	02S089	SWING BRACKET	100A0035
	02S090	BOOM	100A0035
	02S091	CYLINDER COVER (BOOM)	100A0035
	02S092-1	ARM	100A0035
	02S092-2	ARM (TELESCOPIC)	100A0035
	02S092-3	TELESCOPIC CYLINDER [COMPONENT PARTS]	100A0035

Item	Part No.	Description	Book	
FRONT ATTACHMENTS	02S093-1	BUCKET LINK	100A0035	
	02S093-2	BUCKET LINK (TELESCOPIC)	100A0035	
TRACK FRAME	02S094	BUCKET	100A0035	
	02S095	BLADE	100A0035	
	02S096	TRACK FRAME	100A0035	
	02S097	IDLER	100A0035	
	02S098	TRACK ROLLER	100A0035	
	02S099	CRAWLER	100A0035	
SWIVEL FRAME	02S100	SWIVEL FRAME	100A0035	
	02S101	SWIVEL GEAR CASE	100A0035	
	02S102	SWIVEL GEAR	100A0035	
	02S103	SWIVEL BEARING	100A0035	
	02S104	SEAT SUPPORT	100A0035	
	02S105-1	STEP	100A0035	
	02S105-2	STEP	100A0035	
	02S106	COVER (LEFT)	100A0035	
	02S107	COVER (TANK)	100A0035	
	02S108	INSTRUMENT PANEL	100A0035	
	02S109	BONNET	100A0035	
	02S110	SPONGE (1)	100A0035	
	02S111	SPONGE (2)	100A0035	
	OPERATOR'S PLATFORM	02S112-1	WEIGHT	100A0035
02S112-2		WEIGHT (TELESCOPIC)	100A0035	
02S113		SEAT	100A0035	
02S114		CANOPY	100A0035	
02S115		CABIN (BODY)	100A0035	
02S116		CABIN (DOOR)	100A0035	
02S117		CABIN (WINDOW 1)	100A0035	
02S118		CABIN (WINDOW 2)	100A0035	
02S119		CABIN (SPONGE)	100A0035	
02S120		CABIN (ELECTRICAL WIRING)	100A0035	
02S121		CABIN (WIPER MOTOR)	100A0035	
02S122		CABIN (HEATER)	100A0035	
02S123		CABIN (DEFROSTER)	100A0035	
ACCESSORIES		02S124	LABEL	100A0035
		02S125	ACCESSORIES	100A0035
		02S126	WEIGHT KIT [OPTION]	100A0035
	02S127	LABEL KIT [OPTION]	100A0035	

CRANKCASE

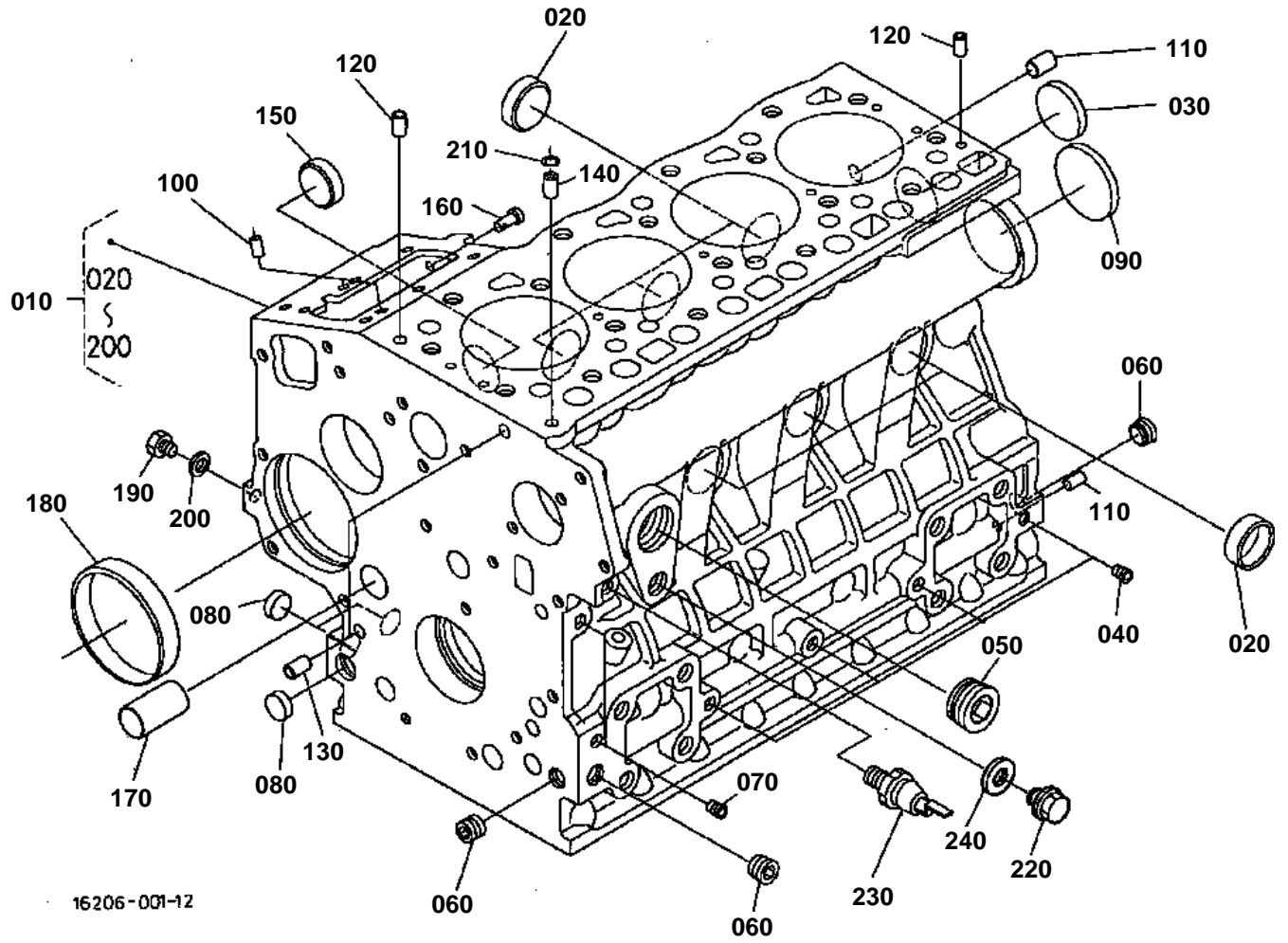

CRANKCASE

220 15841-7302-0



RG108-801-10



CRANKCASE

↔ Interchangeable; ≠ not interchangeable; ← new for old; → old for new

REF.No	Part No.	Description	Q'ty	S.No.	I/C	REMARKS	Weight (kgf)	Weight (lb)
010	16626-01010	COMP.CRANKCASE	1	<=116859			32.5	71.5
010	16626-01013	COMP.CRANKCASE	1	>=116860	≠		52	114.4
020	15451-96270	CAP SEALING	6				0.012	0.0264
030	15221-03490	CAP SEALING	1				0.02	0.044
040	15261-96010	PLUG	4				0.002	0.0044
050	16683-96020	PLUG	1				0.47	1.034
060	16241-96010	PLUG	3				0.007	0.0154
070	15521-96020	PLUG	2				0.003	0.0066
080	17391-96160	PLUG EXPANSION	3				0.003	0.0066
090	16271-96160	PLUG EXPANSION	1				0.025	0.055
100	05012-00508	PIN STRAIGHT	2	<=WT2678			0.001	0.0022
100	16225-94510	PIN STRAIGHT	2	>=WU0001	↔		0.001	0.0022
110	05012-00814	PIN STRAIGHT	2	<=WT2678			0.006	0.0132
110	16221-94530	PIN STRAIGHT	2	>=WU0001	↔		0.006	0.0132
120	05012-00610	PIN STRAIGHT	2	<=WT2678			0.003	0.0066
120	16221-94520	PIN STRAIGHT	2	>=WU0001	↔		0.005	0.011
130	15231-33960	PIN PIPE	2				0.001	0.0022
140	16241-33650	PIN PIPE	1				0.002	0.0044
150	16241-96262	PLUG	1	<=49889			0.007	0.0154
150	16241-96262	PLUG FUEL CAMSHAFT	1	>=49890	←		0.007	0.0154
160	15221-56280	PIN START SPRING	1				0.006	0.0132
170	16282-96010	PLUG	1				0.09	0.198
180	16271-55350	BUSH GOVERNOR GEAR	1				0.06	0.132
190	15221-33610	PLUG	1				0.009	0.0198
200	15021-33660	GASKET	1				0.001	0.0022
210	15221-33700	O RING	1				0.001	0.0022
220	15841-73020	ASSY COCK DRAIN	1	<=139735			0.03	0.066
220	06311-55020	PLUG	1	>=139736	←		0.031	0.0682
230	15531-39010	SWITCH OIL	1				0.032	0.0704
240	04714-00200	GASKET	1	>=139736			0.002	0.0044

OIL PAN

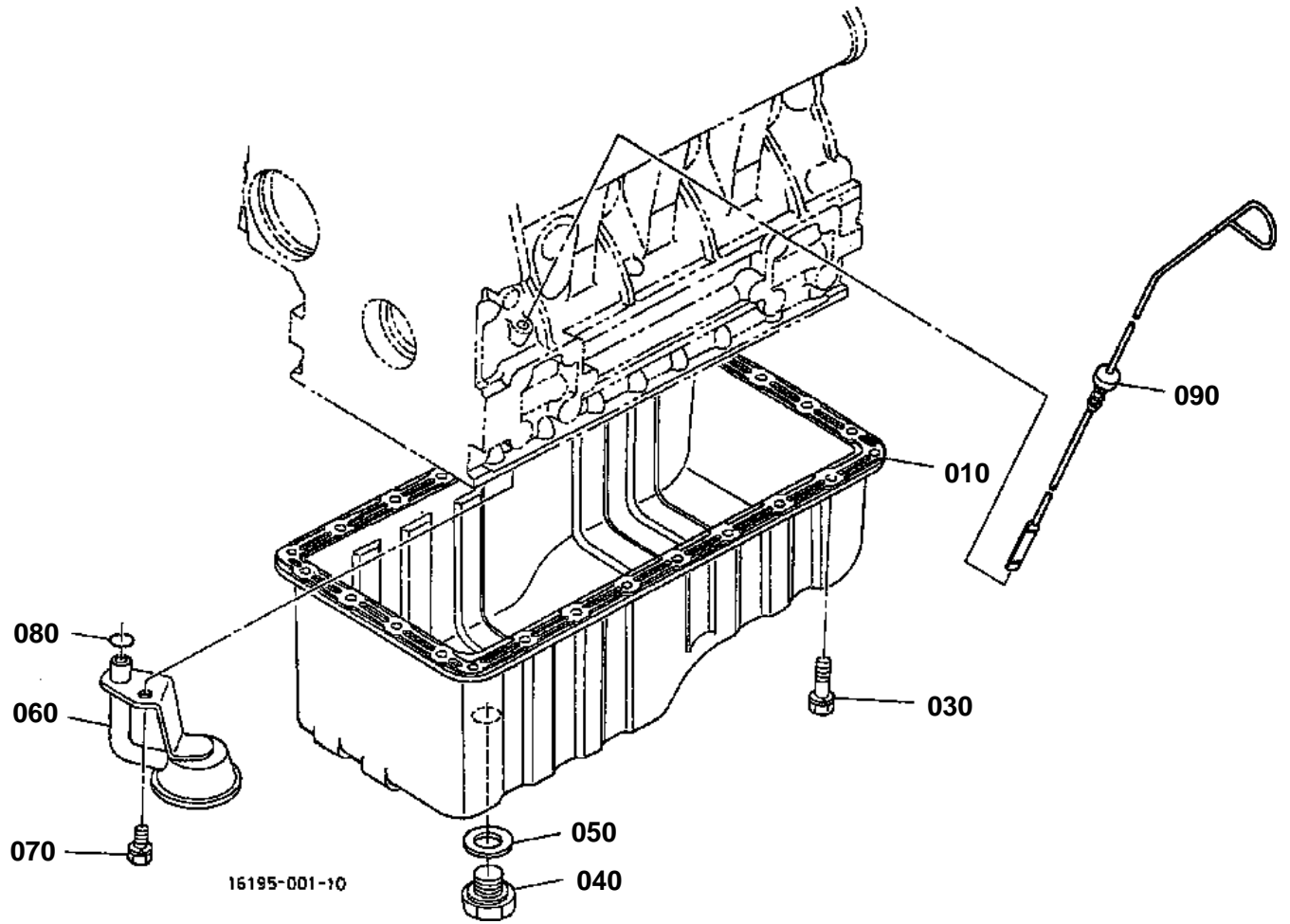

OIL PAN

020 16299-0162-0

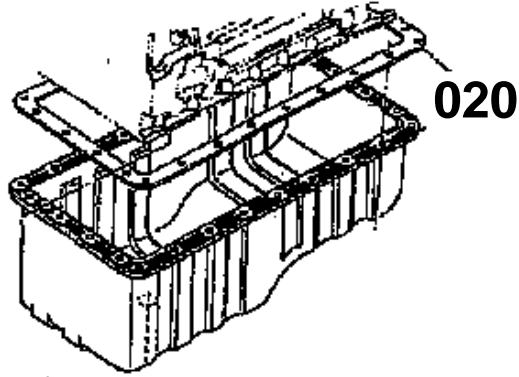

16195-800-10



OIL PAN

↔ Interchangeable; ≠ not interchangeable; ← new for old; → old for new

REF.No	Part No.	Description	Q'ty	S.No.	I/C	REMARKS	Weight (kgf)	Weight (lb)
010	16285-01500	COMP.OIL PAN	1				1.9	4.18
020	16299-01620	GASKET OIL PAN	1	≤=31856			0.003	0.0066
030	01023-50612	BOLT	26				0.005	0.011
040	16541-33750	PLUG DRAIN	1				0	0
050	15451-96670	GASKET	1				0.003	0.0066
060	16241-32114	FILTER OIL	1	≤=XB9999			0.25	0.55
060	16226-32110	FILTER OIL	1	≥=XC0001	←		0.28	0.616
070	01123-60816	BOLT	1				0.01	0.022
080	04814-00160	O RING	1				0.001	0.0022
090	16264-36413	GAUGE OIL	1				0.047	0.1034

PISTON AND CRANKSHAFT

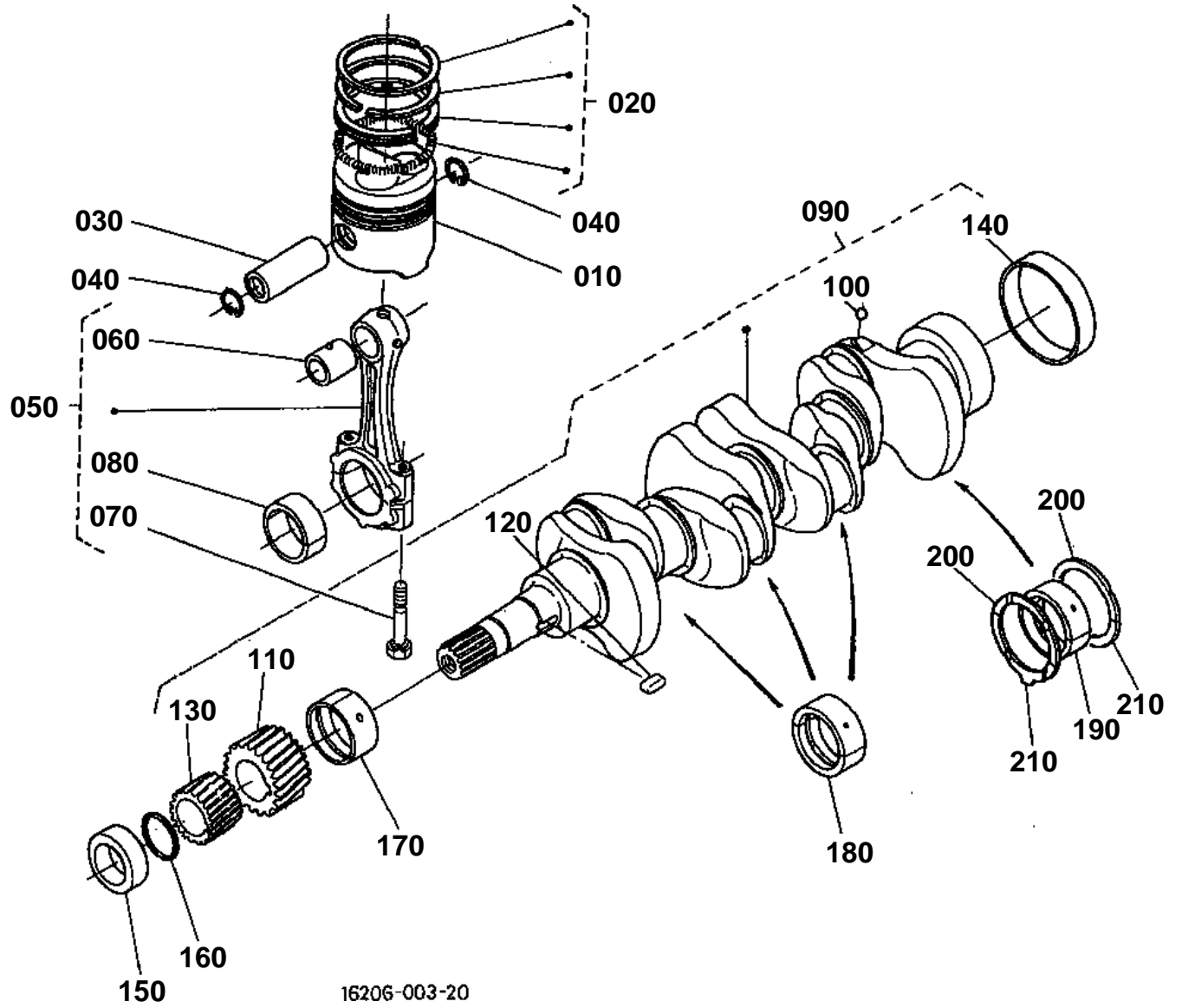



PISTON AND CRANKSHAFT

↔ Interchangeable; ≠ not interchangeable; ← new for old; → old for new

REF.No	Part No.	Description	Q'ty	S.No.	I/C	REMARKS	Weight (kgf)	Weight (lb)
010	16060-21110	PISTON	4			STD	0.4	0.88
010	16060-21910	PISTON	4			+0.5MM	0.415	0.913
010	16060-21910	PISTON	1		↔		0.415	0.913
020	16261-21050	ASSY PISTON RING	4			STD	0.042	0.0924
020	16261-21090	ASSY PISTON RING	4			+0.5MM	0.05	0.11
030	16241-21310	PIN PISTON	4				0.135	0.297
040	16241-21330	CIR CLIP PISTON PIN	8				0.002	0.0044
050	16241-22012	ASSY ROD CONNECTING	4				0.545	1.199
060	16241-21980	BUSH PISTON PIN	4				0.003	0.0066
070	16241-22140	BOLT CONNECTING ROD	8				0	0
080	16241-22310	METAL CRANKPIN	4			STD SET	0.038	0.0836
080	16241-22970	METAL CRANKPIN	4			-0.2MM SET	0.08	0.176
080	16241-22980	METAL CRANKPIN	4			-0.4MM SET	0.1	0.22
090	16282-23013	COMP.CRANKSHAFT	1				11	24.2
100	07715-00401	BALL	4				0.001	0.0022
110	16241-24110	GEAR CRANK	1				0.15	0.33
120	16271-95230	KEY	1				0.005	0.011
130	16241-35630	GEAR OIL PUMP DRIVE	1				0.102	0.2244
140	16241-23280	SLEEVE CRANKSHAFT	1				0.06	0.132
150	16241-23250	COLLAR CRANKSHAFT	1				0.05	0.11
160	15667-96750	O RING	1	≤=WH4447			0.02	0.044
160	04814-10280	O RING	1	≥=WJ0001	↔		0.001	0.0022
170	16241-23470	METAL CRANKSHAFT	1			STD	0.06	0.132
170	16241-23910	METAL CRANKSHAFT	1			-0.2MM	0.03	0.066
170	16241-23920	METAL CRANKSHAFT	1			-0.4MM	0.068	0.1496
180	16241-23480	METAL CRANKSHAFT	3			STD SET	0.05	0.11
180	16241-23930	METAL CRANKSHAFT	3			-0.2MM SET	0.1	0.22
180	16241-23940	METAL CRANKSHAFT	3			-0.4MM SET	0.05	0.11
190	16292-23490	METAL CRANKSHAFT	1			STD SET	0.07	0.154
190	16241-23860	METAL CRANKSHAFT	1			-0.2MM SET	0.1	0.22
190	16292-23860	METAL CRANKSHAFT	1		↔		0.05	0.11
190	16241-23870	METAL CRANKSHAFT	1			-0.4MM SET	0.068	0.1496
190	16292-23870	METAL CRANKSHAFT	1		↔		0.05	0.11
200	15521-23530	METAL SIDE	2			STD	0.01	0.022
200	15521-23950	METAL SIDE	2			+0.2MM	0.01	0.022
200	15521-23960	METAL SIDE	2			+0.4MM	0.01	0.022
210	19202-23540	METAL SIDE	2			STD	0.01	0.022
210	19202-23970	METAL SIDE	2			+0.2MM	0.01	0.022
210	19202-23980	METAL SIDE	2			+0.4MM	0.01	0.022



MAIN BEARING CASE

↔ Interchangeable; ≠ not interchangeable; ← new for old; → old for new

REF.No	Part No.	Description	Q'ty	S.No.	I/C	REMARKS	Weight (kgf)	Weight (lb)
010	16241-04092	ASSY CASE MAIN BRG.	1				1.13	2.486
020	16241-04540	BOLT BEARING CASE	2				0.02	0.044
030	16264-04360	GASKET BRG.CASE	1				0.002	0.0044
040	16241-04813	COVER BEARING CASE	1				0.22	0.484
050	16241-04460	SEAL OIL	1				0.02	0.044
060	16264-04820	GASKET	1				0.008	0.0176
070	01023-50625	BOLT	8				0.007	0.0154
080	01023-50620	BOLT	9				0.006	0.0132
090	16261-04040	ASSY CASE MAIN BRG.	1				0.9	1.98
100	16241-04540	BOLT BEARING CASE	2				0.02	0.044
110	16241-04560	BOLT BEARING CASE	3				0.03	0.066
120	16261-04050	ASSY CASE MAIN BRG.	1				1.11	2.442
130	16241-04540	BOLT BEARING CASE	2				0.02	0.044
140	16282-04060	ASSY CASE MAIN BRG.	1				1	2.2
150	16241-04540	BOLT BEARING CASE	2				0.02	0.044

CAMSHAFT

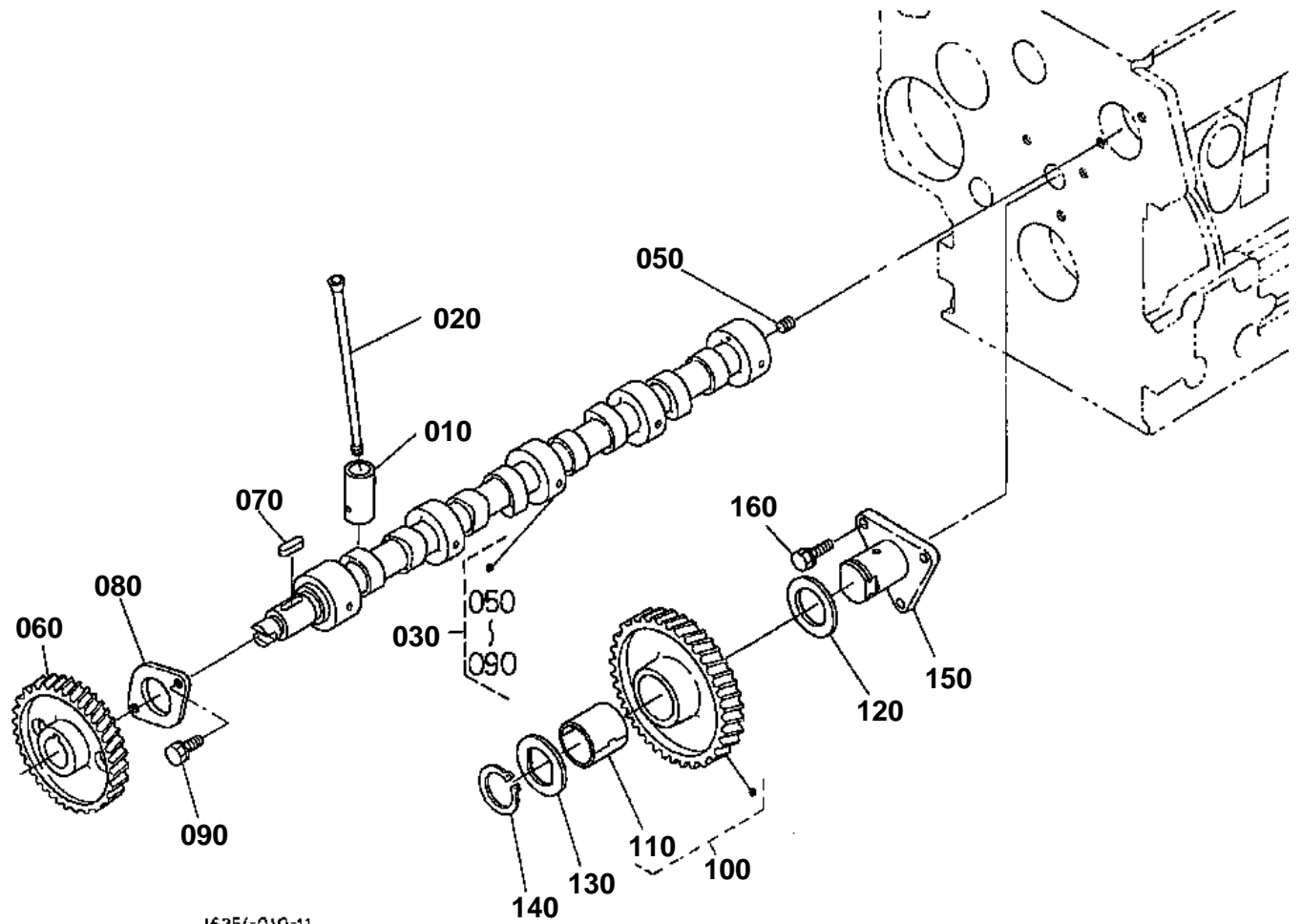

16254-010-11



CAMSHAFT

↔ Interchangeable; ≠ not interchangeable; ← new for old; → old for new

REF.No	Part No.	Description	Q'ty	S.No.	I/C	REMARKS	Weight (kgf)	Weight (lb)
010	16261-15550	TAPPET	8				0.035	0.077
020	16241-15110	PUSH ROD	8				0.03	0.066
030	16271-16010	ASSY CAMSHAFT	1				1.8	3.96
040	99999-99999	BLANK	0				0	0
050	15521-93610	SCREW SET	1				0.002	0.0044
060	16241-16510	GEAR CAM	1				0.45	0.99
070	05712-00518	KEY FEATHER	1				0.003	0.0066
080	16241-16270	STOPPER CAMSHAFT	1				0.04	0.088
090	01023-50614	BOLT	2				0.005	0.011
100	16271-24010	COMP GEAR IDLE	1				0.6	1.32
110	16271-24980	BUSH IDLE GEAR	1				0.02	0.044
120	16241-24360	COLLAR IDLE GEAR	1				0.01	0.022
130	16241-24370	COLLAR IDLE GEAR	1				0.012	0.0264
140	16241-24320	CIR CLIP IDLE GEAR	1				0.003	0.0066
150	16241-24250	SHAFT IDLE GEAR	1				0.255	0.561
160	01023-50616	BOLT	3				0.005	0.011

CYLINDER HEAD

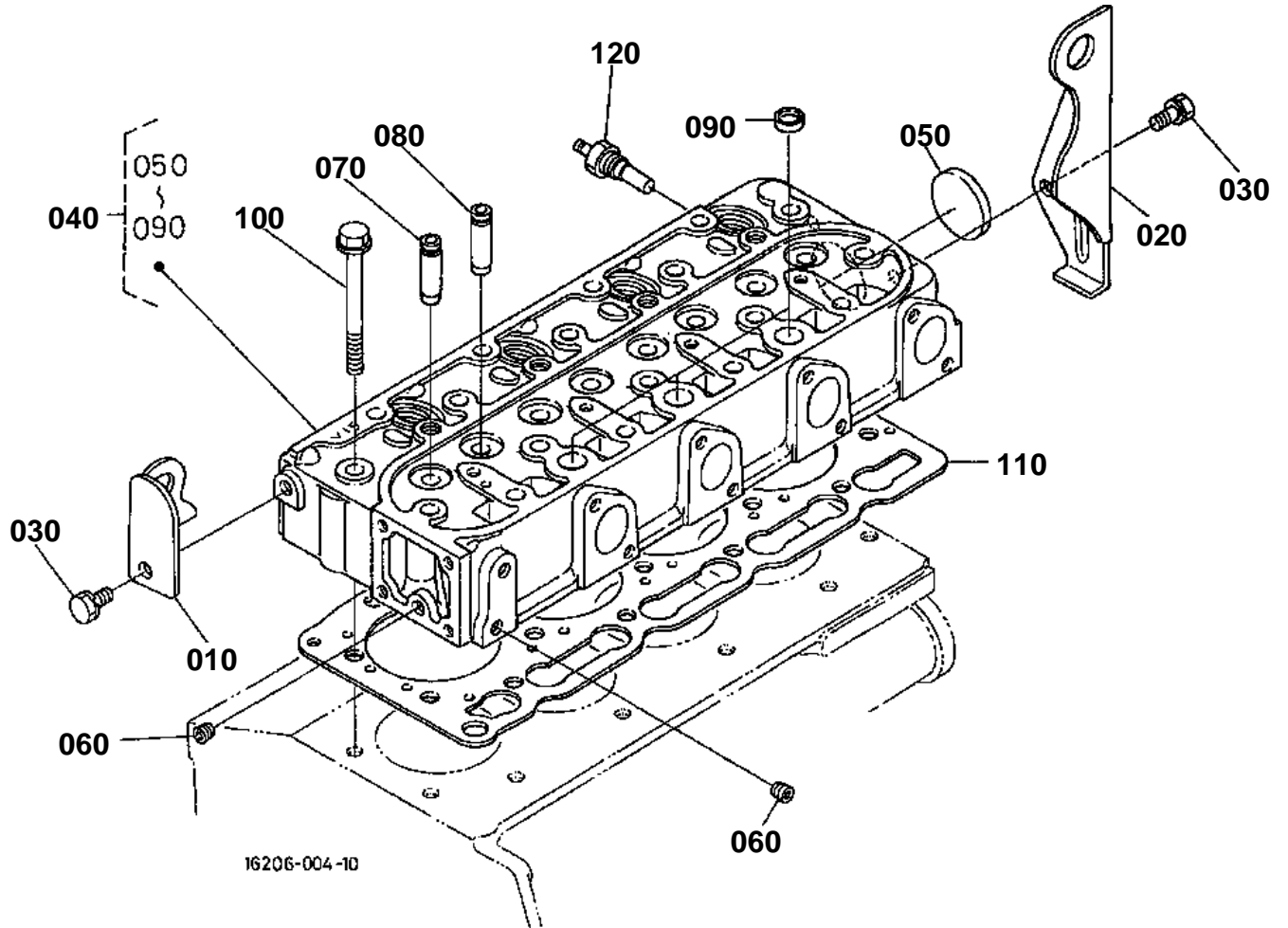



CYLINDER HEAD

↔ Interchangeable; ≠ not interchangeable; ← new for old; → old for new

REF.No	Part No.	Description	Q'ty	S.No.	I/C	REMARKS	Weight (kgf)	Weight (lb)
010	16241-01750	HOOK ENGINE	1				0.08	0.176
020	16241-01770	HOOK ENGINE	1				0.175	0.385
030	01123-60814	BOLT	2				0.01	0.022
040	16062-03040	COMP.CYLINDER HEAD	1	<=116859			12.5	27.5
040	16062-03042	COMP.CYLINDER HEAD	1	>=116860	≠		11.5	25.3
050	15321-96260	CAP SEALING	1				0.014	0.0308
060	15261-96010	PLUG	2				0.002	0.0044
070	16241-13540	GUIDE INLET VALVE	4				0.02	0.044
080	16241-13560	GUIDE EXHAUST VALVE	4				0.01	0.022
090	15261-03370	CAP SEALING	3				0.005	0.011
100	16241-03450	BOLT CYLINDER HEAD	18				0.07	0.154
110	16282-03310	GASKET CYLINDER HEAD	1	<=116859			0.085	0.187
110	16292-03310	GASKET CYLINDER HEAD	1	>=116860	≠		0.09	0.198
120	31351-32830	SENSOR THERMO	1				0.02	0.044

