

Instructions for Parts Books

The heading at the top of the page will be the same for the picture of the parts at it is for the page with the part numbers.

Definition of column headings on part number pages:

REF.No → The number referring to the part on the picture page of the parts book.

Part No. → The number assigned to this part at the time of printing the parts book.

Description → Discription of part.

Q'ty → Quantity of part used on that page.

S.No. → Serial number range of the equipment that this part will fit.

>= Your serial number should be greater than or equal to the number shown.

<= Your serial number should be lesser than or equal to the serial number shown.

I/C → Interchangeability of part shown.

↔ The part shown will work for the older and later serial number.

The part shown is not interchangeable with the other serial number.

← new for old

→ old for new

Remarks → Notes about this particulart part. Sometimes this may say except [FR] or [CA]

Note about Country Codes:

The parts books we use in the United States of America may also contain information about a part that would be different in another country. It is important that you are aware of the country codes in some instances.

Symbol	Country
A	United States of America
CA	Canada
FR	France
GR	Greece
PO	Portugal
AU	Australia

If the remarks column says for example EXCEPT [FR] this part works in all countries except France. That means it will work here in the USA.

ALL PRODUCT INDEX
KX41H

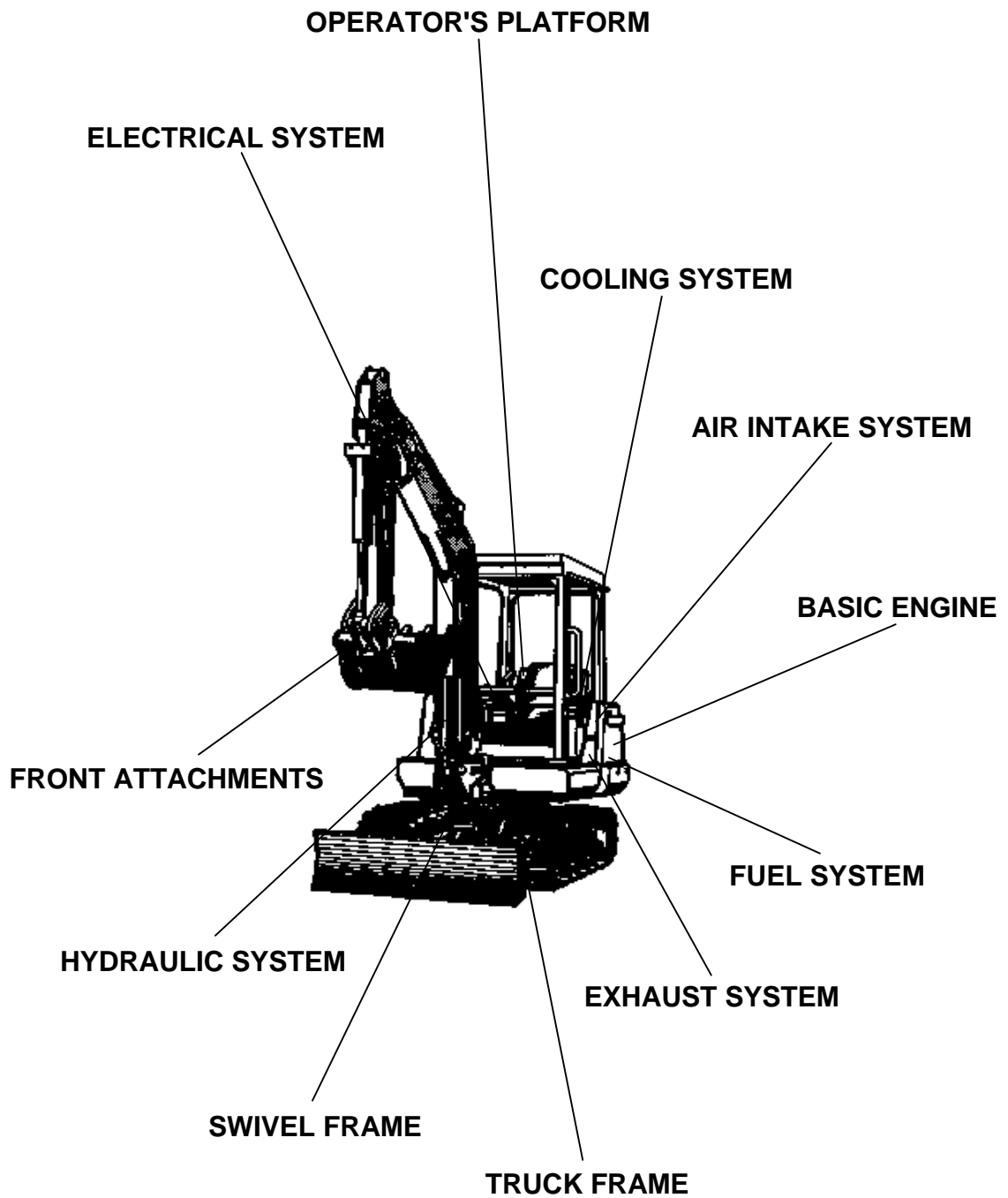

ACCESSORIES

Item	Part No.	Description	Book
BASIC ENGINE	01S001	CRANKCASE	100K0290
	01S002	OIL PAN	100K0290
	01S003	PISTON CRANKSHAFT	100K0290
	01S004	MAIN BEARING CASE	100K0290
	01S005	CAMSHAFT	100K0290
	01S006	CYLINDER HEAD	100K0290
	01S007	VALVE ROCKER ARM	100K0290
	01S008	CYLINDER HEAD COVER	100K0290
	01S009	GEAR CASE	100K0290
FUEL SYSTEM	01S013	NOZZLE HOLDER GLOW PLUG	100K0290
	01S01401	NOZZLE HOLDER (COMPONENT PARTS)	100K0290
	01S01402	NOZZLE HOLDER (COMPONENT PARTS)	100K0290
	01S01501	SPEED CONTROL PLATE	100K0290
	01S01502	SPEED CONTROL PLATE	100K0290
	01S016	STOP SOLENOID	100K0290
	01S017	GOVERNOR	100K0290
	01S018	INJECTION PUMP CAMSHAFT (1)	100K0290
	01S01901	INJECTION PUMP (COMPONENT PARTS)	100K0290
01S020	INJECTION PUMP CAMSHAFT (2)	100K0290	
ELECTRICAL SYSTEM	01S028	FLYWHEEL STARTER	100K0290
	01S02901	STARTER (COMPONENT PARTS)	100K0290
	01S02902	STARTER (COMPONENT PARTS)	100K0290
	01S03001	DYNAMO EXCEPT [KTA]	100K0290
	01S031	DYNAMO (COMPONENT PARTS)	100K0290
BASIC ENGINE	01S010	ENGINE BRACKET	100K0290
AIR INTAKE SYSTEM	01S01101	AIR CLEANER INLET MANIFOLD EXCEPT [KTA]	100K0290
EXHAUST SYSTEM	01S012	MUFFLER EXHAUST MANIFOLD	100K0290
FUEL SYSTEM	01S021	ACCEL LEVER	100K0290
	01S022	FUEL PIPING	100K0290
	01S023	FUEL TANK	100K0290
COOLING SYSTEM	01S024	WATER FLANGE	100K0290
	01S025	WATER PUMP	100K0290
	01S026	RADIATOR	100K0290
	01S027	WATER PIPE	100K0290
ELECTRICAL SYSTEM	01S032	BATTERY	100K0290
	01S033	REGULATOR HORN	100K0290
	01S034	SWITCH METER	100K0290
HYDRAULIC SYSTEM	01S035	ELECTRICAL WIRING	100K0290
	01S036	PUMP HOUSING	100K0290
	01S037	GEAR PUMP & COMPONENT PARTS	100K0290
	01S038	DRIVE MOTOR & COMPONENT PARTS	100K0290
	01S039	SWIVEL MOTOR & COMPONENT PARTS	100K0290
	01S040	ROTARY JOINT	100K0290
	01S041	OIL TANK	100K0290
	01S04201	CONTROL VALVE (1) EXCEPT [KTA]	100K0290
	01S043	CONTROL VALVE (1) (COMPONENT PARTS)	100K0290
	01S04401	SPOOL SECTION (BUCKET)	100K0290
	01S04402	SPOOL SECTION (BOOM)	100K0290
	01S04403	SPOOL SECTION (TRAVEL RH)	100K0290
	01S04404	SPOOL SECTION	100K0290
	01S04405	SPOOL SECTION (ARM)	100K0290
	01S04406	SPOOL SECTION (TRAVEL LH)	100K0290
01S04407	SPOOL SECTION (S/P)	100K0290	
01S045	CONTROL VALVE (3)	100K0290	
01S046	CONTROL VALVE (3) (COMPONENT PARTS)	100K0290	
01S04701	SPOOL SECTION (SWIVEL)	100K0290	
01S04702	SPOOL SECTION (SWING)	100K0290	
01S04703	SPOOL SECTION (BLADE)	100K0290	
01S048	CONTROL LEVER (FRAME)	100K0290	

Item	Part No.	Description	Book	
HYDRAULIC SYSTEM	01S049	CONTROL LEVER (BOX LH)	100K0290	
	01S050	CONTROL LEVER (LEVER LH-1)	100K0290	
	01S051	CONTROL LEVER (LEVER LH-2)	100K0290	
	01S052	CONTROL LEVER (BOX RH)	100K0290	
	01S053	CONTROL LEVER (LEVER RH-1)	100K0290	
	01S054	CONTROL LEVER (LEVER RH-2)	100K0290	
	01S055	CONTROL LEVER (TRAVEL LH)	100K0290	
	01S056	CONTROL LEVER (TRAVEL RH)	100K0290	
	01S057	CONTROL LEVER (SAFETY LOCK LEVER)	100K0290	
	01S058	CONTROL PEDAL (SWIVEL/SWING CHANGE)	100K0290	
	01S059	CONTROL LEVER (BLADE)	100K0290	
	01S060	CONTROL LEVER (S/P)	100K0290	
	01S061	OIL PIPING (THIRD LINE)	100K0290	
	01S062	OIL PIPING (SUCTION DELIVERY)	100K0290	
	01S06301	OIL PIPING (HYDRAULIC PORT)	100K0290	
	01S06302	OIL PIPING (HYDRAULIC PORT)	100K0290	
	01S06401	OIL PIPING (RETURN C/V TANK) EXCEPT [KTA]	100K0290	
	01S06501	OIL PIPING (OIL COOLER) EXCEPT [KTA]	100K0290	
	01S066	OIL PIPING (TRAVEL LH)	100K0290	
	01S067	OIL PIPING (TRAVEL RH)	100K0290	
	01S06801	OIL PIPING (SWIVEL) EXCEPT [KTA]	100K0290	
	01S069	OIL PIPING (SWING)	100K0290	
	01S070	OIL PIPING (BOOM)	100K0290	
	01S071	OIL PIPING (ARM)	100K0290	
	01S072	OIL PIPING (BUCKET)	100K0290	
	01S073	OIL PIPING (BLADE)	100K0290	
	01S074	OIL PIPING (CUSHION)	100K0290	
	01S075	OIL PIPING (S/P)	100K0290	
	01S076	BOOM CYLINDER & COMPONENT PARTS	100K0290	
	01S077	ARM CYLINDER & COMPONENT PARTS	100K0290	
	01S078	BUCKET CYLINDER & COMPONENT PARTS	100K0290	
	01S079	BLADE CYLINDER & COMPONENT PARTS	100K0290	
	01S080	SWING CYLINDER & COMPONENT PARTS	100K0290	
	FRONT ATTACHMENTS	01S081	SWING BRACKET	100K0290
		01S082	BOOM	100K0290
		01S083	CYLINDER COVER (BOOM)	100K0290
		01S084	ARM	100K0290
		01S085	BUCKET LINK	100K0290
		01S086	BUCKET	100K0290
		01S087	BLADE	100K0290
	TRUCK FRAME	01S088	TRUCK FRAME	100K0290
		01S089	IDLER	100K0290
		01S090	TRUCK ROLLER	100K0290
SWIVEL FRAME	01S091	CRAWLER	100K0290	
	01S092	SWIVEL FRAME	100K0290	
	01S093	SWIVEL BEARING	100K0290	
	01S094	FLOOR PLATE	100K0290	
	01S095	BONNET	100K0290	
	01S09602	SPONGE (1) [KTC KCL KTA]	100K0290	
	01S097	SPONGE (2)	100K0290	
OPERATOR'S PLATFORM	01S098	WEIGHT	100K0290	
	01S09902	CANOPY (ROPS) [KTC KCL KTA]	100K0290	
	01S100	INSTRUMENT PANEL	100K0290	
	01S10103	SEAT [KTC KCL KTA] [COSTA-RICA ECUADOR TURKISHREF]	100K0290	
ACCESSORIES	01S102	LIGHT	100K0290	
	01S10302	LABEL [KTC KCL KTA]	100K0290	
	01S104	ACCESSORIES	100K0290	

CRANKCASE

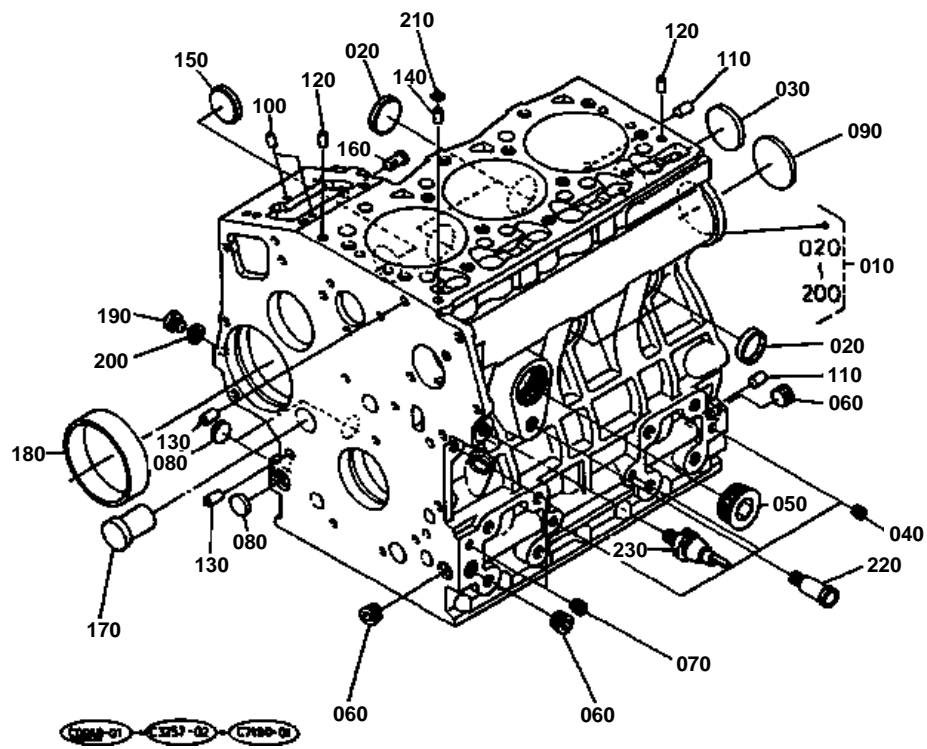



CRANKCASE

↔ Interchangeable; ≠ not interchangeable; ← new for old; → old for new

REF.No	Part No.	Description	Q'ty	S.No.	I/C	REMARKS	Weight (kgf)	Weight (lb)
010	16265-01012	COMP.CRANKCASE	1	<=425160			0	0
010	16265-01015	COMP.CRANKCASE	1	>=425161	←		31.5	69.3
010	16613-01010	COMP.CRANKCASE	1	>=559356	←		31.47	69.234
020	15451-96270	CAP SEALING	4				0.012	0.0264
030	15221-03490	CAP SEALING	1				0.02	0.044
040	15261-96010	PLUG	3				0.002	0.0044
050	16683-96020	PLUG	1				0.47	1.034
060	16241-96010	PLUG	3				0.007	0.0154
070	15521-96020	PLUG	2				0.003	0.0066
080	06311-75018	PLUG	3	<=308554			0.004	0.0088
080	17391-96160	PLUG	3	>=308555	←		0.003	0.0066
090	16271-96160	PLUG	1				0.025	0.055
100	05012-00508	PIN STRAIGHT	2				0.001	0.0022
110	05012-00814	PIN STRAIGHT	2				0.006	0.0132
120	05012-00610	PIN STRAIGHT	2				0.003	0.0066
130	15231-33960	PIN PIPE	2				0.001	0.0022
140	16241-33650	PIN PIPE	1				0.002	0.0044
150	16241-96260	PLUG	1				0	0
160	16261-56280	PIN START SPRING	1				0.004	0.0088
170	16282-96010	PLUG	1				0.09	0.198
180	16271-55350	BUSH GOVERNOR GEAR	1				0.06	0.132
190	15221-33610	PLUG	1				0.009	0.0198
200	15021-33660	GASKET	1				0.001	0.0022
210	15221-33700	O RING	1				0.001	0.0022
220	15321-73340	PIPE WATER RETURN	1				0.016	0.0352
230	15531-39010	SWITCH OIL	1				0.032	0.0704

OIL PAN

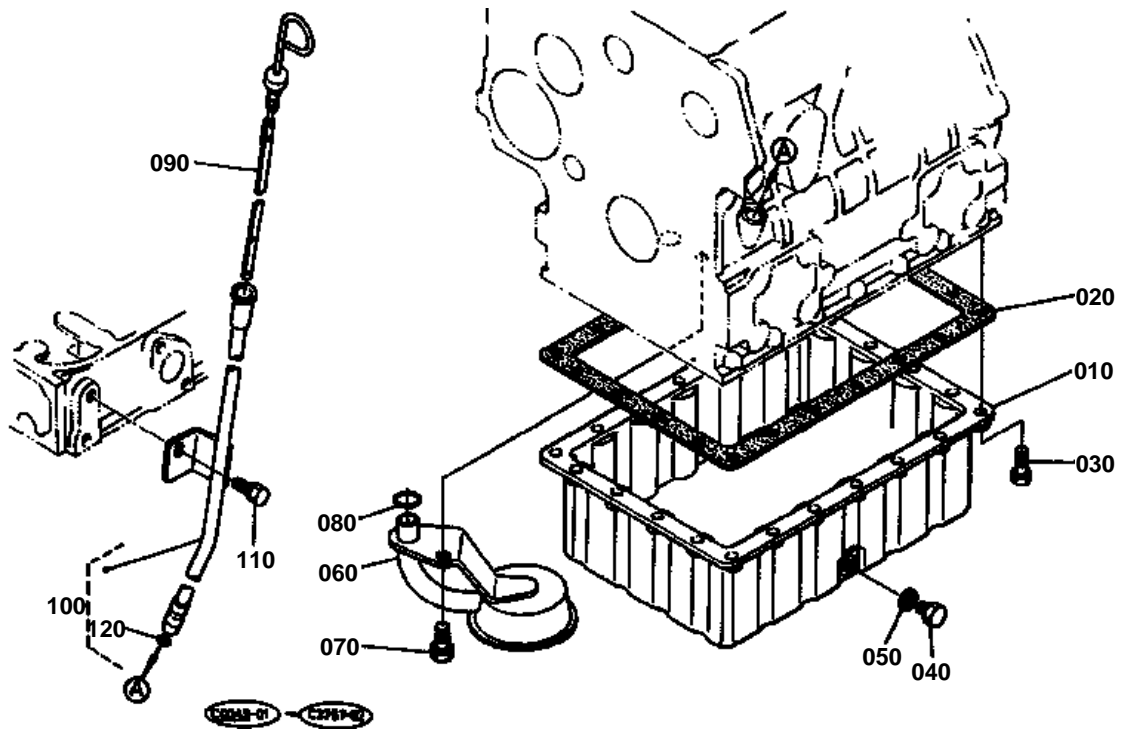



OIL PAN

↔ Interchangeable; ≠ not interchangeable; ← new for old; → old for new

REF.No	Part No.	Description	Q'ty	S.No.	I/C	REMARKS	Weight (kgf)	Weight (lb)
010	16204-01610	OIL PAN	1				3.6	7.92
020	16261-01620	GASKET OIL PAN	1	<=534271			0	0
020	16261-01630	GASKET OIL PAN NA	1	>=534272	←		0.001	0.0022
030	01023-50618	BOLT	22				0.006	0.0132
040	15221-33750	PLUG	1				0.032	0.0704
050	15109-33660	GASKET	1				0.001	0.0022
060	16261-32110	FILTER OIL	1	<=534271			0	0
060	16261-32113	FILTER OIL	1	>=534272	←		0	0
070	01123-50816	BOLT	1				0	0
080	04814-00160	O RING	1				0.001	0.0022
090	16204-36410	GAUGE OIL	1				0	0
100	16282-36420	GUIDE OIL GAUGE	1	<=425160			0.11	0.242
100	16282-36500	ASSY GUIDE OIL GAUGE	1	>=425161	≠		0.11	0.242
110	01123-50814	BOLT	1				0	0
120	04814-00090	O RING	1	>=425161			0.001	0.0022

PISTON CRANKSHAFT

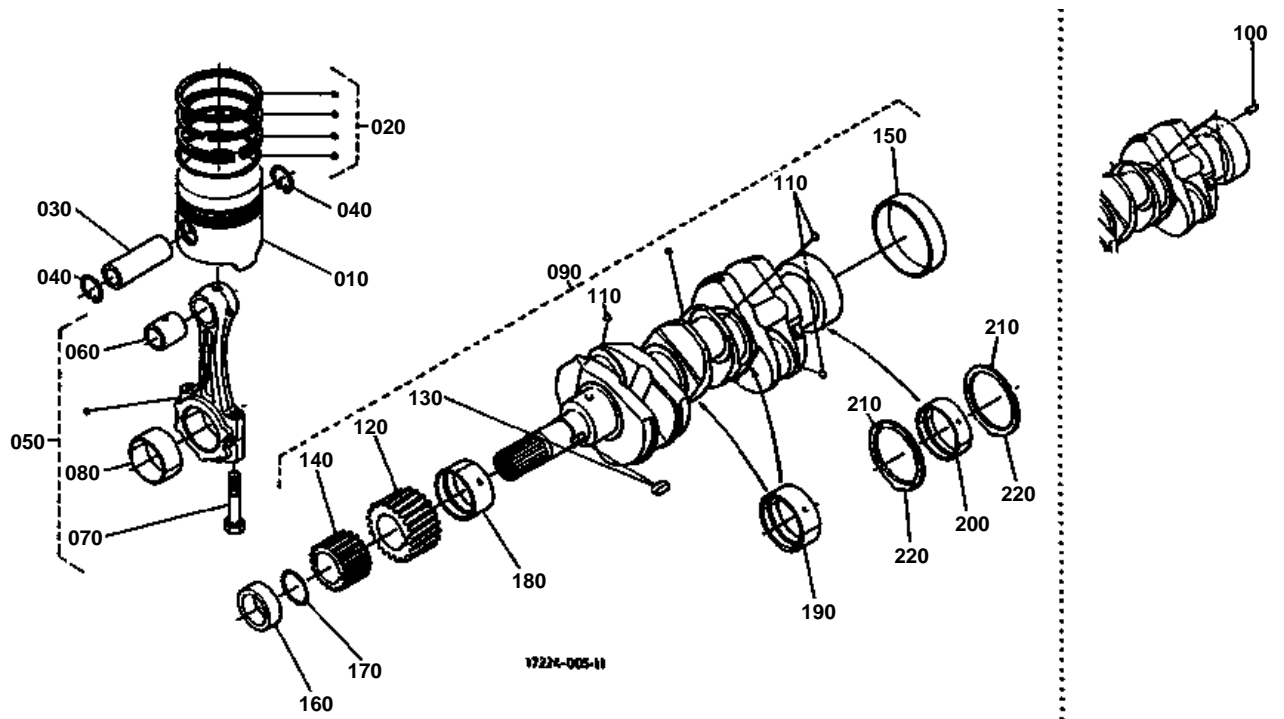



PISTON CRANKSHAFT

↔ Interchangeable; ≠ not interchangeable; ← new for old; → old for new

REF.No	Part No.	Description	Q'ty	S.No.	I/C	REMARKS	Weight (kgf)	Weight (lb)
010	16281-21110	PISTON	3	<=489915		STD	0	0
010	16060-21110	PISTON	3	>=489916	←	STD	0.4	0.88
010	16281-21910	PISTON	3	<=489915		+0.5MM	0	0
010	16060-21910	PISTON	3	>=489916	←	+0.5MM	0.415	0.913
020	16261-21050	ASSY PISTON RING	3			STD	0.042	0.0924
020	16261-21090	ASSY PISTON RING	3			+0.5MM	0.05	0.11
030	16241-21310	PIN PISTON	3				0.135	0.297
040	16241-21330	CIR CLIP PISTON PIN	6				0.002	0.0044
050	16241-22012	ASSY CONNECTING ROD	3				0.545	1.199
060	16241-21980	BUSH PISTON PIN	3				0.03	0.066
070	16241-22140	BOLT CONNECTING ROD	6				0.024	0.0528
080	16241-22310	METAL CRANKPIN	3			SET STD	0.038	0.0836
080	16241-22970	METAL CRANKPIN	1			SET -0.2MM	0.08	0.176
080	16241-22980	METAL CRANKPIN	1			SET -0.4MM	0.1	0.22
090	16265-23010	COMP.CRANKSHAFT	1	<=482630			0	0
090	16265-23013	COMP.CRANKSHAFT	1	>=482631	→		8.2	18.04
100	05012-00508	PIN STRAIGHT	1	<=482630			0.001	0.0022
110	07715-00401	BALL	3				0.001	0.0022
120	16241-24110	GEAR CRANKSHAFT	1				0.15	0.33
130	16271-95230	KEY	1				0.005	0.011
140	16241-35630	GEAR OIL PUMP DRIVE	1				0.102	0.2244
150	16241-23280	SLEEVE CRANKSHAFT	1				0.06	0.132
160	16241-23250	COLLAR CRANKSHAFT	1				0.05	0.11
170	15667-96750	O RING	1				0.02	0.044
180	16241-23470	METAL CRANKSHAFT	1			STD	0.06	0.132
180	16241-23910	METAL CRANKSHAFT	1			-0.2MM	0.03	0.066
180	16241-23920	METAL CRANKSHAFT	1			-0.4MM	0.068	0.1496
190	16241-23480	METAL CRANKSHAFT	2			SET STD	0.05	0.11
190	16241-23930	METAL CRANKSHAFT	2			SET -0.2MM	0.1	0.22
190	16241-23940	METAL CRANKSHAFT	2			SET -0.4MM	0.05	0.11
200	16241-23490	METAL CRANKSHAFT	1			SET STD	0	0
200	16241-23860	METAL CRANKSHAFT	1			SET -0.2MM	0.1	0.22
200	16241-23870	METAL CRANKSHAFT	1			SET -0.4MM	0.068	0.1496
210	15521-23530	METAL SIDE	2			STD	0.01	0.022
210	15521-23950	METAL SIDE	2			+0.2MM	0.01	0.022
210	15521-23960	METAL SIDE	2			+0.4MM	0.01	0.022
220	19202-23540	METAL SIDE	2			STD	0.01	0.022
220	19202-23970	METAL SIDE	2			+0.2MM	0.01	0.022
220	19202-23980	METAL SIDE	2			+0.4MM	0.01	0.022

MAIN BEARING CASE

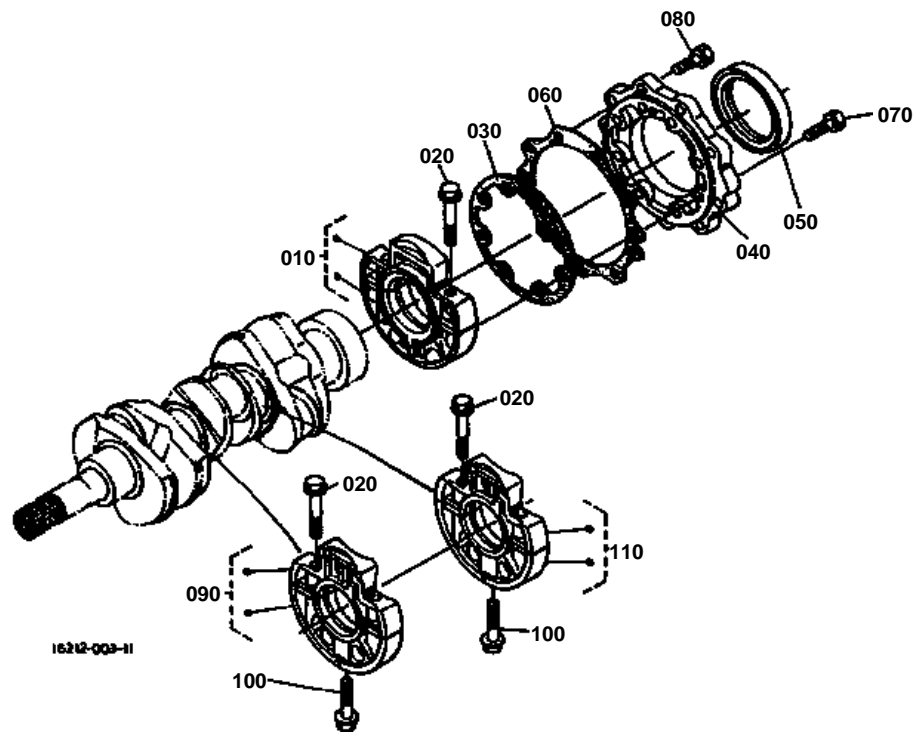



MAIN BEARING CASE

↔ Interchangeable; ≠ not interchangeable; ← new for old; → old for new

REF.No	Part No.	Description	Q'ty	S.No.	I/C	REMARKS	Weight (kgf)	Weight (lb)
010	16261-04090	ASSY CASE MAIN BRG.	1	≤568291			0	0
010	16241-04092	ASSY CASE MAIN BRG.	1	≥568292	↔		1.13	2.486
020	16241-04540	BOLT BEARING CASE	6				0.02	0.044
030	16299-04360	GASKET BRG.CASE NA	1	≤534271			0	0
030	16264-04360	GASKET BRG.CASE NA	1	≥534272	←		0.002	0.0044
040	16241-04810	COVER BEARING CASE	1	≤475253			0	0
040	16241-04813	COVER BEARING CASE	1	≥475254	←		0.22	0.484
050	16241-04460	SEAL OIL	1				0.02	0.044
060	16299-04820	GASKET BRG.CASE COV.	1	≤534271			0	0
060	16264-04820	GASKET BRG.CASE COV.	1	≥534272	←		0.008	0.0176
070	01023-50625	BOLT	8				0.007	0.0154
080	01023-50620	BOLT	9				0.006	0.0132
090	16261-04040	ASSY CASE MAIN BRG.	1				0.9	1.98
100	16241-04560	BOLT BEARING CASE	2				0.03	0.066
110	16261-04050	ASSY CASE MAIN BRG.	1				1.11	2.442

CAMSHAFT

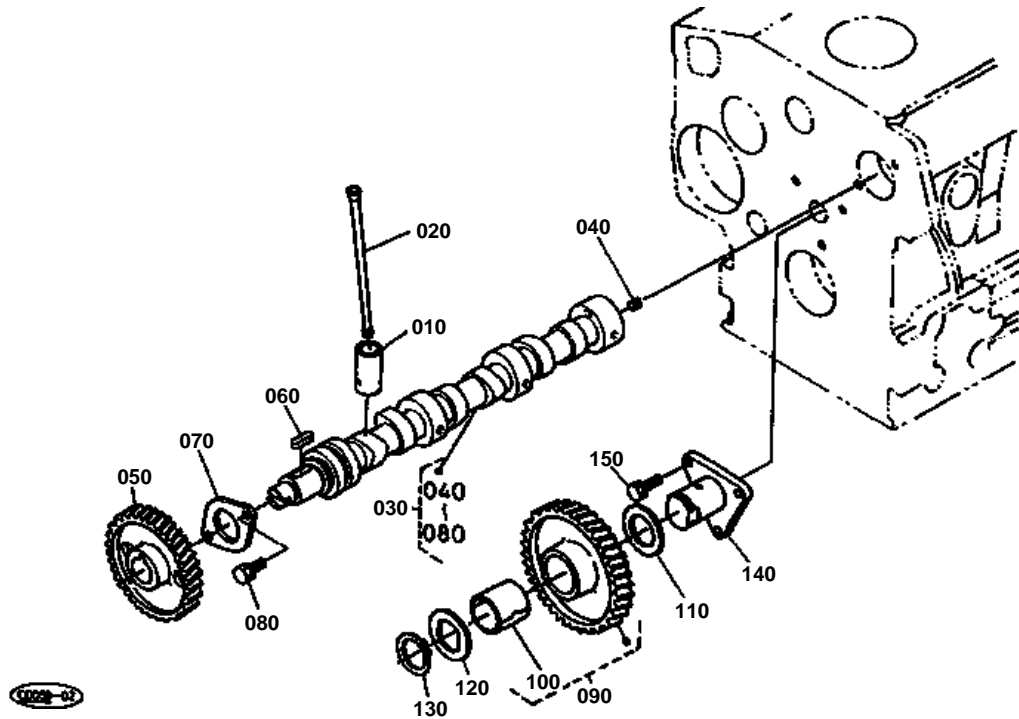



CAMSHAFT

↔ Interchangeable; ≠ not interchangeable; ← new for old; → old for new

REF.No	Part No.	Description	Q'ty	S.No.	I/C	REMARKS	Weight (kgf)	Weight (lb)
010	16261-15550	TAPPET	6				0.035	0.077
020	16241-15110	PUSH ROD	6				0.03	0.066
030	16261-16010	ASSY CAMSHAFT	1				1.7	3.74
040	15521-93610	SCREW SET	1				0.002	0.0044
050	16241-16510	GEAR CAMSHAFT	1				0.45	0.99
060	05712-00518	KEY FEATHER	1				0.003	0.0066
070	16241-16270	STOPPER CAMSHAFT	1				0.04	0.088
080	01023-50614	BOLT	2				0.005	0.011
090	16271-24010	COMP GEAR IDLE	1				0.6	1.32
100	16271-24980	BUSH IDLE GEAR	1				0.02	0.044
110	16241-24360	COLLAR IDLE GEAR	1				0.01	0.022
120	16241-24370	COLLAR IDLE GEAR	1				0.012	0.0264
130	16241-24320	CIR CLIP IDLE GEAR	1				0.003	0.0066
140	16241-24250	SHAFT IDLE GEAR	1				0.255	0.561
150	01023-50616	BOLT	3				0.005	0.011

CYLINDER HEAD

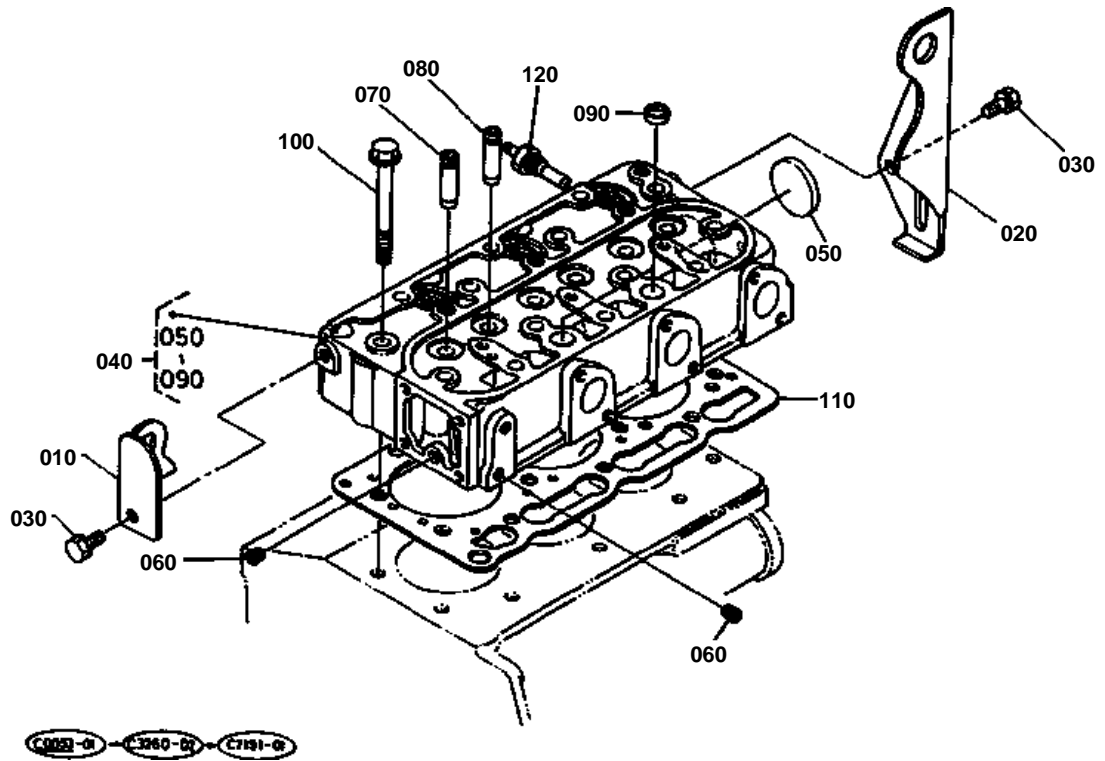



CYLINDER HEAD

↔ Interchangeable; ≠ not interchangeable; ← new for old; → old for new

REF.No	Part No.	Description	Q'ty	S.No.	I/C	REMARKS	Weight (kgf)	Weight (lb)
010	16241-01750	HOOK ENGINE	1				0.08	0.176
020	16241-01770	HOOK ENGINE	1				0.175	0.385
030	01123-50814	BOLT	2				0	0
040	16261-03040	COMP.CYLINDER HEAD	1	<=489915			10	22
040	16032-03040	COMP.CYLINDER HEAD	1	>=489916	≠		10	22
050	15321-96260	CAP SEALING	1				0.014	0.0308
060	15261-96010	PLUG	2				0.002	0.0044
070	16241-13540	GUIDE INLET VALVE	3				0.02	0.044
080	16241-13560	GUIDE EXHAUST VALVE	3				0.01	0.022
090	15261-03370	CAP SEALING	2				0.005	0.011
100	16241-03450	BOLT CYLINDER HEAD	14				0.07	0.154
110	16261-03310	GASKET CYLINDER HEAD	1				0.07	0.154
120	31351-32830	THERMOSTAT UNIT	1				0.02	0.044

VALVE ROCKER ARM

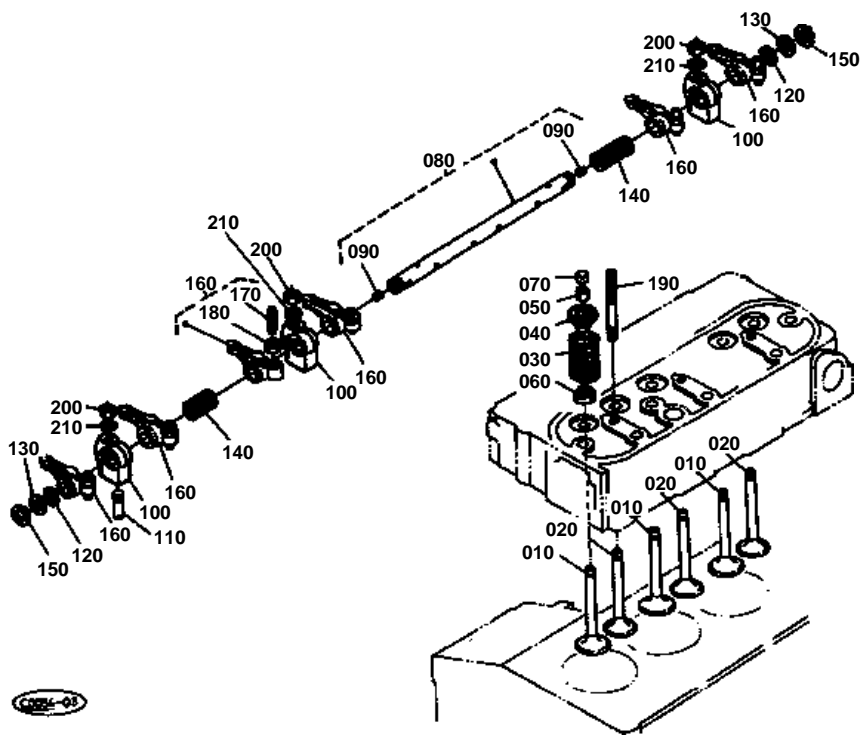



VALVE ROCKER ARM

↔ Interchangeable; ≠ not interchangeable; ← new for old; → old for new

REF.No	Part No.	Description	Q'ty	S.No.	I/C	REMARKS	Weight (kgf)	Weight (lb)
010	16241-13110	VALVE INLET	3				0.05	0.11
020	16241-13120	VALVE EXHAUST	3				0.045	0.099
030	16271-13240	SPRING VALVE	6				0.015	0.033
040	16241-13330	RETAINER VALVE SP.	6				0.015	0.033
050	15261-13360	COLLET VALVE SPRING	6			SET	0.001	0.0022
060	16241-13150	SEAL VALVE STEM	6				0.002	0.0044
070	15261-13280	CAP VALVE	6	≤338135			0	0
070	16241-13280	CAP VALVE	6	≥338136	↔		0.005	0.011
080	16261-14050	ASSY SHAFT R-ARM	1				0.17	0.374
090	03410-50606	SCREW SET	2				0.001	0.0022
100	16241-14350	BRACKET ROCKER ARM	3				0.04	0.088
110	15261-14420	SCREW SET.ROCKER ARM	1				0.002	0.0044
120	16241-14430	WASHER R-ARM.SHAFT	2				0.002	0.0044
130	16241-14440	WASHER R-ARM.SHAFT	2				0.002	0.0044
140	16241-14310	SPRING ROCKER ARM	2				0.004	0.0088
150	04612-00120	CIR CLIP EXTERNAL	2				0.001	0.0022
160	16241-14030	ASSY ROCKER ARM	6				0.06	0.132
170	16241-14230	SCREW ADJUSTING	6				0.008	0.0176
180	16241-14240	NUT	6				0.004	0.0088
190	16241-14410	STUD	3				0.022	0.0484
200	15261-92010	NUT	3				0.005	0.011
210	15261-94010	WASHER PLAIN	3				0.002	0.0044

CYLINDER HEAD COVER

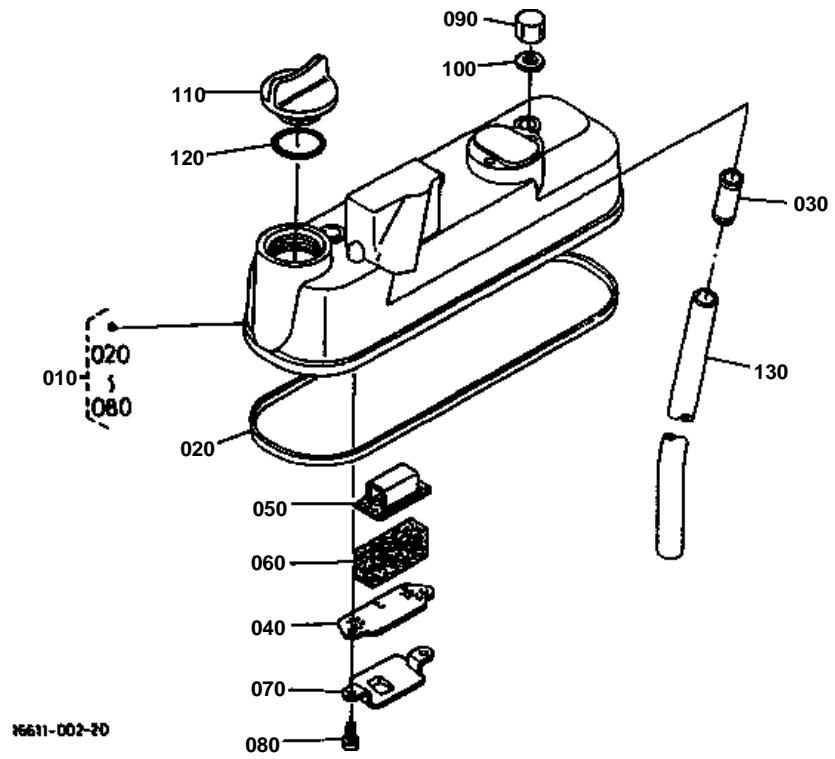

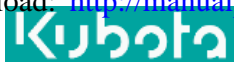

CYLINDER HEAD COVER

↔ Interchangeable; ≠ not interchangeable; ← new for old; → old for new

REF.No	Part No.	Description	Q'ty	S.No.	I/C	REMARKS	Weight (kgf)	Weight (lb)
010	16261-14510	COVER CYL.HEAD	1	≤534271			0	0
010	16261-14503	ASSY COVER CYL. HEA	1	≥534272	←		0.78	1.716
020	16261-14520	GASKET HEAD COVER	1				0.01	0.022
030	16241-05550	JOINT BREATHER PIPE	1				0.02	0.044
040	16241-05140	PLATE B/THER ELEMENT	1				0.005	0.011
050	16241-05150	PLATE B/THER ELEMENT	1				0.01	0.022
060	16241-05670	ELEMENT BREATHER	1				0.01	0.022
070	16241-05370	OIL SHIELD BREATHER	1				0.01	0.022
080	03024-50510	SCREW WITH WASHER	2				0.002	0.0044
090	15952-92330	NUT CAP	3				0.01	0.022
100	15951-96660	GASKET	3				0.001	0.0022
110	15221-33140	PLUG OIL FILLER	1	≤325640			0.038	0.0836
110	15852-33140	PLUG OIL FILLER	1	≥325641	↔		0.038	0.0836
120	04814-50300	O RING	1				0.001	0.0022
130	16241-05510	PIPE BREATHER	1				0.06	0.132