

Instructions for Parts Books

The heading at the top of the page will be the same for the picture of the parts at it is for the page with the part numbers.

Definition of column headings on part number pages:

REF.No → The number referring to the part on the picture page of the parts book.

Part No. → The number assigned to this part at the time of printing the parts book.

Description → Discription of part.

Q'ty → Quantity of part used on that page.

S.No. → Serial number range of the equipment that this part will fit.

>= Your serial number should be greater than or equal to the number shown.

<= Your serial number should be lesser than or equal to the serial number shown.

I/C → Interchangeability of part shown.

↔ The part shown will work for the older and later serial number.

The part shown is not interchangeable with the other serial number.

← new for old

→ old for new

Remarks → Notes about this particulart part. Sometimes this may say except [FR] or [CA]

Note about Country Codes:

The parts books we use in the United States of America may also contain information about a part that would be different in another country. It is important that you are aware of the country codes in some instances.

Symbol	Country
A	United States of America
CA	Canada
FR	France
GR	Greece
PO	Portugal
AU	Australia

If the remarks column says for example EXCEPT [FR] this part works in all countries except France. That means it will work here in the USA.

**ALL PRODUCT INDEX
KX41-2(S SERIES)**

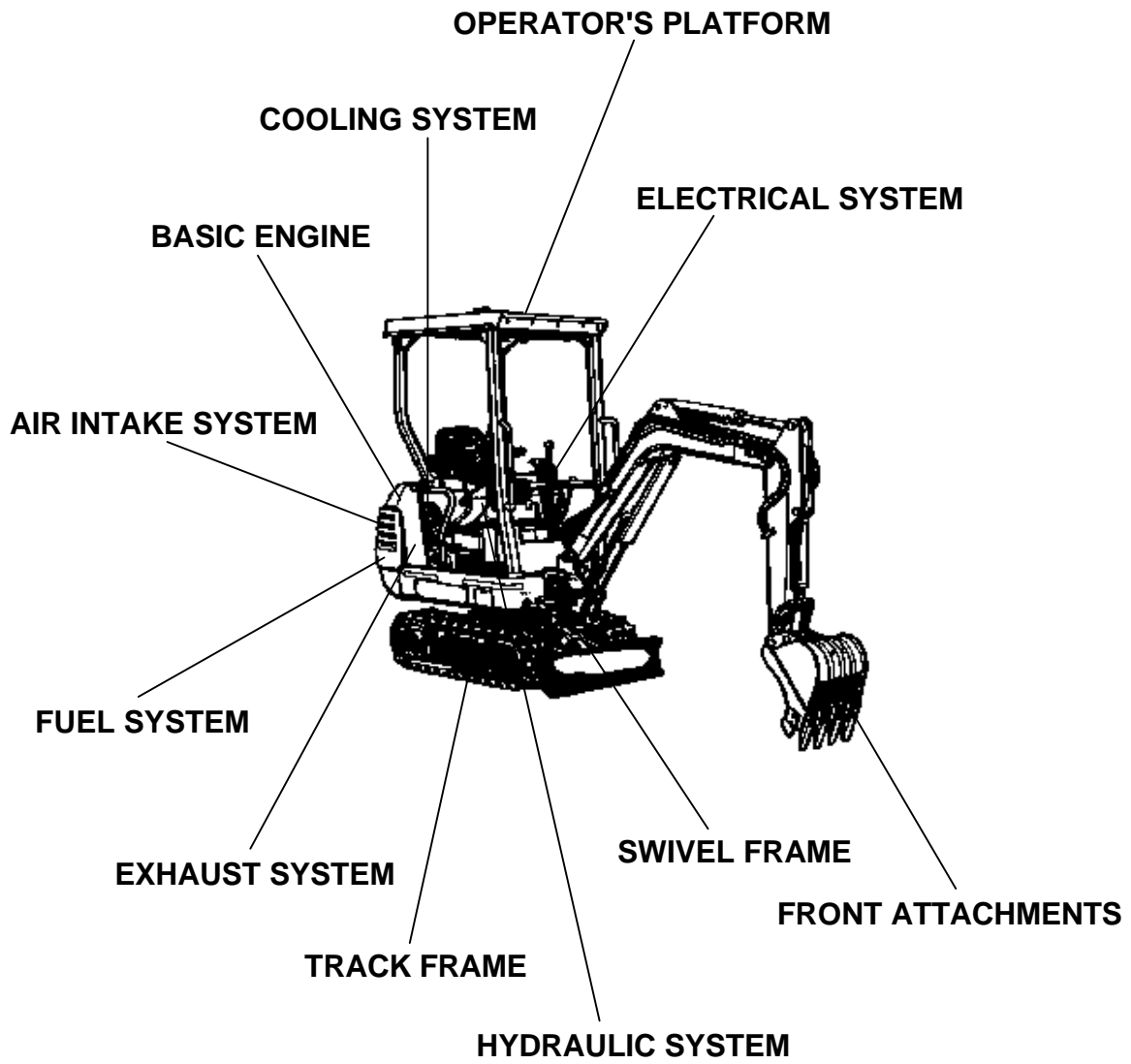

ACCESSORIES

Item	Part No.	Description	Book
BASIC ENGINE	01S001	CRANKCASE	100K0537
	01S002	OIL PAN	100K0537
	01S003	PISTON,CRANKSHAFT	100K0537
	01S004	MAIN BEARING CASE	100K0537
	01S005	CAMSHAFT	100K0537
	01S006	CYLINDER HEAD	100K0537
	01S007	VALVE AND ROCKER ARM	100K0537
	01S008	HEAD COVER	100K0537
	01S009	GEAR CASE	100K0537
FUEL SYSTEM	01S013	NOZZLE HOLDER,GLOW PLUG	100K0537
	01S014	NOZZLE HOLDER [COMPONENT PARTS]	100K0537
	01S015	SPEED CONTROL PLATE	100K0537
	01S016	STOP SOLENOID	100K0537
	01S017	GOVERNOR	100K0537
	01S018	INJECTION PUMP	100K0537
	01S020	FUEL CAMSHAFT	100K0537
	01S025	WATER FLANGE	100K0537
COOLING SYSTEM	01S026	WATER PUMP	100K0537
	01S029	FLYWHEEL,STARTER	100K0537
ELECTRICAL SYSTEM	01S030	STARTER [COMPONENT PARTS]	100K0537
	01S031	ALTERNATOR	100K0537
	01S032	ALTERNATOR [COMPONENT PARTS]	100K0537
BASIC ENGINE	02S010	ENGINE BRACKET	100K0537
AIR INTAKE SYSTEM	02S011	AIR CLEANER,INLET MANIFOLD	100K0537
EXHAUST SYSTEM	02S012	MUFFLER,EXHAUST MANIFOLD	100K0537
FUEL SYSTEM	02S021	ACCEL LEVER	100K0537
	02S022	FUEL PIPING	100K0537
	02S023	FUEL FILTER [COMPONENT PARTS]	100K0537
	02S024	FUEL TANK	100K0537
COOLING SYSTEM	02S027	RADIATOR	100K0537
	02S028	WATER PIPE	100K0537
ELECTRICAL SYSTEM	02S033	BATTERY	100K0537
	02S034	TIMER,HORN	100K0537
	02S035	SWITCH,METER	100K0537
	02S036	LIGHT	100K0537
HYDRAULIC SYSTEM	02S037	ELECTRICAL WIRING	100K0537
	02S038	PUMP HOUSING	100K0537
	02S039	GRAR PUMP AND COMPONENT PARTS	100K0537
	02S040	HYDRAULIC PUMP AND COMPONENT PARTS	100K0537
	02S041-1	DRIVE MOTOR AND COMPONENT PARTS (1)	100K0537
	02S041-2	DRIVE MOTOR AND COMPONENT PARTS (2)	100K0537
	02S042	SWIVEL MOTOR AND COMPONENT PARTS	100K0537
	02S043-1	ROTARY JOINT	100K0537
	02S043-2	ROTARY JOINT [KX41-2V]	100K0537
	02S044	OIL TANK	100K0537
	02S045-1	CONTROL VALVE	100K0537
	02S045-2	CONTROL VALVE [KX41-2V]	100K0537
	02S046	CONTROL VALVE [COMPONENT PARTS]	100K0537
	02S047	SPOOL SECTION (BOOM)	100K0537
	02S048	SPOOL SECTION (BUCKET)	100K0537
	02S049	SPOOL SECTION (TRAVL RH)	100K0537
	02S050	SPOOL SECTION (TRAVEL STRAIGHT)	100K0537
	02S051	SPOOL SECTION (S/P)	100K0537
	02S052	SPOOL SECTION (TRAVEL LH)	100K0537
02S053	SPOOL SECTION (ARM)	100K0537	
02S054	SPOOL SECTION (SPACER/SWING)	100K0537	
02S055	SPOOL SECTION (BLADE)	100K0537	
02S056	SPOOL SECTION (SWIVEL)	100K0537	
02S057	UNLOADER VALVE	100K0537	

Item	Part No.	Description	Book
HYDRAULIC SYSTEM	02S058	UNLOADER VALVE [COMPONENT PARTS]	100K0537
	02S059	TPSS VALVE	100K0537
	02S060	TPSS VALVE [COMPONENT PARTS]	100K0537
	02S061	CHANGE VALVE [KX41-2V]	100K0537
	02S062	CHANGE VALVE [COMPONENT PARTS] [KX41-2V]	100K0537
	02S063	CONTROL LEVER (FRAME)	100K0537
	02S064	CONTROL LEVER (LEVER LH)	100K0537
	02S065	CONTROL LEVER (LEVER RH)	100K0537
	02S066	PILOT VALVE [COMPONENT PARTS]	100K0537
	02S067	CONTROL LEVER (TRAVEL LH)	100K0537
	02S068	CONTROL LEVER (TRAVEL RH)	100K0537
	02S069	CONTROL TRAVEL PEDAL	100K0537
	02S070	CONTROL LEVER (SAFETY LOCK LEVER)	100K0537
	02S071	CONTROL PEDAL (SWIVEL/SWING CHANGE)	100K0537
	02S072	CONTROL LEVER (TPSS)	100K0537
	02S073	CONTROL LEVER (BLADE)	100K0537
	02S074	CONTROL LEVER (S/P 1)	100K0537
	02S075	CONTROL LEVER (S/P 2)	100K0537
	02S076	OIL PIPING (SUCTION,DELIVERY)	100K0537
	02S077	OIL PIPING (OIL RETURN)	100K0537
	02S078	OIL PIPING (OIL COOLER)	100K0537
	02S079-1	OIL PIPING (TRAVEL LH)	100K0537
	02S079-2	OIL PIPING (TRAVEL LH) [KX41-2V]	100K0537
	02S080-1	OIL PIPING (TRAVEL RH)	100K0537
	02S080-2	OIL PIPING (TRAVEL RH) [KX41-2V]	100K0537
	02S081	OIL PIPING (SWIVEL 1)	100K0537
	02S082	OIL PIPING (SWIVEL 2)	100K0537
	02S083	OIL PIPING (SWING)	100K0537
	02S084	OIL PIPING (LOOK)	100K0537
	02S085	OIL PIPING (BOOM 1)	100K0537
	02S086	OIL PIPING (BOOM 2)	100K0537
	02S087	OIL PIPING (ARM 1)	100K0537
	02S088	OIL PIPING (ARM 2)	100K0537
	02S089	OIL PIPING (BUCKET 1)	100K0537
	02S090	OIL PIPING (BUCKET 2)	100K0537
	02S091-1	OIL PIPING (BLADE)	100K0537
	02S091-2	OIL PIPING (BLADE) [KX41-2V]	100K0537
	02S092	OIL PIPING (TRACK) [KX41-2V]	100K0537
	02S093	OIL PIPING (CLAMP)	100K0537
	02S094	OIL PIPING (S/P)	100K0537
	02S095	BOOM CYLINDER AND COMPONENT PARTS	100K0537
	02S096	ARM CYLINDER AND COMPONENT PARTS	100K0537
	02S097	BUCKET CYLINDER AND COMPONENT PARTS	100K0537
	02S098-1	BLADE CYLINDER AND COMPONENT PARTS	100K0537
	02S098-2	BLADE CYLINDER AND COMPONENT PARTS [KX41-2V]	100K0537
02S099	SWING CYLINDER AND COMPONENT PARTS	100K0537	
FRONT ATTACHMENTS	02S100	TRACK CYLINDER AND COMPONENT PARTS [KX41-2V]	100K0537
	02S101	SWING BRACKET	100K0537
	02S102	BOOM	100K0537
	02S103	CYLINDER COVER (BOOM)	100K0537
	02S104	ARM	100K0537
	02S105	BUCKET LINK	100K0537
TRACK FRAME	02S106	BUCKET	100K0537
	02S107-1	BLADE	100K0537
	02S107-2	BLADE [KX41-2V]	100K0537
	02S108-1	TRACK FRAME	100K0537
	02S108-2	TRACK FRAME [KX41-2V]	100K0537
02S109-1	IDLER	100K0537	
02S109-2	IDLER [KX41-2V]	100K0537	

Item	Part No.	Description	Book
TRACK FRAME	02S110-1	TRACK ROLLER	100K0537
	02S110-2	TRACK ROLLER [KX41-2V]	100K0537
SWIVEL FRAME	02S111	CRAWLER	100K0537
	02S112	SWIVEL FRAME	100K0537
	02S113	ARCH FRAME	100K0537
	02S114	SWIVEL BEARING	100K0537
	02S115	STEP	100K0537
	02S116	COVER (LEFT)	100K0537
	02S117	BONNET	100K0537
	02S118	SPONGE (1)	100K0537
	02S119	SPONGE (2)	100K0537
OPERATOR'S PLATFORM	02S120	WEIGHT	100K0537
	02S121	CANOPY	100K0537
	02S122	INSTRUMENT PANEL	100K0537
	02S123	SEAT	100K0537
	02S124	LABEL	100K0537
ACCESSORIES	02S125	ACCESSORIES	100K0537
	02S126	WEIGHT KIT [OPTION]	100K0537
	02S127	LABEL KIT [OPTION]	100K0537

CRANKCASE

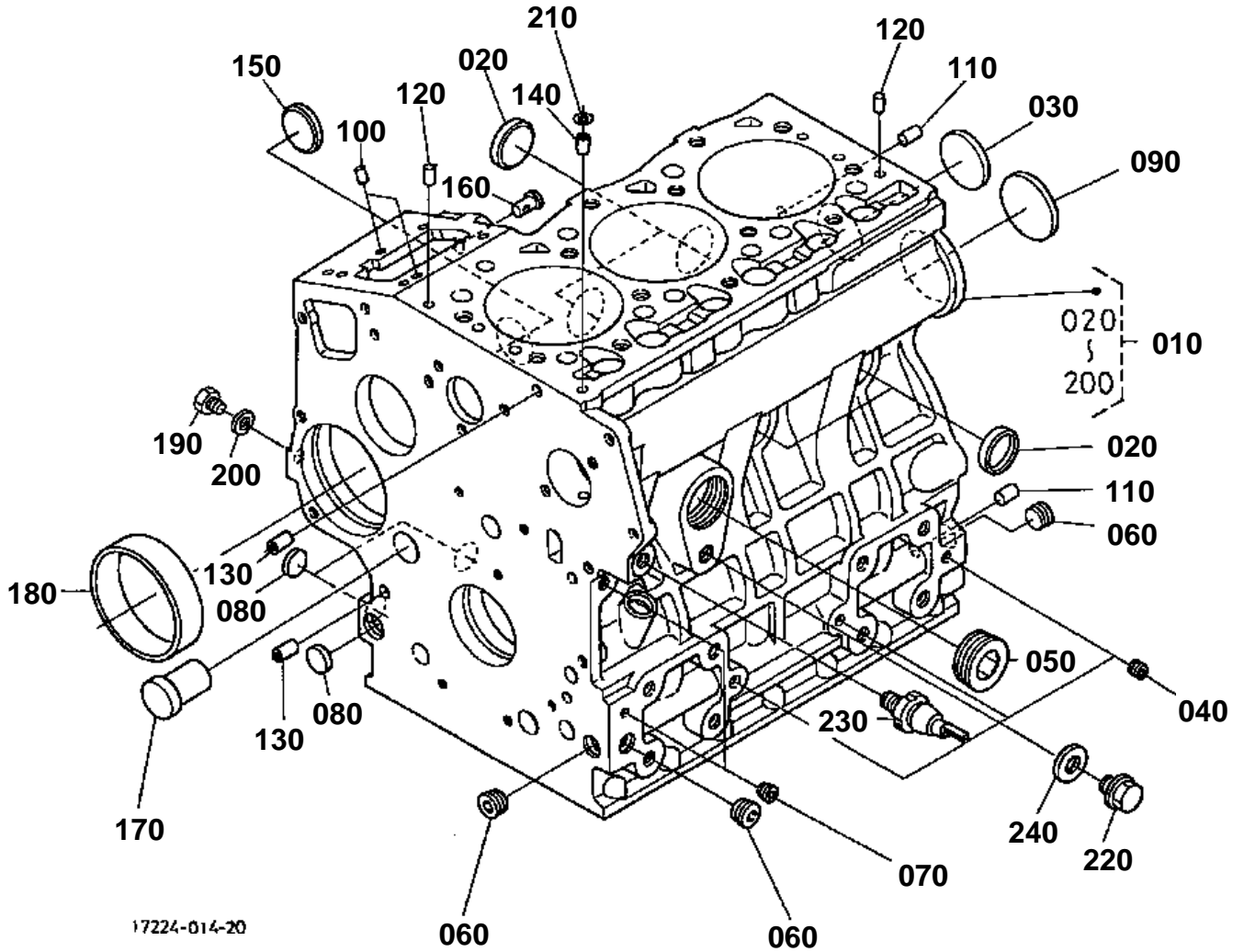



CRANKCASE

↔ Interchangeable; ≠ not interchangeable; ← new for old; → old for new

REF.No	Part No.	Description	Q'ty	S.No.	I/C	REMARKS	Weight (kgf)	Weight (lb)
010	16613-01012	COMP.CRANKCASE	1	<=YB0607			0	0
010	16613-01013	COMP.CRANKCASE	1	>=YC0001	←		32	70.4
010	16613-01014	COMP.CRANKCASE	1	>=YL0001	←		32	70.4
010	16613-01016	COMP.CRANKCASE	1	>=1G0001	←		0	0
020	15451-96270	CAP SEALING	4				0.012	0.0264
030	15221-03490	CAP SEALING	1				0.02	0.044
040	15261-96010	PLUG	3				0.002	0.0044
050	16683-96020	PLUG	1				0.47	1.034
060	16241-96010	PLUG	3				0.007	0.0154
070	15521-96020	PLUG	2				0.003	0.0066
080	17391-96160	PLUG EXPANSION	3				0.003	0.0066
090	16271-96160	PLUG EXPANSION	1				0.025	0.055
100	16225-94510	PIN STRAIGHT	2				0.001	0.0022
110	16221-94530	PIN STRAIGHT	2				0.006	0.0132
120	16221-94520	PIN STRAIGHT	2				0.005	0.011
130	15231-33960	PIN PIPE	2				0.001	0.0022
140	16241-33650	PIN PIPE	1				0.002	0.0044
150	16241-96262	PLUG FUEL CAMSHAFT	1				0.007	0.0154
160	16261-56280	PIN START SPRING	1				0.004	0.0088
170	16282-96010	PLUG	1				0.09	0.198
180	16271-55350	BUSH GOVERNOR GEAR	1				0.06	0.132
190	15221-33610	PLUG	1				0.009	0.0198
200	15021-33660	GASKET	1				0.001	0.0022
210	15221-33700	O RING	1				0.001	0.0022
220	06311-55020	PLUG	1				0.031	0.0682
230	15531-39010	SWITCH OIL	1				0.032	0.0704
240	04714-00200	GASKET	1				0.002	0.0044

OIL PAN

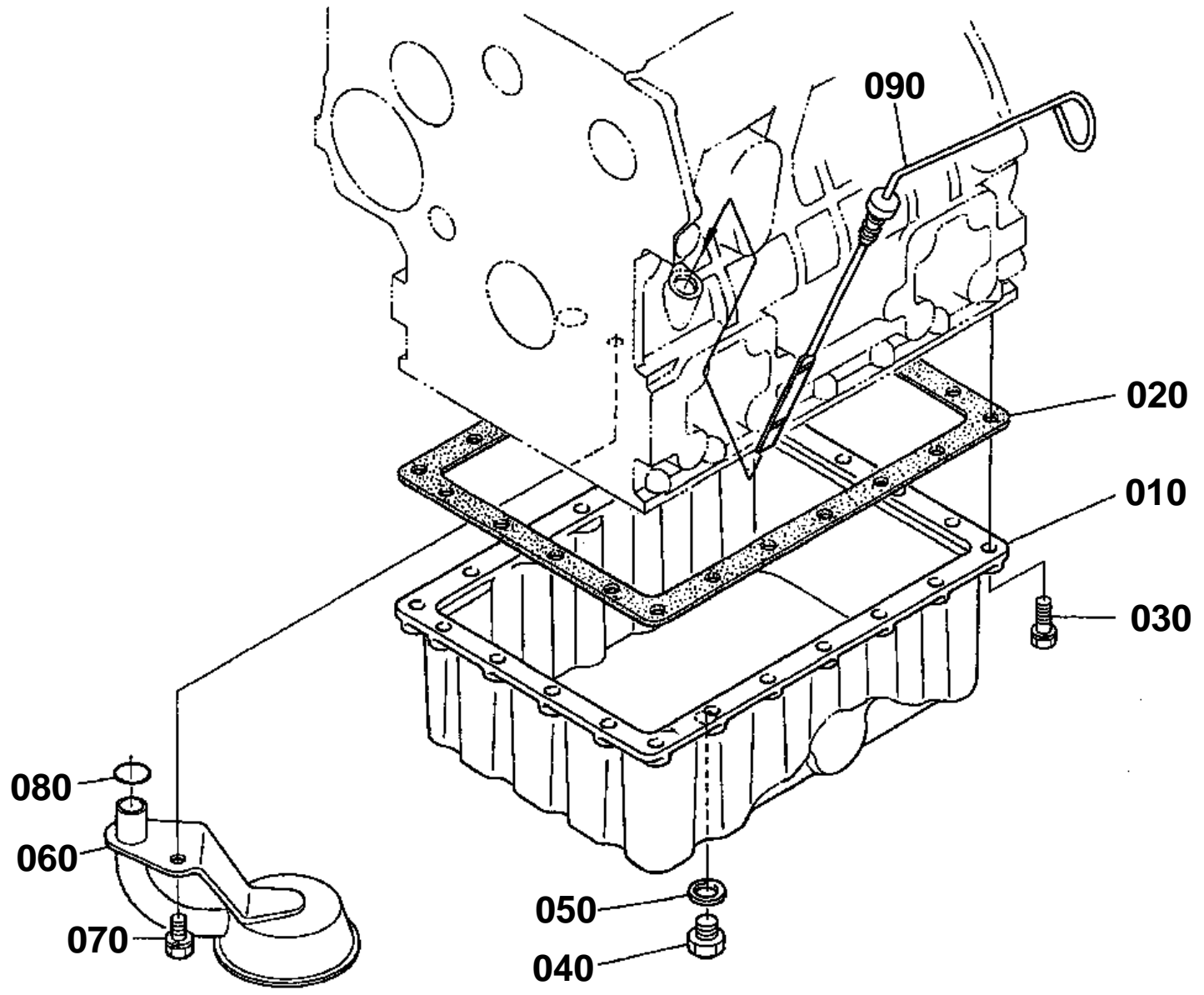

16215-001-10



OIL PAN

↔ Interchangeable; ≠ not interchangeable; ← new for old; → old for new

REF.No	Part No.	Description	Q'ty	S.No.	I/C	REMARKS	Weight (kgf)	Weight (lb)
010	16215-01610	OIL PAN	1				4.06	8.932
020	16261-01630	GASKET OIL PAN	1				0.001	0.0022
030	01023-50618	BOLT	22				0.006	0.0132
040	15221-33750	PLUG	1				0.032	0.0704
050	6C090-58960	GASKET	1				0.002	0.0044
060	16261-32114	FILTER OIL	1				0.21	0.462
070	01123-60816	BOLT	1				0.01	0.022
080	04814-00160	O RING	1				0.001	0.0022
090	16215-36412	GAUGE OIL	1				0.042	0.0924

PISTON,CRANKSHAFT

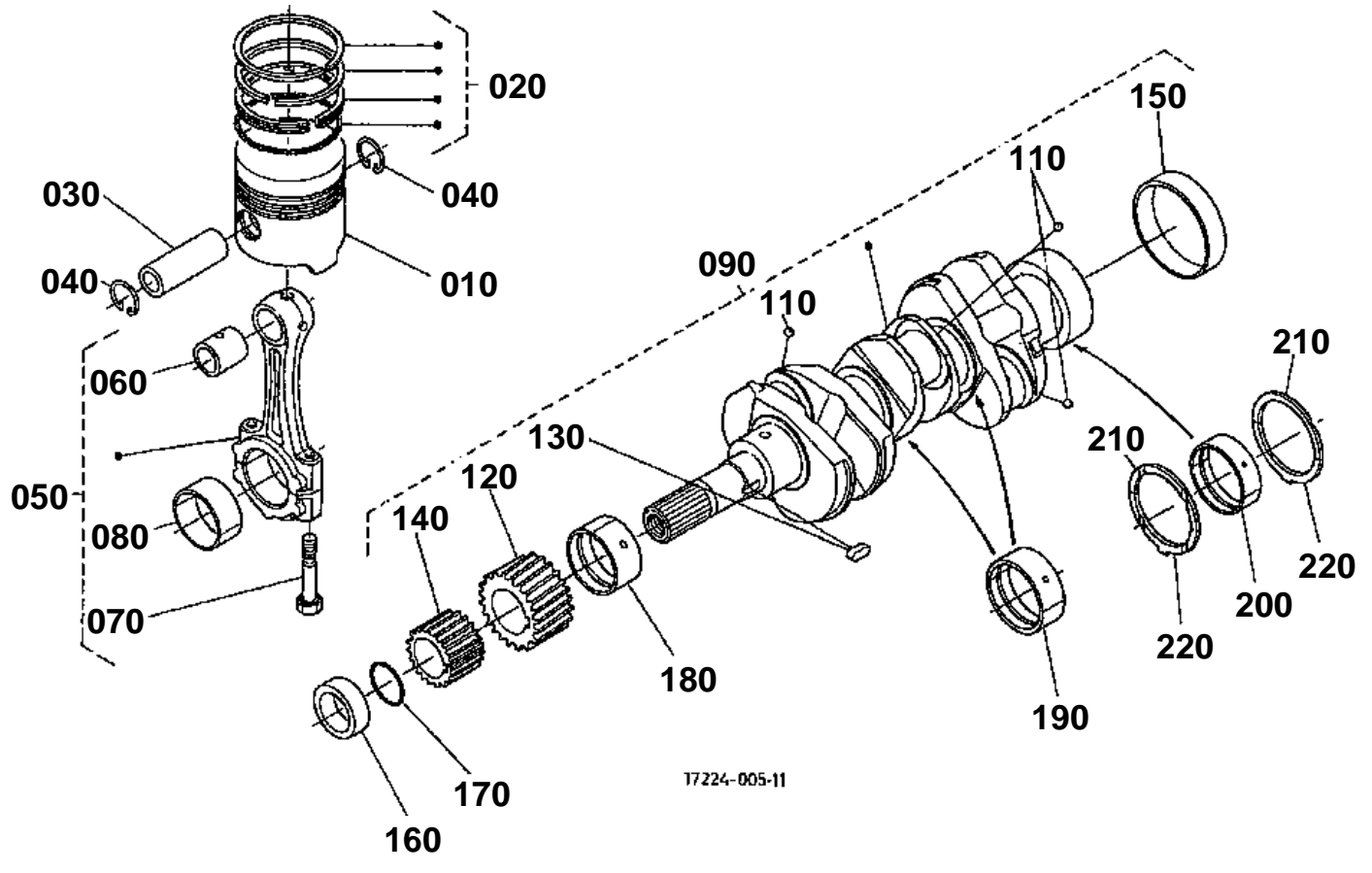

17224-005-11



PISTON,CRANKSHAFT

↔ Interchangeable; ≠ not interchangeable; ← new for old; → old for new

REF.No	Part No.	Description	Q'ty	S.No.	I/C	REMARKS	Weight (kgf)	Weight (lb)
010	16060-21110	PISTON	3			STD	0.4	0.88
010	16060-21910	PISTON	3			+0.5mm	0.415	0.913
020	16261-21050	ASSY PISTON RING	3			STD	0.042	0.0924
020	16261-21090	ASSY PISTON RING	3			+0.5mm	0.05	0.11
030	16241-21310	PIN PISTON	3				0.135	0.297
040	16241-21330	CIR CLIP PISTON PIN	6				0.002	0.0044
050	16241-22012	ASSY ROD CONNECTING	3				0.545	1.199
060	16241-21980	BUSH PISTON PIN	3				0.03	0.066
070	16241-22142	BOLT CONNECTING ROD	6				0	0
080	16241-22310	METAL CRANKPIN	3			STD SET	0.038	0.0836
080	16241-22970	METAL CRANKPIN	3			-0.2mm SET	0.08	0.176
080	16241-22980	METAL CRANKPIN	3			-0.4mm SET	0.1	0.22
090	16265-23013	COMP.CRANKSHAFT	1				8.2	18.04
100	99999-99999	BLANK	0				0	0
110	07715-00401	BALL	3				0.001	0.0022
120	16241-24110	GEAR CRANK	1				0.15	0.33
130	16271-95230	KEY	1				0.005	0.011
140	16241-35630	GEAR OIL PUMP DRIVE	1				0.102	0.2244
150	16241-23280	SLEEVE CRANKSHAFT	1				0.06	0.132
160	16241-23250	COLLAR CRANKSHAFT	1				0.05	0.11
170	04814-10280	O RING	1				0.001	0.0022
180	16241-23470	METAL CRANKSHAFT	1			STD	0.06	0.132
180	16241-23910	METAL CRANKSHAFT	1			-0.2mm	0.03	0.066
180	16241-23920	METAL CRANKSHAFT	1			-0.4mm	0.068	0.1496
190	16241-23480	METAL CRANKSHAFT	2			STD SET	0.05	0.11
190	16241-23930	METAL CRANKSHAFT	2			-0.2mm SET	0.1	0.22
190	16241-23940	METAL CRANKSHAFT	2			-0.4mm SET	0.05	0.11
200	16292-23490	METAL CRANKSHAFT	1			STD SET	0.07	0.154
200	16292-23860	METAL CRANKSHAFT	1			-0.2mm SET	0.05	0.11
200	16292-23870	METAL CRANKSHAFT	1			-0.4mm SET	0.05	0.11
210	15521-23530	METAL SIDE	2			STD	0.01	0.022
210	15521-23950	METAL SIDE	2			+0.2mm	0.01	0.022
210	15521-23960	METAL SIDE	2			+0.4mm	0.01	0.022
220	19202-23540	METAL SIDE	2			STD	0.01	0.022
220	19202-23970	METAL SIDE	2			+0.2mm	0.01	0.022
220	19202-23980	METAL SIDE	2			+0.4mm	0.01	0.022

MAIN BEARING CASE

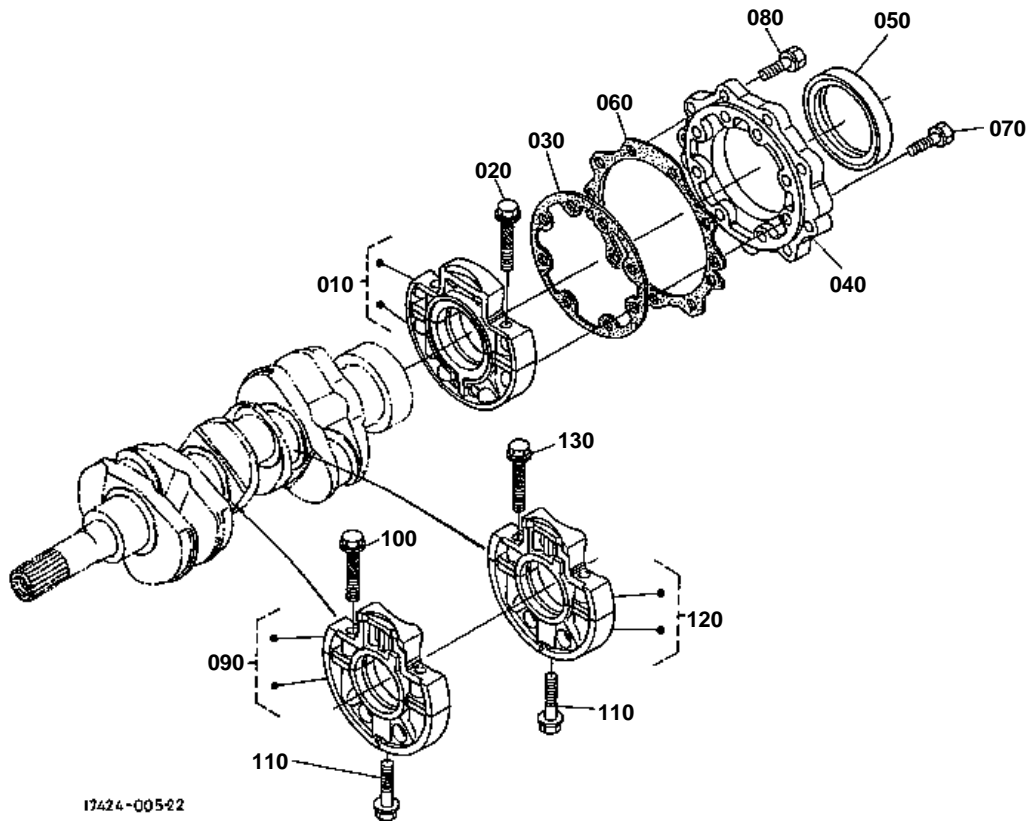

17424-005-22



MAIN BEARING CASE

↔ Interchangeable; ≠ not interchangeable; ← new for old; → old for new

REF.No	Part No.	Description	Q'ty	S.No.	I/C	REMARKS	Weight (kgf)	Weight (lb)
010	16241-04092	ASSY CASE MAIN BRG.	1				1.13	2.486
020	16241-04540	BOLT BEARING CASE	2				0.02	0.044
030	16264-04360	GASKET BRG.CASE	1				0.002	0.0044
040	16241-04813	COVER BEARING CASE	1				0.22	0.484
050	16241-04460	SEAL OIL	1				0.02	0.044
060	16264-04820	GASKET	1				0.008	0.0176
070	01023-50625	BOLT	8				0.007	0.0154
080	01023-50620	BOLT	9				0.006	0.0132
090	16261-04040	ASSY CASE MAIN BRG.	1				0.9	1.98
100	16241-04540	BOLT BEARING CASE	2				0.02	0.044
110	16241-04560	BOLT BEARING CASE	2				0.03	0.066
120	16261-04050	ASSY CASE MAIN BRG.	1				1.11	2.442
130	16241-04540	BOLT BEARING CASE	2				0.02	0.044

CAMSHAFT

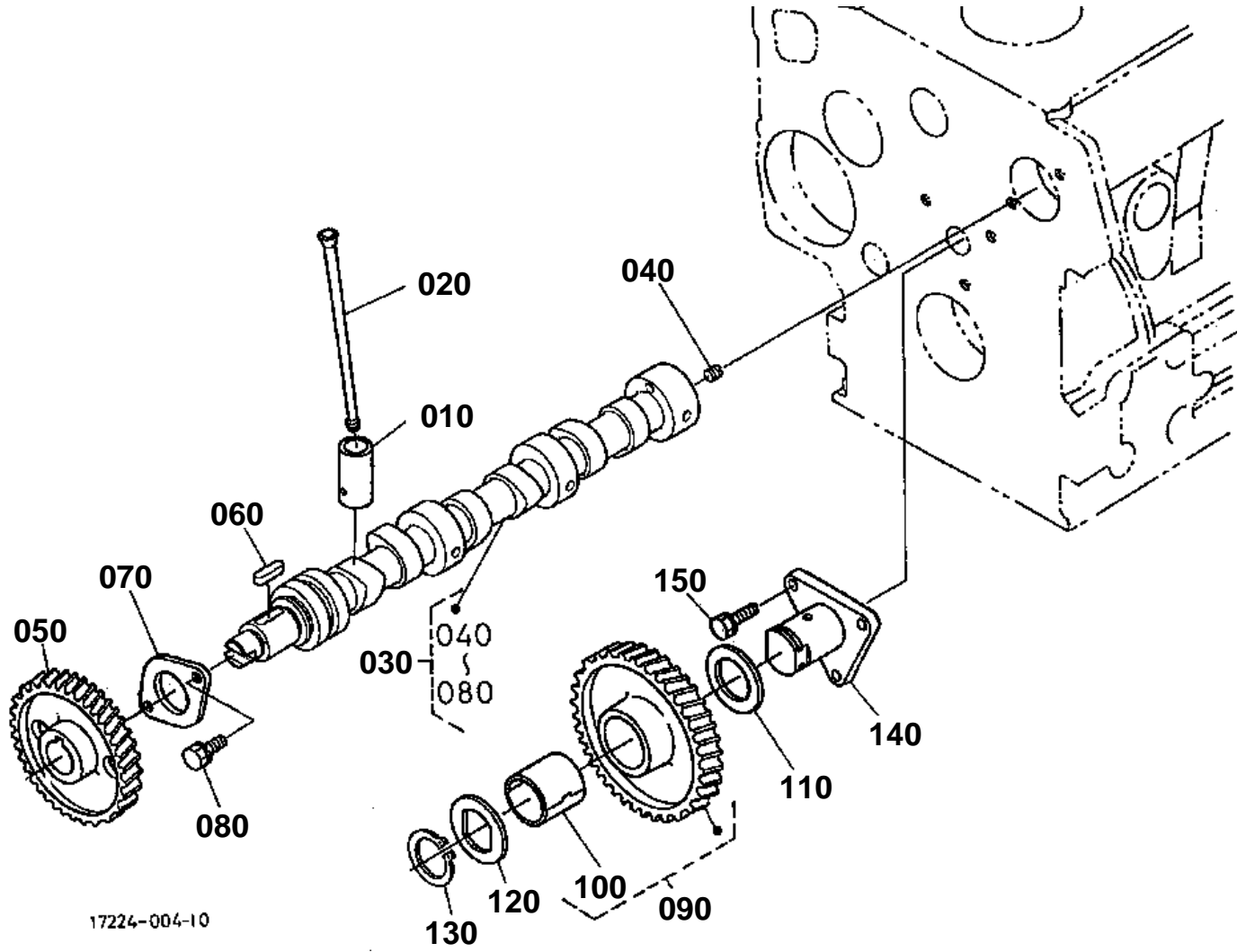



CAMSHAFT

↔ Interchangeable; ≠ not interchangeable; ← new for old; → old for new

REF.No	Part No.	Description	Q'ty	S.No.	I/C	REMARKS	Weight (kgf)	Weight (lb)
010	16261-15550	TAPPET	6				0.035	0.077
020	16241-15110	PUSH ROD	6				0.03	0.066
030	16261-16010	ASSY CAMSHAFT	1				1.7	3.74
040	15521-93610	SCREW SET	1				0.002	0.0044
050	16241-16510	GEAR CAM	1				0.45	0.99
060	05712-00518	KEY FEATHER	1				0.003	0.0066
070	16241-16270	STOPPER CAMSHAFT	1				0.04	0.088
080	01023-50614	BOLT	2	≤2D0119			0.005	0.011
080	01023-50616	BOLT	2	≥2E0001	←		0.005	0.011
090	16271-24010	COMP GEAR IDLE	1				0.6	1.32
100	16271-24980	BUSH IDLE GEAR	1				0.02	0.044
110	16241-24360	COLLAR IDLE GEAR	1				0.01	0.022
120	16241-24370	COLLAR IDLE GEAR	1				0.012	0.0264
130	16241-24320	CIR CLIP IDLE GEAR	1				0.003	0.0066
140	16241-24250	SHAFT IDLE GEAR	1				0.255	0.561
150	01023-50616	BOLT	3				0.005	0.011

CYLINDER HEAD

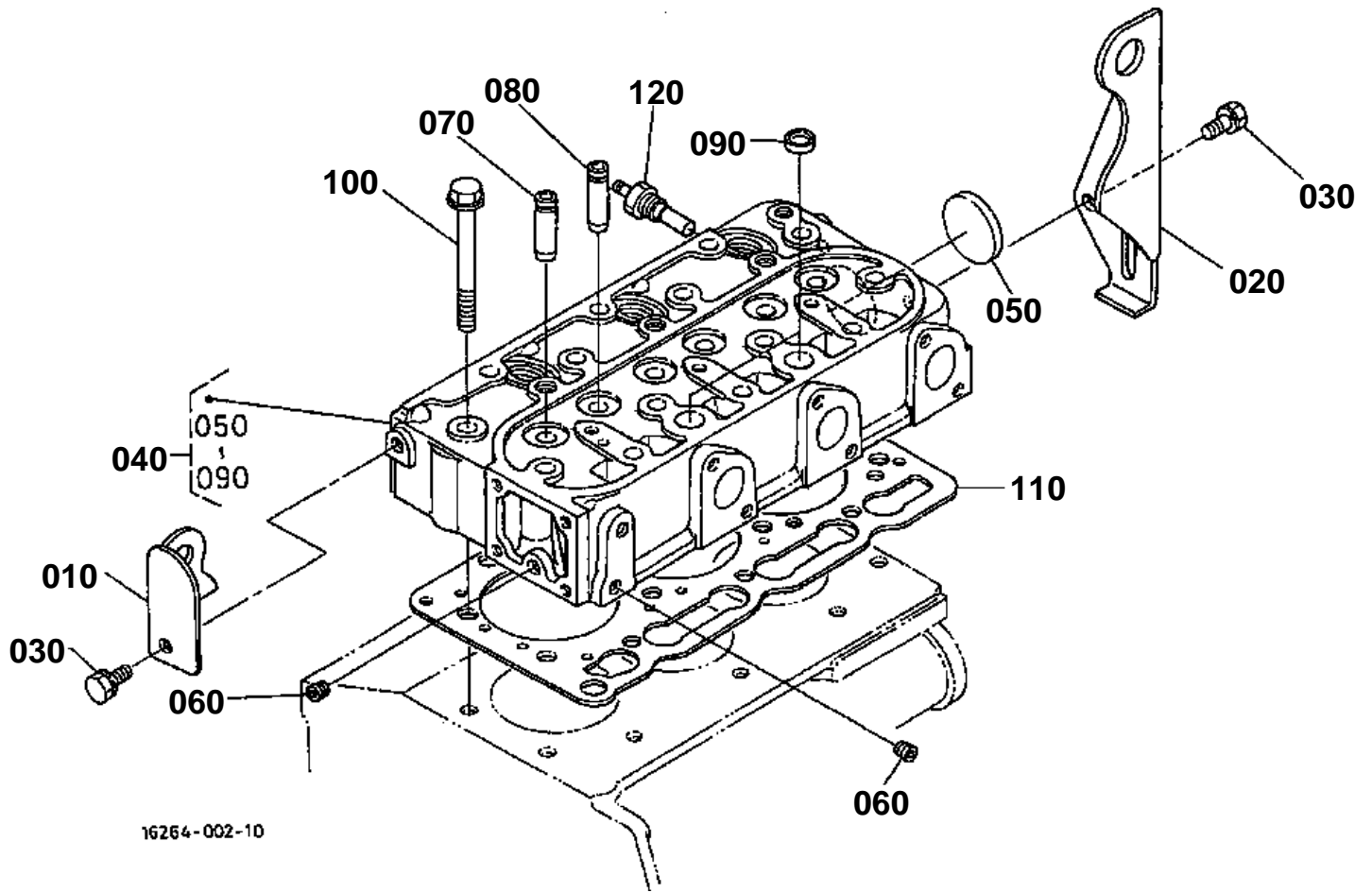

16264-002-10



CYLINDER HEAD

↔ Interchangeable; ≠ not interchangeable; ← new for old; → old for new

REF.No	Part No.	Description	Q'ty	S.No.	I/C	REMARKS	Weight (kgf)	Weight (lb)
010	16241-01750	HOOK ENGINE	1				0.08	0.176
020	16241-01770	HOOK ENGINE	1				0.175	0.385
030	01123-60814	BOLT	2				0.01	0.022
040	16032-03042	COMP.CYLINDER HEAD	1				9.2	20.24
050	15321-96260	CAP SEALING	1				0.014	0.0308
060	15261-96010	PLUG	2				0.002	0.0044
070	16241-13540	GUIDE INLET VALVE	3				0.02	0.044
080	16241-13560	GUIDE EXHAUST VALVE	3				0.01	0.022
090	15261-03370	CAP SEALING	2				0.005	0.011
100	16241-03450	BOLT CYLINDER HEAD	14				0.07	0.154
110	1E038-03310	GASKET CYL.HEAD	1				0.07	0.154
120	31351-32830	SENSOR THERMO	1				0.02	0.044

VALVE AND ROCKER ARM

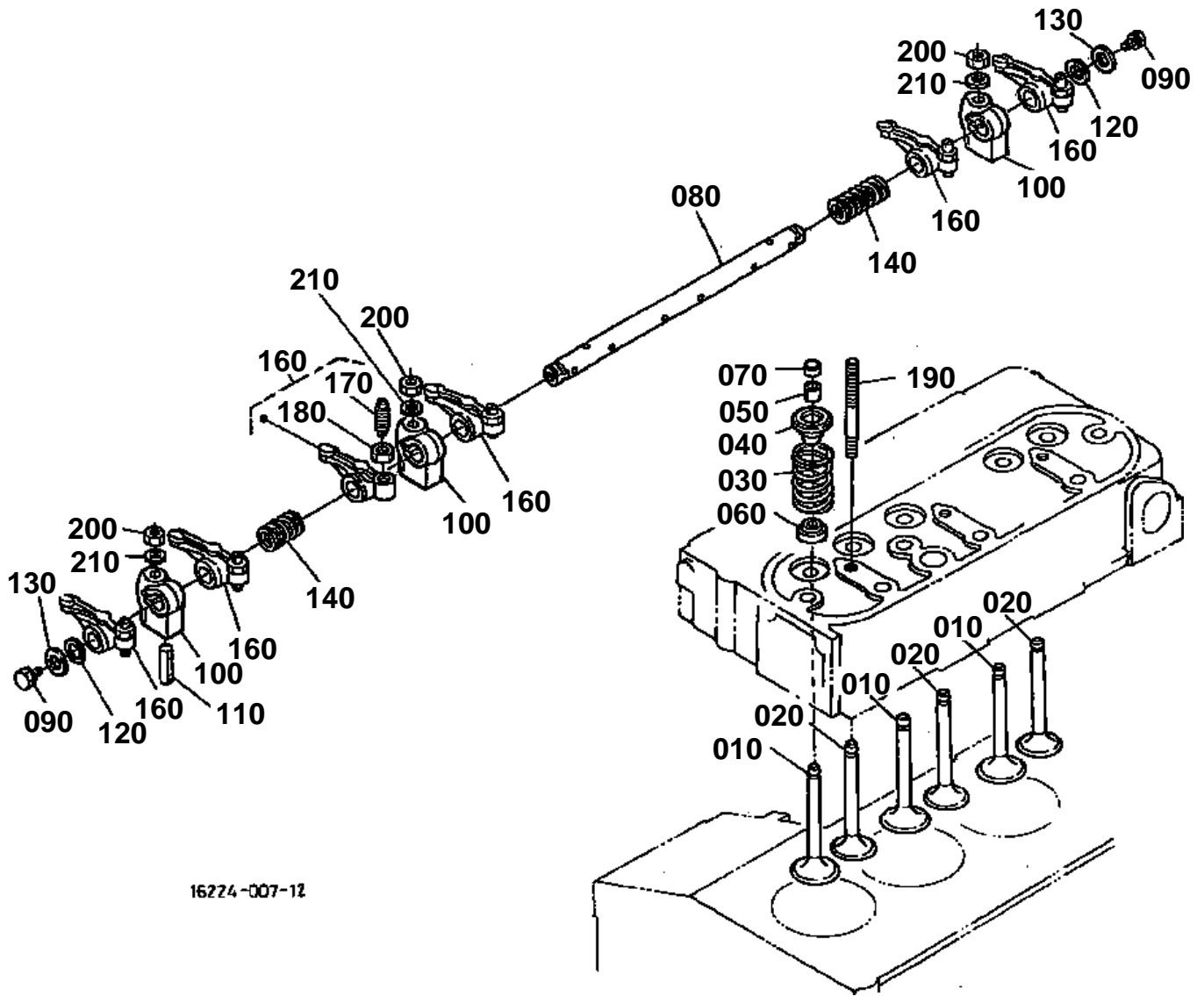

16224-007-12



VALVE AND ROCKER ARM

↔ Interchangeable; ≠ not interchangeable; ← new for old; → old for new

REF.No	Part No.	Description	Q'ty	S.No.	I/C	REMARKS	Weight (kgf)	Weight (lb)
010	16241-13110	VALVE INLET	3				0.05	0.11
020	16241-13120	VALVE EXHAUST	3				0.045	0.099
030	16271-13240	SPRING VALVE	6				0.015	0.033
040	16241-13330	RETAINER VALVE SP.	6				0.015	0.033
050	15261-13360	COLLET VALVE SPRING	6			SET	0.001	0.0022
060	1C010-13150	SEAL VALVE STEM	6				0.002	0.0044
070	16241-13280	CAP VALVE	6				0.005	0.011
080	16261-14264	SHAFT ROCKER ARM	1				0.16	0.352
090	01023-50610	BOLT	2				0.005	0.011
100	16241-14350	BRACKET ROCKER ARM	3				0.04	0.088
110	05411-00428	PIN SPRING	1				0.002	0.0044
120	16241-14430	WASHER R-ARM.SHAFT	2				0.002	0.0044
130	15841-94022	WASHER PLAIN	2				0.005	0.011
140	16241-14310	SPRING ROCKER ARM	2				0.004	0.0088
150	99999-99999	BLANK	0				0	0
160	16241-14032	ASSY ROCKER ARM	6				0.052	0.1144
170	16241-14230	SCREW ADJUSTING	6				0.008	0.0176
180	16241-14240	NUT	6				0.004	0.0088
190	16241-14410	STUD	3				0.022	0.0484
200	15261-92010	NUT	3				0.005	0.011
210	15261-94010	WASHER PLAIN	3				0.002	0.0044

HEAD COVER

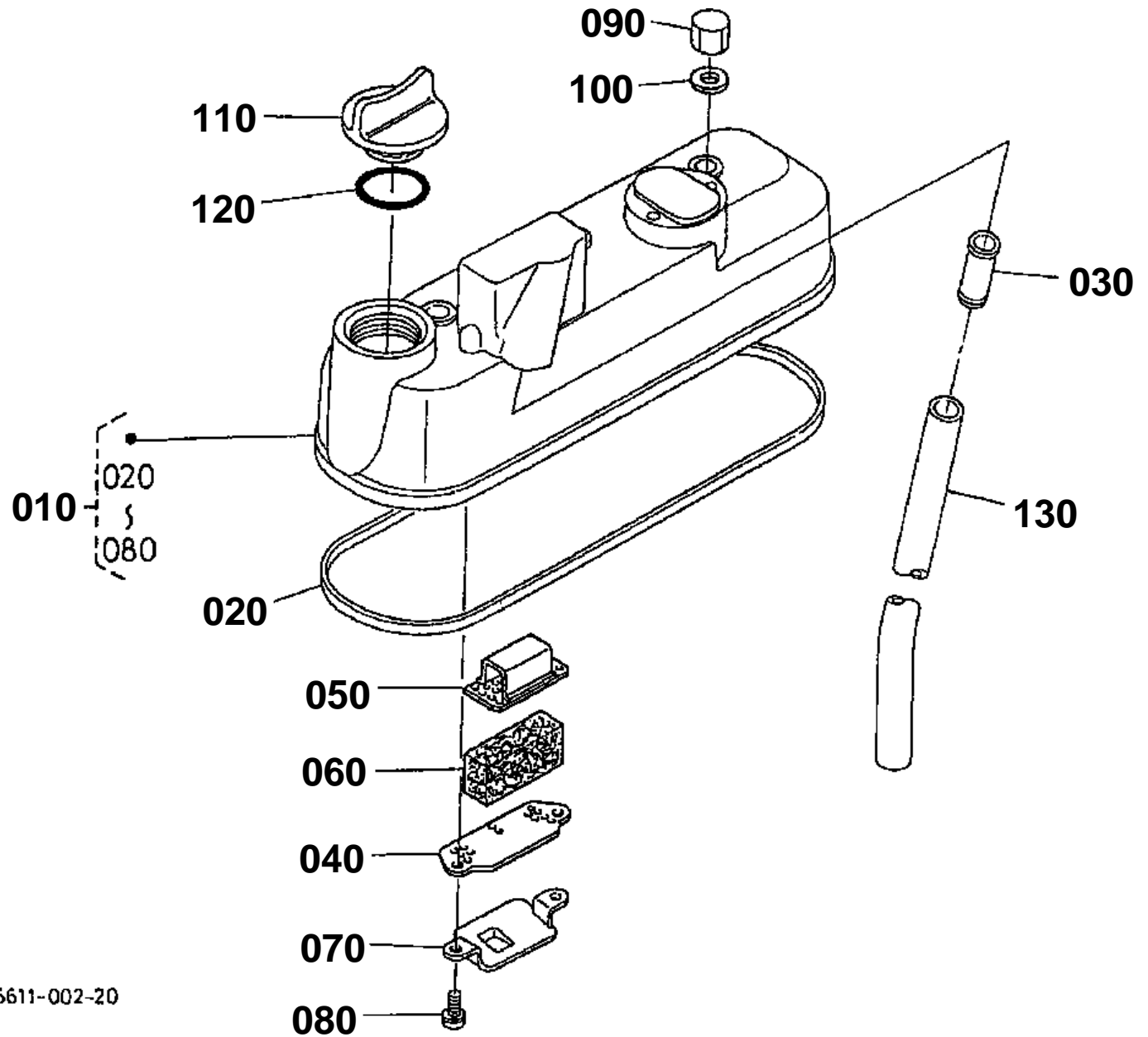

16611-002-20