

## Instructions for Parts Books

The heading at the top of the page will be the same for the picture of the parts at it is for the page with the part numbers.

Definition of column headings on part number pages:

**REF.No** → The number referring to the part on the picture page of the parts book.

**Part No.** → The number assigned to this part at the time of printing the parts book.

**Description** → Discription of part.

**Q'ty** → Quantity of part used on that page.

**S.No.** → Serial number range of the equipment that this part will fit.

>= Your serial number should be greater than or equal to the number shown.

<= Your serial number should be lesser than or equal to the serial number shown.

**I/C** → Interchangeability of part shown.

↔ The part shown will work for the older and later serial number.

# The part shown is not interchangeable with the other serial number.

← new for old

→ old for new

**Remarks** → Notes about this particulart part. Sometimes this may say except [FR] or [CA]

### Note about Country Codes:

The parts books we use in the United States of America may also contain information about a part that would be different in another country. It is important that you are aware of the country codes in some instances.

Symbol	Country
A	United States of America
CA	Canada
FR	France
GR	Greece
PO	Portugal
AU	Australia

If the remarks column says for example EXCEPT [FR] this part works in all countries except France. That means it will work here in the USA.

ALL PRODUCT INDEX  
KX121-2

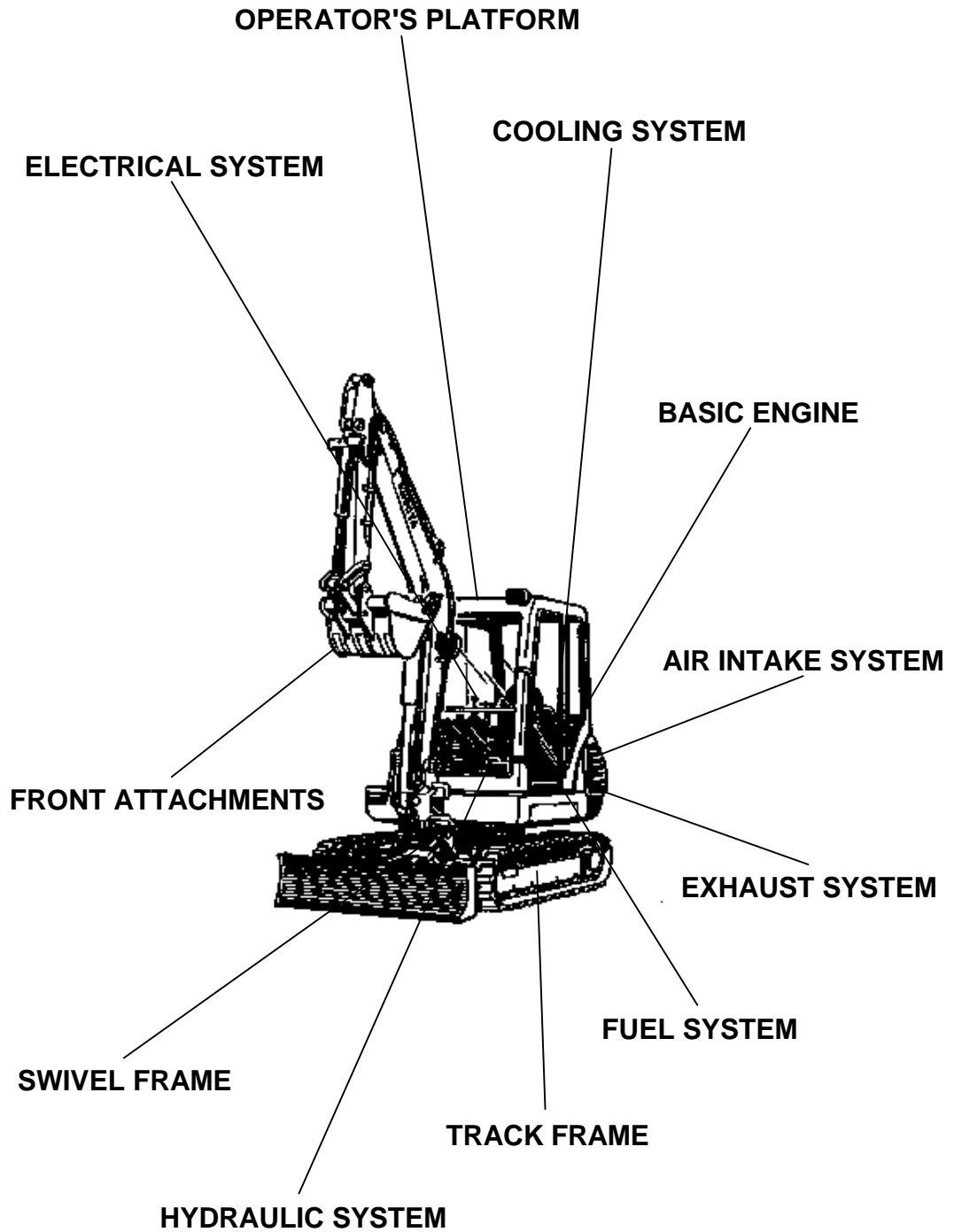

ACCESSORIES

Item	Part No.	Description	Book
BASIC ENGINE	01S001	CRANKCASE	100A0036
	01S002	OIL PAN	100A0036
	01S003	PISTON AND CRANKSHAFT	100A0036
	01S004	MAIN BEARING CASE	100A0036
	01S005	CAMSHAFT	100A0036
	01S006	CYLINDER HEAD	100A0036
	01S007	VALVE AND ROCKER ARM	100A0036
	01S008	CYLINDER HEAD COVER	100A0036
	01S009	GEAR CASE	100A0036
FUEL SYSTEM	01S013	NOZZLE HOLDER AND GLOW PLUG	100A0036
	01S014	SPEED CONTROL PLATE	100A0036
	01S015	ENGINE STOP LEVER	100A0036
	01S016	GOVERNOR	100A0036
	01S017	INJECTION PUMP	100A0036
	01S018	INJECTION PUMP [COMPONENT PARTS]	100A0036
	01S019	FUEL CAMSHAFT	100A0036
	COOLING SYSTEM	01S024	WATER FLANGE
01S025		WATER PUMP	100A0036
ELECTRICAL SYSTEM	01S028	FLYWHEEL,STARTER	100A0036
	01S029	STARTER [COMPONENT PARTS]	100A0036
	01S030	ALTERNATOR	100A0036
	01S031	ALTERNATOR [COMPONENT PARTS]	100A0036
BASIC ENGINE	02S010	ENGINE BRACKET	100A0036
AIR INTAKE SYSTEM	02S011	AIR CLEANER,INLET MANIFOLD	100A0036
EXHAUST SYSTEM	02S012	MUFFLER,EXHAUST MANIFOLD	100A0036
FUEL SYSTEM	02S020	ACCEL LEVER	100A0036
	02S021	FUEL PIPING	100A0036
	02S022	FUEL FILTER [COMPONENT PARTS]	100A0036
COOLING SYSTEM	02S023	FUEL TANK	100A0036
	02S026	RADIATOR	100A0036
	02S027	WATER PIPE	100A0036
ELECTRICAL SYSTEM	02S032	BATTERY	100A0036
	02S033	TIMER,HORN	100A0036
	02S034	SWITCH,METER	100A0036
	02S035	ELECTRICAL WIRING	100A0036
HYDRAULIC SYSTEM	02S036	PUMP HOUSING	100A0036
	02S037	PISTON PUMP AND COMPONENT PARTS	100A0036
	02S038	HYDRAULIC PUMP AND COMPONENT PARTS	100A0036
	02S039-1	DRIVE MOTOR AND COMPONENT PARTS (1)	100A0036
	02S039-2	DRIVE MOTOR AND COMPONENT PARTS (2)	100A0036
	02S040	SWIVEL MOTOR AND COMPONENT PARTS	100A0036
	02S041	ROTARY JOINT	100A0036
	02S042	OIL TANK	100A0036
	02S043	CONTROL VALVE	100A0036
	02S044	CONTROL VALVE [COMPONENT PARTS]	100A0036
	02S045-1	SPOOL SECTION (BUCKET/SWIVEL)	100A0036
	02S045-2	SPOOL SECTION (BOOM)	100A0036
	02S045-3	SPOOL SECTION (TRAVEL RH)	100A0036
	02S045-4	SPOOL SECTION (TRAVEL LH)	100A0036
	02S045-5	SPOOL SECTION (ARM)	100A0036
	02S045-6	SPOOL SECTION (S/P)	100A0036
	02S045-7	SPOOL SECTION (TRAVEL STRAIGHT)	100A0036
	02S045-8	SPOOL SECTION (SWING/BLADE)	100A0036
	02S046	CHANGE VALVE	100A0036
	02S047	CHANGE VALVE [COMPONENT PARTS]	100A0036
	02S048-1	MULTI VALVE	100A0036
02S048-2	TPSS VALVE	100A0036	
02S049-1	MULTI VALVE [COMPONENT PARTS]	100A0036	
02S049-2	TPSS VALVE [COMPONENT PARTS]	100A0036	

Item	Part No.	Description	Book	
HYDRAULIC SYSTEM	02S050	CONTROL LEVER (FRAME)	100A0036	
	02S051	CONTROL LEVER (LEVER LH)	100A0036	
	02S052	CONTROL LEVER (LEVER RH)	100A0036	
	02S053	PILOT VALVE [COMPONENT PARTS]	100A0036	
	02S054	CONTROL LEVER (TRAVEL LH)	100A0036	
	02S055	CONTROL LEVER (TRAVEL RH)	100A0036	
	02S056	CONTROL TRAVEL PEDAL	100A0036	
	02S057	CONTROL LEVER (SAFETY LOCK LEVER)	100A0036	
	02S058	CONTROL PEDAL (SWIVEL/SWING CHANGE)	100A0036	
	02S059-1	CONTROL LEVER (TPSS)	100A0036	
	02S059-2	CONTROL LEVER (TPSS)	100A0036	
	02S060	CONTROL LEVER (BLADE)	100A0036	
	02S061	CONTROL LEVER (S/P 1)	100A0036	
	02S062	CONTROL LEVER (S/P 2)	100A0036	
	02S063	OIL PIPING (SUCTION)	100A0036	
	02S064	OIL PIPING (DELIVERY)	100A0036	
	02S065	OIL PIPING (RETURN)	100A0036	
	02S066	OIL PIPING (OIL COOLER)	100A0036	
	02S067	OIL PIPING (TRAVEL LH)	100A0036	
	02S068	OIL PIPING (TRAVEL RH)	100A0036	
	02S069-1	OIL PIPING (SWIVEL 1)	100A0036	
	02S069-2	OIL PIPING (SWIVEL 1)	100A0036	
	02S070	OIL PIPING (SWIVEL 2)	100A0036	
	02S071	OIL PIPING (SWING)	100A0036	
	02S072	OIL PIPING (LOCK)	100A0036	
	02S073-1	OIL PIPING (BOOM 1)	100A0036	
	02S073-2	OIL PIPING (BOOM 1)	100A0036	
	02S074	OIL PIPING (BOOM 2)	100A0036	
	02S075-1	OIL PIPING (ARM 1)	100A0036	
	02S075-2	OIL PIPING (ARM 1)	100A0036	
	02S076	OIL PIPING (ARM 2)	100A0036	
	02S077-1	OIL PIPING (BUCKET 1)	100A0036	
	02S077-2	OIL PIPING (BUCKET 1)	100A0036	
	02S078	OIL PIPING (BUCKET 2)	100A0036	
	02S079	OIL PIPING (BLADE)	100A0036	
	02S080	OIL PIPING (CLAMP)	100A0036	
	02S081	OIL PIPING (S/P)	100A0036	
	02S082	BOOM CYLINDER AND COMPONENT PARTS	100A0036	
	02S083	ARM CYLINDER AND COMPONENT PARTS	100A0036	
	02S084	BUCKET CYLINDER AND COMPONENT PARTS	100A0036	
	02S085	BLADE CYLINDER AND COMPONENT PARTS	100A0036	
	02S086	SWING CYLINDER AND COMPONENT PARTS	100A0036	
	FRONT ATTACHMENTS	02S087	SWING BRACKET	100A0036
		02S088	BOOM	100A0036
		02S089	CYLINDER COVER (BOOM)	100A0036
		02S090	ARM	100A0036
02S091		BUCKET LINK	100A0036	
02S092		BUCKET	100A0036	
02S093		BLADE	100A0036	
TRACK FRAME		02S094	TRACK FRAME	100A0036
		02S095	IDLER	100A0036
		02S096	TRACK ROLLER	100A0036
SWIVEL FRAME	02S097	CRAWLER	100A0036	
	02S098	SWIVEL FRAME	100A0036	
	02S099	SWIVEL GEAR CASE	100A0036	
	02S100	SWIVEL GEAR	100A0036	
	02S101	SWIVEL BEARING	100A0036	
	02S102	SEAT SUPPORT	100A0036	
	02S103	STEP	100A0036	

Item	Part No.	Description	Book
SWIVEL FRAME	02S104	COVER (LEFT)	100A0036
	02S105	COVER (TANK)	100A0036
	02S106	BONNET	100A0036
	02S107	SPONGE (1)	100A0036
	02S108	SPONGE (2)	100A0036
OPERATOR'S PLATFORM	02S109	WEIGHT	100A0036
	02S110	CANOPY	100A0036
	02S111	CABIN (BODY)	100A0036
	02S112	CABIN (DOOR)	100A0036
	02S113	CABIN (WINDOW 1)	100A0036
	02S114	CABIN (WINDOW 2)	100A0036
	02S115	CABIN (SPONGE)	100A0036
	02S116	CABIN (PARTITION PLATE)	100A0036
	02S117	INSTRUMENT PANEL	100A0036
	02S118	SEAT	100A0036
	02S119	CABIN (ELECTRICAL WIRING)	100A0036
	02S120	CABIN (WIPER MOTOR)	100A0036
	02S121	CABIN (HEATER)	100A0036
	02S122	CABIN (DEFROSTER)	100A0036
ACCESSORIES	02S123	LIGHT	100A0036
	02S124	LABEL	100A0036
	02S125	ACCESSORIES	100A0036
	02S126	WEIGHT KIT [OPTION]	100A0036
	02S127	LABEL KIT [OPTION]	100A0036

CRANKCASE

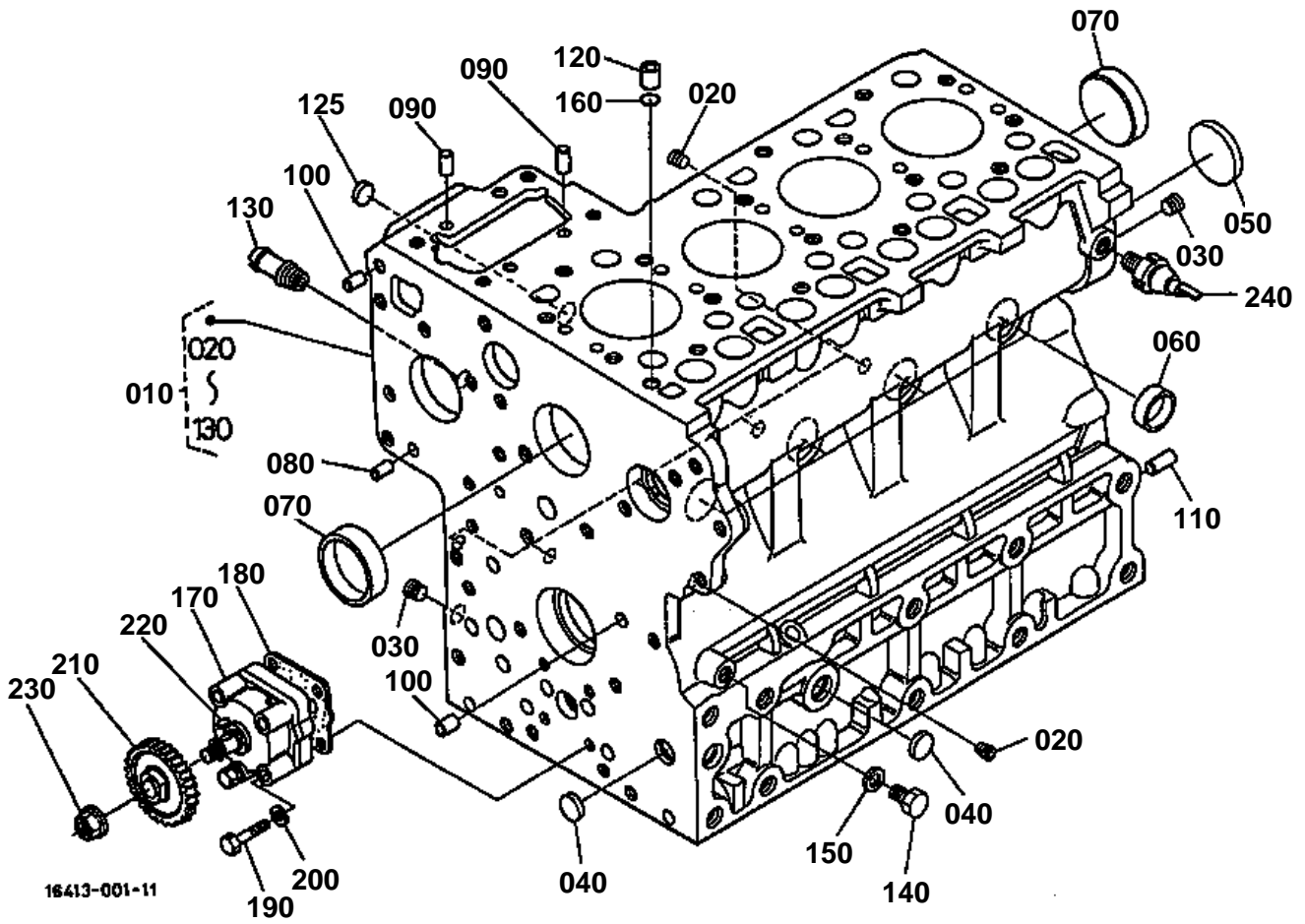



## CRANKCASE

↔ Interchangeable; ≠ not interchangeable; ← new for old; → old for new

REF.No	Part No.	Description	Q'ty	S.No.	I/C	REMARKS	Weight (kgf)	Weight (lb)
010	16413-01010	COMP.CRANKCASE	1				0	0
010	16413-01016	COMP.CRANKCASE	1		←		54.5	119.9
020	15521-96020	PLUG	6				0.003	0.0066
030	15521-96030	PLUG	2				0.007	0.0154
040	17391-96160	PLUG EXPANSION	3				0.003	0.0066
050	06311-75045	PLUG EXPANSION	1				0.026	0.0572
060	15221-03380	CAP SEALING	6				0.017	0.0374
070	15221-03390	CAP SEALING	2				0.03	0.066
080	05012-00408	PIN STRAIGHT	2				0.001	0.0022
090	05012-00609	PIN STRAIGHT	2				0.003	0.0066
100	05012-00612	PIN STRAIGHT	2				0.003	0.0066
110	05012-01018	PIN STRAIGHT	1				0.012	0.0264
120	15221-33650	PIN PIPE	1				0.004	0.0088
125	06311-85020	CAP SEALING	1				0.002	0.0044
130	15321-73340	PIPE WATER RETURN	1				0.016	0.0352
140	15221-33610	PLUG	1				0.009	0.0198
150	15021-33660	GASKET	1				0.001	0.0022
160	15221-33700	O RING	1				0.001	0.0022
170	15471-35010	ASSY PUMP OIL	1	<=6954			0	0
170	15471-35012	ASSY PUMP OIL	1	>=6955	↔		0.55	1.21
180	1A021-35150	GASKET OIL PUMP	1				0.001	0.0022
190	01053-50650	BOLT	4				0.011	0.0242
200	04512-60060	WASHER SPRING	4				0.001	0.0022
210	19202-35660	GEAR OIL PUMP DRIVE	1				0.23	0.506
220	05712-00410	KEY FEATHER	1				0.001	0.0022
230	15221-35682	NUT FLANGE	1				0.014	0.0308
240	15531-39010	SWITCH OIL	1				0.032	0.0704

# OIL PAN

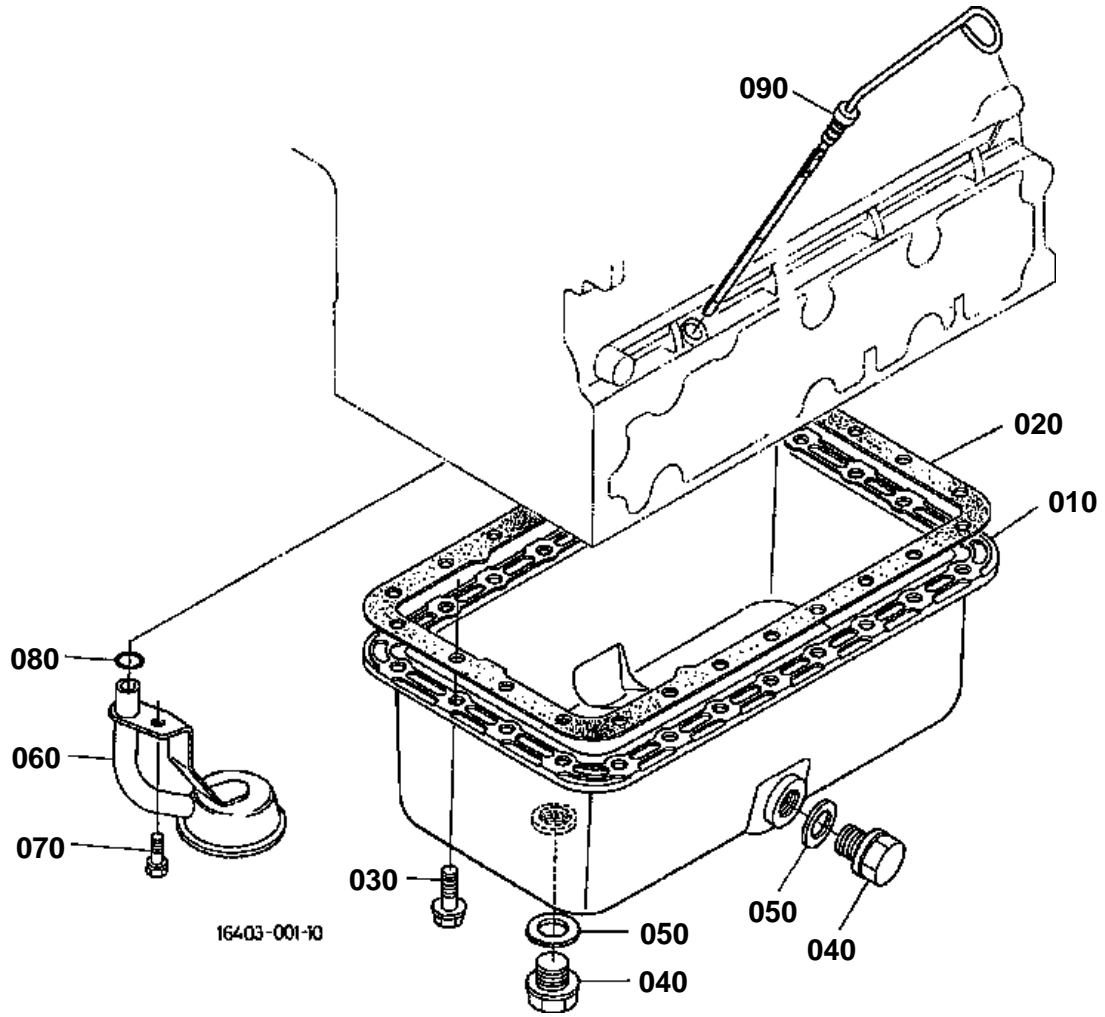





## OIL PAN

↔ Interchangeable; ≠ not interchangeable; ← new for old; → old for new

REF.No	Part No.	Description	Q'ty	S.No.	I/C	REMARKS	Weight (kgf)	Weight (lb)
010	19077-01500	COMP.OIL PAN	1				2.65	5.83
020	19228-01620	GASKET OIL PAN	1				0.07	0.154
030	17333-91010	BOLT FLANGE	24				0.03	0.066
040	16541-33750	PLUG DRAIN	2				0	0
050	15451-96670	GASKET	2				0.003	0.0066
060	16413-32110	FILTER OIL	1				0.24	0.528
070	01123-60816	BOLT	1				0.01	0.022
080	04814-00160	O RING	1				0.001	0.0022
090	16413-36412	GAUGE OIL	1				0.04	0.088

PISTON AND CRANKSHAFT

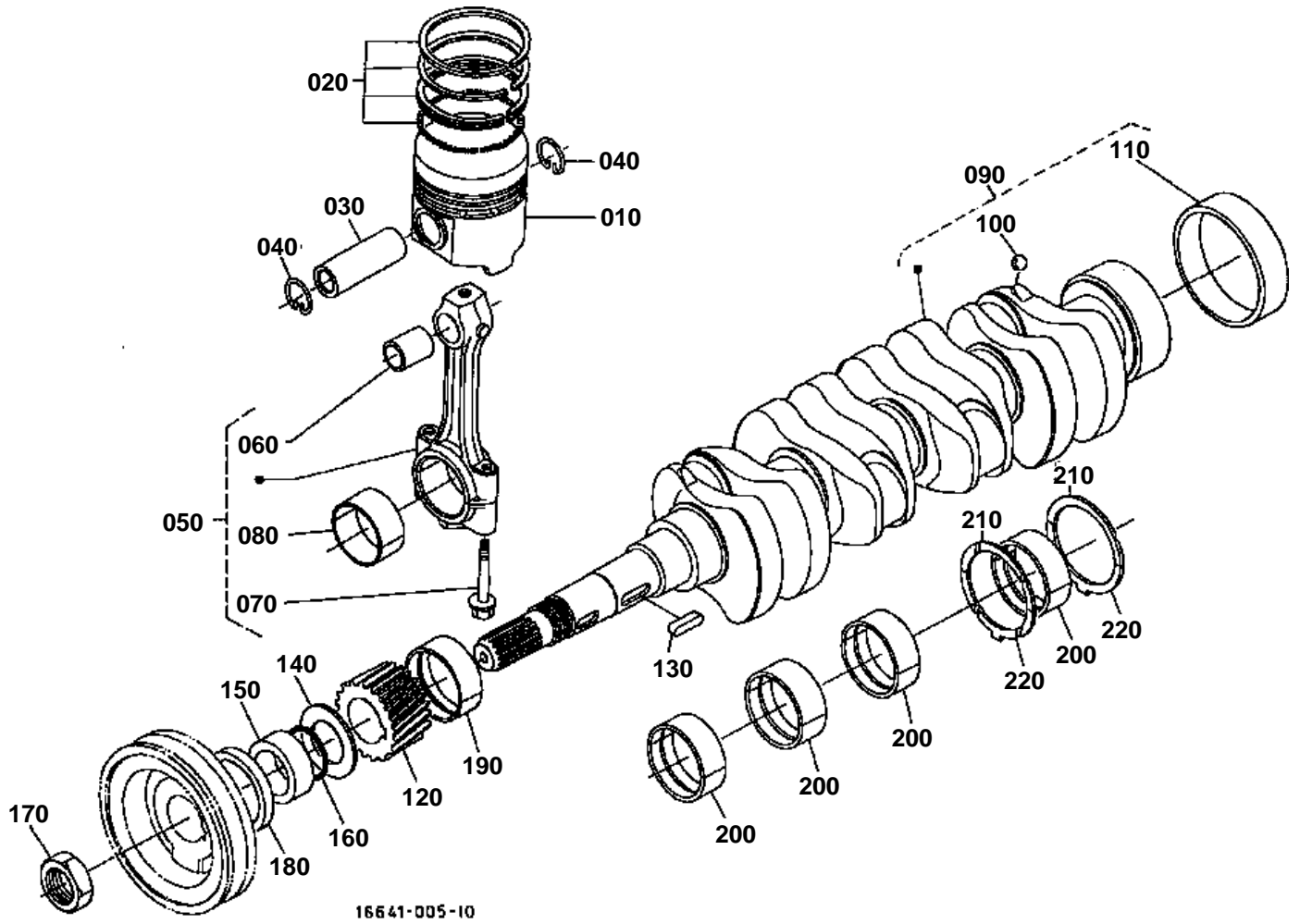



## PISTON AND CRANKSHAFT

↔ Interchangeable; ≠ not interchangeable; ← new for old; → old for new

REF.No	Part No.	Description	Q'ty	S.No.	I/C	REMARKS	Weight (kgf)	Weight (lb)
010	16423-21110	PISTON	4			STD	0.58	1.276
010	16423-21910	PISTON	4			+0.5MM	0.5	1.1
020	17331-21050	ASSY PISTON RING	4			STD	0.065	0.143
020	17331-21090	ASSY PISTON RING	4			+0.5MM	0.065	0.143
030	14901-21310	PIN PISTON	4				0.17	0.374
040	14109-21330	CIR CLIP INTERNAL	8				0.001	0.0022
050	17311-22010	ASSY CONNECTING ROD	4				0.885	1.947
060	17331-21980	BUSH PISTON PIN	4				0.025	0.055
070	15521-22142	BOLT CONNECTING ROD	8				0.026	0.0572
080	17311-22310	METAL CRANKPIN	4			STD SET	0.045	0.099
080	17331-22970	METAL CRANKPIN	4			-0.2MM SET	0.05	0.11
080	17331-22980	METAL CRANKPIN	4			-0.4MM SET	0.045	0.099
090	16641-23010	COMP.CRANKSHAFT	1				17	37.4
100	07715-00401	BALL	4				0.001	0.0022
110	19202-23280	BUSH CRANKSHAFT	1				0.09	0.198
120	15469-24112	GEAR CRANK	1				0.1	0.22
130	05712-00720	KEY FEATHER	1				0.008	0.0176
140	15471-23312	SLINGER OIL	1				0.008	0.0176
150	19202-23250	COLLAR CRANKSHAFT	1				0.065	0.143
160	19202-96760	O RING	1				0.001	0.0022
170	15221-23360	NUT CRANKSHAFT	1				0.11	0.242
180	19202-04140	SEAL OIL	1				0.015	0.033
190	17311-23472	METAL CRANKSHAFT	1			STD	0.06	0.132
190	17311-23910	METAL CRANKSHAFT	1			-0.2MM	0.05	0.11
190	17311-23920	METAL CRANKSHAFT	1			-0.4MM	0.06	0.132
200	17311-23480	METAL CRANKSHAFT	4			STD SET	0.045	0.099
200	17311-23930	METAL CRANKSHAFT	4			-0.2MM SET	0.05	0.11
200	17311-23940	METAL CRANKSHAFT	4			-0.4MM SET	0.06	0.132
210	15521-23530	METAL SIDE	2			STD	0.01	0.022
210	15521-23950	METAL SIDE	1			+0.2MM	0.01	0.022
210	15521-23960	METAL SIDE	1			+0.4MM	0.01	0.022
220	19202-23540	METAL SIDE	2			STD	0.01	0.022
220	19202-23970	METAL SIDE	2			+0.2MM	0.01	0.022
220	19202-23980	METAL SIDE	2			+0.4MM	0.01	0.022

MAIN BEARING CASE

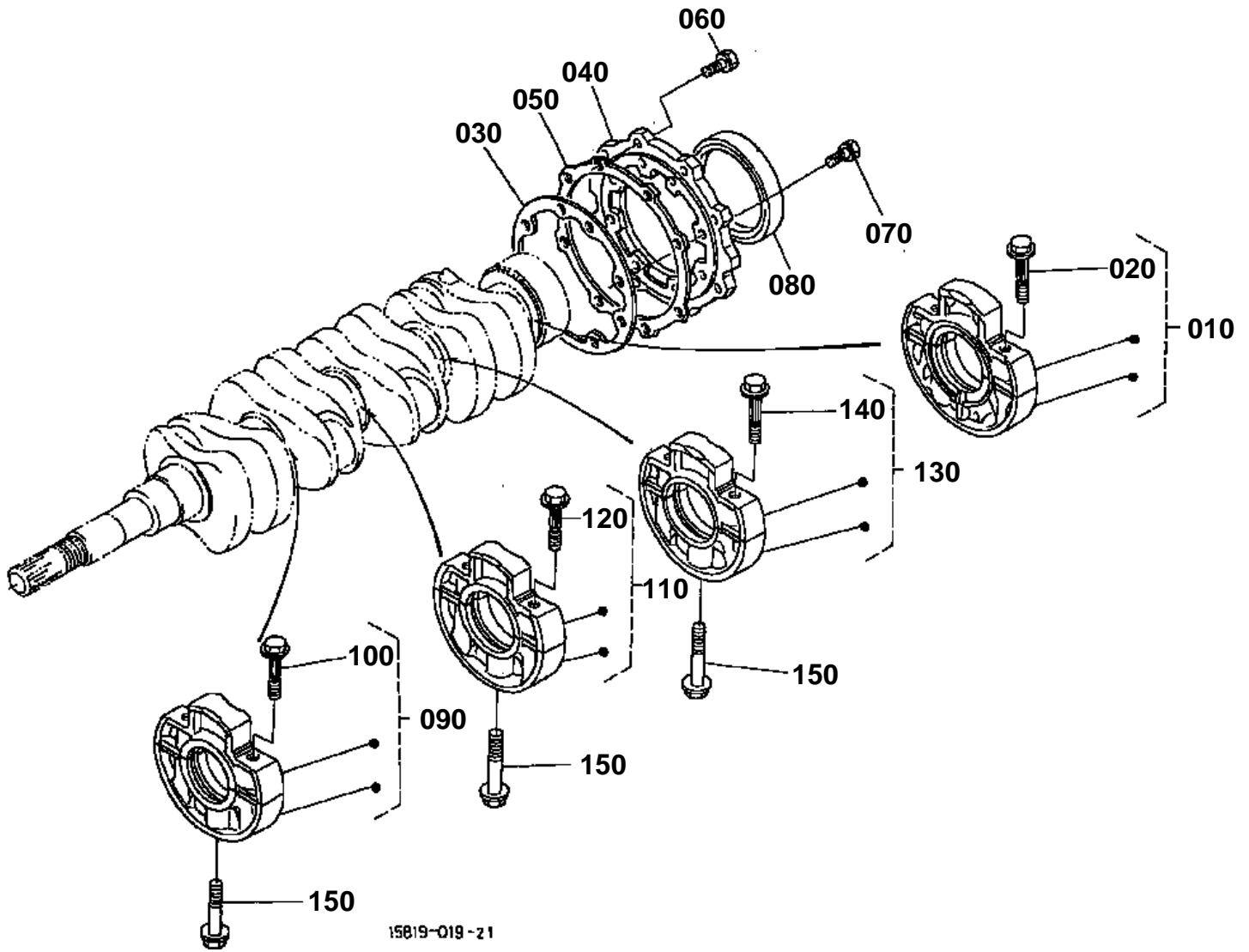



## MAIN BEARING CASE

↔ Interchangeable; ≠ not interchangeable; ← new for old; → old for new

REF.No	Part No.	Description	Q'ty	S.No.	I/C	REMARKS	Weight (kgf)	Weight (lb)
010	19013-07090	ASSY BRG.CASE WHEEL	1				1.55	3.41
010	19013-07090	ASSY BRG.CASE WHEEL	1		↔		1.55	3.41
020	19013-04540	BOLT BEARING CASE	2				0.038	0.0836
030	19077-04360	GASKET BEARING CASE	1				0.004	0.0088
040	19013-04813	COVER BEARING CASE	1				0.41	0.902
050	1A091-04820	GASKET BRG.CASE COV.	1				0.006	0.0132
060	01123-50825	BOLT	8				0.013	0.0286
070	01123-50828	BOLT	8				0.014	0.0308
080	19202-04460	SEAL OIL	1				0.055	0.121
090	19013-07040	ASSY BRG.CASE MAIN	1				1.5	3.3
090	19013-07040	ASSY BRG.CASE MAIN	1		↔		1.5	3.3
100	19013-04540	BOLT BEARING CASE	2				0.038	0.0836
110	19013-07050	ASSY BRG.CASE MAIN	1				1.495	3.289
110	19013-07050	ASSY BRG.CASE MAIN	1		↔		1.495	3.289
120	19013-04540	BOLT BEARING CASE	2				0.038	0.0836
130	19013-07060	ASSY BRG.CASE MAIN	1				1.52	3.344
130	19013-07060	ASSY BRG.CASE MAIN	1		↔		1.52	3.344
140	19013-04540	BOLT BEARING CASE	2				0.038	0.0836
150	15601-04560	BOLT BEARING CASE	3				0.06	0.132

# CAMSHAFT

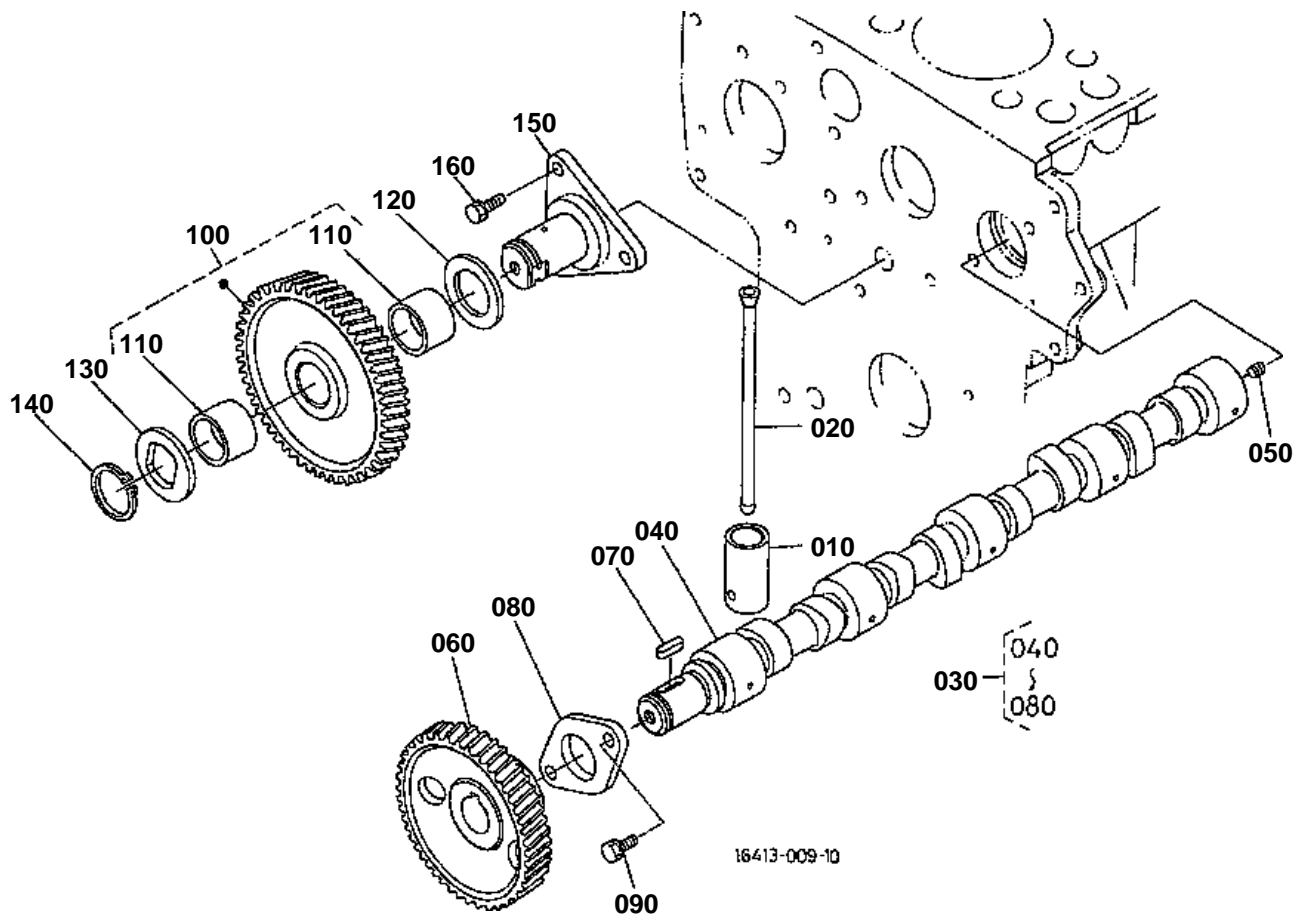



## CAMSHAFT

↔ Interchangeable; ≠ not interchangeable; ← new for old; → old for new

REF.No	Part No.	Description	Q'ty	S.No.	I/C	REMARKS	Weight (kgf)	Weight (lb)
010	15601-15550	TAPPET	8				0.08	0.176
020	19013-15110	PUSH ROD	8				0.05	0.11
030	16413-16010	ASSY CAMSHAFT	1				4.2	9.24
040	17343-16150	CAMSHAFT	1				2.2	4.84
050	15521-93610	SCREW SET	1				0.002	0.0044
060	15221-16510	GEAR CAMSHAFT	1				0.85	1.87
070	05712-00720	KEY FEATHER	1				0.008	0.0176
080	15221-16270	STOPPER CAMSHAFT	1				0.073	0.1606
090	01123-50818	BOLT	2				0.012	0.0264
100	15601-24010	COMP.GEAR IDLE	1				1.07	2.354
110	15221-24980	BUSH IDLE GEAR	2				0.02	0.044
120	15521-24360	COLLAR	1				0.015	0.033
130	15521-24370	COLLAR	1				0.015	0.033
140	15221-24320	CIR CLIP IDLE GEAR	1				0.01	0.022
150	15221-24250	SHAFT IDLE GEAR	1				0.48	1.056
160	01123-50818	BOLT	3				0.012	0.0264

CYLINDER HEAD

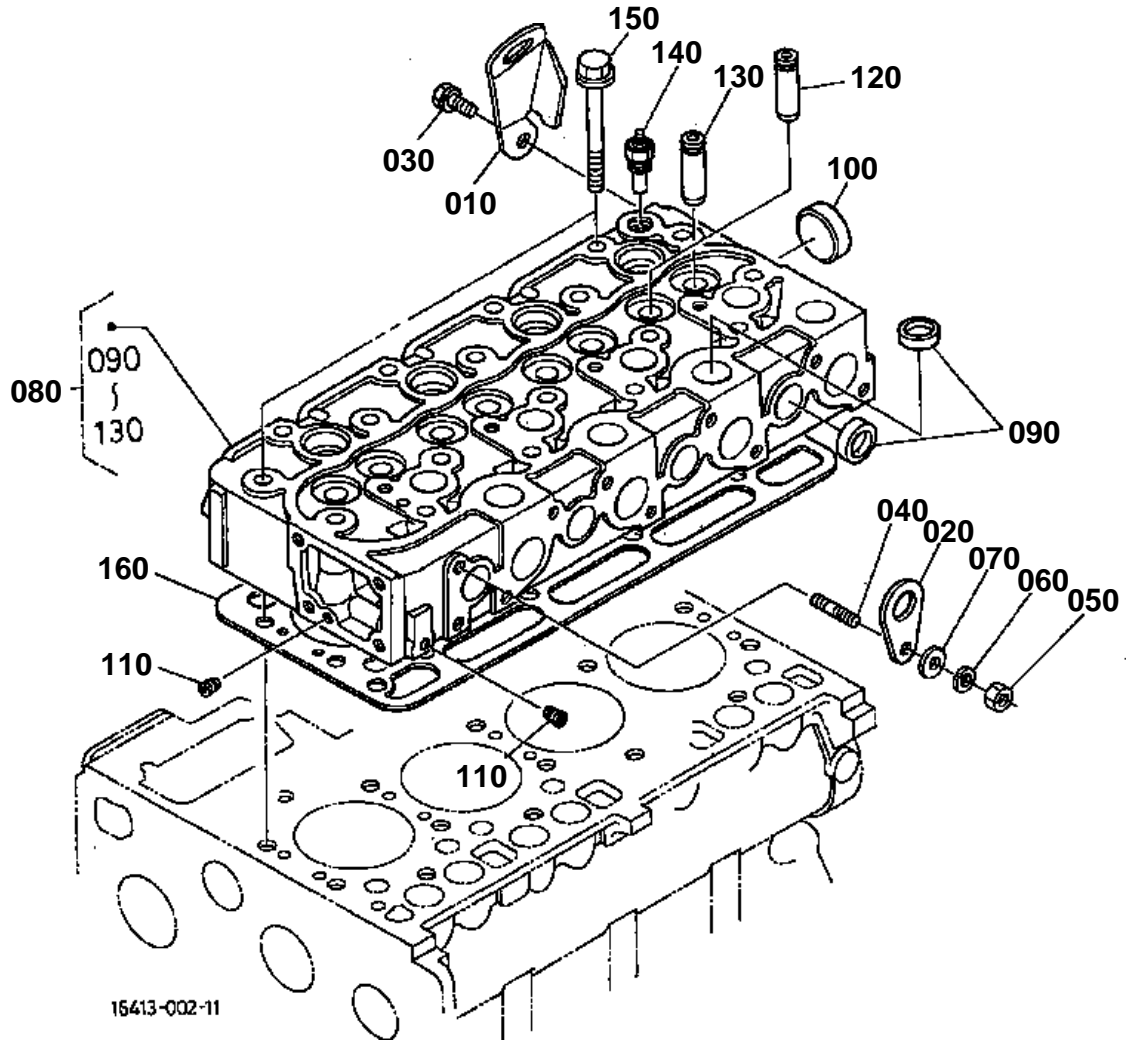





## CYLINDER HEAD

↔ Interchangeable; ≠ not interchangeable; ← new for old; → old for new

REF.No	Part No.	Description	Q'ty	S.No.	I/C	REMARKS	Weight (kgf)	Weight (lb)
010	16415-01752	HOOK ENGINE	1				0.115	0.253
020	15221-01750	HOOK ENGINE	1				0.04	0.088
030	01123-60816	BOLT	1				0.01	0.022
040	15221-91530	STUD	1				0.011	0.0242
050	02156-50080	NUT	1				0.004	0.0088
060	04512-60080	WASHER SPRING	1				0.002	0.0044
070	04012-50080	WASHER PLAIN	1				0.001	0.0022
080	16429-03040	COMP.CYLINDER HEAD	1				19.1	42.02
090	15221-03370	CAP SEALING	12				0.01	0.022
100	15221-03490	CAP SEALING	1				0.02	0.044
110	15261-96010	PLUG	2				0.002	0.0044
120	17321-13580	GUIDE INLET VALVE	4				0.015	0.033
130	17321-13560	GUIDE EXHAUST VALVE	4				0.02	0.044
140	31351-32830	SENSOR THERMO	1				0.02	0.044
150	19013-03450	BOLT CYLINDER HEAD	18				0.077	0.1694
160	19077-03310	GASKET CYLINDER HEAD	1				0.13	0.286

# VALVE AND ROCKER ARM

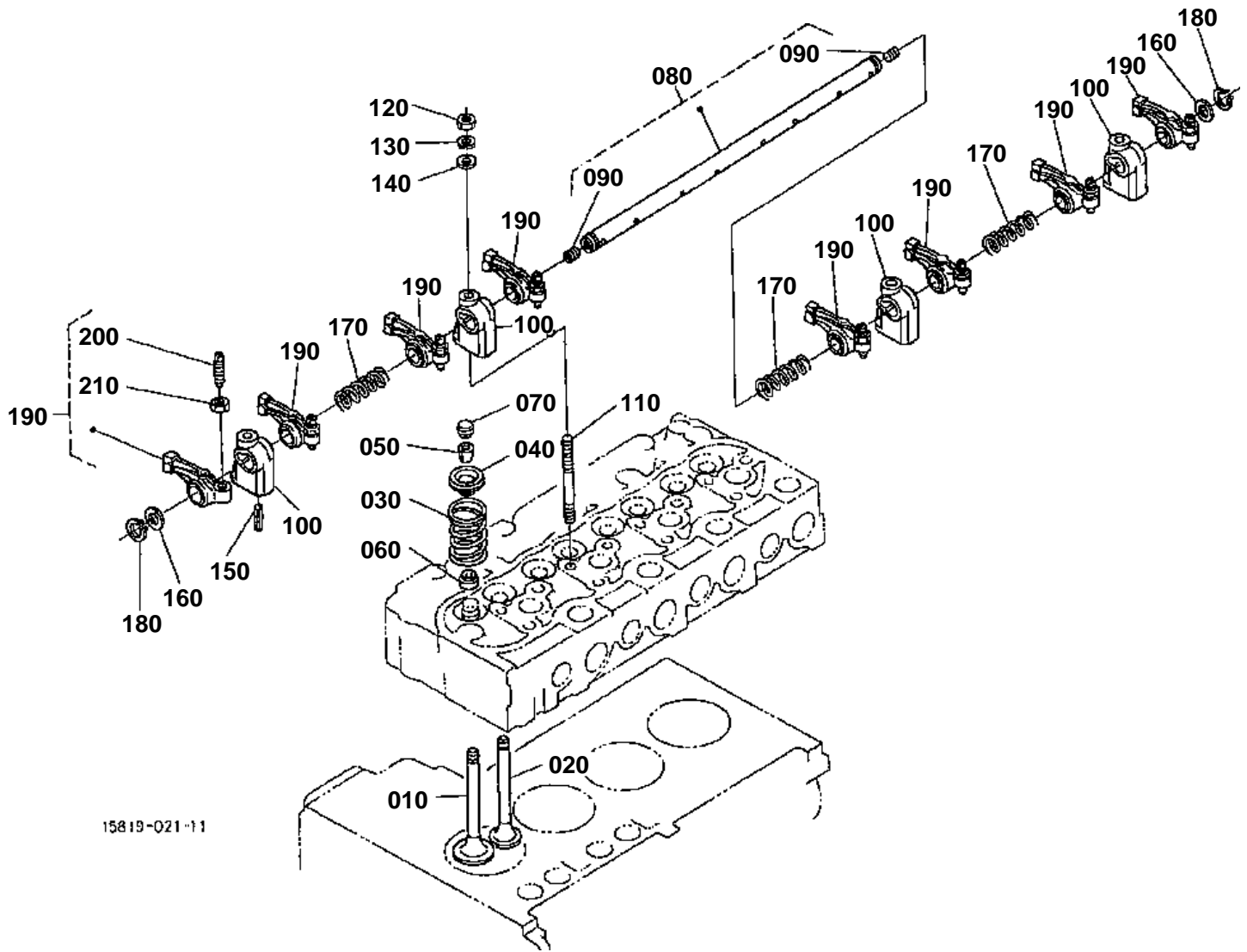

15819-021-11



## VALVE AND ROCKER ARM

↔ Interchangeable; ≠ not interchangeable; ← new for old; → old for new

REF.No	Part No.	Description	Q'ty	S.No.	I/C	REMARKS	Weight (kgf)	Weight (lb)
010	16484-13110	VALVE INLET	4				0.06	0.132
020	16484-13120	VALVE EXHAUST	4				0.13	0.286
030	15221-13240	SPRING VALVE	8				0.036	0.0792
040	15221-13330	RETAINER VALVE SP.	8				0.03	0.066
050	15221-13980	COLLET VALVE SPRING	8			SET	0.002	0.0044
060	15221-13150	SEAL VALVE STEM	8				0.001	0.0022
070	15221-13280	CAP VALVE	8				0.006	0.0132
080	15401-14052	ASSY SHAFT R-ARM	1				0.32	0.704
090	03410-50808	SCREW SET	2				0.002	0.0044
100	15221-14350	BRACKET ROCKER ARM	4				0.044	0.0968
110	15521-91500	STUD	4				0.035	0.077
120	02156-50080	NUT	4				0.004	0.0088
130	04512-60080	WASHER SPRING	4				0.002	0.0044
140	04012-50080	WASHER PLAIN	4				0.001	0.0022
150	05411-00528	PIN SPRING	1				0.003	0.0066
160	15221-14430	WASHER R-ARM.SHAFT	2				0.002	0.0044
170	15221-14310	SPRING ROCKER ARM	3				0.005	0.011
180	04612-00140	CIR CLIP EXTERNAL	2				0.001	0.0022
190	15621-14030	ASSY ROCKER ARM	8				0.1	0.22
200	15521-14230	SCREW ADJUSTING	8				0.009	0.0198
210	15021-14240	NUT	8				0.003	0.0066

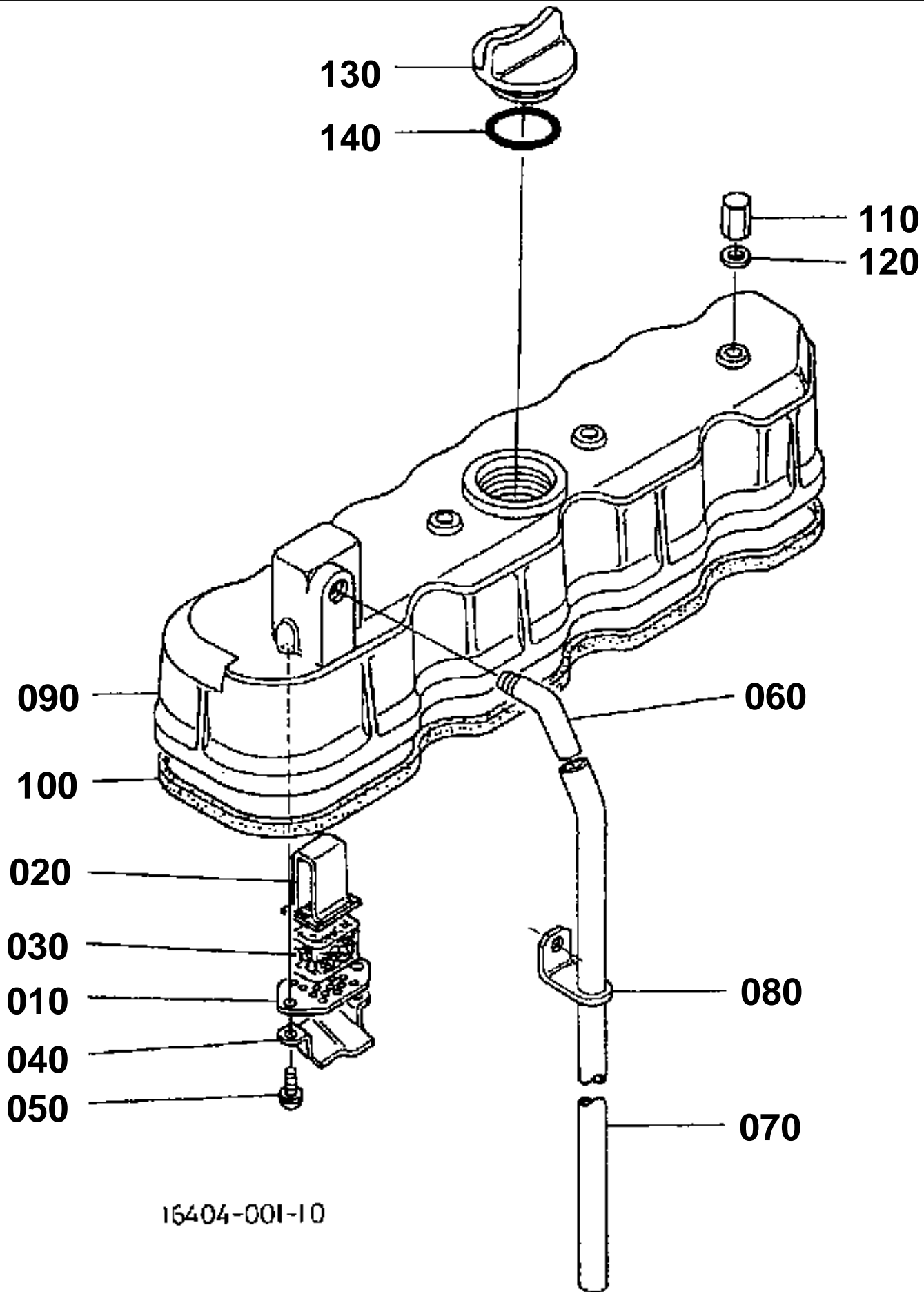

16404-001-10