

Instructions for Parts Books

The heading at the top of the page will be the same for the picture of the parts at it is for the page with the part numbers.

Definition of column headings on part number pages:

REF.No → The number referring to the part on the picture page of the parts book.

Part No. → The number assigned to this part at the time of printing the parts book.

Description → Discription of part.

Q'ty → Quantity of part used on that page.

S.No. → Serial number range of the equipment that this part will fit.

>= Your serial number should be greater than or equal to the number shown.

<= Your serial number should be lesser than or equal to the serial number shown.

I/C → Interchangeability of part shown.

↔ The part shown will work for the older and later serial number.

The part shown is not interchangeable with the other serial number.

← new for old

→ old for new

Remarks → Notes about this particulart part. Sometimes this may say except [FR] or [CA]

Note about Country Codes:

The parts books we use in the United States of America may also contain information about a part that would be different in another country. It is important that you are aware of the country codes in some instances.

Symbol	Country
A	United States of America
CA	Canada
FR	France
GR	Greece
PO	Portugal
AU	Australia

If the remarks column says for example EXCEPT [FR] this part works in all countries except France. That means it will work here in the USA.

ALL PRODUCT INDEX
KX101

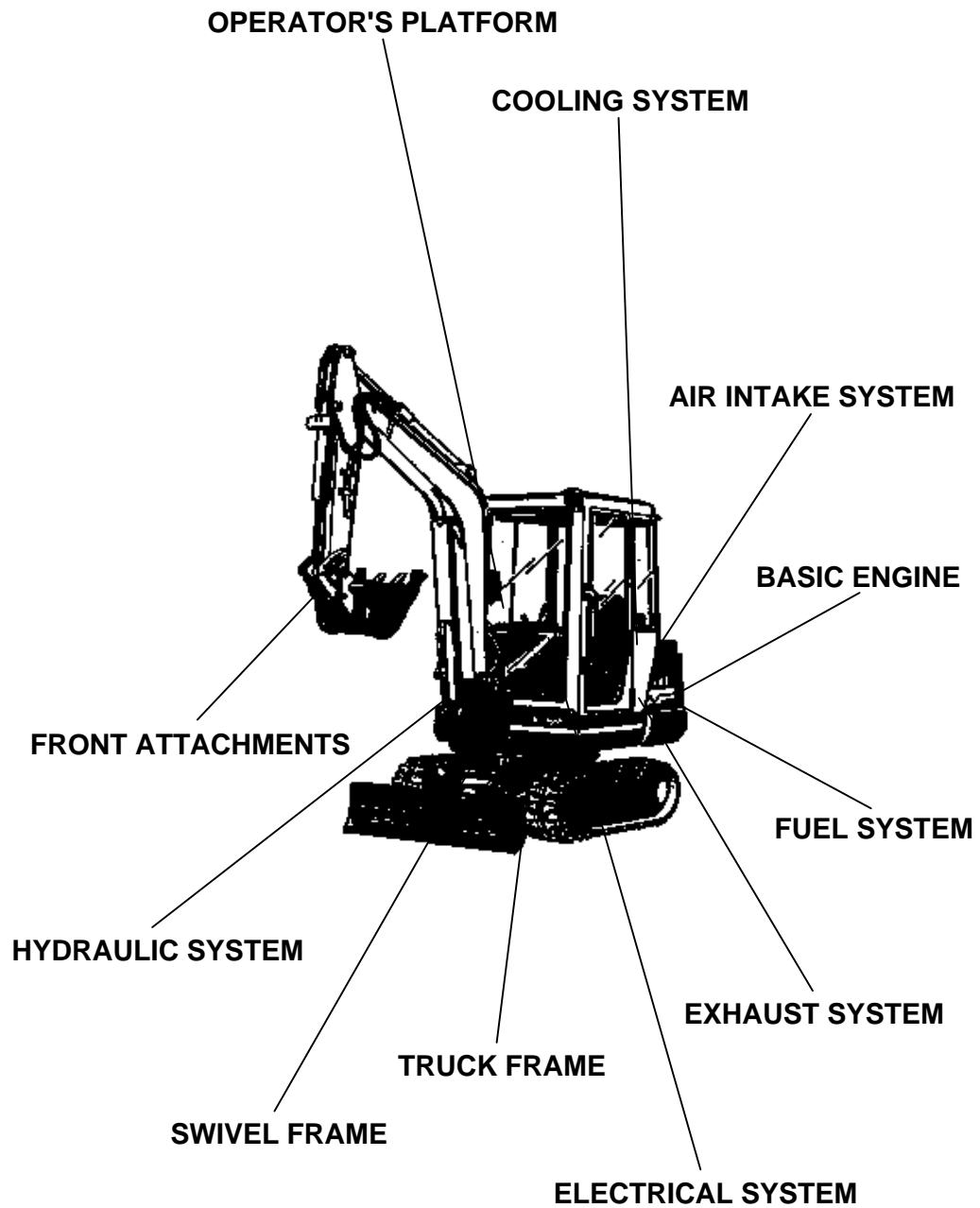

ACCESSORIES

Item	Part No.	Description	Book
BASIC ENGINE	01S001	CRANKCASE	100K0156
	01S002	OIL PAN	100K0156
	01S003	PISTON, CRANKSHAFT	100K0156
	01S004	MAIN BEARING CASE	100K0156
	01S005	CAMSHAFT	100K0156
	01S006	CYLINDER HEAD	100K0156
	01S007	VALVE, ROCKER ARM	100K0156
	01S008	CYLINDER HEAD COVER	100K0156
	01S009	GEAR CASE	100K0156
	01S010	ENGINE STOP LEVER	100K0156
FUEL SYSTEM	01S014	NOZZLE HOLDER, GLOW PLUG	100K0156
	01S015	NOZZLE HOLDER (COMPONENT PARTS)	100K0156
	01S016	SPEED CONTROL PLATE	100K0156
	01S017	GOVERNOR	100K0156
	01S018	INJECTION PUMP, CAMSHAFT (1)	100K0156
	01S019	INJECTION PUMP (COMPONENT PARTS)	100K0156
	01S020	INJECTION PUMP, CAMSHAFT (2)	100K0156
	01S024	WATER FLANGE	100K0156
COOLING SYSTEM	01S025	WATER PUMP	100K0156
	01S028	FLYWHEEL, STARTER	100K0156
ELECTRICAL SYSTEM	01S02901	STARTER (COMPONENT PARTS)	100K0156
	01S02902	STARTER (COMPONENT PARTS)	100K0156
	01S030	DYNAMO	100K0156
	01S031	DYNAMO (COMPONENT PARTS)	100K0156
	01S011	ENGINE BRACKET	100K0156
BASIC ENGINE	01S01201	AIR CLEANER, INLET MANIFOLD	100K0156
AIR INTAKE SYSTEM	01S013	MUFFLER, EXHAUST MANIFOLD	100K0156
EXHAUST SYSTEM	01S021	ACCEL LEVER	100K0156
FUEL SYSTEM	01S022	FUEL PIPING	100K0156
	01S023	FUEL TANK	100K0156
	01S026	RADIATOR	100K0156
COOLING SYSTEM	01S027	WATER PIPE	100K0156
	01S032	BATTERY	100K0156
ELECTRICAL SYSTEM	01S033	REGULATOR, HORN	100K0156
	01S034	SWITCH, METER	100K0156
	01S035	ELECTRICAL WIRING	100K0156
	01S089	PUMP HOUSING	100K0156
	01S090	GEAR PUMP & COMPONENT PARTS	100K0156
HYDRAULIC SYSTEM	01S091	HYDRAULIC PUMP & COMPONENT PARTS	100K0156
	01S09201	DRIVE MOTOR & COMPONENT PARTS 1	100K0156
	01S09202	DRIVE MOTOR & COMPONENT PARTS 2	100K0156
	01S093	SWIVEL MOTOR & COMPONENT PARTS	100K0156
	01S094	ROTARY JOINT	100K0156
	01S095	OIL TANK	100K0156
	01S096	CONTROL VALVE (1)	100K0156
	01S097	CONTROL VALVE (1) (COMPONENT PARTS)	100K0156
	01S09801	SPOOL SECTION (TRAVEL RH)	100K0156
	01S09802	SPOOL SECTION (BOOM)	100K0156
	01S09803	SPOOL SECTION (BUCKET)	100K0156
	01S09804	SPOOL SECTION	100K0156
	01S09805	SPOOL SECTION (TRAVEL SPEED 2ND)	100K0156
	01S09806	SPOOL SECTION (TRAVEL LH)	100K0156
	01S09807	SPOOL SECTION (BOOM)	100K0156
	01S09808	SPOOL SECTION (ARM)	100K0156
	01S09809	SPOOL SECTION (S/P)	100K0156
	01S09810	SPACER SECTION	100K0156

Item	Part No.	Description	Book	
HYDRAULIC SYSTEM	01S099	CONTROL VALVE (3)	100K0156	
	01S100	CONTROL VALVE (3) (COMPONENT PARTS)	100K0156	
	01S10101	SPOOL SECTION (SWIVEL)	100K0156	
	01S10102	SPOOL SECTION (SWING)	100K0156	
	01S10103	SPOOL SECTION (BLADE)	100K0156	
	01S102	CHANGE VALVE	100K0156	
	01S103	CONTROL LEVER (FRAME)	100K0156	
	01S104	CONTROL LEVER (PATTERN SELECTOR)	100K0156	
	01S105	CONTROL LEVER (BOX LH)	100K0156	
	01S10601	CONTROL LEVER (LEVER LH)	100K0156	
	01S10602	PILOT VALVE (COMPONENT PARTS)	100K0156	
	01S107	CONTROL LEVER (BOX RH)	100K0156	
	01S108	CONTROL LEVER (LEVER RH)	100K0156	
	01S109	CONTROL LEVER (TRAVEL LH)	100K0156	
	01S110	CONTROL LEVER (TRAVEL RH)	100K0156	
	01S111	CONTROL TRAVEL PEDAL	100K0156	
	01S112	CONTROL LEVER (SAFETY LOCK LEVER)	100K0156	
	01S113	CONTROL PEDAL (SWIVEL/SWING CHANGE)	100K0156	
	01S114	CONTROL LEVER (BLADE)	100K0156	
	01S115	CONTROL LEVER (S/P)	100K0156	
	01S116	OIL PIPING (THIRD LINE)	100K0156	
	01S117	OIL PIPING (SUCTION)	100K0156	
	01S118	OIL PIPING (DELIVERY)	100K0156	
	01S119	OIL PIPING (UNLOAD VALVE) (COMPONENT PARTS)	100K0156	
	01S120	OIL PIPING (RETURN)	100K0156	
	01S121	OIL PIPING (OIL COOLER)	100K0156	
	01S122	OIL PIPING (TRAVEL LH)	100K0156	
	01S123	OIL PIPING (TRAVEL RH)	100K0156	
	01S124	OIL PIPING (SWIVEL / SWING)	100K0156	
	01S125	OIL PIPING (SWIVEL)	100K0156	
	01S126	OIL PIPING (SWING)	100K0156	
	01S127	OIL PIPING (LOCK)	100K0156	
	01S128	OIL PIPING (BOOM 1)	100K0156	
	01S129	OIL PIPING (BOOM 2)	100K0156	
	01S130	OIL PIPING (ARM 1)	100K0156	
	01S131	OIL PIPING (ARM 2)	100K0156	
	01S132	OIL PIPING (BUCKET 1)	100K0156	
	01S133	OIL PIPING (BUCKET 2)	100K0156	
	01S134	OIL PIPING (BLADE)	100K0156	
	01S135	OIL PIPING (CONFLUENCE)	100K0156	
	01S136	OIL PIPING (CUSHION)	100K0156	
	01S137	OIL PIPING (S/P)	100K0156	
	01S138	BOOM CYLINDER & COMPONENT PARTS	100K0156	
	01S139	ARM CYLINDER & COMPONENT PARTS	100K0156	
	01S140	BUCKET CYLINDER & COMPONENT PARTS	100K0156	
	01S141	BLADE CYLINDER & COMPONENT PARTS	100K0156	
	01S142	SWING CYLINDER & COMPONENT PARTS	100K0156	
	FRONT ATTACHMENTS	01S143	SWING BRACKET	100K0156
		01S144	BOOM	100K0156
01S145		CYLINDER COVER (BOOM)	100K0156	
01S146		ARM	100K0156	
01S147		BUCKET LINK	100K0156	
01S148		BUCKET	100K0156	
01S149		BLADE	100K0156	
TRUCK FRAME	01S150	TRUCK FRAME	100K0156	

Item	Part No.	Description	Book	
TRUCK FRAME	01S151	IDLER	100K0156	
	01S152	TRUCK ROLLER	100K0156	
	01S153	CRAWLER	100K0156	
SWIVEL FRAME	01S154	SWIVEL FRAME	100K0156	
	01S155	SWIVEL GEAR CASE	100K0156	
	01S156	SWIVEL GEAR	100K0156	
	01S157	SWIVEL BEARING	100K0156	
	01S158	FLOOR PLATE (1)	100K0156	
	01S159	FLOOR PLATE (2)	100K0156	
	01S160	BONNET	100K0156	
	01S16102	SPONGE (1) [KTC KCL KTA]	100K0156	
	01S162	SPONGE (2)	100K0156	
	01S16302	SPONGE (3) [KTC KCL KTA]	100K0156	
	01S164	WEIGHT	100K0156	
	OPERATOR'S PLATFORM	01S16502	CANOPY (ROPS) [KTC KCL KTA]	100K0156
		01S16602	CABIN (BODY) [KTC KCL KTA]	100K0156
01S16702		CABIN (DOOR) [KTC/KCL/KTA]	100K0156	
01S16802		CABIN (FRONT WINDOW) [KTC KCL KTA]	100K0156	
01S16902		CABIN (WINDOW) [KTC KCL KTA]	100K0156	
01S17002		CABIN (SPONGE) [KTC KCL KTA]	100K0156	
01S171		INSTRUMENT, PANEL	100K0156	
01S17203		SEAT [KTC KCL M.E. KTA]	100K0156	
01S173		CABIN (ELECTRICAL)	100K0156	
01S174		CABIN (WIPER MOTOR)	100K0156	
01S175		CABIN (DEFROSTER)	100K0156	
01S176		CABIN (HEATER)	100K0156	
01S177		LIGHT	100K0156	
ACCESSORIES		01S17802	LABEL [KTC KCL KTA]	100K0156
	01S179	ACCESSORIES	100K0156	

CRANKCASE

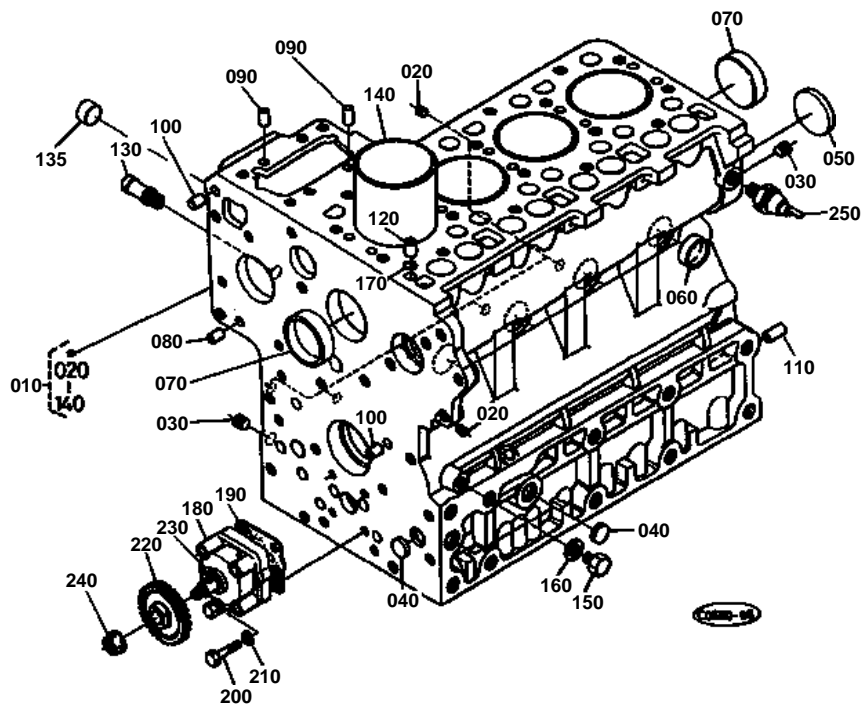



CRANKCASE

↔ Interchangeable; ≠ not interchangeable; ← new for old; → old for new

REF.No	Part No.	Description	Q'ty	S.No.	I/C	REMARKS	Weight (kgf)	Weight (lb)
010	16342-01010	COMP.CRANKCASE	1	<=15762			0	0
010	16342-01013	COMP.CRANKCASE	1	>=15763	←		61	134.2
020	15521-96020	PLUG	6				0.003	0.0066
030	15521-96030	PLUG	2				0.007	0.0154
040	06311-75018	PLUG	3	<=14673			0.004	0.0088
040	17391-96160	PLUG	3	>=14674	←		0.003	0.0066
050	06311-75045	PLUG	1				0.026	0.0572
060	15221-03380	CAP,SEALING	6				0.017	0.0374
070	15221-03390	CAP,SEALING	2				0.03	0.066
080	05012-00408	PIN,STRAIGHT	2				0.001	0.0022
090	05012-00609	PIN,STRAIGHT	2				0.003	0.0066
100	05012-00612	PIN,STRAIGHT	2				0.003	0.0066
110	05012-01018	PIN,STRAIGHT	1				0.012	0.0264
120	15221-33650	PIN,PIPE	1				0.004	0.0088
130	15321-73340	PIPE,WATER RETURN	1				0.016	0.0352
135	06311-85020	CAP,SEALING	1	>=15763			0.002	0.0044
140	15521-02310	LINER,CYLINDER	4				0.66	1.452
150	15221-33610	PLUG	1				0.009	0.0198
160	15021-33660	GASKET	1				0.001	0.0022
170	15221-33700	O RING	1				0.001	0.0022
180	15471-35010	ASSY PUMP,OIL	1				0	0
190	15221-35150	GASKET,OIL PUMP	1	<=18067			0	0
190	15296-35150	GASKET,OIL PUMP NA	1	>=18068	≠		0.001	0.0022
200	01053-50650	BOLT	4				0.011	0.0242
210	04512-50060	WASHER,SPRING	4				0	0
220	19202-35660	GEAR,OIL PUMP DRIVE	1				0.23	0.506
230	05712-00410	KEY,FEATHER	1				0.001	0.0022
240	15221-35682	NUT,FLANGE	1				0.014	0.0308
250	15531-39010	SWITCH,OIL	1				0.032	0.0704

OIL PAN

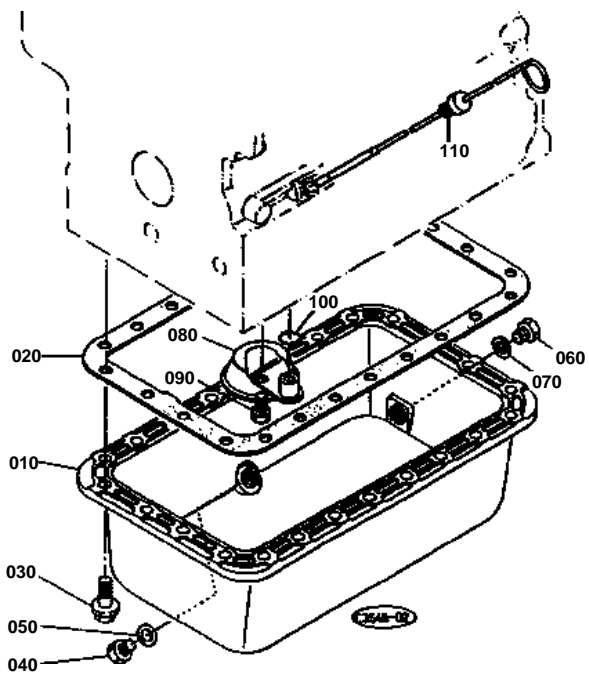



OIL PAN

↔ Interchangeable; ≠ not interchangeable; ← new for old; → old for new

REF.No	Part No.	Description	Q'ty	S.No.	I/C	REMARKS	Weight (kgf)	Weight (lb)
010	15434-01610	OIL PAN	1	<=17842			0	0
010	15434-01613	OIL PAN	1	>=17843	↔		2.25	4.95
020	15469-01620	GASKET,OIL PAN	1	<=18067			0	0
020	19228-01620	GASKET,OIL PAN NA	1	>=18068	≠		0.07	0.154
030	17333-91010	BOLT,FLANGE	24				0.03	0.066
040	15221-33750	PLUG	1				0.032	0.0704
050	15109-33660	GASKET	1				0.001	0.0022
060	06331-45016	PLUG	1				0.05	0.11
070	04724-00160	GASKET	1				0.003	0.0066
080	15628-32110	FILTER,OIL	1				0.225	0.495
090	01123-50816	BOLT	1				0.011	0.0242
100	04814-00160	O RING	1				0.001	0.0022
110	15435-36410	GAUGE,OIL	1	<=15156			0	0
110	15435-36412	GAUGE,OIL	1	>=15157	←		0	0
110	15435-36413	GAUGE,OIL	1	>=17238	←		0	0
110	15435-36414	GAUGE,OIL	1	>=18821	←		0.055	0.121

PISTON, CRANKSHAFT

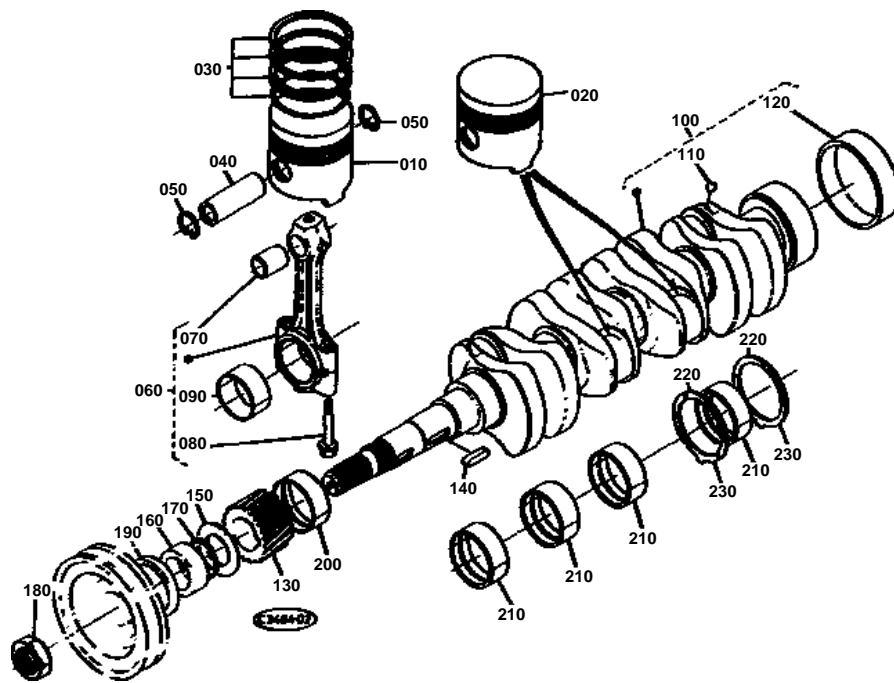



PISTON, CRANKSHAFT

↔ Interchangeable; ≠ not interchangeable; ← new for old; → old for new

REF.No	Part No.	Description	Q'ty	S.No.	I/C	REMARKS	Weight (kgf)	Weight (lb)
010	19274-21110	PISTON	2			STD	0.56	1.232
010	19274-21910	PISTON	2			+0,5MM	0.57	1.254
020	19439-21110	PISTON	2			STD	0.56	1.232
020	19439-21910	PISTON	2			+0,5MM	0.54	1.188
030	19274-21050	ASSY PISTON RING	4			STD	0.06	0.132
030	19274-21092	ASSY PISTON RING	4			+0,5MM	0.06	0.132
040	15521-21310	PIN,PISTON	4				0.156	0.3432
050	15221-21330	CIR CLIP,PISTON PIN	8				0.002	0.0044
060	15471-22012	ASSY CONNECTING ROD	4				0.76	1.672
070	15221-21982	BUSH,PISTON PIN	4				0.024	0.0528
080	15521-22142	BOLT,CONNECTING ROD	8				0.026	0.0572
090	15471-22310	METAL,CRANKPIN	4			SET STD	0.03	0.066
090	15471-22970	METAL,CRANKPIN	4			SET -0,2MM	0.04	0.088
090	15471-22980	METAL,CRANKPIN	4			SET -0,4MM	0.04	0.088
100	19202-23010	COMP.CRANKSHAFT	1				16.4	36.08
110	07715-00401	BALL	4				0.001	0.0022
120	19202-23280	SLEEVE,CRANKSHAFT	1				0.09	0.198
130	15469-24112	GEAR,CRANKSHAFT	1				0.1	0.22
140	05712-00720	KEY,FEATHER	1				0.008	0.0176
150	15471-23312	SLINGER,OIL	1				0.008	0.0176
160	19202-23250	COLLAR,CRANKSHAFT	1				0.065	0.143
170	19202-96760	O RING	1				0.001	0.0022
180	15221-23360	NUT,CRANKSHAFT	1				0.11	0.242
190	19202-04140	SEAL,OIL	1				0.015	0.033
200	17311-23470	METAL,CRANKSHAFT	1			SET STD	0	0
200	17331-23910	METAL,CRANKSHAFT	1			SET -0.2MM	0	0
200	17331-23920	METAL,CRANKSHAFT	1			SET -0.4MM	0	0
210	17311-23480	METAL,CRANKSHAFT	4			SET STD	0.045	0.099
210	17331-23930	METAL,CRANKSHAFT	4			SET -0.2MM	0	0
210	17331-23940	METAL,CRANKSHAFT	4			SET -0.4MM	0	0
220	15521-23530	METAL,SIDE	2			STD	0.01	0.022
220	15521-23950	METAL,SIDE	2			+0,2MM	0.01	0.022
220	15521-23960	METAL,SIDE	2			+0,4MM	0.01	0.022
230	19202-23540	METAL,SIDE	2			STD	0.01	0.022
230	19202-23970	METAL,SIDE	2			+0,2MM	0.01	0.022
230	19202-23980	METAL,SIDE	2			+0,4MM	0.01	0.022

MAIN BEARING CASE

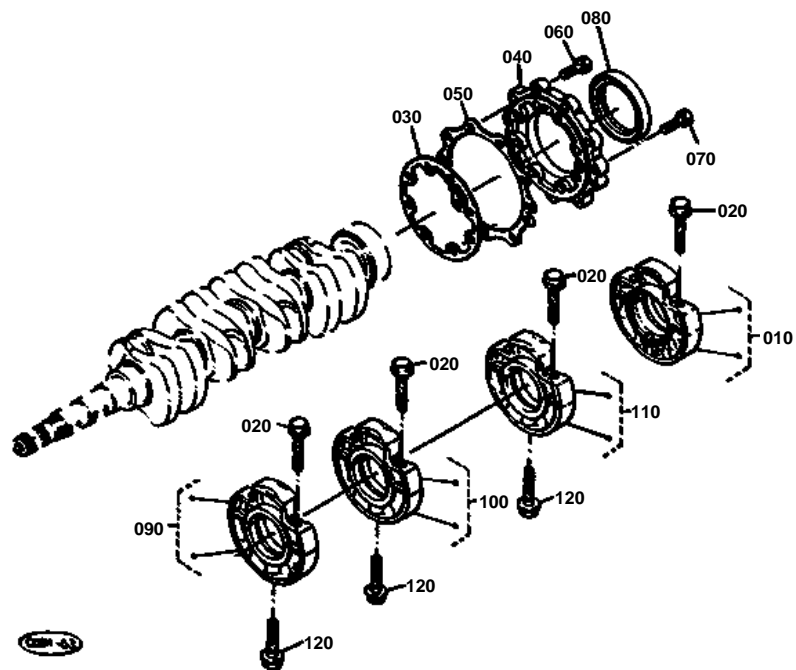



MAIN BEARING CASE

↔ Interchangeable; ≠ not interchangeable; ← new for old; → old for new

REF.No	Part No.	Description	Q'ty	S.No.	I/C	REMARKS	Weight (kgf)	Weight (lb)
010	19202-04040	ASSY CASE,MAIN BRG.	1				1.28	2.816
020	15601-04540	BOLT,BEARING CASE	8				0.034	0.0748
030	15221-04360	GASKET	1	<=15856			0	0
030	19207-04360	GASKET	1	>=15857	↔		0.005	0.011
040	19202-04810	COVER,BEARING CASE	1				0.36	0.792
050	15201-04820	GASKET,BRG.CASE COV.	1	<=18067			0	0
050	15313-04820	GASKET,BRG.CASE COV.	1	>=18068	≠		0.005	0.011
060	01123-50825	BOLT	8				0.013	0.0286
070	01123-50828	BOLT	8				0.014	0.0308
080	19202-04460	SEAL,OIL	1				0.055	0.121
090	15521-04055	ASSY CASE,MAIN BRG.	1				1.2	2.64
100	15521-04065	ASSY CASE,MAIN BRG.	1				1.225	2.695
110	15411-04070	ASSY CASE,MAIN BRG.	1				1.25	2.75
120	15601-04560	BOLT,BEARING CASE	3				0.06	0.132

CAMSHAFT

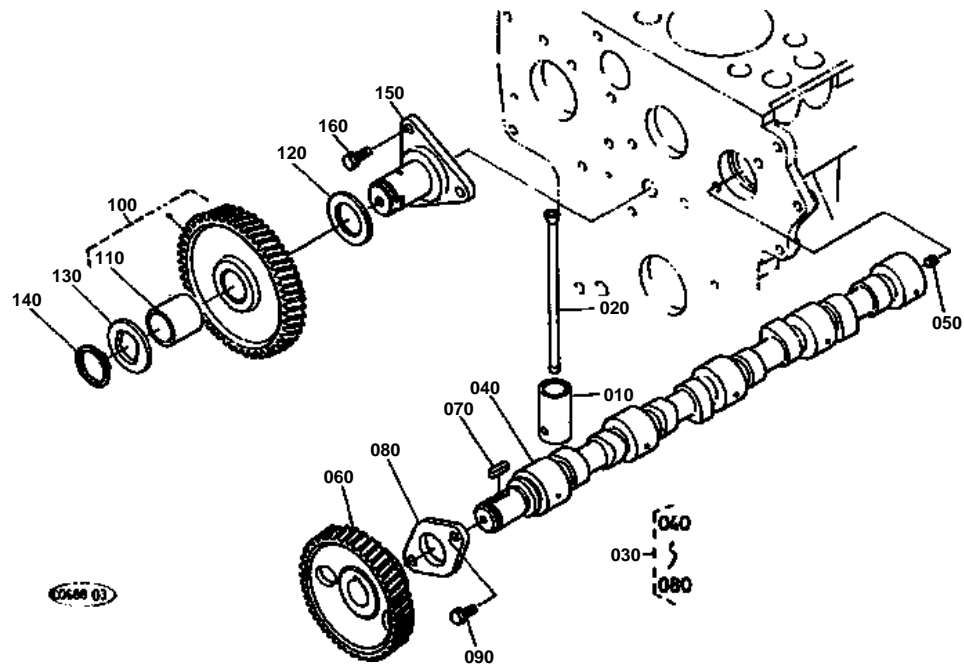



CAMSHAFT

↔ Interchangeable; ≠ not interchangeable; ← new for old; → old for new

REF.No	Part No.	Description	Q'ty	S.No.	I/C	REMARKS	Weight (kgf)	Weight (lb)
010	15221-15550	TAPPET	8	≤19726			0	0
010	15601-15550	TAPPET	8	≥19727	↔		0.08	0.176
020	15221-15110	PUSH ROD	8				0.05	0.11
030	15815-16010	ASSY CAMSHAFT	1	≤16028			3.8	8.36
030	15471-16010	ASSY CAMSHAFT	1	≥16029	≠		3.26	7.172
040	15471-16150	CAMSHAFT	1				2.4	5.28
050	15521-93610	SCREW,SET	1				0.002	0.0044
060	15221-16510	GEAR,CAMSHAFT	1	≤16028			0.85	1.87
060	15521-16510	GEAR,CAMSHAFT	1	≥16029	≠		0.85	1.87
070	05712-00720	KEY,FEATHER	1				0.008	0.0176
080	15221-16270	STOPPER,CAMSHAFT	1				0.073	0.1606
090	01123-50818	BOLT	2				0.012	0.0264
100	15601-24010	COMP.GEAR,IDLE	1	≤16028			1.07	2.354
100	16427-24010	COMP.GEAR,IDLE	1	≥16029	≠		1.2	2.64
110	15221-24980	BUSH,IDLE GEAR	2	≤16028			0.02	0.044
110	16427-24280	BUSH,IDLE GEAR	1	≥16029	≠		0.08	0.176
120	15521-24360	COLLAR	1	≤16028			0.015	0.033
120	16427-24360	COLLAR	1	≥16029	≠		0.02	0.044
130	15521-24370	COLLAR	1	≤16028			0.015	0.033
130	16427-24370	COLLAR	1	≥16029	≠		0.02	0.044
140	15221-24320	CIR CLIP,IDLE GEAR	1	≤16028			0.01	0.022
140	15451-95400	CIR CLIP,IDLE GEAR	1	≥16029	≠		0.01	0.022
150	15221-24250	SHAFT,IDLE GEAR	1	≤16028			0.48	1.056
150	16427-24250	SHAFT,IDLE GEAR	1	≥16029	≠		0.65	1.43
160	01123-50818	BOLT	3				0.012	0.0264

CYLINDER HEAD

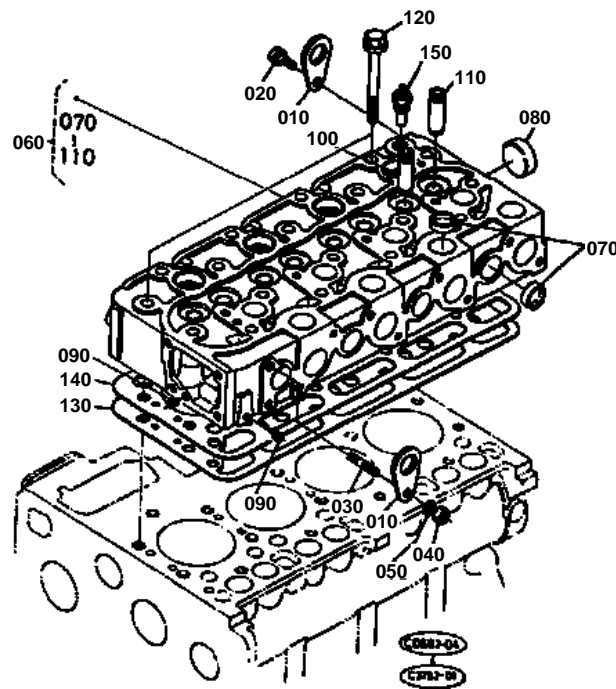



CYLINDER HEAD

↔ Interchangeable; ≠ not interchangeable; ← new for old; → old for new

REF.No	Part No.	Description	Q'ty	S.No.	I/C	REMARKS	Weight (kgf)	Weight (lb)
010	15221-01750	HOOK,ENGINE	2				0.04	0.088
020	01123-50816	BOLT	1				0.011	0.0242
030	15471-91530	STUD	2				0.01	0.022
040	02156-50080	NUT	1				0.004	0.0088
050	04512-50080	WASHER,SPRING	1				0.001	0.0022
060	15476-03043	COMP.CYLINDER HEAD	1				19.1	42.02
070	15221-03370	CAP,SEALING	12				0.01	0.022
080	15221-03490	CAP,SEALING	1				0.02	0.044
090	15261-96010	PLUG	2				0.002	0.0044
100	15521-13580	GUIDE,INLET VALVE	4	≤17412			0	0
100	17321-13580	GUIDE,INLET VALVE	4	≥17413	↔		0.015	0.033
110	17321-13560	GUIDE,EXHAUST VALVE	4				0.02	0.044
120	19202-03450	BOLT,CYLINDER HEAD	18				0.065	0.143
130	15808-03310	GASKET,CYLINDER HEAD	1	≤18067			0	0
130	15834-03310	GASKET,CYLINDER HEAD	1	≥18068	≠		0.145	0.319
140	15476-03320	SHIM,CYL.HEAD GASKET	1				0.07	0.154
150	38240-32830	SWITCH,THERMOMETER	1				0.03	0.066



VALVE, ROCKER ARM

↔ Interchangeable; ≠ not interchangeable; ← new for old; → old for new

REF.No	Part No.	Description	Q'ty	S.No.	I/C	REMARKS	Weight (kgf)	Weight (lb)
010	15221-13110	VALVE,INLET	4				0.062	0.1364
020	15221-13120	VALVE,EXHAUST	4				0.054	0.1188
030	15221-13240	SPRING,VALVE	8				0.036	0.0792
040	15221-13330	RETAINER,VALVE SP.	8				0.03	0.066
050	15221-13360	COLLET,VALVE SPRING	8			SET	0	0
060	15221-13150	SEAL,VALVE STEM	8				0.001	0.0022
070	15221-13280	CAP,VALVE	8				0.006	0.0132
080	15401-14050	ASSY SHAFT,R-ARM	1	<=18067			0.335	0.737
080	15401-14052	ASSY SHAFT,R-ARM	1	>=18068	≠		0.32	0.704
090	03410-00808	SCREW,SET	2				0.002	0.0044
100	15221-14350	BRACKET,ROCKER ARM	4				0.044	0.0968
110	15521-91500	STUD	4				0.035	0.077
120	02156-50080	NUT	4				0.004	0.0088
130	04512-50080	WASHER,SPRING	4				0.001	0.0022
140	04012-50080	WASHER,PLAIN	4				0.001	0.0022
150	15221-14420	SCREW,SET.ROCKER ARM	1	<=18067			0.003	0.0066
150	05411-00528	PIN,SPRING	1	>=18068	≠		0.003	0.0066
160	15221-14430	WASHER,R-ARM.SHAFT	2				0.002	0.0044
170	15221-14310	SPRING,ROCKER ARM	3				0.005	0.011
180	04612-00140	CIR CLIP,EXTERNAL	2				0.001	0.0022
190	15621-14030	ASSY ROCKER ARM	8				0.1	0.22
200	15521-14230	SCREW,ADJUSTING	8				0.009	0.0198
210	15021-14240	NUT	8				0.003	0.0066

CYLINDER HEAD COVER

