

# WSM

---

## WORKSHOP MANUAL DIESEL ENGINE

**EA300-E2-NB1,  
EA300-E2-NB1-APU,  
EL300-E2-AR,  
EL300-E2-AR-KCL**

---

# Kubota

# TO THE READER

This Workshop Manual has been prepared to provide servicing personnel with information on the mechanism, service and maintenance of EA / EL 300-E2 series. It is divided into three parts, "General", "Mechanism" and "Servicing".

## ■ General

Information on the engine identification, the general precautions, maintenance check list, check and maintenance and special tools are described.

## ■ Mechanism

Information on the construction and function are included. This part should be understood before proceeding with troubleshooting, disassembling and servicing.

## ■ Servicing

Information on the troubleshooting, servicing specification lists, tightening torque, checking and adjusting, disassembling and assembling, and servicing which cover procedures, precautions, factory specifications and allowable limits.

All information illustrations and specifications contained in this manual are based on the latest product information available at the time of publication.

The right is reserved to make changes in all information at any time without notice.

Due to covering many models of this manual, information or picture being used have not been specified as one model.

**March 2005**

© KUBOTA Corporation 2005

0000009759E

## SAFETY FIRST

This symbol, the industry's "Safety Alert Symbol" is used throughout this manual and on labels on the machine itself to warn of the possibility of personal injury. Read these instructions carefully. It is essential that you read the instructions and safety regulations before you attempt to repair or use this unit.

### DANGER

- Indicates an imminently hazardous situation which, if not avoided, will result in death or serious injury.

### WARNING

- Indicates a potentially hazardous situation which, if not avoided, could result in death or serious injury.

### CAUTION

- Indicates a potentially hazardous situation which, if not avoided, may result in minor or moderate injury.

### ■ IMPORTANT

- Indicates that equipment or property damage could result if instructions are not followed.

### ■ NOTE

- Gives helpful information.

0000001386E

#### BEFORE SERVICING AND REPAIRING

- Read all instructions and safety instructions in this manual and on your engine safety decals.
- Clean the work area and engine.
- Park the machine on a firm and level ground.
- Allow the engine to cool before proceeding.
- Stop the engine, and remove the key
- Disconnect the battery negative cable

0000001387E

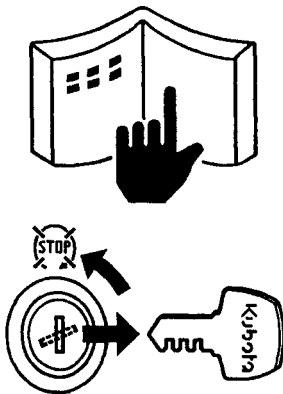

#### SAFETY STARTING

- Do not start the engine by shorting across starter terminals or bypassing the safety start switch.
- Unauthorized modifications to the engine may impair the function and / or safety and affect engine life.

0000001388E

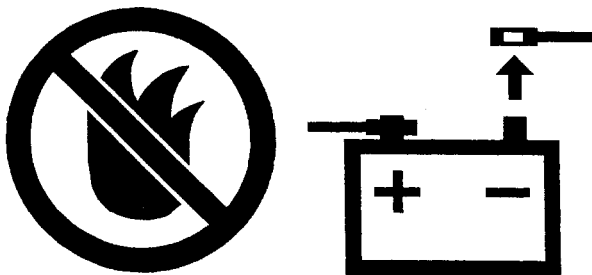
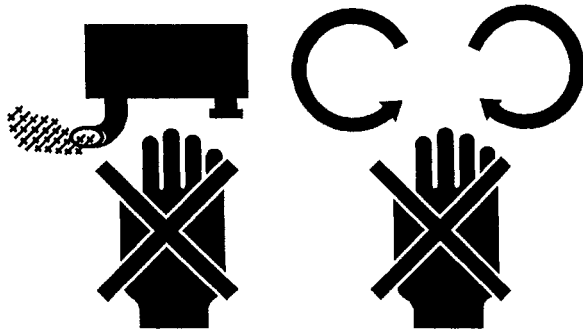

### SAFETY WORKING

- Do not work on the machine while under the influence of alcohol, medication, or other substances or while fatigued.
- Wear close fitting clothing and safety equipment appropriate to the job.
- Use tools appropriate to the work. Makeshift tools, parts, and procedures are not recommended.
- When servicing is performed together by two or more persons, take care to perform all work safely.
- Do not touch the rotating or hot parts while the engine is running.
- Never remove the radiator cap while the engine is running, or immediately after stopping. Otherwise, hot water will spout out from radiator. Only remove radiator cap when cool enough to touch with bare hands. Slowly loosen the cap to first stop to relieve pressure before removing completely.
- Escaping fluid (fuel or hydraulic oil) under pressure can penetrate the skin causing serious injury. Relieve pressure before disconnecting hydraulic or fuel lines. Tighten all connections before applying pressure.
- Wear a suitable hearing protective device such as earmuffs or earplugs to protect against objectionable or uncomfortable loud noises.

0000001389E

### AVOID FIRES

- Fuel is extremely flammable and explosive under certain conditions. Do not smoke or allow flames or sparks in your working area.
- To avoid sparks from an accidental short circuit, always disconnect the battery negative cable first and connect it last.
- Battery gas can explode. Keep sparks and open flame away from the top of battery, especially when charging the battery.
- Make sure that no fuel has been spilled on the engine.

0000001390E

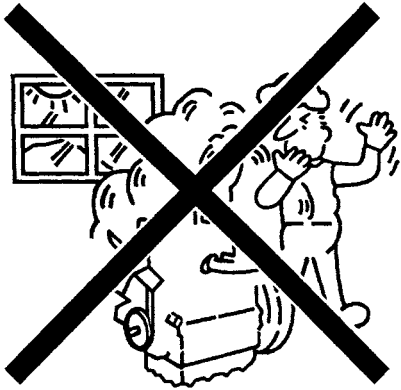
VENTILATE WORK AREA

- If the engine must be running to do some work, make sure the area is well ventilated. Never run the engine in a closed area. The exhaust gas contains poisonous carbon monoxide.

0000001391E

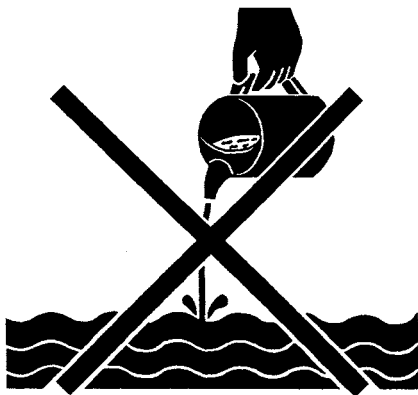
DISPOSE OF FLUIDS PROPERLY

- Do not pour fluids into the ground, down a drain, or into a stream, pond, or lake. Observe relevant environmental protection regulations when disposing of oil, fuel, coolant, electrolyte and other harmful waste.

0000001393E

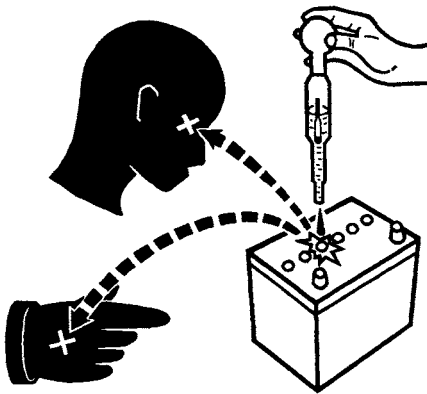
PREVENT ACID BURNS

- Sulfuric acid in battery electrolyte is poisonous. It is strong enough to burn skin, clothing and cause blindness if splashed into eyes. Keep electrolyte away from eyes, hands and clothing. If you spill electrolyte on yourself, flush with water, and get medical attention immediately.

0000001392E

PREPARE FOR EMERGENCIES

- Keep a first aid kit and fire extinguisher handy at all times.
- Keep emergency numbers for doctors, ambulance service, hospital and fire department near your telephone.

0000001394E

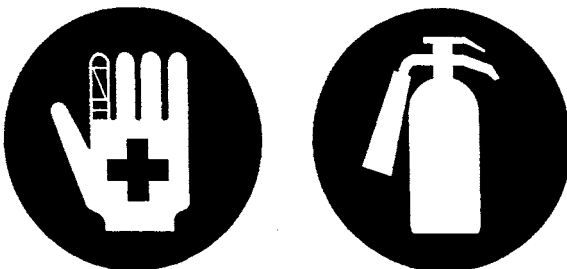

# SPECIFICATIONS

Model		EA300-E2-NB1	EA300-E2-NB1-APU
Type		Horizontal, water-cooled, 4-cycle diesel engine	
Number of Cylinder		1	
Bore x Stroke		75 mm x 70 mm	
		2.95 in x 2.76 in	
Displacement		309 cc	
		18.86 cu.in.	
Brake Horsepower	SAE Intermittent kW (PS) / rpm	5.1 (7) / 3000	
	SAE Cont. kW (PS) / rpm	4.4 (6) / 3000	
Cooling System		Radiator	
Combustion System		Spherical type (TVCS)	
Injection Timing		0.45 rad (25.5 °)	
		Before T.D.C.	
Fuel		SAE No. 2-D Light Diesel Oil	
Lubricating oil		Class CF lubricating oil as per API classification is recommended. If this class of lubricating oil is not available, preferably use Class CD or CE lubricating oil. For details on recommended lubricating oils. (see page G-5)	
Lubricating System		Forced Lubrication with Trochoid Pump	
Starting System		Electric Start	
Direction of Revolution		Counterclockwise Facing Flywheel	
Cooling Water Capacity		1.2 L (1.3 U.S.qts, 1.06 Imp.qts)	
Fuel Tank Capacity		4.8 L (1.27 U.S.qts, 1.06 Imp.qts)	
Engine Oil Capacity		1.3 L (1.4 U.S.qts, 1.14 Imp.qts)	
Dry Weight		54.0 kg (119.1 lbs)	46.0 kg (101.2 lbs)

000009760E

Model		EL300-E2-AR	EL300-E2-AR-KCL
Type		Horizontal, water-cooled, 4-cycle diesel engine	
Number of Cylinder		1	
Bore x Stroke		75 mm x 70 mm	
		2.95 in x 2.76 in	
Displacement		309 cc	
		18.86 cu.in.	
Brake Horsepower	SAE Intermittent kW (PS) / rpm	3.3 (4.5) / 2000	
	SAE Cont. kW (PS) / rpm	2.9 (4.0) / 2000	
Cooling System		Radiator	
Combustion System		Spherical type (TVCS)	
Injection Timing		0.38 rad (22 °)	
		Before T.D.C.	
Fuel		SAE No. 2-D Light Diesel Oil	
Lubricating oil		Class CF lubricating oil as per API classification is recommended. If this class of lubricating oil is not available, preferably use Class CD or CE lubricating oil. For details on recommended lubricating oils. (see page G-5)	
Lubricating System		Forced Lubrication with Trochoid Pump	
Starting System		Electric Start	
Direction of Revolution		Counterclockwise Facing Flywheel	
Cooling Water Capacity		1.2 L (1.3 U.S.qts, 1.06 Imp.qts)	
Fuel Tank Capacity		—	
Engine Oil Capacity		1.9 L (2.0 U.S.qts, 1.14 Imp.qts)	
Dry Weight		46.0 kg (101 lbs)	

000009761E

# PERFORMANCE CURVES

**EA300-E2-NB1**  
**EA300-E2-NB1-APU**

**EL300-E2-AR**  
**EL300-E2-AR-KCL**

———— Intermittent  
----- Continuous

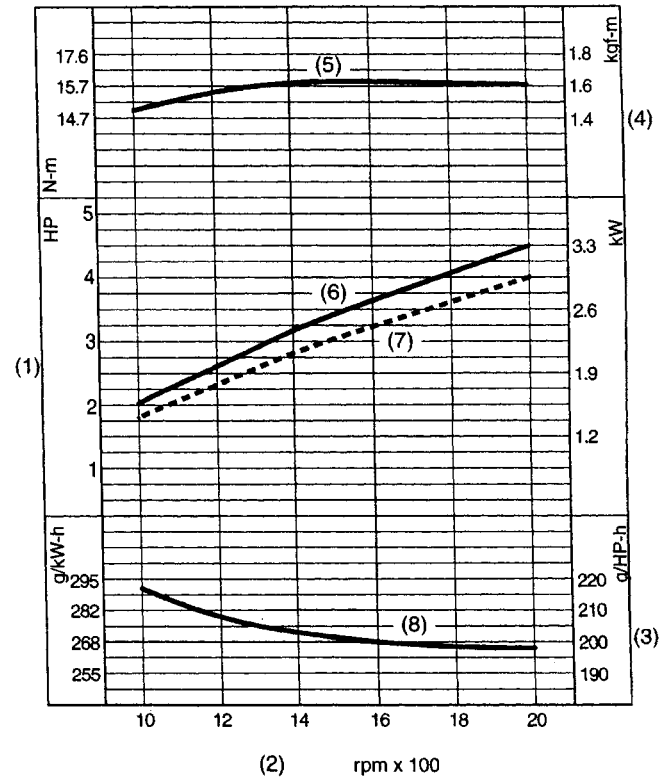
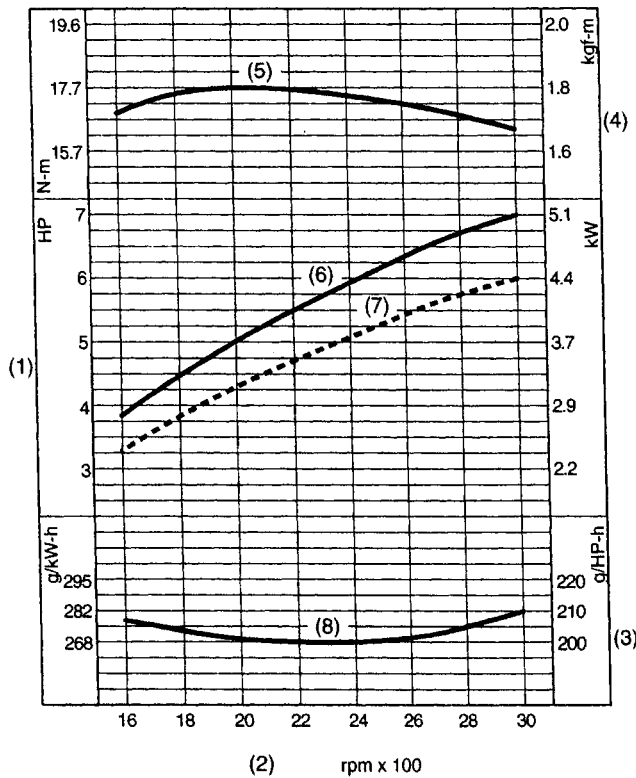

3EDAAABEP001A

- (1) Brake Horsepower
- (2) Engine Speed
- (3) Fuel Consumption
- (4) Torque
- (5) Intermittent Torque
- (6) Intermittent B.H.P.
- (7) Cont. B.H.P.
- (8) Fuel (Intermittent)

**NOTE**

- Each performance curves obtained in accordance with SAE J816b are corrected to 760 mm Hg (29.92 in. Hg), 20 °C (68 °F) 60 % humidity.

0000009762E



# DIMENSIONS

## ■ EA300-E2-NB1

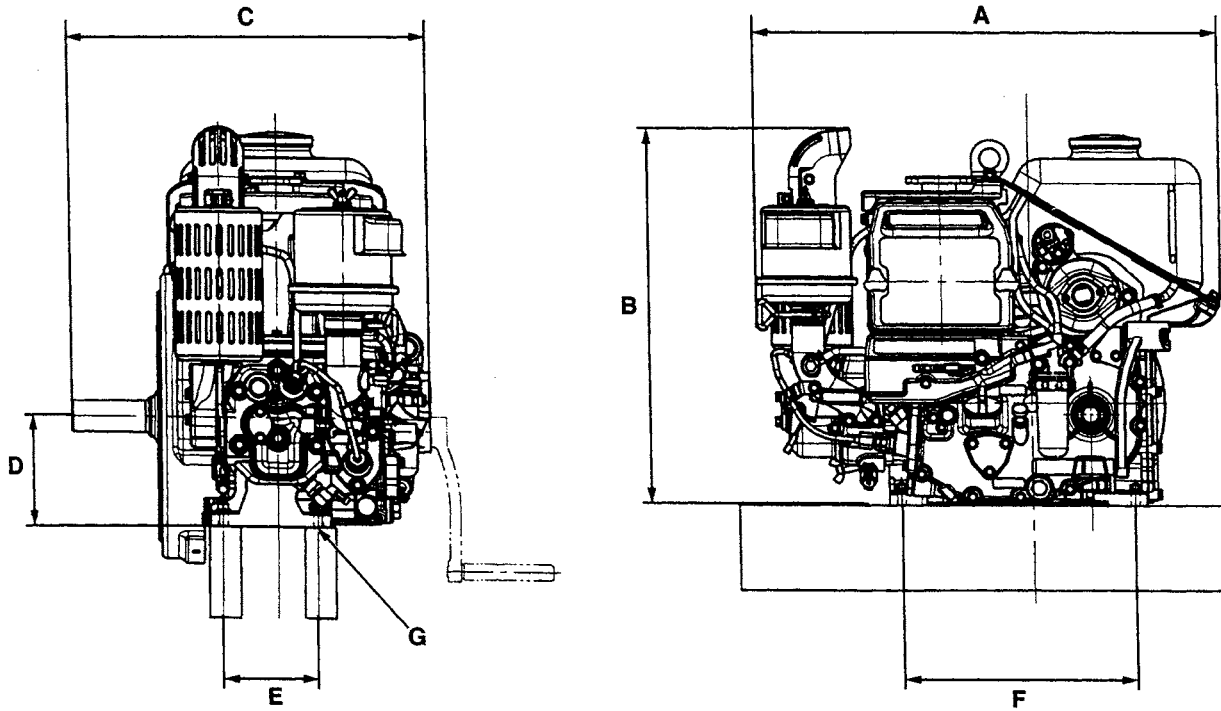

3EDAAABFP001A

A	565.5 mm (22.64 in.)
B	457 mm (17.99 in.)
C	410.4 mm (16.16 in.)
D	125 mm (4.92 in.)
E	110 mm (4.33 in.)
F	285 mm (11.22 in.)
G	φ 11 mm (0.43 in.) x 4

000009900E

■ EA300-E2-NB1-APU

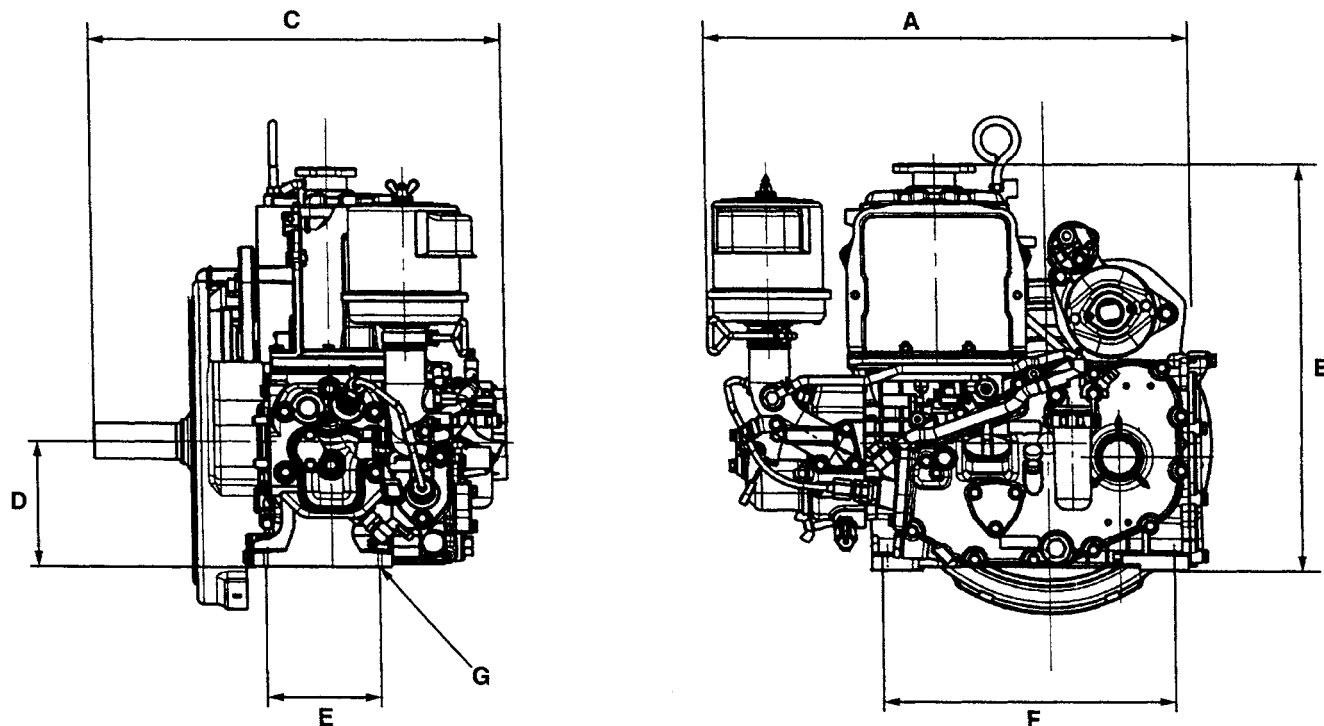

3EDAAABFP002A

A	503 mm (19.80 in.)
B	400 mm (15.75 in.)
C	410.4 mm (16.16 in.)
D	125 mm (4.92 in.)
E	110 mm (4.33 in.)
F	285 mm (11.22 in.)
G	φ 11 mm (0.43 in.) x 4

0000010023E