

KUBOTA

Workshop Manual

05 Series

Diesel Engine

TO THE READER

This Workshop Manual has been prepared to provide servicing personnel with information on the mechanism, service and maintenance of KUBOTA Diesel Engines 05 SERIES. It is divided into two parts, "Mechanism" and "Disassembling and Servicing" for each section.

■ Mechanism

Information on the construction and function are included for each engine section. This part should be understood before proceeding with troubleshooting, disassembling and servicing.

■ Disassembling and Servicing

Under the heading "General" section comes general precautions, troubleshooting, lists of servicing specifications and periodic inspection items. For each engine section, there are "Checking and Adjustment", "Disassembling and Assembling", and "Servicing" which cover procedures, precautions, factory specification and allowable limits.

All the engines that have been manufactures since January of 1994 are clean exhaust engines.

The mark [E] in the WSM refers to the said clean engine.

All information, illustrations and specifications contained in this manual are based on the latest production information available at the time of publication.

The right is reserved to make changes in all information at any time without notice.

Due to covering many models of this manual, illustration or picture being used have not been specified as one model.

May '96

© KUBOTA Corporation 1996

01640Z00040

SAFETY FIRST

This symbol, the industry's "Safety Alert Symbol", is used throughout this manual and decals on the engine itself to warn of the possibility of personal injury. Read these instructions carefully.

It is essential that you read the instructions and safety regulations before you attempt to repair or use this unit.



DANGER : Indicates an imminently hazardous situation which, if not avoided, will result in death or serious injury.



WARNING: Indicates a potentially hazardous situation which, if not avoided, could result in death or serious injury.



CAUTION : Indicates a potentially hazardous situation which, if not avoided, may result in minor or moderate injury.



IMPORTANT : Indicates that equipment or property damage could result if instructions are not followed.



NOTE : Gives helpful information.

00000Z00011

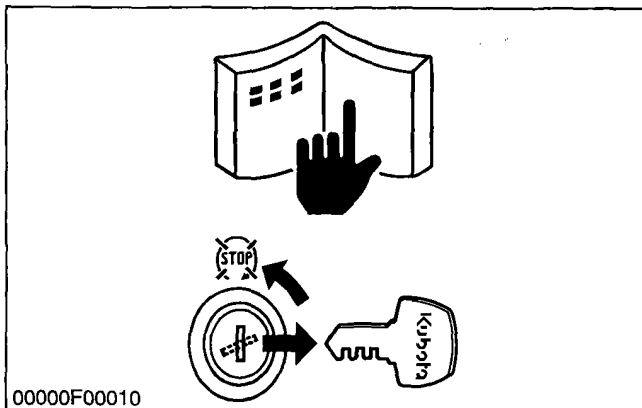

BEFORE SERVICING AND REPAIRING

- (1) Read all instructions and safety instructions in this manual and on your engine safety decals.
- (2) Clean the work area and engine.
- (3) Place the engine on a firm and level ground.
- (4) allow the engine to cool before proceeding.
- (5) Stop the engine, and remove the key.
- (6) Disconnect the battery negative cable.

00000Z00021



SAFETY STARTING

- (1) Do not start the engine by shorting across starter terminals.
- (2) Unauthorized modifications to the engine may impair the function and / or safety and affect engine life.

00000Z00031

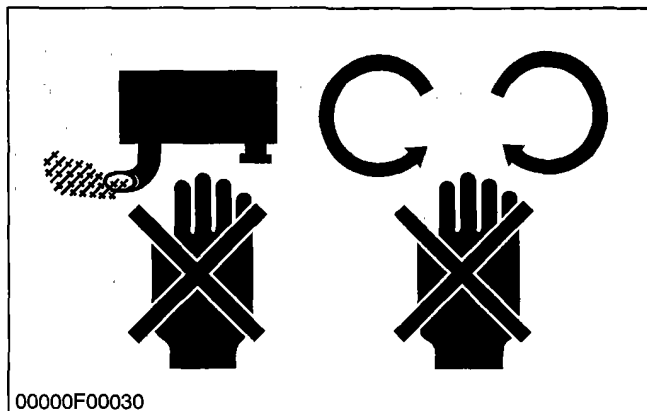

SAFETY WORKING

- (1) Do not work on the engine **while** under the influence of alcohol, medication, or **other substances** or while fatigued.
- (2) Wear close fitting clothing and safety equipment appropriate to the job.
- (3) Use tools appropriate to the work. Makeshift tools, parts, and procedures are not recommended.
- (4) When servicing is performed together by two or more persons, take care to perform all work safely.
- (5) Do not touch the rotating or hot parts while the engine is running.
- (6) Never remove the radiator cap while the engine is running, or immediately after stopping. Otherwise, hot water will spout out from radiator. Only remove radiator cap when cool enough to touch with bare hands. Slowly loosen the cap to first stop to relieve pressure before removing completely.
- (7) Escaping fluid (fuel or hydraulic oil) under pressure can penetrate the skin causing serious injury. Relieve pressure before disconnecting hydraulic or fuel lines. Tighten all connections before applying pressure.
- (8) Wear a suitable hearing protective device such as earmuffs or earplugs to protect against objectionable or uncomfortable loud noises.

00000Z00041

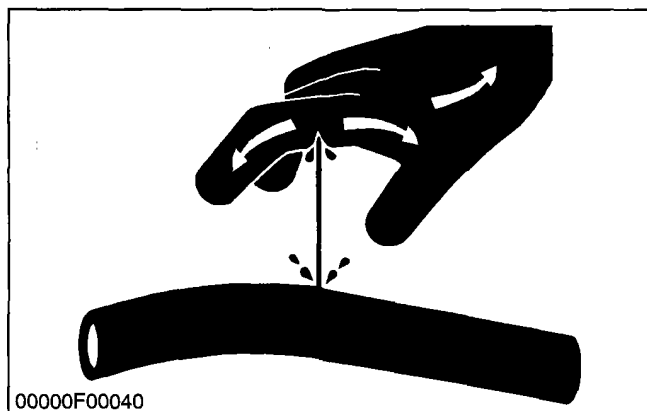

AVOID FIRES

- (1) Fuel is extremely flammable and explosive under certain conditions. Do not smoke or allow flames or sparks in your working area.
- (2) To avoid sparks from an accidental short circuit, **always** disconnect the battery negative cable first and connect it last.
- (3) Battery gas can explode. Keep sparks and open flame away from the top of battery, especially when charging the battery.
- (4) Make sure that no fuel has been spilled on the engine.

00000Z00050

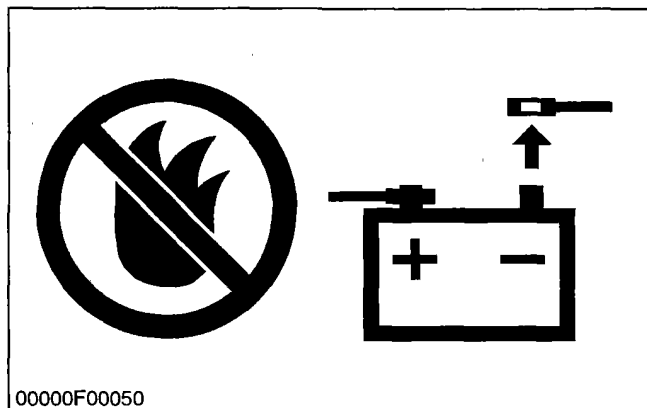

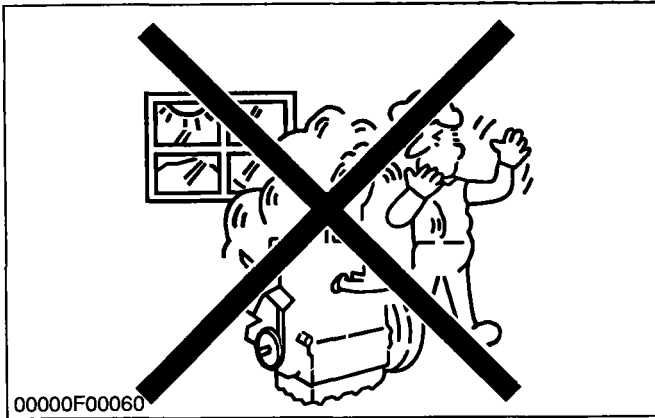

VENTILATE WORK AREA

- (1) If the engine must be running to do same work, make sure the area is well ventilated. Never run the engine in a closed area. The exhaust gas contains poisonous carbon monoxide.

00000Z00060

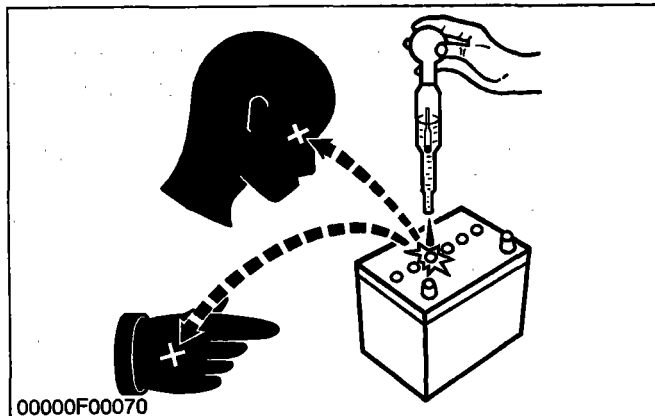

PREVENT ACID BURNS

- (1) Sulfuric acid in battery electrolyte is poisonous. It is strong enough to burn skin, clothing and cause blindness if splashed into eyes. Keep electrolyte away from eyes, hands and clothing. If you spill electrolyte on yourself, flush with water, and get medical attention immediately.

00000Z00070

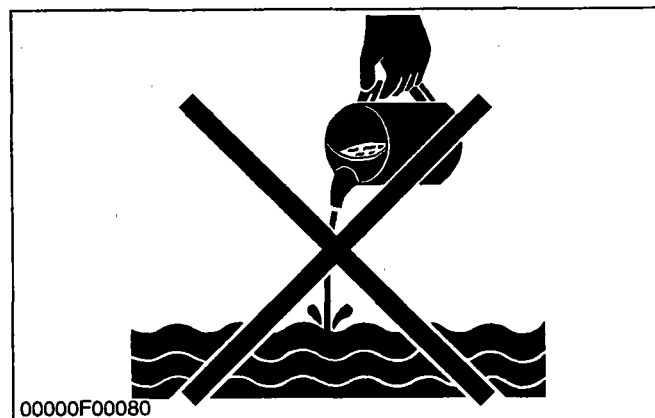

DISPOSE OF FLUIDS PROPERLY

- (1) Do not pour fluids into the ground, down a drain, or into a stream, pond, or lake. Observe relevant environmental protection regulations when disposing of oil, fuel, coolant, electrolyte and other harmful waste.

00000Z00080



PREPARE FOR EMERGENCIES

- (1) Keep a first aid kit and fire extinguisher handy at all times.
- (2) Keep emergency numbers for doctors, ambulance service, hospital and fire department near your telephone.

00000Z00090

SPECIFICATIONS

Model		D905-B (E)		D1005-B (E)		V1205-B (E)		V1205-T-B (E)		V1305-B (E)		
Number of cylinders		3				4						
Type		Vertical, water-cooled, 4-cycle diesel engine										
Bore x stroke mm (in.)		72 x 73.6 (2.83 x 2.90)		76 x 73.6 (2.99 x 2.90)		72 x 73.6 (2.83 x 2.90)				76 x 73.6 (2.99 x 2.90)		
Total displacement cm ³ (cu. in.)		898 (54.86)		1001 (61.08)		1198 (73.10)				1335 (81.46)		
Brake Horsepower	SAE net cont.	kW/rpm (HP/rpm)	12.7/3000 (17.0/3000)	15.3/3600 (20.5/3600)	14.2/3000 (19.0/3000)	16.8/3600 (22.5/3600)	17.2/3000 (23.0/3000)	20.1/3600 (27.0/3600)	21.6/3000 (29.0/3000)	25.7/3600 (34.5/3600)	19.0/3000 (25.5/3000)	22.4/3600 (30.0/3600)
	SAE net intermittent	kW/rpm (HP/rpm)	14.9/3000 (20.0/3000)	17.5/3600 (23.5/3600)	16.8/3000 (22.5/3000)	19.4/3600 (26.0/3600)	20.1/3000 (27.0/3000)	23.5/3600 (31.5/3600)	25.4/3000 (34.0/3000)	29.8/3600 (40.0/3600)	22.4/3000 (30.0/3000)	25.7/3600 (34.5/3600)
	SAE gross intermittent	kW/rpm (HP/rpm)	16.8/3000 (22.5/3000)	19.4/3600 (26.0/3600)	18.7/3000 (25.0/3000)	21.6/3600 (29.0/3600)	22.4/3000 (30.0/3000)	26.1/3600 (35.0/3600)	28.0/3000 (37.5/3000)	32.8/3600 (44.0/3600)	25.0/3000 (33.5/3000)	28.7/3600 (38.5/3600)
	DIN6271-NA	kW/rpm (ps/rpm)	12.5/3000 (17.0/3000)	15.1/3600 (20.5/3600)	14.0/3000 (19.0/3000)	16.5/3600 (22.5/3000)	16.9/3000 (23.0/3000)	19.9/3600 (27.0/3600)	21.3/3000 (29.0/3000)	25.4/3600 (34.5/3600)	18.8/3000 (25.5/3000)	22.1/3600 (30.0/3600)
	DIN6271-NB	kW/rpm (ps/rpm)	14.3/3000 (19.5/3000)	16.5/3600 (22.5/3600)	15.8/3000 (21.5/3000)	18.4/3600 (25.0/3600)	19.1/3000 (26.0/3000)	22.1/3600 (30.0/3600)	24.3/3000 (33.0/3000)	28.3/3600 (38.5/3600)	21.3/3000 (29.0/3000)	24.6/3600 (33.5/3600)
	DIN70020	kW/rpm (ps/rpm)	15.4/3000 (21.0/3000)	18.4/3600 (25.0/3600)	17.3/3000 (23.5/3000)	20.2/3600 (27.5/3600)	21.0/3000 (28.5/3000)	24.3/3600 (33.0/3600)	26.5/3000 (36.0/3000)	31.3/3600 (42.5/3600)	23.2/3000 (31.5/3000)	26.8/3600 (36.5/3600)
Maximum bare speed rpm		3200	3800	3200	3800	3200	3800	3200	3800	3200	3800	
Minimum idling speed rpm		600										
Maximum torque		N·m/rpm kgf·m/rpm ft·lbs/rpm	53.8/2000 5.49/2000 39.71/2000	52.8/2400 5.38/2400 38.91/2400	60.6/2000 6.18/2000 44.7/2000	58.4/2400 5.95/2400 43.0/2400	72.7/2000 7.41/2000 53.60/2000	70.7/2400 7.21/2400 52.15/2400	91.5/2000 9.33/2000 67.48/2000	89.7/2400 9.15/2400 66.18/2400	80.8/2000 8.24/2000 59.60/2000	77.4/2400 7.89/2400 57.07/2400
Combustion Chamber		Spherical type										
Fuel injection pump		Bosch MD type mini pump										
Governor		Centrifugal mechanical governor										
Direction of rotation		Counter-clockwise (viewed from flywheel side)										
Injection nozzle		Mini nozzle (DNOPI)										
Injection timing	Without timer	18 to 20° (0.31 to 0.35 rad.) before T.D.C.	21 to 23° (0.37 to 0.40 rad.) before T.D.C.	18 to 20° (0.31 to 0.35 rad.) before T.D.C.	21 to 23° (0.37 to 0.40 rad.) before T.D.C.	18 to 20° (0.31 to 0.35 rad.) before T.D.C.	21 to 23° (0.37 to 0.40 rad.) before T.D.C.	18 to 20° (0.31 to 0.35 rad.) before T.D.C.	21 to 23° (0.37 to 0.40 rad.) before T.D.C.	18 to 20° (0.31 to 0.35 rad.) before T.D.C.	21 to 23° (0.37 to 0.40 rad.) before T.D.C.	
	With timer	8 to 10° (0.14 to 0.17 rad.) before T.D.C.	9 to 11° (0.16 to 0.19 rad.) before T.D.C.	8 to 10° (0.14 to 0.17 rad.) before T.D.C.	9 to 11° (0.16 to 0.19 rad.) before T.D.C.	8 to 10° (0.14 to 0.17 rad.) before T.D.C.	9 to 11° (0.16 to 0.19 rad.) before T.D.C.	8 to 10° (0.14 to 0.17 rad.) before T.D.C.	9 to 11° (0.16 to 0.19 rad.) before T.D.C.	8 to 10° (0.14 to 0.17 rad.) before T.D.C.	9 to 11° (0.16 to 0.19 rad.) before T.D.C.	
Firing order		1-2-3				1-3-4-2						
Injection pressure		140 kgf/cm ² (13.73 MPa, 1991 psi)										
Compression ratio		22 : 1										
Lubricating system		Forced lubrication by pump										
Oil pressure indicating		Electrical type switch										
Lubricating filter		Full flow paper filter (cartridge type)										
Cooling system		Pressurized radiator, forced circulation with water pump (not included in the basic engine)										
Starting system		Electric starting with starter										
Starting support device		12 V, 0.9 kW	12 V, 1.0 kW			12 V, 1.2 kW						
Battery		12 V, 65 AH, equivalent				12 V, 70 AH, equivalent						
Dynamo for charging		12 V, 150 W	12 V, 360 W									
Fuel		Diesel fuel No. 2-D (ASTM D975)										
Lubricating oil		MIL-L-46152, MIL-L-2104C, quality better than CD class (API)						Quality better than CE class (API)		Quality better than CD class (API)		
Lubricating oil capacity	125 mm (4.92 in.)	5.1 L (5.39 U.S.qts., 4.49 Imp.qts.)				6.0 L (6.34 U.S.qts., 5.28 Imp.qts.)		6.7 L (7.08 U.S.qts., 5.90 Imp.qts.)		6.0 L (6.34 U.S.qts., 5.28 Imp.qts.)		
	101 mm (3.97 in.)	4.0 L (4.23 U.S.qts., 3.52 Imp.qts.)				4.7 L (4.97 U.S.qts., 4.14 Imp.qts.)		—		4.7 L (4.97 U.S.qts., 4.14 Imp.qts.)		
Weight (Dry) kg (lbs)		93.0 (205.0)				110.0 (242.5)		114.0 (251.3)		110.0 (242.5)		

01640Z00070

Model		D1105-B (E)	V1505-B (E)	D1105-T-B (E)	V1505-T-B (E)
Number of cylinders		3	4	3	4
Type		Vertical, water-cooled, 4-cycle diesel engine			
Bore x stroke mm (in.)		78 x 78.4 (3.07 x 3.09)			
Total displacement cm ³ (cu. in.)		1123 (68.53)	1498 (91.41)	1123 (68.53)	1498 (91.41)
Brake horsepower	SAE net cont. kW/rpm (HP/rpm)	16.4/3000 (22.0/3000)	21.6/3000 (29.0/3000)	20.5/3000 (27.5/3000)	27.2/3000 (36.5/3000)
	SAE net intermittent kW/rpm (HP/rpm)	18.7/3000 (25.0/3000)	25.0/3000 (33.5/3000)	23.5/3000 (31.5/3000)	31.3/3000 (42.0/3000)
	SAE gross intermittent kW/rpm (HP/rpm)	20.9/3000 (28.0/3000)	28.0/3000 (37.5/3000)	26.1/3000 (35.0/3000)	34.7/3000 (46.5/3000)
	DIN6271-NA kW/rpm (ps/rpm)	16.2/3000 (22.0/3000)	21.3/3000 (29.0/3000)	20.2/3000 (27.5/3000)	26.8/3000 (36.5/3000)
	DIN6271-NB kW/rpm (ps/rpm)	17.6/3000 (24.0/3000)	23.5/3000 (32.0/3000)	22.4/3000 (30.5/3000)	29.8/3000 (40.5/3000)
	DIN70020 kW/rpm (ps/rpm)	19.5/3000 (26.5/3000)	26.1/3000 (35.5/3000)	24.6/3000 (33.5/3000)	32.7/3000 (44.5/3000)
Maximum bare speed rpm		3200			
Minimum idling speed rpm		850 to 950			
Maximum torque N·m/rpm kgf·m/rpm ft·lbs/rpm		68.3/2000 6.96/2000 50.3/2000	91.5/2000 9.33/2000 67.5/2000	86.0/2000 8.77/2000 63.4/2000	114.7/2000 11.7/2000 84.6/2000
Combustion chamber		Spherical type (E-TVCE)			
Fuel injection pump		Bosch MD type mini pump			
Governor		Centrifugal mechanical governor			
Direction of rotation		Counter-clockwise (viewed from flywheel side)			
Injection nozzle		Mini nozzle (DNOPD)			
Injection timing	Without timer	0.31 to 0.35 rad. (18 to 20°) before T.D.C.			
	With timer	0.14 to 0.17 rad. (8 to 10°) before T.D.C.	0.21 to 0.24 rad. (12 to 14°) before T.D.C.	0.14 to 0.17 rad. (8 to 10°) before T.D.C.	
Firing order		1-2-3	1-3-4-2	1-2-3	1-3-4-2
Injection pressure		13.73 MPa (140 kgf/cm ² , 1991 psi)			
Compression ratio		22 : 1		22.5 : 1	
Lubricating system		Forced lubrication by pump			
Oil pressure indicating		Electrical type switch			
Lubricating filter		Full flow paper filter (cartridge type)			
Cooling system		Pressurized radiator, forced circulation with water pump (not included in the basic engine)			
Starting system		Electric starting with starter			
		12 V, 1.0 kW	12 V, 1.2 kW	12 V, 1.0 kW	12 V, 1.2 kW
Starting support device		By glow plug in combustion chamber			
Battery		12 V, 65 AH, equivalent	12 V, 70 AH, equivalent	12 V, 65 AH, equivalent	12 V, 56 AH
Dynamo for charging		12 V, 360 W			
Fuel		Diesel fuel No. 2-D (ASTM D975)			
Lubricating oil		MIL-L-46152, MIL-L-2104C, quality better than CD class (API)		Quality better than CE class (API)	
Lubricating oil capacity	125 mm (4.92 in.)	5.1 L (5.39 U.S.qts., 4.49 Imp.qts.)	6.0 L (6.34 U.S.qts., 5.28 Imp.qts.)	5.1 L (5.39 U.S.qts., 4.49 Imp.qts.)	6.7 L (7.08 U.S.qts., 5.90 Imp.qts.)
	101 mm (3.97 in.)	4.0 L (4.23 U.S.qts., 3.52 Imp.qts.)	4.7 L (4.97 U.S.qts., 4.14 Imp.qts.)	4.0 L (4.23 U.S.qts., 3.52 Imp.qts.)	-
Weight (Dry) kg (lbs)		93.0 (205.0)	110.0 (242.5)	97.0 (213.8)	114.0 (251.3)

01640Z00100

MECHANISM

CONTENTS

■	FEATURE	M-1
■	ENGINE BODY	M-3
	[1] CYLINDER BLOCK.....	M-3
	[2] CYLINDER HEAD.....	M-3
	[3] CRANKSHAFT.....	M-5
	[4] PISTON AND PISTON RINGS	M-5
	[5] CONNECTING ROD.....	M-7
	[6] ROCKER ARM.....	M-7
	[7] CAMSHAFT	M-7
	[8] FUEL CAMSHAFT	M-9
	[9] FLYWHEEL.....	M-9
■	LUBRICATING SYSTEM.....	M-11
	[1] GENERAL.....	M-11
	[2] OIL PUMP.....	M-13
	[3] RELIEF VALVE.....	M-13
	[4] OIL FILTER CARTRIDGE.....	M-15
	[5] OIL PRESSURE SWITCH	M-15
■	COOLING SYSTEM.....	M-17
	[1] GENERAL.....	M-17
	[2] WATER PUMP.....	M-17
	[3] THERMOSTAT	M-19
	[4] RADIATOR (not included in the basic engine).....	M-19
	[5] RADIATOR CAP	M-21
■	INTAKE / EXHAUST SYSTEM	M-23
	[1] AIR CLEANER (not included in the basic engine)	M-23
	[2] MUFFLER (not included in the basic engine)	M-23
■	FUEL SYSTEM.....	M-25
	[1] GENERAL.....	M-25
	[2] INJECTION PUMP.....	M-25
	(1) Pump Element.....	M-27
	(2) Delivery Valve	M-27
	(3) Dumping Valve.....	M-29
	(4) Injection Control	M-29
	[3] INJECTION NOZZLE.....	M-31
	[4] FUEL FILTER (not included in the basic model).....	M-31
	[5] GOVERNOR.....	M-33
	[6] AUTOMATIC ADVANCE TIMER (not included in the basic model)	M-37
■	ELECTRICAL SYSTEM.....	M-41
	[1] CHARGING SYSTEM.....	M-41
	(1) Alternator.....	M-41
	(2) IC Regulator	M-41
■	TURBO CHARGER SYSTEM.....	M-43
	(1) Mechanism.....	M-45
	(2) Turbine	M-47
	(3) Compressor.....	M-47
	(4) Bearing.....	M-49
	(5) Seals (Piston Rings).....	M-51

F FEATURE

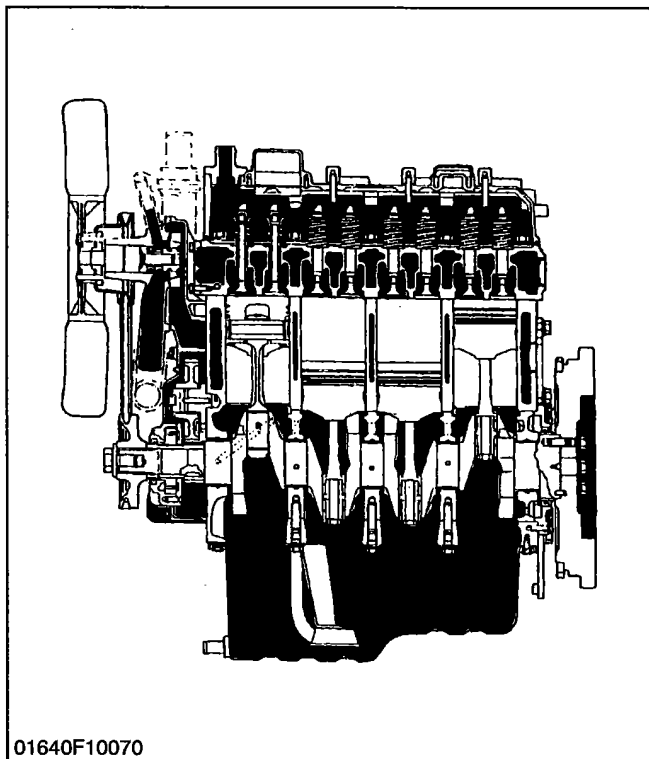

The 05 SERIES ENGINE are vertical, water-cooled, 4 cycle diesel engines.

They are incorporated KUBOTA's foremost technologies. With KUBOTA's E-TVCS (Three Vortex Combustion System), well-known Bosch MD type injection pump and the well-balanced designs, they give greater power, low fuel consumption, little vibration and quiet operation.

■ NOTE

- Since January 1994, E-TVCS has been used for the combustion chamber of our products instead of traditional N-TVCS.

E-TVCS was developed with an eye toward clean exhaust gas which is more environmentally freindly.

The combustion chamber models mentioned hereinafter refers to E-TVCS.

Model of combustion chamber :

N-TVCS

(Engine Serial Number ; 489290 or lower)

E-TVCS

(Engine Serial Number ; 489291 or higher)

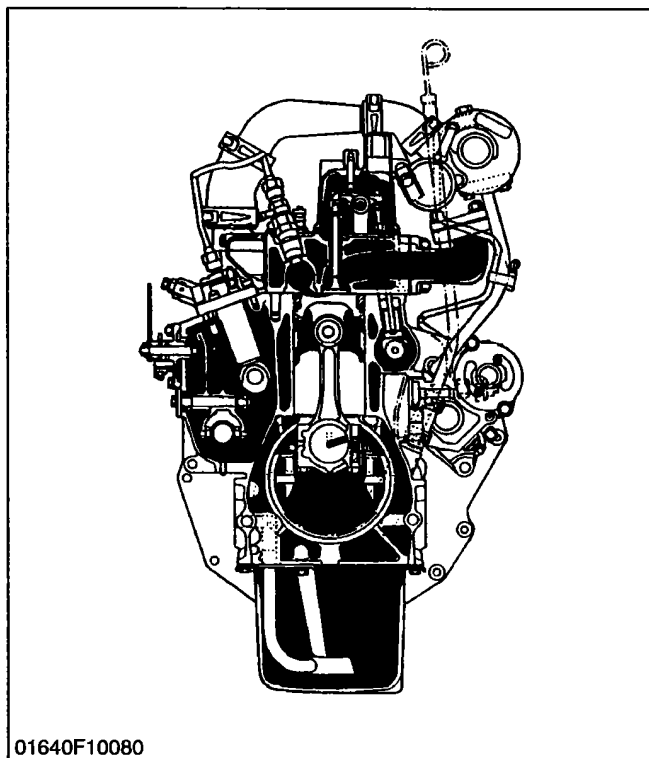

11900M10011