

SHOP
MANUAL
KOMATSU
WA 70-1

MACHINE MODEL SERIAL No.

WA 70-1 **10001 and up**



CONTENTS

	No. of page
10 ENGINE	
12 TESTING AND ADJUSTING	12-1
13 DISASSEMBLY AND ASSEMBLY	13-1
20 POWER TRAIN	
21 STRUCTURE AND FUNCTION	21-1
22 TESTING AND ADJUSTING	22-1
23 DISASSEMBLY AND ASSEMBLY	23-1
24 MAINTENANCE STANDARD	24-1
40 STEERING SYSTEM	
41 STRUCTURE AND FUNCTION	41-1
42 TESTING AND ADJUSTING	42-1
43 DISASSEMBLY AND ASSEMBLY	43-1
44 MAINTENANCE STANDARD	44-1
50 BRAKE SYSTEM	
51 STRUCTURE AND FUNCTION	51-1
52 TESTING AND ADJUSTING	52-1
53 DISASSEMBLY AND ASSEMBLY	53-1
54 MAINTENANCE STANDARD	54-1
60 WORK EQUIPMENT	
61 STRUCTURE AND FUNCTION	61-1
62 TESTING AND ADJUSTING	62-1
63 DISASSEMBLY AND ASSEMBLY	63-1
64 MAINTENANCE STANDARD	64-1
80 ELECTRICAL SYSTEM	
81 STRUCTURE AND FUNCTION	81-1
83 DISASSEMBLY AND ASSEMBLY	83-1



IMPORTANT SAFETY NOTICE

Proper service and repair is extremely important for the safe operation of your machine. The service and repair techniques recommended by Komatsu and described in this manual are both effective and safe methods of operation. Some of these operations require the use of tools specially designed by Komatsu for the purpose.

To prevent injury to workers, the symbols  and  are used to mark safety precautions in this manual. The cautions accompanying these symbols should always be followed carefully. If any dangerous situation arises or may possibly arise, first consider safety, and take the necessary actions to deal with the situation.



SAFETY

GENERAL PRECAUTIONS

Mistakes in operation are extremely dangerous. Read the Operation and Maintenance Manual carefully BEFORE operating the machine.

1. Before carrying out any greasing or repairs, read all the precautions given on the decals which are fixed to the machine.
2. When carrying out any operation, always wear safety shoes and helmet. Do not wear loose work clothes, or clothes with buttons missing.
 - Always wear safety glasses when hitting parts with a hammer.
 - Always wear safety glasses when grinding parts with a grinder, etc.
3. If welding repairs are needed, always have a trained, experienced welder carry out the work. When carrying out welding work, always wear welding gloves, apron, glasses, cap and other clothes suited for welding work.
4. When carrying out any operation with two or more workers, always agree on the operating procedure before starting. Always inform your fellow workers before starting any step of the operation. Before starting work, hang UNDER REPAIR signs on the controls in the operator's compartment.
5. Keep all tools in good condition and learn the correct way to use them.

6. Decide a place in the repair workshop to keep tools and removed parts. Always keep the tools and parts in their correct places. Always keep the work area clean and make sure that there is no dirt or oil on the floor. Smoke only in the areas provided for smoking. Never smoke while working.

PREPARATIONS FOR WORK

7. Before adding oil or making any repairs, park the machine on hard, level ground, and block the wheels or tracks to prevent the machine from moving.
8. Before starting work, lower blade, ripper, bucket or any other work equipment to the ground. If this is not possible, insert the safety pin or use blocks to prevent the work equipment from falling. In addition, be sure to lock all the control levers and hang warning signs on them.
9. When disassembling or assembling, support the machine with blocks, jacks or stands before starting work.
10. Remove all mud and oil from the steps or other places used to get on and off the machine. Always use the handrails, ladders or steps when getting on or off the machine. Never jump on or off the machine. If it is impossible to use the handrails, ladders or steps, use a stand to provide safe footing.

PRECAUTIONS DURING WORK

11. When removing the oil filler cap, drain plug or hydraulic pressure measuring plugs, loosen them slowly to prevent the oil from spurting out.
Before disconnecting or removing components of the oil, water or air circuits, first remove the pressure completely from the circuit.
12. The water and oil in the circuits are hot when the engine is stopped, so be careful not to get burned.
Wait for the oil and water to cool before carrying out any work on the oil or water circuits.
13. Before starting work, remove the leads from the battery. Always remove the lead from the negative (–) terminal first.
14. When raising heavy components, use a hoist or crane.
Check that the wire rope, chains and hooks are free from damage.
Always use lifting equipment which has ample capacity.
Install the lifting equipment at the correct places. Use a hoist or crane and operate slowly to prevent the component from hitting any other part. Do not work with any part still raised by the hoist or crane.
15. When removing covers which are under internal pressure or under pressure from a spring, always leave two bolts in position on opposite sides. Slowly release the pressure, then slowly loosen the bolts to remove.
16. When removing components, be careful not to break or damage the wiring. Damaged wiring may cause electrical fires.
17. When removing piping, stop the fuel or oil from spilling out. If any fuel or oil drips on to the floor, wipe it up immediately. Fuel or oil on the floor can cause you to slip, or can even start fires.
18. As a general rule, do not use gasoline to wash parts. In particular, use only the minimum of gasoline when washing electrical parts.
19. Be sure to assemble all parts again in their original places.
Replace any damaged parts with new parts.
 - When installing hoses and wires, be sure that they will not be damaged by contact with other parts when the machine is being operated.
20. When installing high pressure hoses, make sure that they are not twisted. Damaged tubes are dangerous, so be extremely careful when installing tubes for high pressure circuits. Also, check that connecting parts are correctly installed.
21. When assembling or installing parts, always use the specified tightening torques. When installing protective parts such as guards, or parts which vibrate violently or rotate at high speed, be particularly careful to check that they are installed correctly.
22. When aligning two holes, never insert your fingers or hand. Be careful not to get your fingers caught in a hole.
23. When measuring hydraulic pressure, check that the measuring tool is correctly assembled before taking any measurements.
24. Take care when removing or installing the tracks of track-type machines.
When removing the track, the track separates suddenly, so never let anyone stand at either end of the track.

FOREWORD

This shop manual has been prepared as an aid to improve the quality of repairs by giving the serviceman an accurate understanding of the product and by showing him the correct way to perform repairs and make judgements. Make sure you understand the contents of this manual and use it to full effect at every opportunity.

This shop manual mainly contains the necessary technical information for operations performed in a service workshop.

For ease of understanding, the manual is divided into chapters for each main group of components; these chapters are further divided into the following sections.

STRUCTURE AND FUNCTION

This section explains the structure and function of each component. It serves not only to give an understanding of the structure, but also serves as reference material for troubleshooting.

TESTING AND ADJUSTING

This section explains checks to be made before and after performing repairs, as well as adjustments to be made at completion of the checks and repairs.

Troubleshooting charts correlating "Problems" to "Causes" are also included in this section.

DISASSEMBLY AND ASSEMBLY

This section explains the order to be followed when removing, installing, disassembling or assembling each component, as well as precautions to be taken for these operations.

MAINTENANCE STANDARD

This section gives the judgement standards when inspecting disassembled parts.

NOTICE

The specifications contained in this shop manual are subject to change at any time and without any advance notice. Contact your KOMATSU distributor for the latest information.

HOW TO READ THE SHOP MANUAL

VOLUMES

Shop manuals are issued as a guide to carrying out repairs. They are divided as follows:

- Chassis volume:** Issued for every machine model
- Engine volume:** Issued for each engine series
- Electrical volume** : } Each issued as one
- Attachments volume** : } volume to cover all models

These various volumes are designed to avoid duplicating the same information. Therefore to deal with all repairs for any model, it is necessary that chassis, engine, electrical and attachment volumes are ready.

DISTRIBUTION AND UPDATING

Any additions, amendments or other changes will be sent to KOMATSU distributors. Get the most up-to-date information before you start any work.

FILING METHOD

1. See the page number on the bottom of the page. File the pages in correct order.
2. Following examples show how to read the page number.

Example 1 (Chassis volume):

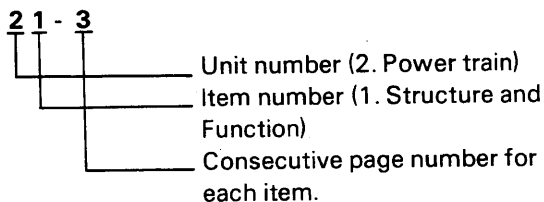

Example 2 (Engine volume):

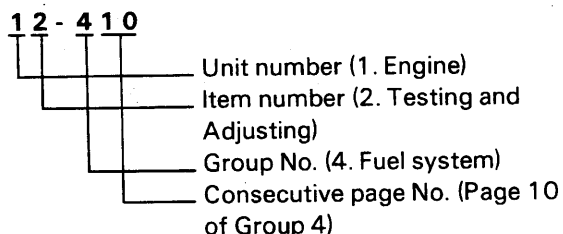

3. Additional pages: Additional pages are indicated by a hyphen (-) and number after the page number. File as in the example.

Example:

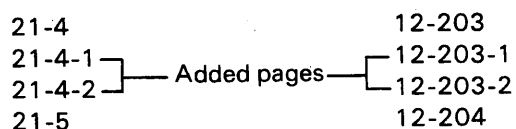

REVISED EDITION MARK (① ② ③....)

When a manual is revised, an edition mark is recorded on the bottom outside corner of the pages.

REVISIONS

Revised pages are shown at the LIST OF REVISED PAGES on the between the title page and SAFETY page.

SYMBOLS

So that the shop manual can be of ample practical use, important places for safety and quality are marked with the following symbols.

Symbol	Item	Remarks
	Safety	Special safety precautions are necessary when performing the work.
		Extra special safety precautions are necessary when performing the work because it is under internal pressure.
	Caution	Special technical precautions or other precautions for preserving standards are necessary when performing the work.
	Weight	Weight of parts or systems. Caution necessary when selecting hoisting wire, or when working posture is important, etc.
	Tightening torque	Places that require special attention for the tightening torque during assembly.
	Coat	Places to be coated with adhesives and lubricants etc.
	Oil, water	Places where oil, water or fuel must be added, and the capacity.
	Drain	Places where oil or water must be drained, and quantity to be drained.

HOISTING INSTRUCTIONS

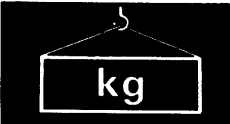

! Heavy parts (25 kg or more) must be lifted with a hoist etc. In the **Disassembly and Assembly** section, every part weighing 25 kg or more is indicated clearly with the symbol 

- If a part cannot be smoothly removed from the machine by hoisting, the following checks should be made:
 - Check for removal of all bolts fastening the part to the relative parts.
 - Check for existence of another part causing interference with the part to be removed.

2. Wire ropes

- Use adequate ropes depending on the weight of parts to be hoisted, referring to the table below:

Wire ropes (Standard "Z" or "S" twist ropes without galvanizing)	
Rope diameter (mm)	Allowable load (tons)
10	1.0
11.2	1.4
12.5	1.6
14	2.2
16	2.8
18	3.6
20	4.4
22.4	5.6
30	10.0
40	18.0
50	28.0
60	40.0

The allowable load value is estimated to be one-sixth or one-seventh of the breaking strength of the rope used.

- Sling wire ropes from the middle portion of the hook.

Slinging near the edge of the hook may cause the rope to slip off the hook during hoisting, and a serious accident can result. Hooks have maximum strength at the middle portion.

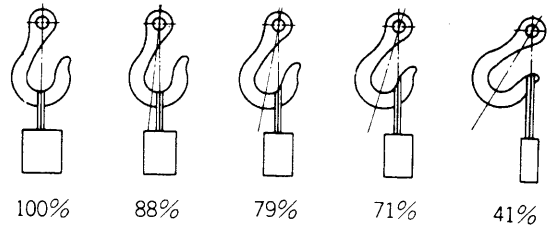

FS0064

- Do not sling a heavy load with one rope alone, but sling with two or more ropes symmetrically wound on to the load.
 - !** Slinging with one rope may cause turning of the load during hoisting, untwisting of the rope, or slipping of the rope from its original winding position on the load, which can result in a dangerous accident.

- Do not sling a heavy load with ropes forming a wide hanging angle from the hook. When hoisting a load with two or more ropes, the force subjected to each rope will increase with the hanging angles. The table below shows the variation of allowable load (kg) when hoisting is made with two ropes, each of which is allowed to sling up to 1000 kg vertically, at various hanging angles. When two ropes sling a load vertically, up to 2000 kg of total weight can be suspended. This weight becomes 1000 kg when two ropes make a 120° hanging angle. On the other hand, two ropes are subjected to an excessive force as large as 4000 kg if they sling a 2000 kg load at a lifting angle of 150°.

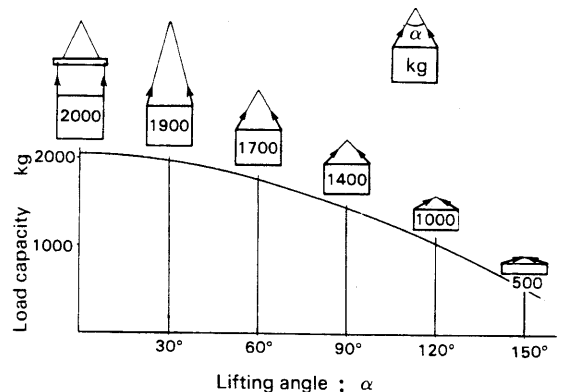



FS0065



STANDARD TIGHTENING TORQUE

1. STANDARD TIGHTENING TORQUE OF BOLTS AND NUTS

The following charts give the standard tightening torques of bolts and nuts. Exceptions are given in sections of "Disassembly and Assembly".

Thread diameter of bolt (mm)	Width across flat (mm)		
		kgm	Nm
6	10	1.35±0.15	13.2±1.4
8	13	3.2±0.3	31.4±2.9
10	17	6.7±0.7	65.7±6.8
12	19	11.5±1.0	112±9.8
14	22	18.0±2.0	177±19
16	24	28.5±3	279±29
18	27	39±4	383±39
20	30	56±6	549±58
22	32	76±8	745±78
24	36	94.5±10	927±98
27	41	135±15	1320±140
30	46	175±20	1720±190
33	50	225±25	2210±240
36	55	280±30	2750±290
39	60	335±35	3280±340

This torque table does not apply to the bolts with which nylon packings or other non-ferrous metal washers are to be used, or which require tightening to otherwise specified torque.

★ Nm (newton meter): 1Nm ≙ 0.1 kgm

2. TIGHTENING TORQUE OF SPLIT FLANGE BOLTS

Use these torques for split flange bolts.

Thread diameter of bolt (mm)	Width across flats (mm)	Tightening torque	
		kgm	Nm
10	14	6.7±0.7	65.7±6.8
12	17	11.5±1	112±9.8
16	22	28.5±3	279±29

STANDARD TIGHTENING TORQUE



3. TIGHTENING TORQUE FOR NUTS OF FLARED

Use these torques for nut part of flared.

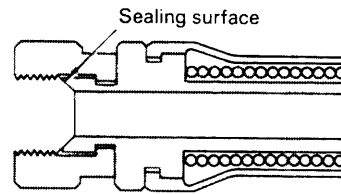

FS0068

Thread diameter of nut part (mm)	Width across flats of nut part (mm)	Tightening torque	
		kgm	Nm
14	19	2.5 ± 0.5	24.5 ± 4.9
18	24	5 ± 2	49 ± 19.6
22	27	8 ± 2	78.5 ± 19.6
24	32	14 ± 3	137.3 ± 29.4
30	36	18 ± 3	176.5 ± 29.4
33	41	20 ± 5	196.1 ± 49
36	46	25 ± 5	245.2 ± 49
42	55	30 ± 5	294.2 ± 49

COATING MATERIALS

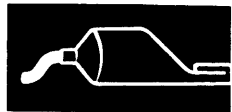

The recommended coating materials prescribed in Komatsu Shop Manuals are listed below.

Nomenclature	Komatsu code	Applications
Adhesives	LT-1A	Used to apply rubber pads, rubber gaskets, and cork plugs.
	LT-1B	Used to apply resin, rubber, metallic and non-metallic parts when a fast, strong seal is needed.
	LT-2*	Preventing bolts, nuts and plugs from loosening and leaking oil.
	LT-3	Provides an airtight, electrically insulating seal. Used for aluminum surfaces.
Liquid gasket	LG-1	Used with gaskets and packings to increase sealing effect.
	LG-3	Heat-resistant gasket for precombustion chambers and exhaust piping.
	LG-4	Used by itself on mounting surfaces on the final drive and transmission cases. (Thickness after tightening: 0.07 – 0.08 mm)
	LG-5	Used by itself to seal grease fittings, tapered screw fittings and tapered screw fittings in hydraulic circuits of less than 50 mm in diameter.
Antifriction compound (Lubricant including molybdenum disulfide)	LM-P	Applied to bearings and taper shafts to facilitate press-fitting and to prevent sticking, burning or rusting.
Grease (Lithium grease)	G2-LI	Applied to bearings, sliding parts and oil seals for lubrication, rust prevention and facilitation of assembling work.
Vaseline	—	Used for protecting battery electrode terminals from corrosion.

*LT-2 is also called LOCTITE in the shop manuals.

ELECTRIC WIRE CODE

In the wiring diagrams, various colors and symbols are employed to indicate the thickness of wires.

This wire code table will help you understand WIRING DIAGRAMS.

Example: 05WB indicates a cable having a nominal number 05 and white coating with black stripe.

CLASSIFICATION BY THICKNESS

Nominal number	Copper wire			Cable O.D. (mm)	Current rating (A)	Applicable circuit
	Number strands	Dia. of strands (mm)	Cross section (mm ²)			
01	11	0.32	0.88	2.4	12	Starting, lighting, signal etc.
02	26	0.32	2.09	3.1	20	Lighting, signal etc.
05	65	0.32	5.23	4.6	37	Charging and signal
15	84	0.45	13.36	7.0	59	Starting (Glow plug)
40	85	0.80	42.73	11.4	135	Starting
60	127	0.80	63.84	13.6	178	Starting
100	217	0.80	109.1	17.6	230	Starting

CLASSIFICATION BY COLOR AND CODE

Priority	Circuits		Starting	Charging	Lighting	Signal	Instrument	Other
	Classification							
1	Primary	Code	B	W	R	G	Y	L
		Color	Black	White	Red	Green	Yellow	Blue
2	Auxiliary	Code	BW	WR	RW	GW	YR	LW
		Color	Black & White	White & Red	Red & White	Green & White	Yellow & Red	Blue & White
3		Code	BY	WB	RB	GR	YB	LR
		Color	Black & Yellow	White & Black	Red & Black	Green & Red	Yellow & Black	Blue & Red
4		Code	BR	WL	RY	GY	YG	LY
		Color	Black & Red	White & Blue	Red & Yellow	Green & Yellow	Yellow & Green	Blue & Yellow
5		Code	—	WY	RG	GB	YL	LB
		Color	—	White & Yellow	Red & Green	Green & Black	Yellow & Blue	Blue & Black
6		Code	—	WG	RL	GL	YW	
		Color	—	White & Green	Red & Blue	Green & Blue	Yellow & White	

WEIGHT TABLE



This weight table is a guide for use when transporting or handling components.

(Unit: kg)

Machine model	WA70-1	
	Serial numbers	
	10001 – 11999	12001 and up
Engine assembly	287	287
Radiator	22	14
Fuel tank (empty)	37	37
Torque converter assembly	33	33
Transmission (with torque converter)	291	291
Front drive shaft	7	7
Center drive shaft	6	6
Rear drive shaft	3	3
Front axle assembly (dry)	226	218
Rear axle assembly (dry)	223	219
Axle support	22	42
Wheel (1 piece)	33	33
Tire (17.5/65-20-10PR)	74	72
Steering valve	6	6
Steering cylinder	7	7
Engine hood	14	18
Front support	62	92
Operator seat assembly	25	25
Canopy	44	44
Counterweight	551	620
Front frame (without accessory)	361	346
Rear frame (without accessory)	427	350
Hydraulic tank (dry)	36	30
Hydraulic pump	10	10
Main control valve	8	9
Lift cylinder assembly (1 piece)	29	28
Dump cylinder assembly (1 piece)	23	22
Bucket link	9	9
Bellcrank	54	61
Lift arm (with bushing)	254	254
Bucket	289 (with teeth)	321 (with bolt on cutting edge)

LIST OF LUBRICANT AND WATER

RESERVOIR	KIND OF FLUID	AMBIENT TEMPERATURE									CAPACITY (ℓ)	
		-22 -30	-4 -20	14 -10	32 0	50 10	68 20	86 30	104 40	122°F 50°C	Specified	Refill
Engine oil pan	Engine oil									SAE 30	8	7
										SAE 10W		
										SAE 10W-30		
										SAE 15W-40		
Brake	Engine oil									SAE 10W	1	1
										SAE 5W		
Transmission case										SAE 10W	21	12
Hydraulic system										SAE 10W	32.5	19
Axle (Front and rear)		See NOTE (4)									each 8	each 8
Fuel tank	Diesel fuel		*								10001 - 60 11999	-
										ASTM D975 No. 2	12001 - 63	
Cooling system	Water	Add antifreeze									10001 - 14 11999 12001 - 12	-

* ASTM D975 No. 1

NOTE:

(1) When fuel sulphur content is less than 0.5%, change oil in the oil pan every periodic maintenance hours described in this manual. Change oil according to the following table if fuel sulphur content is above 0.5%.

Fuel sulphur content	Change interval of oil in engine oil pan
0.5 to 1.0%	1/2 of regular interval
Above 1.0%	1/4 of regular interval

(2) When starting the engine in an atmospheric temperature of lower than 0°C, be sure to use engine oil of SAE10W, SAE10W-30 and SAE15W-40, even though an atmospheric temperature goes up to 10°C more or less in the day time.

(3) Use API classification CD as engine oil and if API classification CC, reduce the engine oil change interval to half.

(4) For axle oil, use only recommended oil as follows.
 SHELL: DONAX TT or TD
 CALTEX: RPM TRACTOR HYDRAULIC FLUID
 CHEVRON: TRACTOR HYDRAULIC FLUID
 TEXACO: TDH OIL
 MOBIL: MOBILAND SUPER UNIVERSAL

★ It is possible to substitute engine oil CLASS-CD SAE30 for axle oil.

ASTM: American Society of Testing and Material
 SAE: Society of Automotive Engineers

Specified capacity: Total amount of oil including oil for components and oil in piping.
 Refill capacity: Amount of oil needed to refill system during normal inspection and maintenance.

ENGINE

12 TESTING AND ADJUSTING



Standard value table	12- 2
Tool list for testing and adjusting	12- 3
Adjusting valve clearance	12- 4
Measuring compression pressure	12- 5
Testing and adjusting fuel injection timing ...	12- 6
Adjusting fuel injection timing	12- 7
Testing and adjusting fan belt tension	12- 8
Adjusting of fuel cut solenoid	12- 9
Measuring operating force and operating angle of accelerator pedal	12-10

★ The following precautions are necessary when using the Standard Value Tables to make judgements during troubleshooting or during testing and adjusting.





1. The values in these tables are based on the values for new machines leaving the plant, so they should be used as target values when repairing or when estimating wear after a period of use.
2. The standard values in these tables for judgement when troubleshooting are estimated values based on the standard values for the machine when shipped from the plant, and on the results of various tests. Therefore, they should be used as reference in combination with repair and operating records when making judgements.
3. These standard value tables must not be used for standard values when judging claims. In addition, do not use these values alone to make simple judgements.

STANDARD VALUE TABLE

Engine				Komatsu 4D95L-W			
Category	Item	Condition	Unit	Standard value	Permissible value		
Performance	Engine speed	High idling speed	rpm	2320-2420	-		
		Low idling speed	rpm	750-850	-		
	Necessary starting speed	0°C -20°C (using starting aid)	rpm rpm	Min. 150 Min. 100	- -		
Intake and exhaust system	Intake resistance	All speed	mmH ₂ O	Max. 300	-		
	Exhaust temperature	All speed (intake air temp.:20°C)	°C	Max. 650	Max. 650		
	Exhaust gas color	Quick acceleration	Bosch index	Max. 4.0	5.0		
		At high idling	Bosch index	Max. 3.0	3.5		
Valve clearance (When engine is cold)	Intake valve	mm	0.35	-			
	Exhaust valve	mm	0.50	-			
Body	Compression pressure	Oil temperature 40 - 60°C (engine speed: 320-360 rpm)	kg/cm ²	Min. 30	Min. 20		
	Blow-by pressure	At high idling, oil temperature min. 60°C	mmH ₂ O	Max. 50	100		
Lubrication system	Oil pressure (SAE30, min. 80°C)	At high idling	kg/cm ²	3.5-6.0	Min. 2.1		
		At low idling	kg/cm ²	Min. 1.0	0.7		
	Oil temperature	Whole speed range (inside oil pan)	°C	80-110	120		
	Oil consumption ration	At continuous rated horsepower (proportion of fuel consumption)	%	Max. 0.5	Max. 1.0		
Fuel system	Fuel injection pressure	Nozzle tester	kg/cm ²	120±10	96		
	Fuel injection timing	Before top dead center	Degree	14±1	14±1		
Cooling system	Coolant temperature	Whole speed range (at engine outlet)	°C	-	-		
	Radiator pressure valve	Opening pressure (Differential pressure)	kg/cm ²	0.9±0.15	0.9±0.15		
	Fan speed	At rated engine speed	rpm	2360-2480	2360-2480		
	Fan belt tension (Alternator-Fan pulley)	Deflection when pushing with finger force approx. 6 kg	mm	8	8		
Accelerator pedal	Operating force	Serial No. 10001-11999	kg	7-10.5	Max. 15		
	Operating angle	α_1		Degree	45	-	
		α_2		Degree	12-16	-	
	Stopper height L	mm		19	-		
	Rod length	X_1		mm	93-99	-	
X_2		mm		1202	1294		
				Serial No. 10001-11999	Serial No. 12001 and up	Serial No. 10001-11999	Serial No. 12001 and up

TOOL LIST FOR TESTING AND ADJUSTING

No.	Testing and measuring item	Tool	Part No.	Remarks
1	Engine speed	Tachometer	799-203-8000	Digital display 60 – 19,999 rpm
2	Battery specific gravity	Battery coolant tester	795-500-1000	1.100 – 1.300
3	Coolant freezing temperature			– 5 – – 50°C
4	Water temperature, oil temperature, intake temperature	Thermistor temperature gauge	790-500-1300 or 799-101-6000	0 – 200°C
5	Exhaust temperature			0 – 1,000°C
6	Lubricating oil pressure	Engine pressure measuring kit	799-203-2002	0 – 10 kg/cm ²
7	Fuel pressure			0 – 20 kg/cm ²
8	Intake pressure, exhaust pressure			0 – 1,500 mmHg
9	Blow-by pressure			0 – 1,000 mmH ₂ O
10	Intake resistance			– 1,000 – 0 mmH ₂ O
11	Compression pressure	Compression gauge Adapter No.	795-502-1204 795-502-1380	0 – 70 kg/cm ²
12	Blow-by pressure	Blow-by checker	799-201-1503	0 – 500 mmH ₂ O
13	Valve clearance	Feeler gauge	795-125-1370	0.35, 0.50 mm
14	Exhaust gas color	Smoke meter	Commercially available	Discoloration 0 to 70% standard color (Discoloration % x 1/10 = Bosch index)
15	Fuel or water mixed in oil	Engine oil checker	799-201-6000	Water content 0.1%, 0.2% in standard sample
16	Coolant quality	Water quality tester	799-202-7001	PH, nitrous acid ion concentration
17	Leakage from cooling system	Cap tester	799-202-9001	0 – 2 kg/cm ²
18	Fuel injection pressure Nozzle injection condition	Nozzle tester	Commercially available	0 – 300 kg/cm ²
19	Electrical circuit	Tester	Commercially available	Current, voltage, resistance
20	Accelerator pedal force	Push-pull scale	7A0-262-0020	0 – 25 kg

-  When carrying out testing, adjusting or troubleshooting, stop the machine on level ground, install the safety bar on the frame, lower the bucket to the ground, and stop the engine. Then apply the parking brake and block the tires.
-  When working in groups, use agreed signals and do not allow unauthorized persons near the machine.
-  When checking the water level in the radiator wait for the water to cool. Do not remove the radiator cap while the water is hot. Boiling water may spurt out.
-  Be careful not to get caught in rotating parts.

ADJUSTING VALVE CLEARANCE

- ★ Measurement condition: Engine is cold.
- ★ Adjust clearance between valve and rocker lever as follows.

Unit: mm

	Intake valve	Exhaust valve
Cold	0.35	0.50

Special tool

	Part number	Part name	Q'ty
A	795-125-1370	Feeler gauge	1

1. Remove cylinder head cover (1).
2. Rotate the crankshaft in the normal direction to align pointer (3) with the 1.4 TOP mark on crankshaft pulley (2). When rotating, check the movement of the valves. When the pointer is in line with the 1.4 TOP mark, No.1 cylinder should be at compression top dead center.
3. When No. 1 cylinder is at compression top dead center, adjust the valve marked ●. When No. 4 cylinder is at compression top dead center, adjust the valves marked ○.

Cylinder.No.	1	2	3	4
Intake valve	●	○	●	○
Exhaust valve	●	●	○	○

4. To adjust, insert tool A between rocker lever (4) and valve stem (5) and turn adjustment screw (6) until clearance is a sliding fit. Then tighten lock nut (7) to hold adjustment screw in position.

 Lock nut: 1.35 ± 0.15 kgm

5. Next, rotate crankshaft one turn in the normal direction and adjust the valve clearance of the remaining valves marked ○.

- ★ After adjusting No.1 cylinder at compression top dead center, it is also possible to turn the crankshaft 180° each time and adjust the valve clearance of each cylinder according to the firing order.

- Firing order: 1-2-4-3

- ★ After tightening the lock nut, check the clearance again.

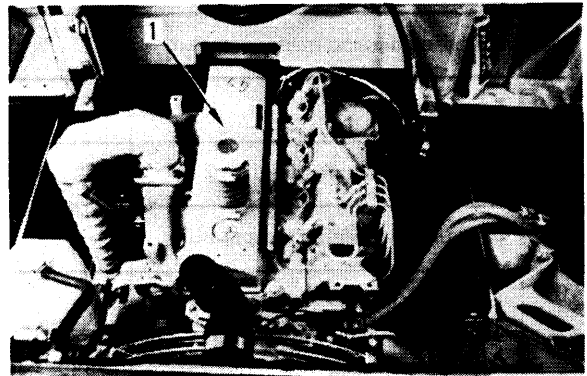

415P002

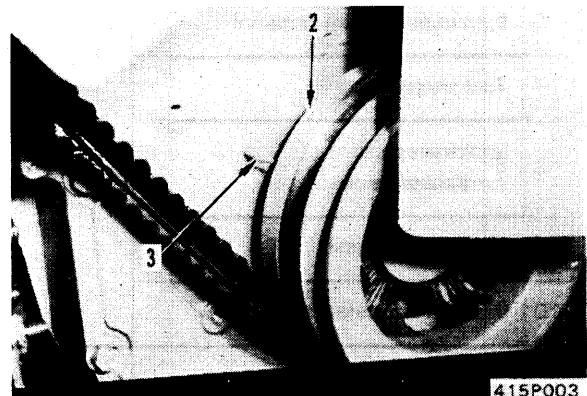

415P003

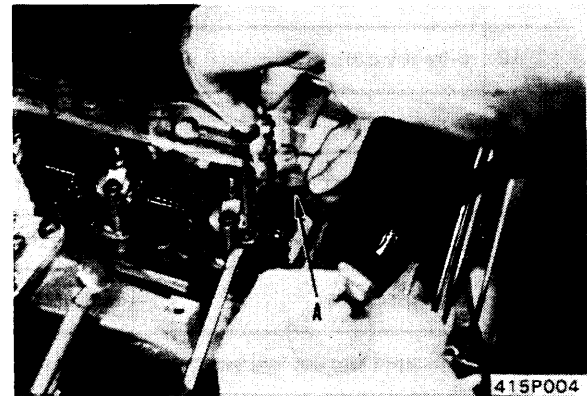

415P004

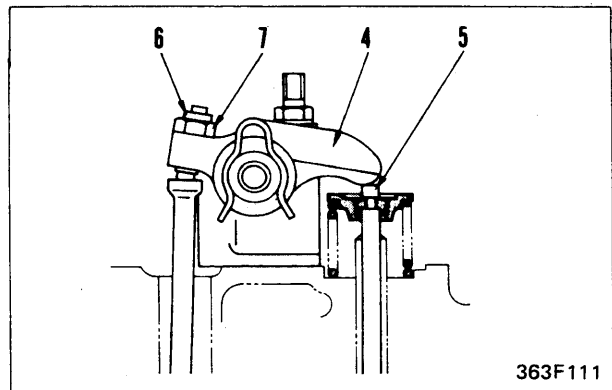

363F111

MEASURING COMPRESSION PRESSURE

- ★ Measurement condition
 - Oil temperature: 40 – 60°C
 - Engine valve clearance: Standard value.
 - Engine speed: 320 – 360 rpm

Unit: kg/cm²

Item	Standard value	Permissible value
Compression pressure	Min. 30	20

Special tools

	Part number	Part name	Q'ty
A	795-502-1204	Compression gauge	1
A ₁	795-502-1380	· Adapter	1
B	799-203-8000	Tachometer	1

- ★ If performance tests or troubleshooting shows that the piston, piston ring or cylinder liner may be worn, measure the compression pressure.

⚠ When measuring the compression pressure, be careful not to touch the exhaust manifold or muffler, or to get caught in rotating parts.

1. Adjust valve clearance.
 - ★ For details, see ADJUSTING VALVE CLEARANCE.
 2. Warm up engine (oil temperature 40 – 60°C).
 3. Remove nozzle holder assembly.
 4. Install adapter A₁ in mount of nozzle holder assembly, and connect pressure gauge A.
 5. Set engine tachometer B in position.
 6. Disconnect fuel cut solenoid connector.
 - Crank engine with starting motor and measure compression pressure.
 - ★ Measure the compression pressure at the point where the pressure gauge indicator remains steady.
 - ★ When measuring the compression pressure, measure the engine speed to confirm that it is within the specified range.
- ★ Installing the nozzle holder assembly after measuring the compression pressure.

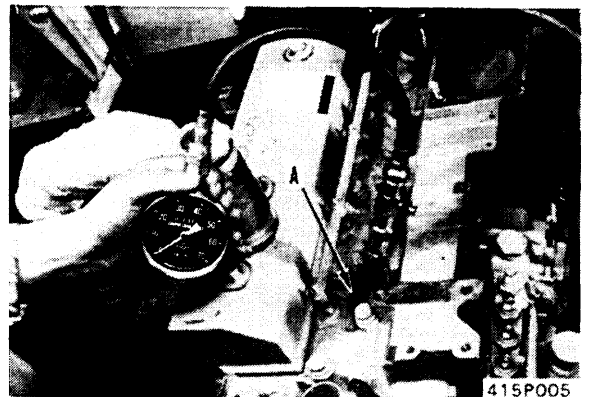

TESTING AND ADJUSTING FUEL INJECTION TIMING

★ Measurement condition

- Coolant temperature: Inside operating range.

Item	Standard value	Unit: degree
		Permissible value
Fuel injection timing	B.T.D.C. 14	14 ± 1

TESTING FUEL INJECTION TIMING

1. Disconnect fuel injection pipe (1) of No. 1 cylinder.
2. Remove delivery valve holder (2), then remove delivery valve (3) and spring (4), and install delivery valve holder (2) again.
3. Place fuel accelerator pedal at FULL position.
4. Operate priming pump and rotate crankshaft slowly in normal direction. Check point where fuel stops flowing from delivery valve holder (2).
5. Check that 14° I.J. line on crankshaft pulley (6) and pointer (7) are aligned at point where fuel stops flowing.

 Delivery valve holder: 3.3 ± 0.2 kgm

★ BEYOND injection timing line:

Timing RETARDED

★ BEFORE injection timing line:

Timing ADVANCED

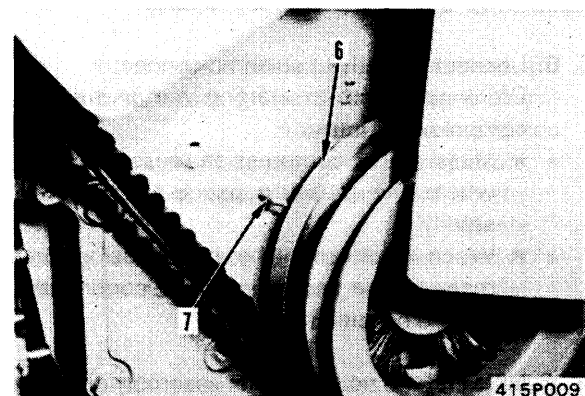
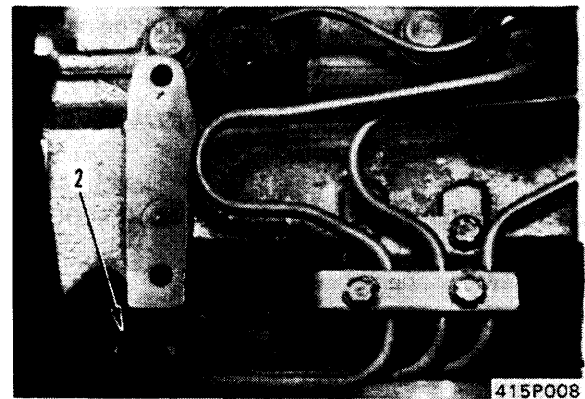
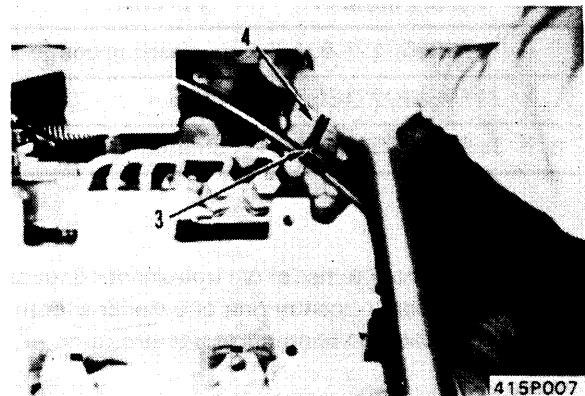
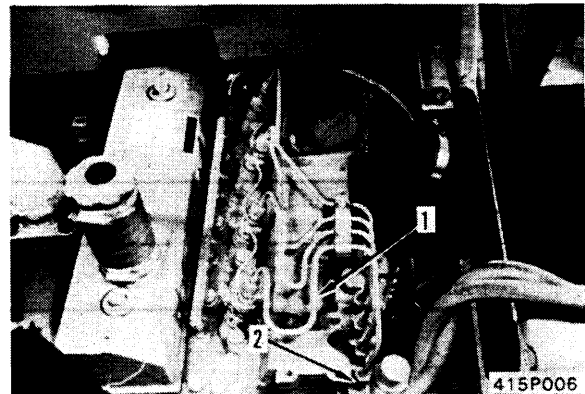

ADJUSTING FUEL INJECTION TIMING

1. Rotate crankshaft from top dead center to 30 – 40° in opposite direction.
2. Rotate crankshaft in normal direction, then align 14° I.J. line on crank pulley and pointer accurately.
3. Remove nuts (8) of fuel injection pump mounting flange and nut (9) of fuel injection pump support bracket.
4. Move fuel injection pump to outwards. Operating priming pump, move fuel injection pump to cylinder block end. Stop fuel injection pump at point where fuel stops flowing from delivery valve holder.
5. Tighten nuts (8) of fuel injection pump mounting flange and nut (9) of fuel injection pump support bracket.
 - ★ Check again that fuel injection timing is adjusted correctly.
6. Remove delivery valve holder (2), and install delivery valve (3) and spring (4), then install delivery valve holder (2).

 Delivery valve holder: **3.3 ± 0.2 kgm**

7. Connect fuel injection pipe (1).

 Sleeve nut: **2.4 ± 0.1 kgm**

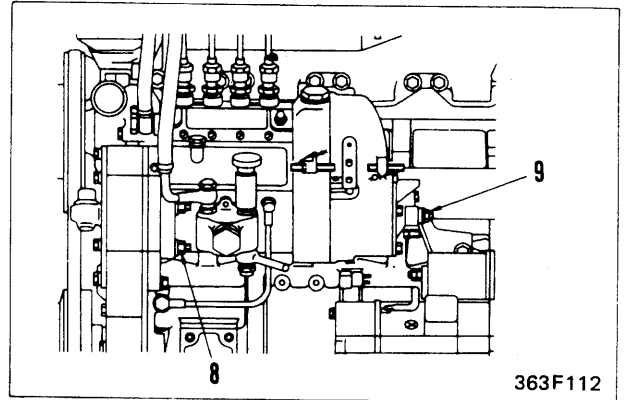

TESTING AND ADJUSTING FAN BELT TENSION

1. Measuring procedure

- 1) Push the V-belt with a force of approx. 6 kg, at a point midway between the fan pulley and the alternator pulley.
- 2) Use a scale to measure the amount the V-belt deflection.

Unit: mm

Item	Standard value	Permissible value
Deflection of belt	8	8

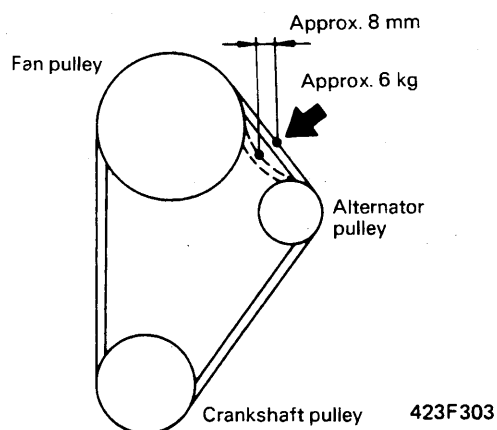

2. Adjustment procedure

- 1) Loosen mounting bolt (1) of the alternator assembly, and the mounting bolt (2) of adjustment plate.
- 2) Insert a stick or bar between the alternator mounting bolt and the cylinder block, then raise the alternator to the outside.
- 3) Adjust the belt (3) tension and temporarily tighten mounting bolt (3).
- 4) Check that the belt tension is correct then tighten all mounting bolts fully.

