

SHOP MANUAL

KOMATSU

W120-3

MACHINE MODEL	SERIAL No.
W120-3	50001 and up

The affected pages are indicated by the use of the following marks. It is requested that necessary actions be taken to these pages according to the table below.

Mark	Indication	Action required
○	Pages to be newly added	Add
●	Page to be replaced	Replace
()	Page to be deleted	Discard

Pages having no marks are not revised.

LIST OF REVISED PAGES

Mark	Page	Revision number	Mark	Page	Revision number	Mark	Page	Revision number	Mark	Page	Revision number	Mark	Page	Revision number
●	00- 1	①		21- 9		○	23- 4	①	○	23-46	①	○	23-86	①
○	00- 2	①		21-10		○	23- 5	①	○	23-47	①	○	23-87	①
○	00- 2-1	①		21-11		○	23- 6	①	○	23-48	①	○	23-88	①
●	00- 3	①		21-12		○	23- 7	①	○	23-49	①	○	23-89	①
	00- 4			21-13		○	23- 8	①	○	23-50	①	○	23-90	①
	00- 5			21-14		○	23- 9	①	○	23-51	①	○	23-91	①
	00- 6			21-16		○	23-10	①	○	23-52	①	○	23-92	①
	00- 7			21-17		○	23-11	①	○	23-53	①	○	23-94	①
	00- 8			21-18		○	23-12	①	○	23-54	①	○	23-95	①
	00- 9			21-19		○	23-13	①	○	23-55	①	○	23-96	①
	00-10			21-20		○	23-14	①	○	23-56	①	○	23-97	①
	01- 1			21-21		○	23-15	①	○	23-57	①	○	23-98	①
	01- 3			21-22		○	23-16	①	○	23-58	①	○	23-99	①
	01- 4			21-23		○	23-17	①	○	23-59	①	○	23-100	①
	01- 5			21-24		○	23-18	①	○	23-60	①	○	23-102	①
●	01- 6	①		21-25		○	23-19	①	○	23-61	①	○	23-103	①
●	01- 7	①		21-26		○	23-20	①	○	23-62	①	○	23-104	①
●	01- 8	①		21-27		○	23-21	①	○	23-63	①	○	23-105	①
	01- 9			21-28		○	23-22	①	○	23-64	①	○	23-106	①
	01-10			21-29		○	23-23	①	○	23-65	①	○	23-107	①
	01-11			21-30		○	23-24	①	○	23-66	①	○	23-108	①
	01-12			21-31		○	23-25	①	○	23-67	①		24- 1	
	01-13			21-32		○	23-26	①	○	23-68	①		24- 3	
	01-14			21-33		○	23-27	①	○	23-69	①		24- 4	
	01-15			21-34		○	23-28	①	○	23-70	①		24- 5	
	01-16			21-35		○	23-30	①	○	23-71	①		24- 6	
	01-17			21-36		○	23-31	①	○	23-72	①		24- 8	
	01-18			21-37		○	23-32	①	○	23-73	①		24- 9	
	01-19			21-38		○	23-33	①	○	23-74	①		24-10	
	01-20			21-39		○	23-34	①	○	23-75	①		24-11	
	01-21		○	22- 1	①	○	23-35	①	○	23-76	①		24-12	
	01-22		○	22- 3	①	○	23-36	①	○	23-77	①		24-13	
	21- 1		○	22- 4	①	○	23-37	①	○	23-78	①		41- 1	
	21- 3		○	22- 5	①	○	23-38	①	○	23-79	①		41- 3	
	21- 4		○	22- 6	①	○	23-39	①	○	23-80	①		41- 6	
	21- 5		○	22- 7	①	○	23-40	①	○	23-81	①		42- 1	
	21- 6		○	22- 8	①	○	23-41	①	○	23-82	①		42- 3	
	21- 7		○	23- 1	①	○	23-42	①	○	23-83	①		42- 4	
	21- 8		○	23- 3	①	○	23-44	①	○	23-84	①		42- 5	
						○	23-45	①	○	23-85	①		42- 6	

Mark	Page	Revision number	Mark	Page	Revision number	Mark	Page	Revision number	Mark	Page	Revision number	Mark	Page	Revision number
○	42- 7	①	○	53-19	①	○	63- 8	①	○	72- 3	①			
○	43- 1	①	○	53-20	①	○	63- 9	①	○	72- 4	①			
○	43- 3	①	○	53-21	①	○	63-10	①	○	73- 1	①			
○	43- 4	①	○	53-22	①	○	63-11	①	○	73- 3	①			
○	43- 5	①	○	53-23	①	○	63-12	①	○	73- 4	①			
○	43- 6	①		54- 1		○	63-13	①	○	73- 5	①			
○	43- 7	①		54- 3		○	63-14	①	○	73- 6	①			
○	43- 8	①		54- 4		○	63-15	①	○	73- 7	①			
	44- 1			54- 5		○	63-16	①	○	73- 8	①			
	44- 3			54- 6		○	63-18	①	○	73- 9	①			
	44- 4			61- 1		○	63-19	①	○	73-10	①			
	51- 1			61- 3		○	63-20	①	○	73-11	①			
	51- 3			61- 4		○	63-21	①	○	73-12	①			
	51- 4			61- 5		○	63-22	①	○	73-13	①			
	51- 5			61- 7		○	63-23	①	○	73-14	①			
	51- 6		○	61- 7-2	①	○	63-24	①	○	73-15	①			
	51- 7			61- 9		○	63-25	①	○	73-16	①			
	51- 8			61-10		○	63-26	①	○	73-18	①			
	51- 9			61-11		○	63-27	①	○	73-19	①			
	51-10			61-12		○	63-28	①		74- 1				
	51-11			61-13		○	63-29	①		74- 3				
	51-12			61-14		○	63-30	①		74- 4				
	51-13			61-15		○	63-31	①		74- 5				
	51-14			61-16		○	63-32	①		74- 6				
	51-15			61-17		○	63-33	①		74- 7				
	51-16		○	61-17-1	①	○	63-34	①		91- 1				
	51-17			61-18		○	63-35	①		91- 3				
	51-18			61-19		○	63-36	①		91- 5				
○	52- 1	①		61-20		○	63-38	①		91- 6				
○	52- 3	①		61-21		○	63-39	①		91- 7				
○	52- 4	①		61-22		○	63-40	①						
○	52- 5	①		61-23		○	63-41	①						
○	52- 6	①		61-24		○	63-42	①						
○	52- 7	①		61-25		○	63-43	①						
○	52- 8	①		61-26		○	63-44	①						
○	52- 9	①		61-27			64- 1							
○	53- 1	①		61-28			64- 3							
○	53- 3	①		61-29			64- 4							
○	53- 4	①		61-30			64- 5							
○	53- 5	①	○	62- 1	①	○	64- 5-1	①						
○	53- 6	①	○	62- 3	①	○	64- 5-2	①						
○	53- 7	①	○	62- 4	①		63- 6							
○	53- 8	①	○	62- 5	①		64- 7							
○	53- 9	①	○	62- 6	①		64- 8							
○	53-10	①	○	62- 7	①		64- 9							
○	53-12	①	○	62- 8	①		71- 1							
○	53-13	①	○	62- 9	①		71- 3							
○	53-14	①	○	63- 1	①		71- 4							
○	53-15	①	○	63- 3	①		71- 5							
○	53-16	①	○	63- 4	①		71- 6							
○	53-17	①	○	63- 5	①		71- 7							
○	53-18	①	○	63- 6	①	○	72- 1	①						

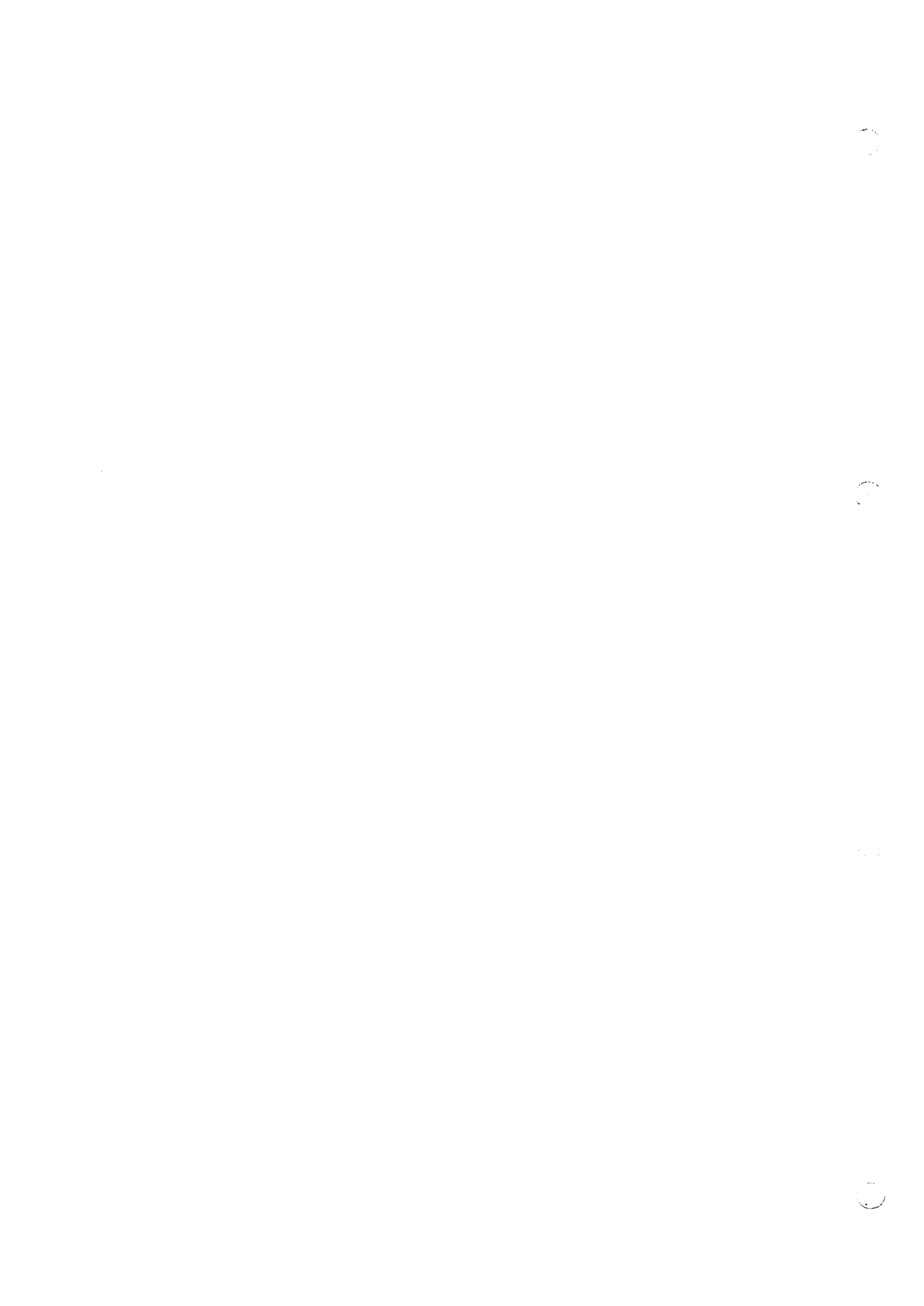



CONTENTS

	No. of page
GENERAL	01-1
 POWER TRAIN	
21 STRUCTURE AND FUNCTION	21-1
22 TESTING AND ADJUSTING	22-1
23 DISASSEMBLY AND ASSEMBLY	23-1
24 MAINTENANCE STANDARD	24-1
 STEERING SYSTEM	
41 STRUCTURE AND FUNCTION	41-1
42 TESTING AND ADJUSTING	42-1
43 DISASSEMBLY AND ASSEMBLY	43-1
44 MAINTENANCE STANDARD	44-1
 AIR SYSTEM	
51 STRUCTURE AND FUNCTION	51-1
52 TESTING AND ADJUSTING	52-1
53 DISASSEMBLY AND ASSEMBLY	53-1
54 MAINTENANCE STANDARD	54-1
 HYDRAULIC SYSTEM	
61 STRUCURE AND FUNCTION	61-1
62 TESTING AND ADJUSTING	62-1
63 DISASSEMBLY AND ASSEMBLY	63-1
64 MAINTENANCE STANDARD	64-1
 WORK EQUIPMENT	
71 STRUCTURE AND FUNCTION	71-1
72 TESTING AND ADJUSTING	72-1
73 DISASSEMBLY AND ASSEMBLY	73-1
74 MAINTENANCE STANDARD	74-1
 OTHERS	
91 ELECTRICAL SYSTEM	91-1

IMPORTANT SAFETY NOTICE

Proper service and repair is extremely important for the safe operation of machine. The service and repair techniques recommended by Komatsu and described in this manual are both effective and safe methods of operation. Some of these operations require the use of tools specially designed by Komatsu for the purpose.

To prevent injury to workers, the symbols  and  are used to mark safety precautions in this manual. The cautions accompanying these symbols should always be followed carefully. If any dangerous situation arises or may possibly arise, first consider safety, and take the necessary actions to deal with the situation.

FOREWORD

This shop manual has been prepared as an aid in improving the quality of repairs by giving the serviceman an accurate understanding of the product and by showing him the correct way to perform repairs and make judgements. Make sure you understand the contents of this manual and use it to full effect at every available opportunity.

Organization

This shop manual mainly contains the necessary technical information for operations performed in a service workshop.

For ease of understanding, the manual is divided into chapters for each main group of components; these chapters are further divided into the following sections.

Structure and function

This section explains the structure and function of each component. It serves not only to give an understanding of the structure, but also serves as reference material for troubleshooting.

Testing and adjusting

This section explains checks to be made before and after performing repairs, as well as adjustments to be made at completion of the checks and repairs. Troubleshooting charts correlating "Diagnoses" to "Causes" are also included in this section.

Disassembly and assembly

This section explains the order to be followed when removing, installing, disassembling or assembling each component, as well as precautions to be taken for these operations.

Maintenance standards

This section gives the judgement standards when inspecting disassembled parts.

USING THE SHOP MANUAL

Volumes

Shop manuals are issued for carrying out repairs.

They are divided as follows:

Chassis volume: issued for every machine model

Engine volume: issued for each engine series

Electrical volume :

Fuel system volume : each issued as one volume to cover all models

Attachments volume: }

In addition, the following volumes are issued for high level rebuilding techniques to cover all models.

Engine volume

The following volumes are issued for inspection and tests after repairs:

Guidance for reusable parts volume

Bench test methods volume

These various volumes are designed to avoid duplicating the same information. Therefore to deal with all repairs for any model, it is necessary to have the shop manual for that model as well as the relevant engine volume, the fuel system volume and the electrical volume.







This shop manual is **chassis volume**.

Distribution and Updating

Recipients of shop manuals are recorded at the Komatsu Head Office. Any additions, amendments or other changes will be sent to all recipients without fail, so someone should be appointed to be in charge of manuals. In this way, pages can be added or removed immediately and the manuals kept up to date and easy to use.

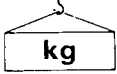
Symbols

So that the shop manual can be of sufficient practical use, we have marked important places for safety and quality with the following symbols.

SYMBOL	ITEM	REMARKS
	Safety	Special safety precautions are necessary when performing the work.
		Extra special safety precautions are necessary when performing the work because it is under internal pressure.
	Caution	Special technical precautions or other precautions for preserving standards are necessary when performing the work.
	Weight	Weight of parts or systems. Caution necessary when selecting hoisting wire, or when working posture is important, etc.
	Tightening torque	Places that require special care with the tightening torque when assembling.
	Coat	Places to be coated with adhesives, etc. when assembling.
	Oil, water	Places for filling with oil, etc. Oil capacity.
	Drain	Places for draining oil, etc. Quantity to be drained.

DEFINITION

Standard Size, Tolerance

The dimensions of finished parts each differ a little. Therefore, when determining the finished dimensions of parts, a dimension that will be standard is determined provisionally, and then the difference allowed from it is indicated. The former is called the **standard size**, and the latter the **tolerance**.

The way to show this is by a plus or a minus sign with the tolerance in smaller numerals to the right the standard size.

Example: $120_{-0.126}^{-0.022}$ (The same meaning as 119.874 – 119.978)

Moreover, when expressing the dimensions of a hole and the shaft that goes inside it, for the sake of convenience, the standard size for the hole and the shaft usually taken as the same, and the tolerances changed to indicate the tightness of the fit. For example, the fit of revolving shaft is indicated as follows, and is shown in the drawing.

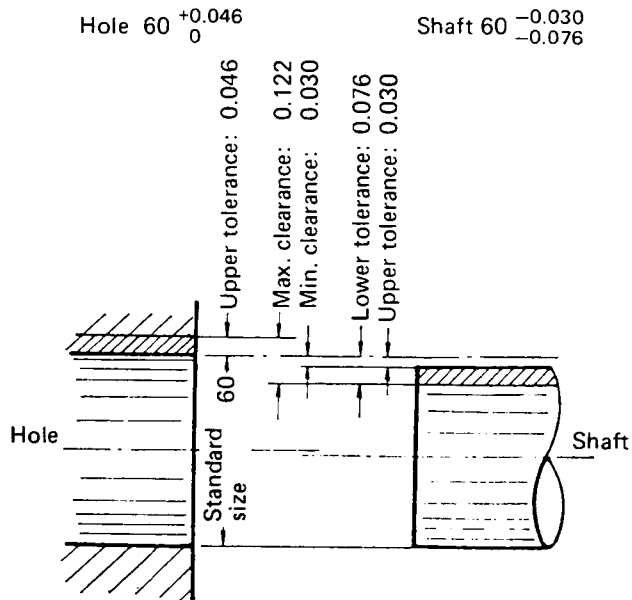

FOREWORD

Standard Size This is the standard value at the time of design, the finished dimension of new parts.

Repair Limit This is the limit in dimension up to which the part can be used. (The size of parts changes due to wear or distortion during use). When parts exceed the repair limit, they must be repaired or replaced as specified.

Standard Clearance This is the clearance between two new parts after assembly, shown as a range between minimum clearance and maximum clearance. In general, parts are adjusted to this clearance after repair.

Clearance Limit This is the maximum clearance allowed between parts. (The clearance increases due to wear, etc. during use.)
When the clearance exceeds the clearance limit, the parts must be repaired or replaced as specified.

Maintenance Standard This is the number given to items in diagrams of individual components. The same number is given in the left-hand column for ease of identification.

Unit: mm

No.	Check item	Criteria			Remedy
		Serial No.	Standard size	Repair limit	
1					

Unit: mm

No.	Check item	Criteria					Remedy	
		Serial No.	Standard size	Tolerance		Standard clearance		Clearance limit
				Shaft	Hole			
10								

SHOP MANUAL

W120-3

SERIAL NO. W120-3 50001 and up

01 GENERAL

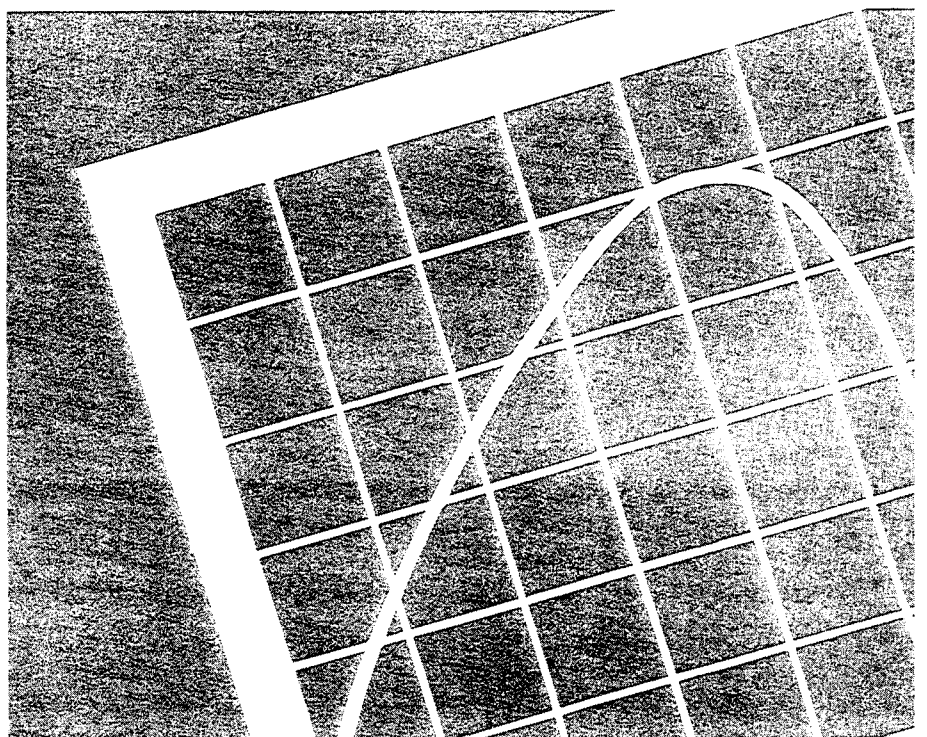



GENERAL

General view	01- 4
General assembly drawing	01- 5
Specifications	01- 6
Weight of component parts	01- 8
System capacity	01- 9
General inspection and test	01-10
General precaution for disassembly	01-12
General precaution for assembly	01-14
Standard tightening torque	01-20

GENERAL VIEW

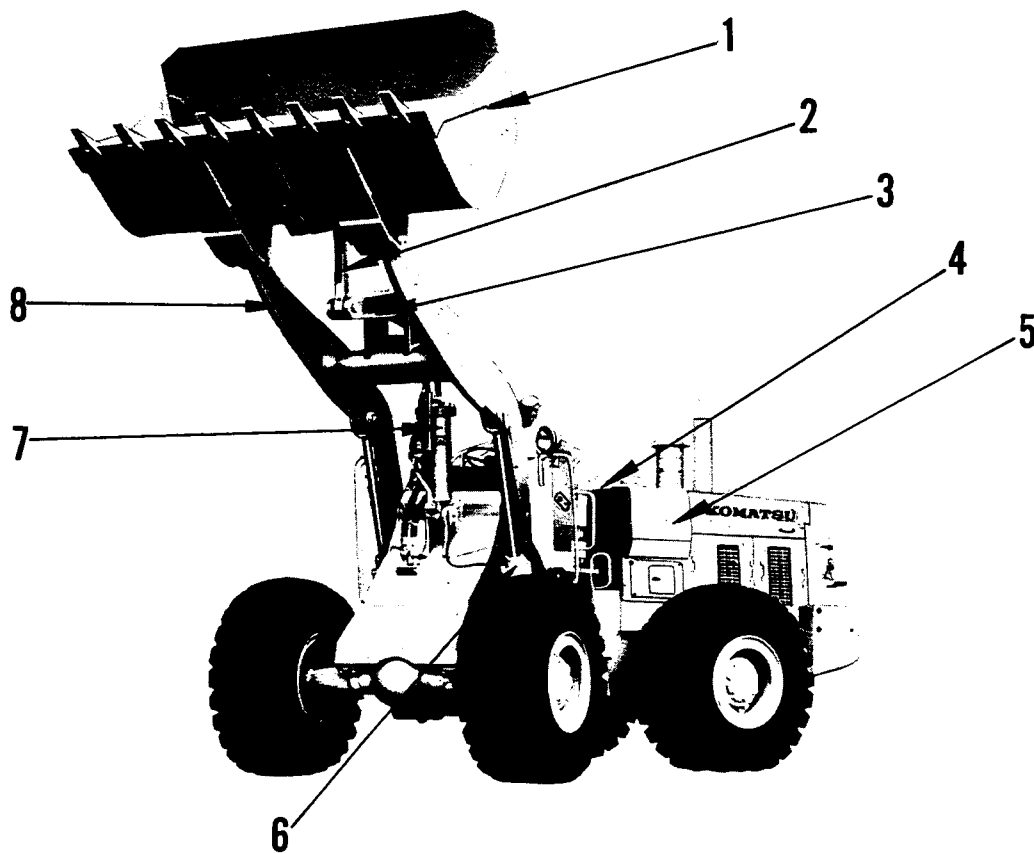

- 1. Bucket
- 2. Link
- 3. Crank lever
- 4. Hydraulic tank
- 5. Battery box
- 6. Boom cylinder
- 7. Bucket cylinder
- 8. Boom

GENERAL ASSEMBLY DRAWING

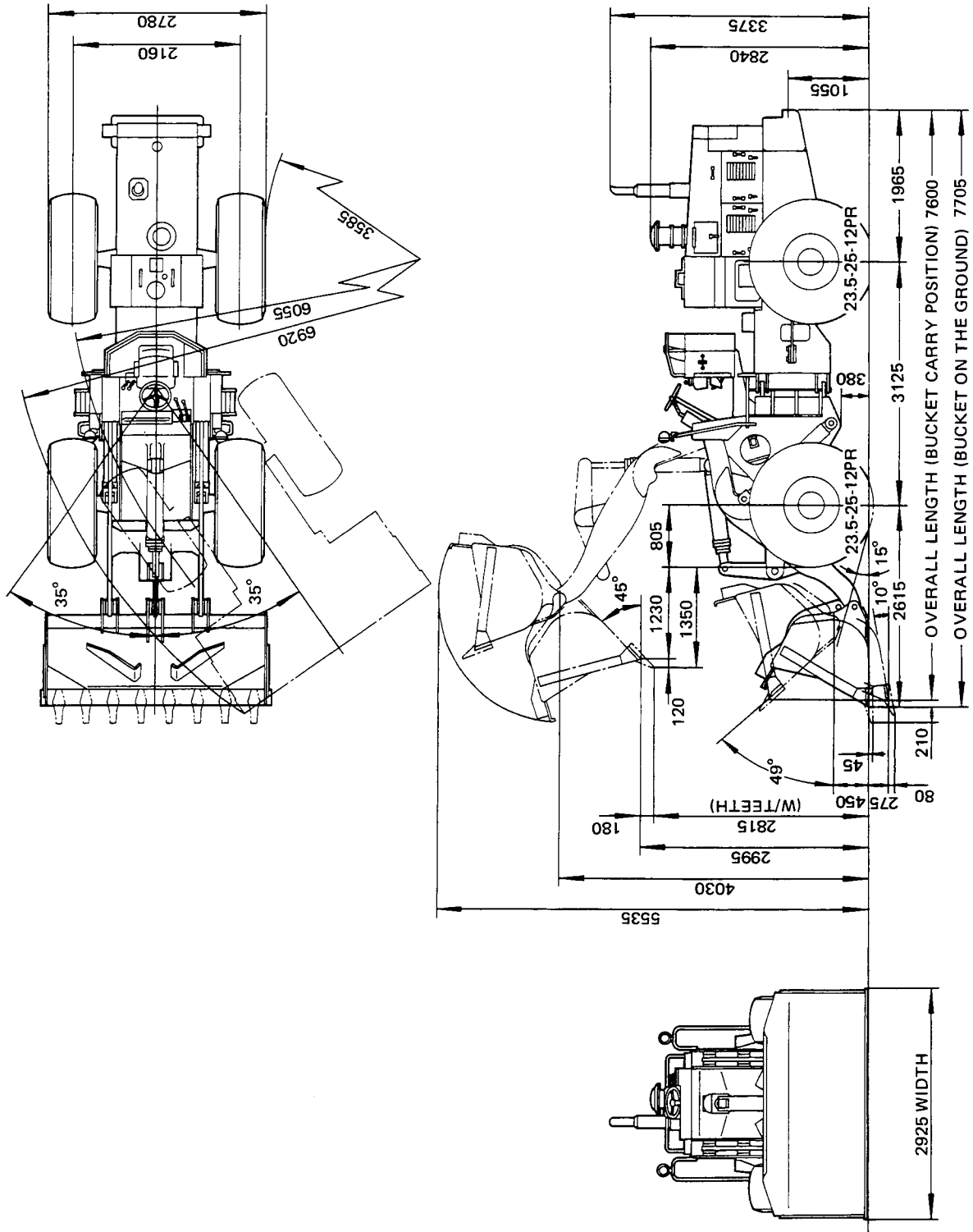

SPECIFICATIONS

Machine name and model		W120-3			
Serial numbers		50001 ~			
Weight	Operating weight	kg	17,140		
	Front wheel loading	kg	7,640		
	Rear wheel loading	kg	9,460		
Dimensions	Overall length (Tooth length excluded)	mm	7,705		
	Overall width	Overall width of machine	mm	2,780	
		Overall width of bucket	mm	2,925	
	Overall height	Top edge of canopy	mm	3,480	
		During bucket ascent	mm	5,535	
	Wheel base	mm	3,125		
	Tread	mm	2,160		
	Bucket hinge pin height	mm	4,030		
	Dumping clearance (bucket base)	mm	2,995		
	Dumping reach (bucket base)	mm	1,230		
	Bucket dump angle	°	45		
	Bucket tilt angle (traveling posture)	°	49		
	Excavation depth (10° dump)	mm	275		
	Minimum height above ground	mm	460		
	Performance	Bucket capacity	m ³	3.3	
Operating load		kg	5,400		
Bucket ascent time		sec	6.3		
Bucket descent time		sec	3.6		
Maximum traction force		kg	12,400		
Gradeability		°	25		
Minimum turning radius		At outside of machine	mm	6,920	
Travel speed		Forward	1st speed	km/h	0 ~ 7.1
			2nd speed	km/h	0 ~ 12.6
			3rd speed	km/h	0 ~ 30.0
	Reverse	1st speed	km/h	0 ~ 7.5	
		2nd speed	km/h	0 ~ 13.3	
		3rd speed	km/h	0 ~ 32.2	

Machine name and model		W120-3
Serial numbers		50001 ~
Engine	Name	Komatsu SA6D110
	Model	4-cycle direct injection, turbocharged diesel with aftercooler
	Number of cylinders – Bore x Stroke	6 – 110 mm x 125 mm
	Overall displacement	7,130 cc
	Rated output	200HP/2,500 rpm
	Maximum torque	69 kgm/1,800 rpm
	Fuel consumption	165 g/HP.h
	Starting motor	24V, 7.5kW
	Battery	24V(12Vx2) – 150Ah
Power train	Torque converter	Komatsu TCA34-1A, 3-element, single stage, single phase
	Transmission	Constant-mesh, full power shift
	Reduction unit	Hypoid gear
	Differential	Straight bevel gear
	Final drive	Planetary gear
Shaft and wheel	Drive system	Four wheel drive
	Front wheel shaft	Fixed frame, full floating
	Rear wheel shaft	Center pin support, full floating
	Tire	23.5–25–12PR
Brake	Foot brake	Air over hydraulic actuated on four wheels with separate axle-by-axle, dry single disc.
	Hand brake	Drum, air release, apply sping
Steering unit		Full hydraulic power, smooth steering at any engine speed
Hydraulic units	Work equipment pump discharge	330ℓ/min. / 2,500rpm
	Work equipment valve set pressure	193 kg/cm ²
	Steering valve set pressure	140 kg/cm ²
	Cylinder (Number– Bore x stroke)	Boom cylinder
Bucket cylinder		1 – 180 mm x 559 mm
Steering cylinder		2 – 100 mm x 432 mm

WEIGHT OF COMPONENT PARTS

GENERAL

WEIGHT OF COMPONENTS PARTS

 This weight table is a guide for use when transporting or handling components.

	Unit: kg
Engine ass'y (Komatsu S6D105)	550
Radiator ass'y (with grille support)	100
Torque converter ass'y	100
Transmission ass'y (with bracket)	380
Transmission control valve	25
Transmission 1st clutch pack ass'y	25
Transmission F & R clutch pack ass'y	35
Transmission 2nd & 3rd clutch pack ass'y	45
Front axle ass'y	700
Rear axle ass'y	700
Planetary carrier ass'y (1)	45
Front differential ass'y	90
Rear differential ass'y	110
Tire (with wheel, 20.5-25-12PR) (1)	330
Front frame (without accessory)	1100
Rear frame (without accessory)	900

	Unit: kg
Counter weight	1600
Bolster	150
Engine hood	110
Operator's compartment	130
Operator's seat	35
Bulkhead ass'y (with two batteries)	260
Hydraulic tank	170
Boom cylinder ass'y (1)	110
Bucket cylinder ass'y	120
Boom ass'y	920
Bucket lever	170
Bucket link	40
Bucket 2.3 m ³ (with teeth)	100
Fuel tank	210
Battery (Wet) (1)	45