

Operation & Maintenance Manual

WA90-5

WHEEL LOADER

SERIAL NUMBERS H50051 AND UP

DANGER

Incorrect operation and maintenance of this machine may be hazardous and cause injuries. The operator and maintenance personnel must read this manual before commencing operation or maintenance. Keep this manual within reach at all times and ensure that operating personnel read it at regular intervals.

NOTE

Komatsu has had the operating and maintenance instructions translated into all the languages of the European Union. Should you require a copy in another language please inquire at your local dealer's.

© 2006 Komatsu Hanomag GmbH

All Rights Reserved

Printed in Europe 11-06

KOMATSU

1. Introduction

1.1. Foreword

The machine must be operated, cleaned, and maintained very carefully to ensure safe and troublefree operation. If you operate the machine correctly, these operating instructions will help you to avoid injuries and damage to property. To ensure this, these operating instructions take into account all applicable legal regulations and directives; the operating instructions comprise the following information:

- Notes on the Operating Instructions
- Notes on Transport
- Notes on Safety Regulations
- Operating Instructions
- Troubleshooting
- Maintenance Instructions
- Technical Data
- Notes on Lubricants and Operating Agents

The operating manual belongs to the machine and is stored in the lid of the hinged console, on the left of the driver's cab.

The operating instructions are part of the machine and must always be available at hand in the machine.

If the operating instructions have been lost or if they have become unreadable, because they are dirty, you may receive a new copy from Komatsu or your local Komatsu dealer. If the machine is resold, the operating instructions, the EU Declaration of Conformity (CE), and the licence are to be handed over to the new owner.

The owner of the machine has to ensure that

- all persons driving the machine have the legally required minimum age and are physically and mentally fit to perform the tasks they are charged with.
- all persons in charge with operating or maintaining the machine are appropriately instructed before operation or maintenance is started. They must have completely read and understood these operating instructions. In particular, this applies to the following section "Notes on Safety Regulations" and the chapter "Safety".
- the machine is correctly operated.
- the machine is not improperly modified.



Please note:

If the owner modifies safety-related parts of the machine, the certificate of conformity of the manufacturer will lapse and the person who has performed the modification has to issue a new certificate. Should you have any questions concerning this point, please do not hesitate to ask Komatsu.

Our continuous effort to improve the machine's design may lead to changes of machine details. However, the introduction of these improvements does not oblige us to perform them on machines which have already been delivered and are already in use.

If these improvements result in minor changes, these minor changes will not be described in the operating instructions. Should you require new available information about your machine or have any questions concerning the information given in the operating instructions, please do not hesitate to contact either Komatsu or your responsible Komatsu dealer.

These operating instructions may refer to attachments and special equipment not available from your local Komatsu dealer. Should you require attachments or special equipment, ask your responsible Komatsu dealer.

EU Directives

This machine is labelled with the CE mark indicating that it meets all basic requirements concerning safety and protection of health of the EU Machinery Directive 89/392/EEC, its supplements 91/368 EEC and 93/44 EEC for Europe, and the regulation 95/27/EEC. In addition, the harmonised European standards EN 292-2 and EN 474/1 of 1994, and EN 474-3 of 1996 were applied for manufacture of the machine. This fact is documented in the EU Declaration of Conformity (CE) which is supplied together with the machine.

This means that in those cases in which the machine is modified in such a way that safety of the machine is affected, the person responsible for safety of the machine is the one who has arranged for the machine to be modified. If you use the machine for any other purpose than that defined as correct use, you are the person who has to ensure that safety is maintained. Modifications of the machine or use of the machine for any other purpose than that specified as correct use may require a new CE mark and thus new issuing of an EU Declaration of Conformity.

If a machine is used in other countries than Germany, it may be possible that special national safety devices and specifications are missing which may be required for the application in the relevant country. For example, for Komatsu machines, the manufacturer has to design the cab roof in such a way that a warning beacon can be attached to the roof. However, when driving the machine on roads, this warning beacon must be covered.

Should you have any questions concerning standards and guidelines in the respective country the machine is to be used in, please ask your Komatsu dealer before you start commissioning the machine.

In addition to the operating instructions, you must also adhere to all legal regulations on public traffic and all applicable regulations on prevention of accidents.

Notes on later installation of electrical and electronic devices and components

Electrical or electronic devices and/or components installed later emit electromagnetic radiation which may influence the proper function of electronic components and parts of the machine. This may impair safety of the machine and endanger persons. For this reason, strictly adhere to the following safety notes.

If you later install electrical and electronic devices and/or components in the machine and connect them to the vehicle electrical system, you are responsible for any malfunctions of the vehicle electronics or other components resulting from this installation. Above all, check that all electrical and electronic components which you install later comply with the valid version of the EMC directive 89/336/EEC and that they are labelled with the CE mark.

The following requirements must additionally be met for a later installation of mobile communication systems (e.g. radio, telephone):

- Only install devices which have a licence referring to valid national regulations.
- The device must be stationary.
- Only use portable or mobile devices in the cab, if they are connected to a stationary external aerial.
- Install the sender in such a way that it is physically separated from the vehicle electronics.
- When installing the aerial, make sure that it is installed correctly with a good chassis earth connection between the aerial and the chassis of the vehicle.

In addition, adhere to all information about installation and connection of cables and maximum power input indicated in the manufacturer's installation instructions of the machine.

1.2. Safety information

The procedures and precautionary measures concerning operation and maintenance only apply on the provision that the machine is used as intended.

Most accidents are caused by disregard of basic safety regulations during operation and maintenance of machines. In order to avoid accidents and thus damage to persons and property, read all applicable safety notes and warnings in these operating instructions and on the machine, before you start operation or maintenance of the machine and always adhere to these safety notes and warnings.

The following words are used in this manual and on stickers on the machine to signify safety instructions and enable them to be recognized as such at a glance:

DANGER

This word is used for safety messages and safety label where there is a probability of serious injury if the danger is not avoided. The safety instruction or sticker contains precautions which must be observed in order to avoid the danger. Failure to do so can also result in damage to the machine.

WARNING

This word is used for safety messages and safety label where there is a potentially dangerous situation which could lead to serious injury if the danger is not avoided. The safety instruction or sticker contains precautions which must be observed in order to avoid the danger. Failure to do so can also result in damage to the machine.

CAUTION

This word is used for safety messages and safety label in the event of danger which could result in minor or partly serious injuries if the danger is not avoided. It may also relate to dangers which may only result in damage to the machine.

NOTE

This word is used for precautions which have to be taken in order to avoid situations which could result in shortening the service life of the machine.

The safety instructions are listed in the chapter "2. Safety" on page 2-1 and following.

The transport of persons in the work equipment is strictly forbidden!

We cannot foresee all circumstances which could result in potential danger during maintenance and operation. The safety instructions in this manual and on the machine, therefore, do not necessarily contain all possible safety precautions. If you are using a procedure or measure not explicitly permitted and recommended in this manual, you must ensure that you and anyone else can use any such procedure without any danger or damage to the machine whatsoever. Please contact your local Komatsu dealer if you have any doubts about the safety of any procedures.

1.3. Introduction

1.3.1. Intended use

This loader is a machine with independent transmission, moving on wheels. Driving in forward direction, the loader can load or dig material using its attachments intended for loading operations (i.e. bucket).

The standard operation cycle of a loader includes filling up and loading of the bucket, transporting the material and emptying the bucket.

In combination with the forklift truck attachment the picking up, transporting and putting down of stacked material is also considered to be part of the machine's intended use.

If you use the machine for any other purpose than specified above, we will not accept any responsibility for safety. All considerations concerning safety will then be up to the owner or the operating and maintenance personnel. In any case, neither you nor any other person are/is authorised to perform work and functions explicitly prohibited in these operating instructions.

Refer to chapter "3.3.9. Working with the wheel loader" on page 3-58 for more details.

1.3.2. Breaking-in the machine

Before the shipment, each machine was carefully checked and adjusted. A machine that is to be newly commissioned has to be treated with utmost care during its first 100 operating hours.

If the machine is used for work involving loads exceeding the specified maximum load for the running-in period, its performance may be impaired prematurely and its service life may be shortened. A new machine must be run in and maintained very carefully and thoroughly.

The following points are particularly important:

- Idle the engine for 5 minutes after starting it up.
- Avoid operation with heavy loads or at high speeds.
- Avoid sudden starts, sudden acceleration, sudden steering and sudden stops except in cases of emergency.

The precautions given in this manual for operating, maintenance, and safety procedures are only those that apply when this product is used for the specified purpose. If the machine is used for a purpose that is not listed in this manual Komatsu cannot bear any responsibility for safety. All consideration of safety in such operations is the responsibility of the user.

Operations that are prohibited in this manual must never be carried out under any circumstances.

1.4. Location of plates

1.4.1. Machine identification plate

Position of the identification plate (1) (see enlargement)

Serial no. stamp marking (2)

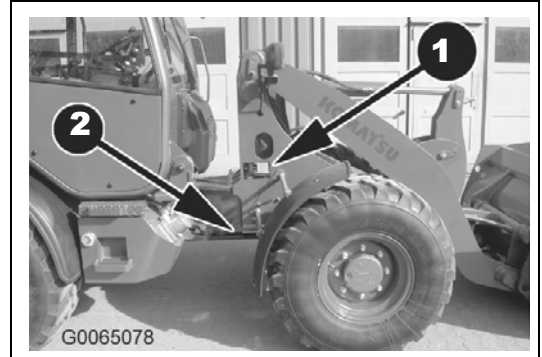

Machine identification plate (PIN)

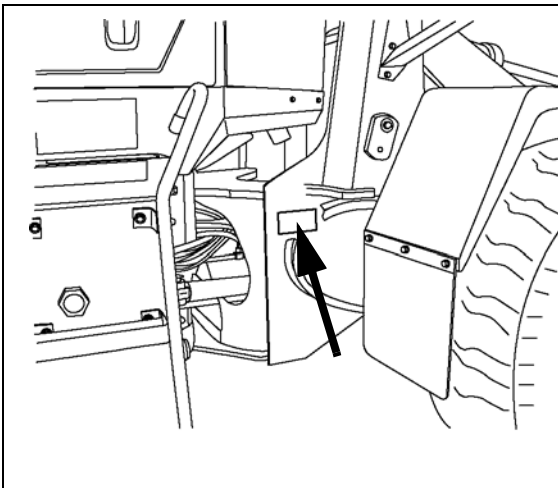

CE	MODEL	<input type="text"/>
	SERIAL NO.	<input type="text"/>
	MANUFACT. YEAR	<input type="text"/>
	MASS	<input type="text"/> kg
	ENGINE POWER	<input type="text"/> kW
Product Identification Number		<input type="text"/>
MANUFACTURER		Manufactured by KOMATSU HANDTAG GmbH for Komatsu Ltd., Tokyo, Japan
KOMATSU		424-93-H1210

GK020001GB

1.4.2. Engine name-plate

Engine name-plate with serial no.

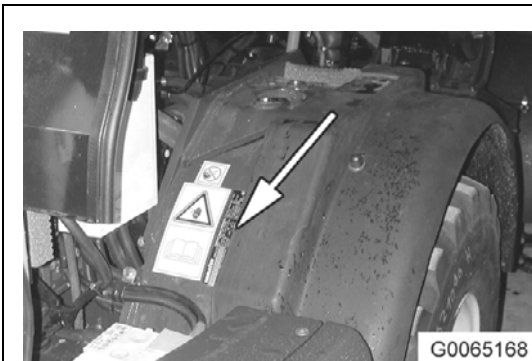

KOMATSU KOMATSU LTD.	Important Engine Information	Full title at Site: H7/W Xxxxxx
Model: XXXXXXXX ESN: XXXXXXXX	Engine Code: XXXX	PP3 Cert. Family: XXXXXXXXXXXX
Gross Rated HP/kW: XX/XX at XXXXrpm	Low Idle RPM: XXX rpm	Displacement: 3.26L/199in ³
Timing-BTDC: XX degrees	Valve Lash: Intake: 0.314mm/0.012in	Exhaust: 0.321mm/0.012in
Valve Lash: Intake: 0.314mm/0.012in	Exhaust: 0.321mm/0.012in	

G0065167

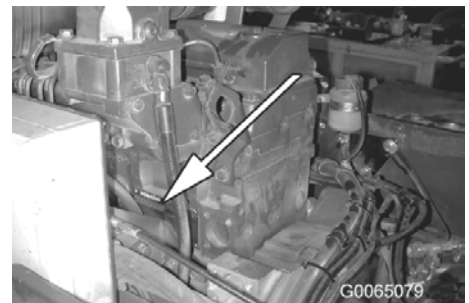

KOMATSU KOMATSU LTD.	Important Engine Information
Model: XXXXXXXX ESN: XXXXXXXX	Gross rated HP/kW: XX/XX at XXXXrpm
Low Idle RPM: XXX RPM	Engine Code: XXX
Displacement: 3.26L	Timing-BTDC: Xdegrees
Valve Lash: Intake: 0.35mm (solid shank) Exhaust: 0.50mm	EPA Cert. Family: XXXXXXXXXXXX
Fuel rate at rated HP/kW: XX.XXX/XXt	European Approval Number: XXXXXXXXXXXX
Date of Manufacture: XXXXXXXX	Made in Japan 6204-81-2421

G0065095.eps

1.4.3. Axle serial no. plate

This plate is located on the right of front axle and on the left of rear axle (1).

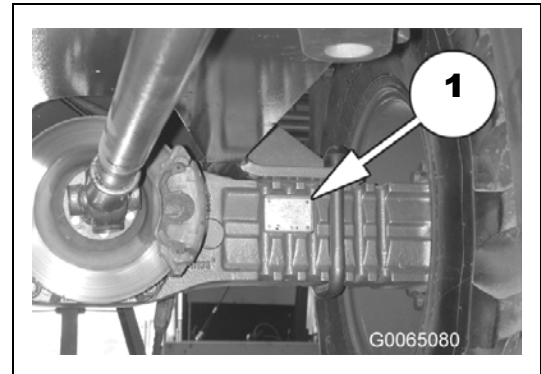

1.4.4. Transmission serial no. plate

This plate is located in travel direction front, above the transmission output (1).

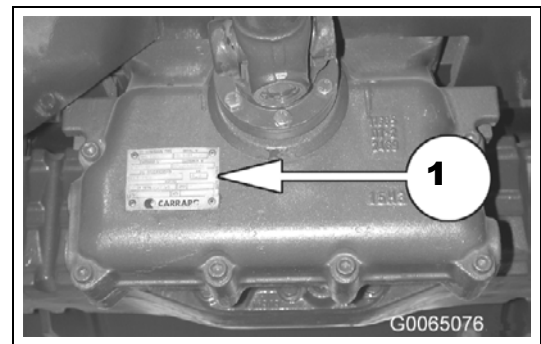

1.4.5. ROPS/FOPS-Cab serial no. plate

This plate is located on the right inside cab on the rear beam (1).

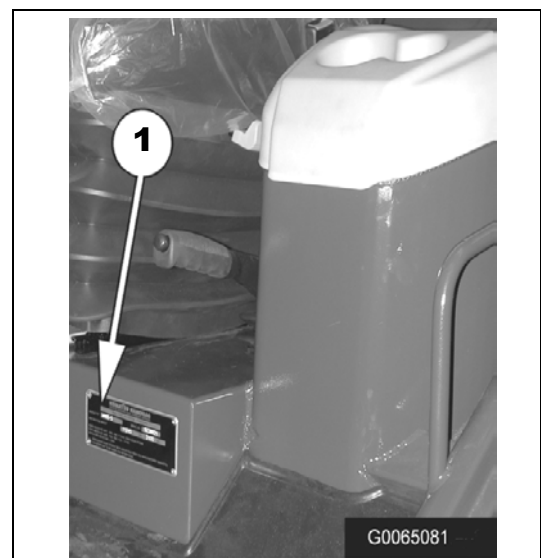

1.4.6. Operator's seat serial no. plate

This plate is located in front of seat, covered by the bellows.



1.4.7. Table to enter serial no. and distributor

Must be filled in before machine is put into service:

Machine serial No.:

Engine serial No.:

Name of Dealer:

Phone:

Address:

Fax:

Service Personnel for your machine:

E-mail

1.5. Table of contents

1. Introduction	1-1
1.1. Foreword.....	1-2
EU Directives	1-3
1.2. Safety information.....	1-5
1.3. Introduction	1-7
1.3.1. Intended use	1-7
1.3.2. Breaking-in the machine	1-8
1.4. Location of plates	1-9
1.4.1. Machine identification plate	1-9
1.4.2. Engine name-plate.....	1-9
1.4.3. Axle serial no. plate	1-10
1.4.4. Transmission serial no. plate	1-10
1.4.5. ROPS/FOPS-Cab serial no. plate.....	1-10
1.4.6. Operator's seat serial no. plate.....	1-11
1.4.7. Table to enter serial no. and distributor	1-11
1.5. Table of contents	1-12
1.6. Dimensions, weights and operating data	1-19
1.7. CE-conforming equipment.....	1-20
1.7.1. CE-conforming equipment – part 1	1-20
1.7.2. CE-conforming equipment – part 2.....	1-21
1.7.3. Manufacturer-supplied CE-conforming equipment	1-22
1.8. Loading and securing.....	1-25
2. Safety	2-1
2.1. General safety measures.....	2-2
2.1.1. Safety instructions	2-2
2.1.2. Safety devices	2-2
2.1.3. Emergency exit.....	2-2
2.1.4. Clothing and personal protection	2-3
2.1.5. Machine modifications	2-3
2.1.6. Before you leave the driver's seat	2-3
2.1.7. Mounting and dismounting.....	2-4
2.1.8. Fire prevention and fire fighting	2-4
2.1.9. Protection against asbestos dust.....	2-5
2.1.10. Protection against injuries.....	2-5
2.1.11. Working at high temperatures.....	2-6
2.1.12. Roll-over protection system (ROPS).....	2-6
2.1.13. Attachment for protection against falling objects (FOPS)	2-6
2.1.14. Attachments.....	2-7

2.1.15. Battery	2-7
2.2. Safety precautions during operation	2-8
2.2.1. Prior to daily starting up	2-8
Workplace safety	2-8
In the driver's cab	2-8
Indoor operation	2-9
Gas, dust, and inflammable vapours	2-9
Mirrors, windows and lighting	2-9
2.2.2. Machine operation	2-10
Before you start the engine.....	2-10
Reversing.....	2-10
Driving.....	2-11
Driving on slopes	2-11
Emergency Lowering System	2-12
Working close to power lines	2-13
Loading	2-14
Good Vision	2-14
Working on snow	2-14
Height limitation	2-15
Brakes	2-15
Working on loose soil.....	2-15
Working with the forklift truck attachment	2-15
Parking the machine	2-17
2.2.3. Transport	2-18
Loading and unloading the machine.....	2-18
Transport	2-18
2.3. Precautions for maintenance.....	2-19
2.3.1. Personnel	2-19
2.3.2. Before carrying out maintenance.....	2-19
2.3.3. During maintenance.....	2-22
2.3.4. Tyres.....	2-26
2.4. Safety labels on the machine.....	2-28
2.4.1. Positions and order numbers of safety labels.....	2-28
3. Operation.....	3-1
3.1. General view.....	3-2
3.1.1. General view of the machine	3-2
3.1.2. Controls and indicators	3-3
Overall view	3-3
Switches, controls and warning lights.....	3-4
3.2. Description of the individual elements	3-5
3.2.1. Instrument panel.....	3-5
Warning lights	3-6
Control lamps.....	3-8

Measuring indicators.....	3-13
3.2.2. Switches	3-15
3.2.3. Control levers and pedals	3-23
3.2.4. Articulated steering locking	3-28
3.2.5. Traction device	3-28
3.2.6. Socket (12 V)	3-29
3.2.7. Door unlocking system	3-29
3.2.8. Alarm horn for reverse driving – option.....	3-29
3.2.9. Fuses	3-30
3.2.10. Slow-blowing fuses	3-31
3.2.11. Adjusting the heater and ventilation system	3-32
3.2.12. Air-conditioning	3-33
3.3. Operation	3-34
3.3.1. Pre-start checks	3-34
Visual inspection	3-34
Pre-start checks	3-36
Adjustments prior to machine start	3-41
Adjusting the driver’s seat.....	3-41
3.3.2. Starting the engine.....	3-45
Warming up the engine.....	3-46
3.3.3. Driving with the machine.....	3-47
Start-up	3-47
Limiting the maximum speed	3-48
3.3.4. Changing the driving direction	3-50
3.3.5. Turning and steering.....	3-51
3.3.6. Braking.....	3-52
3.3.7. Stopping the machine	3-54
3.3.8. Operating the work equipment.....	3-55
Multifunctional lever	3-55
Control lever for special equipment	3-56
Switching lever of bucket	3-57
3.3.9. Working with the wheel loader.....	3-58
Tyre-appropriate operation	3-58
Switching on the 100 % differential lock (if equipped)	3-58
Loading work	3-59
Removal work	3-59
Excavation work.....	3-61
Planing.....	3-62
Transporting.....	3-63
Unloading.....	3-63
Working with the forklift truck attachment	3-64
3.3.10. Precautions for special operations.....	3-66
Permissible water depth	3-66
Working on snow	3-66
Dumping on steep slopes	3-66
Working in the vicinity of electrical overhead lines.....	3-66
Operation on slopes.....	3-66

Working on loose soil.....	3-66
If the service brake breaks down.....	3-66
Precautionary measures when driving up or down.....	3-67
Precautionary measures during machine travel.....	3-68
3.3.11. Adjusting the position of the work equipment.....	3-69
Selecting a work unit.....	3-69
Removing the work unit.....	3-71
Picking up the multi-purpose bucket.....	3-72
Removing the multi-purpose bucket.....	3-74
Level indicator for the bucket.....	3-74
3.3.12. Parking the machine.....	3-75
3.3.13. Switching off the engine.....	3-76
3.3.14. Check after stopping the engine.....	3-76
3.3.15. Locking.....	3-76
3.3.16. Tyre handling.....	3-77
Precautionary measures when handling tyres.....	3-77
Tyre pressure.....	3-77
3.4. Transporting the machine.....	3-79
3.4.1. Securing the articulated steering.....	3-79
3.4.2. Lifting the machine.....	3-80
3.4.3. Driving the machine onto loading area of transport vehicle.....	3-81
3.4.4. Securing the machine during the transport.....	3-82
3.4.5. After transport.....	3-82
3.5. Cold weather operation.....	3-83
3.5.1. Before the cold season.....	3-83
3.5.2. Precautions after completion of work.....	3-84
3.5.3. After the cold season.....	3-84
3.6. Long-term storage.....	3-85
3.6.1. Before storage.....	3-85
3.6.2. During storage.....	3-85
3.6.3. After storage.....	3-86
4. Troubleshooting.....	4-1
4.1. Towing the machine.....	4-2
4.2. Starting the engine with a booster cable.....	4-6
4.3. For insufficient braking effect.....	4-8
4.3.1. Checking the service brake.....	4-8
4.3.2. Checking the parking brake function.....	4-8
4.4. Emergency steering properties.....	4-9
4.5. Emergency lowering.....	4-9
4.6. Other troubles.....	4-10
4.6.1. Electrical system.....	4-10

4.6.2. Engine.....	4-11
4.6.3. Hydraulic system	4-14
4.6.4. Brakes.....	4-16
4.6.5. Steering	4-16
4.6.6. Axles	4-17
4.6.7. Driver's cab.....	4-17
5. Maintenance	5-1
5.1. Maintenance guide.....	5-2
5.2. Maintenance basics	5-12
5.2.1. Oil, fuel and coolant specifications	5-12
Oil	5-12
Fuel.....	5-13
Coolant	5-14
Grease	5-14
Storing oil and fuel	5-15
Filters	5-15
Biodegradable hydraulic oil and lubricants	5-15
5.2.2. Specifications of the electrical system	5-16
5.2.3. Wearing parts list.....	5-17
5.3. Lubricants, fuels and filling capacities.....	5-18
5.4. Tools.....	5-19
5.4.1. Introduction of recommended tools	5-19
5.5. Periodical replacement of safety-critical parts	5-20
5.6. Maintenance schedule chart.....	5-21
5.7. Service procedure.....	5-23
5.7.1. Pre-start checklist	5-23
Cooling system – checking the coolant level, topping up coolant.....	5-23
Cleaning the radiator segments.....	5-24
V-Belt, checking the condition.....	5-24
Engine, checking the oil level, topping up oil	5-25
Checking the fuel level – refuelling	5-27
Additional water separator (optional)	5-28
Water separator at the fuel filter – Draining water and dirt sediments	5-28
Checking the controls	5-29
Checking the electrical connections	5-29
Heater/air conditioning – checking rate of air flow	5-30
Miscellaneous tests before starting work.....	5-30
5.7.2. Maintenance upon demand	5-31
Checking the air-conditioning system	5-31
Checking the window washing-fluid level, adding fluid	5-32
Re-charging a built-in battery.....	5-33
5.7.3. Maintenance after the first 50 operating hours	5-34

	Hydraulic system, replacing the filter insert	5-34
	Checking and tightening the wheel nuts	5-35
5.7.4.	Maintenance after the first 250 operating hours	5-36
	Front and rear axle – oil change	5-36
	Transfer box – changing oil	5-37
	Checking and adjusting the valve clearance	5-38
5.7.5.	Maintenance every 10 operating hours	5-38
	Lubrication of articulated steering	5-38
5.7.6.	Maintenance every 50 operating hours	5-39
	Battery – checking the acid level	5-39
	Lubrication of work unit	5-40
5.7.7.	Maintenance every 250 operating hours	5-41
	Service brake – Checking the brake pads	5-41
	V-Belt, generator – checking and adjusting the tension	5-41
	Air filter, removing and re-installing the filter insert, checking and cleaning the filter insert	5-43
	Lubrication, steering cylinder	5-46
	Lubrication, self-aligning bearings of rear axle	5-47
	Checking and tightening the wheel nuts	5-48
5.7.8.	Maintenance every 500 operating hours	5-49
	Hand pump - Checking the oil level	5-49
	Service brake - Checking the brake pads and brake discs, checking the oil level	5-49
	Engine – changing oil	5-51
	Replacing the oil filter cartridge	5-52
	Changing the fuel filter element	5-53
	Bleeding the fuel system	5-54
	Bleeding the low pressure side:	5-54
	Bleeding the high pressure side:	5-54
	Air filter, replacing the filter insert, replacing the safety filter	5-55
	Heater/air conditioning – cleaning/replacing filter fleece	5-56
	Multi-functional lever accumulator - checking gas pressure	5-57
	E.C.S.S.-pressure accumulator (Option) - checking gas pressure	5-57
	Front and rear axle – checking the oil level	5-58
	Transfer box – checking and refilling oil	5-59
5.7.9.	Maintenance every 1000 operating hours	5-60
	V-Belt, generator – checking and adjusting the tension	5-60
	Service Brake - Checking and refilling oil	5-60
	Checking and adjusting system pressures	5-60
	Hydraulic – Exchanging the venting filter	5-61
	Hydraulic system, replacing the filter insert	5-62
5.7.10.	Maintenance every 1500 operating hours	5-63
	Front and rear axle – changing oil	5-63
	Transfer box – changing oil	5-64
5.7.11.	Maintenance every 2000 operating hours	5-65
	Cooling system – exchanging coolant and cleaning the system	5-65
	Checking and adjusting the valve clearance	5-67
	Hydraulic system - changing oil	5-68
	Ventilating the hydraulic oil tank	5-69
	Checking the fuel pump	5-70

Checking the fuel and coolant tubes, replacing the tubes (if required)	5-70
Checking the water pump	5-70
5.7.12. Maintenance every 4000 operating hours	5-71
Lubrication, drive shaft.....	5-71
6. Technical data	6-1
6.1. Technical data	6-2
6.2. Noise emission levels.....	6-3
6.3. Vibration levels.....	6-3
Operating condition	6-3
Guide to Reduce Vibration Levels on Machine.....	6-3
6.4. Limit values for slopes	6-5
7. Special equipment and attachments.....	7-1
7.1. E.C.S.S-electronics	7-2
7.1.1. Structure and functioning principle of the E.C.S.S-electronics	7-2
7.1.2. Precautionary measures for switching on the E.C.S.S-electronics.....	7-2
7.1.3. Operating the E.C.S.S-electronics.....	7-3
Switching ON the E.C.S.S.-electronics.....	7-3
Switching OFF the E.C.S.S-electronics	7-3
7.1.4. Precautions when handling the accumulator	7-4
7.2. Bucket position indicator	7-5
8. Index.....	8-1
9. Notes	9-1

1.6. Dimensions, weights and operating data

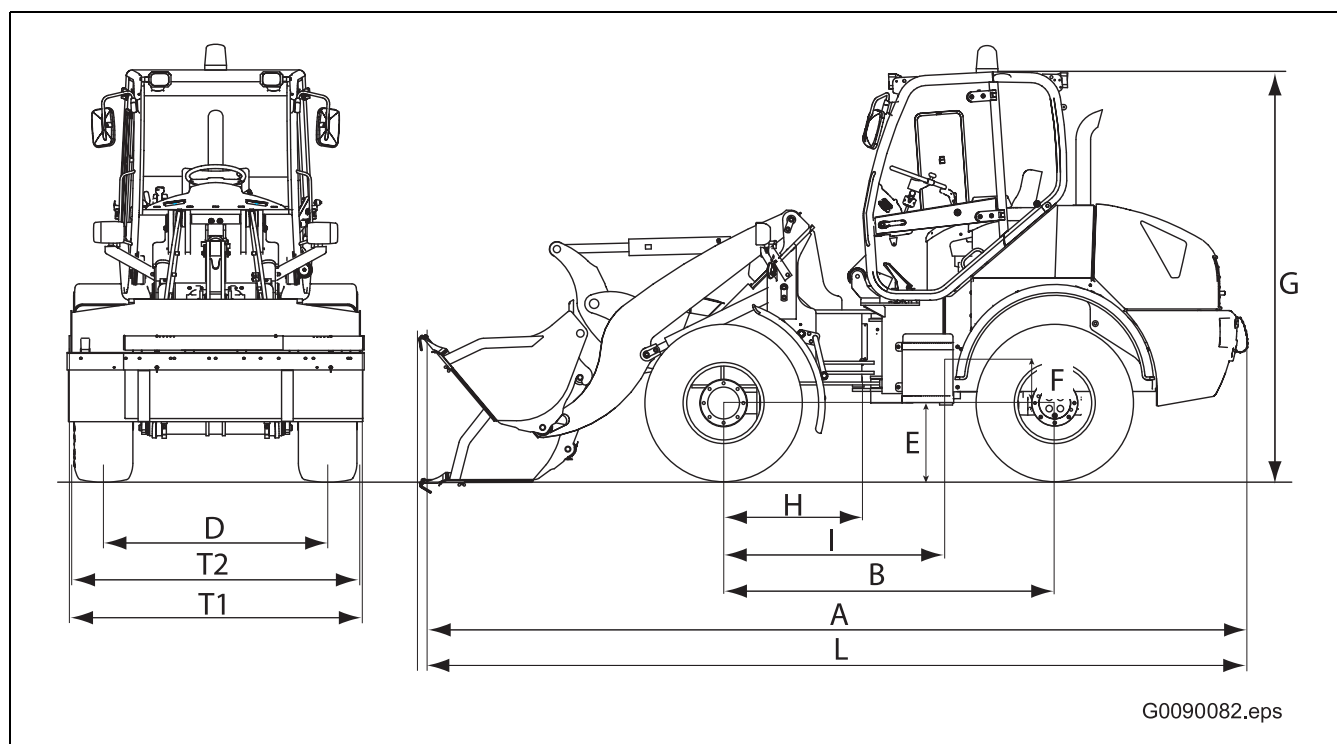

Dimensions, weights and operating data

	Bucket capacity to ISO 7546	m ³	1,05	
	Material density	t/m ³	1,8	
	Static tipping load, straight	kg	4890	
	Static tipping load, 40° angle	kg	4115	
	Working load	kg	2400	
	Breakout force, hydraulic	kN	63,5	
	Lifting capacity, hydraulic, on ground	kN	59,8	
	Operating weight	kg	6400	
	Turning radius over bucket	mm	4390	
L	Bucket length in transport position	mm	5560	with teeth 5645
A	Bucket length during planing	mm	5590	with teeth 5730
T1	Width with bucket	mm	2050	
T2	Width without bucket (above wheels)	mm	1990	
G	Height, including ROPS	mm	2820	
D	Track	mm	1590	405/70 R20 SPT9 tyres
B	Width over tyres	mm	2300	
H	Distance articulated steer. - front axle	mm	1100	
E	Ground clearance, axle /transfer gear	mm	350	
	ground clearance, drive shaft	mm	460	
F	Centre of gravity, height above axle centre	mm	385	CTW = additional counterweight
I	Centre of gravity, distance to front axle	mm	1452	