

Operation & Maintenance Manual

WA380-6H

WHEEL LOADER

SERIAL NUMBERS H60051 and up



WARNING

Unsafe use of this machine may cause serious injury or death. Operators and maintenance personnel must read this manual before operating or maintaining this machine. This manual should be kept near the machine for reference and periodically reviewed by all personnel who will come into contact with it.

NOTICE

Komatsu has had the operating and maintenance instructions translated into all the languages of the member states in the European Union. Should you wish to have a version of the operating instructions in another language, please don't hesitate to ask at your local dealer's.

1. Foreword

1.1 Foreword

This manual provides rules and guidelines which will help you use this machine safely and effectively. The precautions in this manual must be followed at all times when performing operation and maintenance. Most accidents are caused by the failure to follow fundamental safety rules for the operation and maintenance of machines. Accidents can be prevented by knowing beforehand conditions that may cause a hazard when performing operation and maintenance.



WARNING

- Operators and maintenance personnel must always do as follows before beginning operation or maintenance.
- Always be sure to read and understand this manual thoroughly before performing operation and maintenance.
- Read the safety messages given in this manual and the safety labels affixed to the machine thoroughly and be sure that you understand them fully.
- Keep this manual at the storage location for the Operation and Maintenance Manual given below, and have all personnel read it periodically.
- If this manual has been lost or has become dirty and cannot be read, request a replacement manual immediately from KOMATSU or your KOMATSU distributor.
- If you sell the machine, be sure to give this manual to the new owners together with the machine.
- KOMATSU delivers machines that comply with all applicable regulations and standards of the country to which it has been shipped. If this machine has been purchased in another country or purchased from someone in another country, it may lack certain safety devices and specifications that are necessary for use in your country. If there is any question about whether your product complies with the applicable standards and regulations of your country, consult KOMATSU or your KOMATSU distributor before operating the machine.

Storage location for the Operation and Maintenance Manual:
Pocket (1) at rear of operator's seat

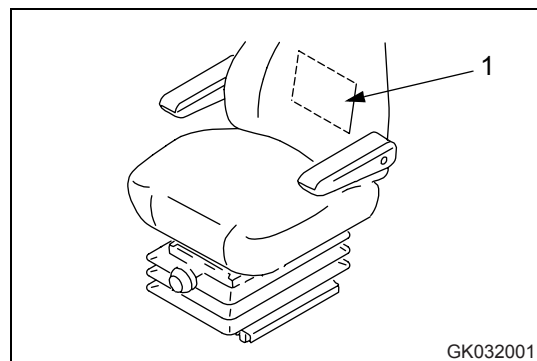

GK032001

1.1.1 EU Directives

Machines supplied by us fulfil the Directive for Machinery 89/392/EEC and all supplements. If the machine is being used in another country, it is possible that certain safety regulations and specifications may not be fulfilled for use in that country. For example, priority vehicle warning lamps may be used in some countries, but are forbidden in others.

Please contact our dealer before using the machine if you have any questions regarding the fulfilment of standards and regulations in a specific country.

Notes on subsequent installation of electrical and electronic equipment and components

Electrical and electronic equipment and/or components which have been installed subsequently, emit electromagnetic radiation which can influence the function of the electronic components and sections of the machine. This can have an influence on the safety of the machine and endanger persons. For this reason, please ensure that the following safety instructions are observed.

If you are installing electrical or electronic equipment and/or components in the machine and connect them to the vehicle electrical system, you must check at own responsibility that the installations do not cause any disturbance to the vehicle's electronic system or other components. Above all, you must ensure that any subsequently installed electrical and electronic components comply with the EMV Directive 89/336/EEC in its current edition and bear the CE mark.

The following requirements also have to be met for subsequent installation of mobile communication systems (e.g. radio, telephone):

- Only equipment approved by national legislation (e.g. BZT approval for Germany) may be used
- The unit must be fixed in position
- Portable or mobile units may only be used inside the vehicles if they are connected to a fixed outside antenna
- The transmitter unit must be spatially separated from the vehicle's electronic system
- Make sure when installing the antenna that this is installed correctly with good earth connection between antenna and vehicle mass

Also observe KOMATSU and manufacturer's installation instructions for wiring, installation and maximum permitted power consumption.

1.2 Safety information

To enable you to use this machine safely, safety precautions and labels are given in this manual and affixed to the machine to give explanations of situations involving potential hazards and of the methods of avoiding such situations.

1.2.1 Signal words

The following signal words are used to inform you that there is a potential hazardous situation that may lead to personal injury or damage.

In this manual and on machine labels, the following signal words are used to express the potential level of hazard.

DANGER

Indicates an imminently hazardous situation which, if not avoided, will result in death or serious injury.

WARNING

Indicates a potentially hazardous situation which, if not avoided, could result in death or serious injury.

CAUTION

Indicates a potentially hazardous situation which, if not avoided, may result in minor or moderate injury. This word is used also to alert against unsafe practices that may cause property damage.

Example of safety message using signal word

WARNING

When standing up from the operator's seat, always place the work equipment lock lever in the LOCK position.
If you accidentally touch the control levers when they are not locked, this may cause a serious injury or death.

Other signal words

In addition to the above, the following signal words are used to indicate precautions that should be followed to protect the machine or to give information that is useful to know.

NOTE

This word is used for precautions that must be taken to avoid actions which could shorten the life of the machine.

REMARK

This word is used for information that is useful to know.

1.2.2 Safety labels

Safety labels are affixed to the machine to inform the operator or maintenance worker on the spot when carrying out operation or maintenance of the machine that may involve hazard.

For details of safety labels, see "Safety labels (2-2)".

Safety labels using pictogram

Safety pictograms use a picture to express a level of hazardous condition equivalent to the signal word. These safety pictograms use pictures in order to let the operator or maintenance worker understand the level and type of hazardous condition at all times. Safety pictograms show the type of hazardous condition at the top or left side, and the method of avoiding the hazardous condition at the bottom or right side. In addition, the type of hazardous condition is displayed inside a triangle and the method of avoiding the hazardous condition is shown inside a circle.

KOMATSU cannot predict every circumstance that might involve a potential hazard in operation and maintenance. Therefore, the safety messages in this manual and on the machine may not include all possible safety precautions.

If any procedures or actions not specifically recommended or allowed in this manual are used, it is your responsibility to take the necessary steps to ensure safety.

In no event should you engage in prohibited uses or actions described in this manual.

The explanations, values, and illustrations in this manual were prepared based on the latest information available at that time. Continuing improvements in the design of this machine can lead to changes in detail which may not be reflected in this manual. Consult KOMATSU or your KOMATSU distributor for the latest available information of your machine or for questions regarding information in this manual.



1.3 Introduction

This loader is a machine with independent transmission, moving on chains or wheels. Driving in forward direction, the loader can load or dig material using its attachments intended for loading operations (i.e. bucket).

This KOMATSU machine is designed to be used mainly for the following work:

- Digging work
- Smoothing
- Pushing work
- Loading work

For details of the operating procedure, see "Work possible using wheel loader (3-122)".

1.3.1 Intended use

If you use the machine for any other purpose than specified above, we will not accept any responsibility for safety. All considerations concerning safety will then be up to the owner or the operating and maintenance personnel. In any case, neither you nor any other person are/is authorised to perform work and functions explicitly prohibited in these operating instructions.

The transport of persons in the work equipment is strictly forbidden!

For details of the operating procedure, see "Work possible using wheel loader (3-122)".

1.3.2 Directions of machine

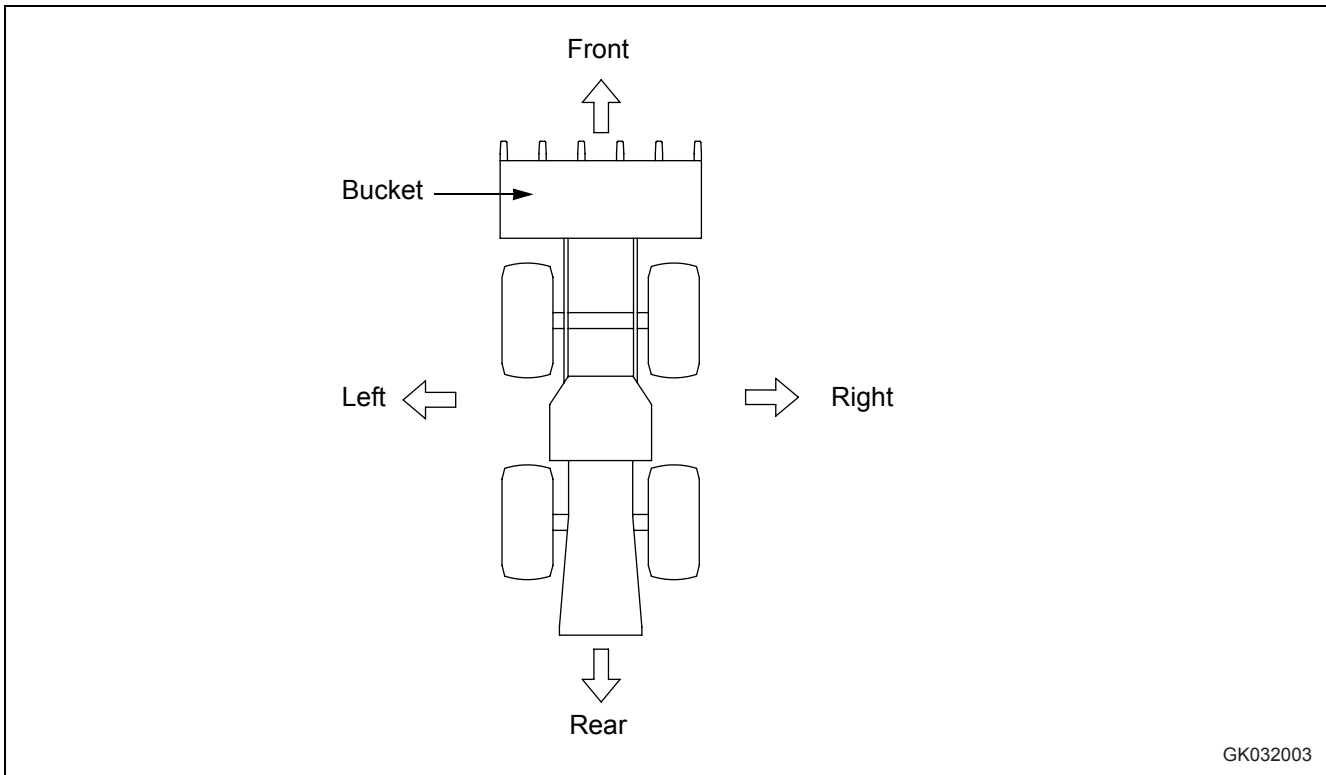

In this manual, the directions of the machine (front, rear, left, right) are determined according to the view from the operator's seat in the direction of travel (front) of the machine.

1.3.3 Visibility from operator's seat

The visibility standards (ISO 5006) for this machine require a view shown in the diagram on the right side.

Visibility in immediate area

The visibility of this machine in the area 1 m from the outside surface of the machine at a height of 1.5 m is shown in the diagram on the right side. The hatched area (A) shows the area where the view is blocked by part of the machine when mirrors or other aids to visibility are installed as standard. Please be fully aware that there are places that cannot be seen when operating the machine.

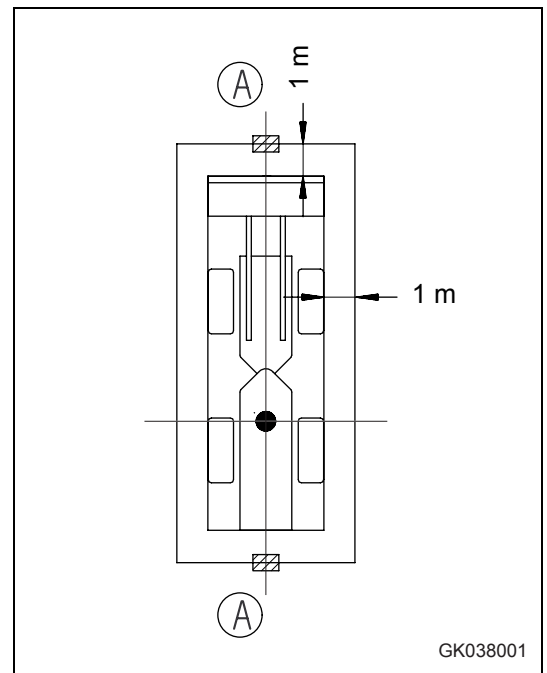

12-M Radius visibility

The visibility at a radius of 12 m from the machine is as shown in the diagram below. The hatched areas (B) show the areas where the view is blocked when mirrors or other aids to visibility are installed as standard. Please be fully aware that there are places that cannot be seen when operating the machine.

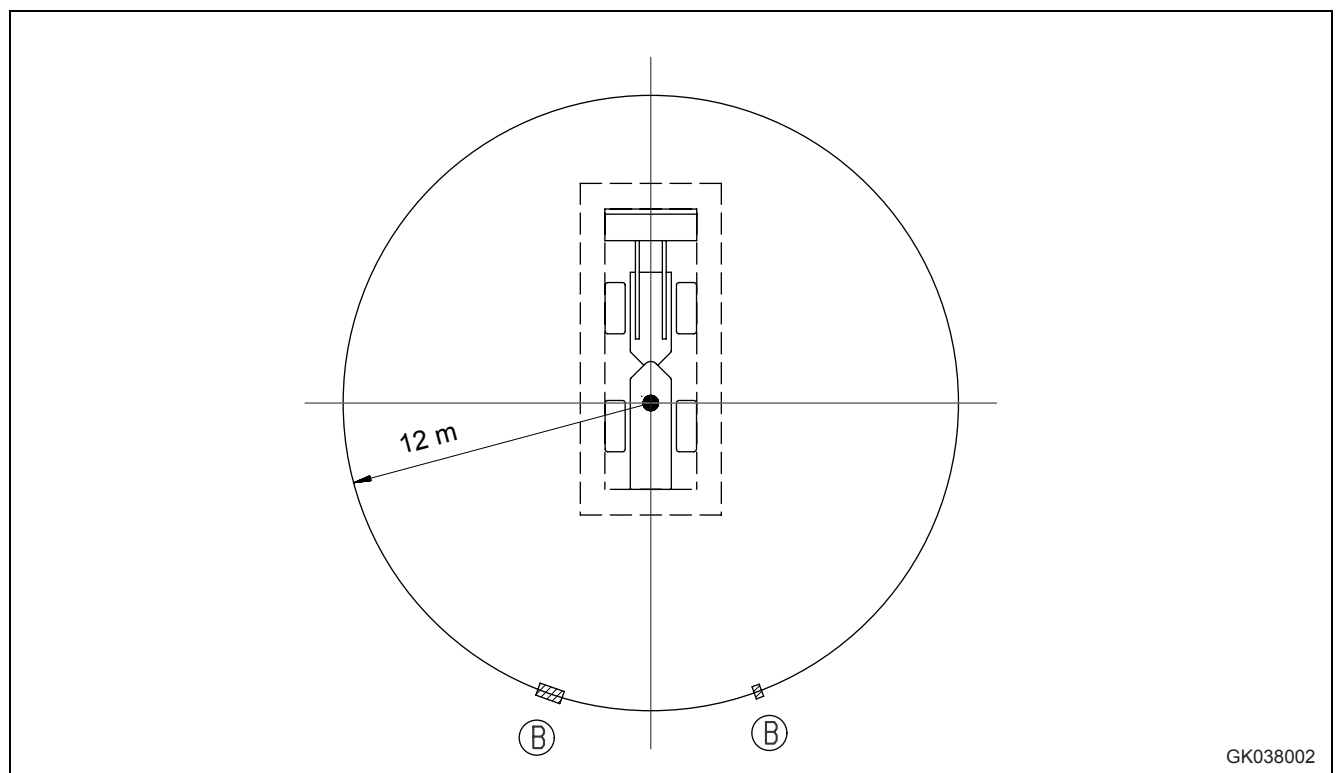

1.4 Necessary information

When requesting service or ordering replacement parts, please inform your KOMATSU distributor of the following items.

1.4.1 Product Identification Number (PIN)/Machine serial no. plate and position

On the center right of the front frame.

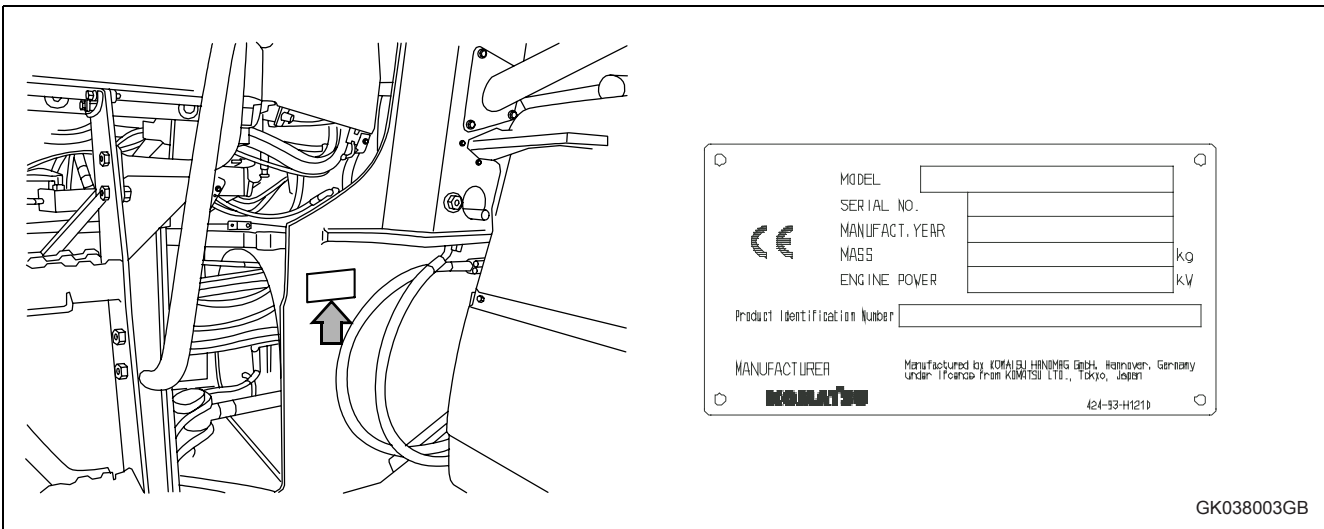

1.4.2 Engine serial no. plate and position

It is at the top at the rear of the engine on the right side of the machine.

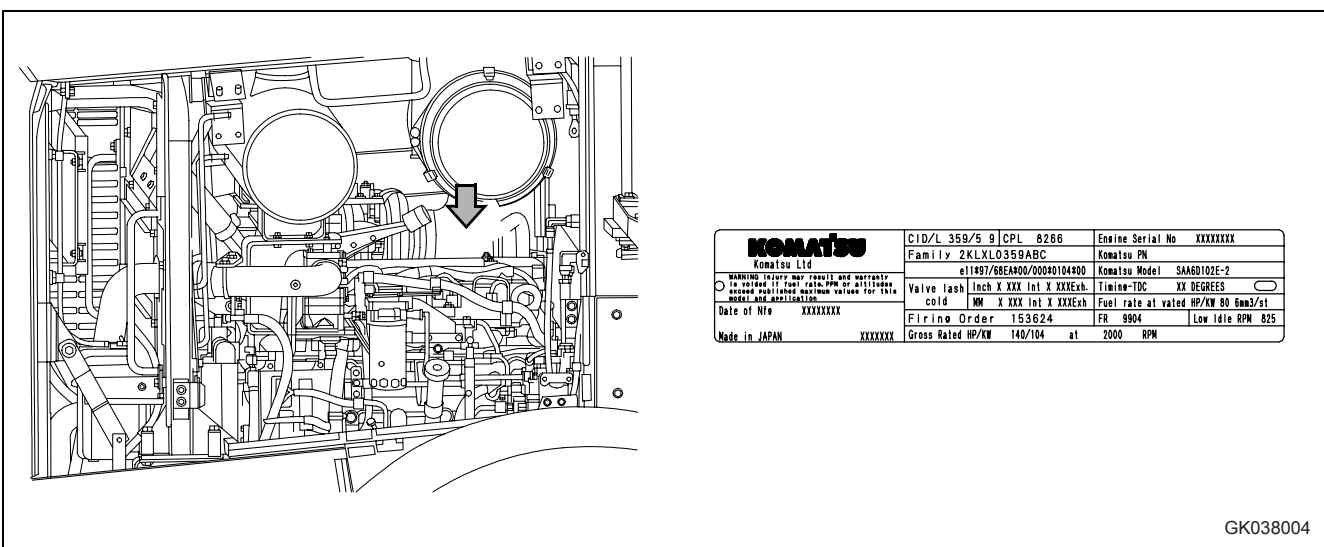

EPA: Environmental Protection Agency, U.S.A.

1.4.3 ROPS/FOPS-Cab serial no. plate

This plate is located on the right inside cab on the rear beam.

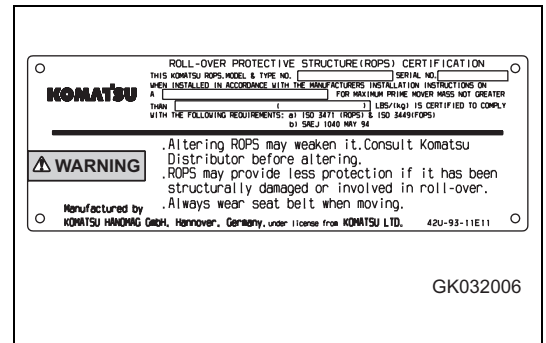

1.4.4 Axle serial no. plate

This plate is located on the right of front axle and on the left of rear axle.

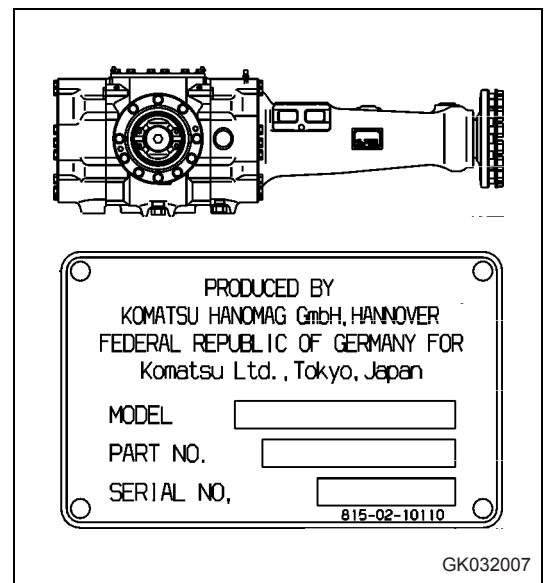

1.4.5 Transmission serial no. plate

This plate is located in travel direction front, above the transmission output.

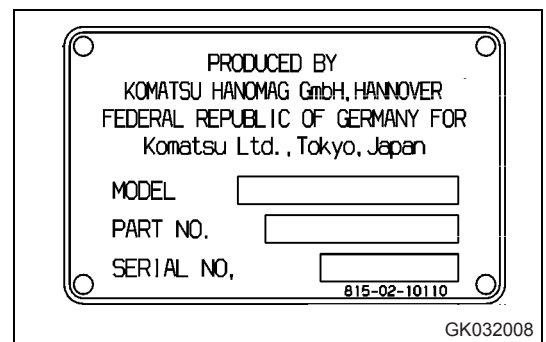

1.4.6 Seat operator serial no. plate

This plate is located in front of seat, covered by the bellows.

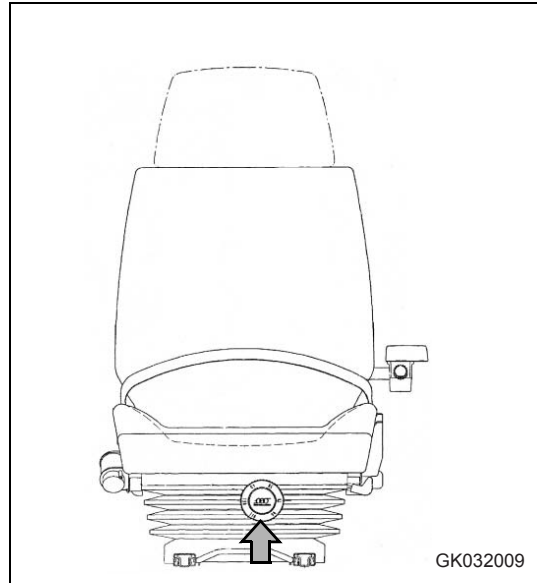

1.4.7 Position of service meter

The service meter is displayed on the character display at the bottom center of the machine monitor.

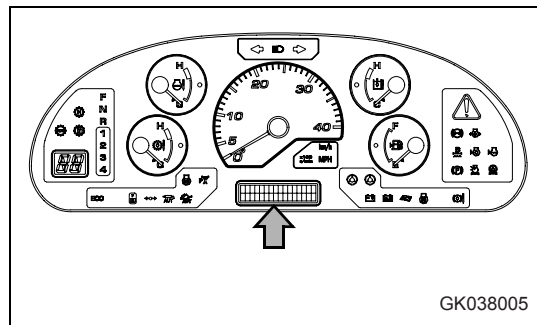

1.4.8 Table to enter serial no. and distributor

Machine serial No.	
Engine serial No.	
Product identification number (PIN)	
Distributor name	
Address	
Service Personnel	
Phone/Fax	

1.5 Contents

1.	Foreword	1-1
1.1	Foreword	1-2
1.1.1	EU Directives	1-3
1.2	Safety information	1-4
1.2.1	Signal words	1-4
1.2.2	Safety labels	1-6
1.3	Introduction	1-7
1.3.1	Intended use	1-7
1.3.2	Directions of machine	1-8
1.3.3	Visibility from operator's seat	1-9
1.4	Necessary information	1-10
1.4.1	Product Identification Number (PIN)/Machine serial no. plate and position	1-10
1.4.2	Engine serial no. plate and position	1-10
1.4.3	ROPS/FOPS-Cab serial no. plate	1-11
1.4.4	Axle serial no. plate	1-11
1.4.5	Transmission serial no. plate	1-11
1.4.6	Seat operator serial no. plate	1-12
1.4.7	Position of service meter	1-12
1.4.8	Table to enter serial no. and distributor	1-12
1.5	Contents	1-13
1.6	Dimensions, weights and operating data	1-21
1.6.1	WA380-6: Dimensions, weights and operating data	1-21
1.7	CE-Conforming equipment	1-22
1.7.1	CE-Conforming equipment	1-22
1.7.2	Manufacturer-supplied CE-Conforming equipment, according to document 419-93-H1250	1-23
2.	Safety	2-1
2.1	Safety labels	2-2
2.1.1	Location of safety labels	2-2
2.1.2	Presentation of safety labels	2-3
2.2	General precautions	2-6
2.3	Precautions for operation	2-18
2.3.1	Starting engine	2-18
2.3.2	Operation	2-20
2.3.3	Transportation	2-28
2.3.4	Battery	2-30
2.3.5	Towing	2-32
2.4	Precautions for maintenance	2-33
2.5	Precautions with tires	2-43

3.	Operation	3-1
3.1	General view	3-2
3.1.1	General view of machine	3-2
3.1.2	General view of controls and gauges	3-3
3.2	Explanation of components	3-7
3.2.1	Machine monitor	3-7
	Types of warning	3-8
	Central warning lamp	3-9
	Character display portion	3-10
	Emergency stop item	3-16
	Caution items	3-19
	Inspection and maintenance item	3-22
	Pilot display portion	3-26
	Meter display portion	3-32
	Other functions of machine monitor	3-35
3.2.2	Switches	3-40
3.2.3	Control levers, pedals	3-57
3.2.4	Steering tilt lock lever	3-64
3.2.5	Cap with lock	3-65
3.2.6	Safety bar	3-66
3.2.7	Towing pin	3-67
3.2.8	Grease pump	3-67
3.2.9	Cab door	3-68
3.2.10	Cab door open lock	3-68
3.2.11	Cab window open lock	3-69
	Cab left window open lock reset knob	3-69
	Cab right window open lock reset knob	3-69
	Reset right window open lock for escape	3-70
3.2.12	Backup alarm	3-70
3.2.13	Fuse	3-71
	Fuse capacity and name of circuit	3-71
3.2.14	Slow blow fuse	3-72
3.2.15	Power outlet	3-73
3.2.16	Air conditioner	3-74
	General locations and function of control panel	3-74
	Method of operation	3-77
	Precautions when using	3-79
	Precautions for inspection and maintenance	3-79
	Cool box	3-80
3.2.17	Handling cab wiper	3-80
	Preventing damage to wiper arm bracket	3-80
3.3	Operation	3-81
3.3.1	Check before starting engine, adjust	3-81
	Walk-around check	3-81
	Check before starting	3-84
	Adjustment	3-92
	Safety belt	3-93

	Adjust lever stand	3-94
	Operations and checks before starting engine	3-96
3.3.2	Starting engine	3-98
	Normal starting	3-98
	Starting in cold weather	3-100
	Automatic warming-up operation	3-101
3.3.3	Operations and checks after starting engine	3-102
	Breaking-in the machine	3-102
	Normal operation	3-103
3.3.4	Stopping engine	3-105
3.3.5	Check after stopping engine	3-105
3.3.6	Moving the machine (directional, speed), stopping the machine	3-106
	Preparations for moving the machine	3-106
	Changing gear speed	3-109
	Changing direction	3-110
	Using switch to change between forward and reverse	3-112
	Stopping the machine	3-114
	Transmission cut-off function	3-115
3.3.7	Turning	3-117
	Emergency steering	3-118
3.3.8	Operation of work equipment	3-120
	Lift arm operation	3-121
	Bucket operation	3-121
3.3.9	Work possible using wheel loader	3-122
	Digging operations	3-122
	Leveling operation	3-126
	Pushing operation	3-126
	Load and carry operations	3-127
	Loading operations	3-127
3.3.10	Precautions for operation	3-129
	Permissible water depth	3-129
	If wheel brake does not work	3-129
	Precautions when driving up or down slopes	3-129
3.3.11	Adjusting work equipment posture	3-131
	Adjusting boom kickout	3-132
	Adjusting bucket positioner	3-132
	Bucket level indicator	3-133
3.3.12	Parking machine	3-133
3.3.13	Checks after completion of operation	3-135
	Before stopping engine	3-135
	After stopping engine	3-135
3.3.14	Locking	3-136
3.3.15	Handling the tires	3-137
	Precautions when handling tires	3-137
	Tire pressure	3-137
	Precautions for using load and carry method	3-138

3.4	Transportation	3-139
3.4.1	Transportation procedure	3-139
3.4.2	Loading, unloading work with trailers	3-139
	Loading	3-140
	Securing machine	3-140
	Unloading	3-142
3.4.3	Lifting machine	3-143
	Location of lifting position mark	3-144
	Weight table	3-144
	Lifting procedure	3-145
3.5	Cold weather operation	3-146
3.5.1	Precautions for low temperature	3-146
	Fuel and lubricants	3-146
	Coolant	3-146
	Battery	3-147
3.5.2	Precautions after completion of work	3-148
3.5.3	After cold weather	3-148
3.5.4	Warming-up operation for steering hydraulic circuit in cold weather	3-149
3.6	Long-term storage	3-150
3.6.1	Before storage	3-150
3.6.2	During storage	3-150
3.6.3	After storage	3-151
3.7	Troubleshooting	3-152
3.7.1	When machine runs out of fuel	3-152
3.7.2	Towing the machine	3-152
	When engine can be used	3-154
	When engine cannot be used	3-154
	Releasing parking brake	3-155
	Emergency travel operation	3-157
3.7.3	If battery is discharged	3-158
	Removal and installation of battery	3-159
	Precautions for charging battery	3-160
	Starting engine with booster cable	3-161
3.7.4	Other trouble	3-163
	Electrical system	3-163
	Chassis	3-164
	Engine	3-166
4.	Maintenance	4-1
4.1	Guides to maintenance	4-2
4.2	Outlines of service	4-6
4.2.1	Handling oil, fuel, coolant, grease and carrying out KOWA (KOMATSU Oil Wear Analysis)	4-7
	Oil	4-7
	Fuel	4-8
	Coolant and water for dilution	4-9
	Grease	4-10

	Carrying out KOWA (KOMATSU Oil Wear Analysis)	4-10
	Storing oil and fuel	4-12
	Filters	4-12
4.2.2	Outline of electric system	4-13
4.3	Wear parts	4-14
4.3.1	Wear parts list	4-14
4.4	Fuel, coolant and lubricants	4-16
4.4.1	Lubrication chart.	4-18
4.4.2	Use of fuel, coolant and lubricants according to ambient temperature	4-19
4.4.3	Recommended brands, recommended quality for products other than KOMATSU genuine oil	4-22
4.5	Standard tightening torques for bolts and nuts	4-23
4.5.1	Torque list.	4-23
4.6	Periodic replacement of safety critical parts	4-25
4.7	Maintenance schedule chart	4-27
4.7.1	Maintenance schedule chart	4-27
4.8	Replace injector assembly	4-30
4.9	Service procedure	4-31
4.9.1	Initial 50 hours service (only after the first 50 hours)	4-31
	Check for loose wheel hub bolts, tighten	4-31
4.9.2	Initial 250 hours service (only after the first 250 hours)	4-31
	Replace transmission oil filter cartridge	4-31
	Replace hydraulic tank filter element	4-31
4.9.3	Initial 1000 hours service (only after the first 1000 hours)	4-31
	Check engine valve clearance, adjust	4-31
4.9.4	When required	4-32
	Clean, replace air cleaner element.	4-32
	Clean inside of cooling system.	4-35
	Check transmission oil level, add oil	4-39
	Check axle oil level, add oil	4-40
	Clean axle case breather	4-41
	Clean air conditioner condenser.	4-42
	Check window washing fluid level, add fluid	4-42
	Clean radiator fins and cooler fins	4-43
	Check electrical intake air heater	4-46
	Turn, replace bolt on cutting edge	4-47
	Replace bucket teeth	4-48
	Check air conditioner	4-50
	Replace slow blow fuse	4-51
	Checking function of accumulator	4-52
	Selection and inspection of tires.	4-53

4.9.5	Check before starting	4-55
	Check before starting	4-55
4.9.6	Every 50 hours service	4-55
	Drain water, sediment from fuel tank	4-55
4.9.7	Every 100 hours service	4-56
	Lubricate rear axle pivot pin	4-56
	Check oil level in hydraulic tank, add oil	4-56
	Clean element in air conditioner fresh air filter	4-57
4.9.8	Every 250 hours service	4-58
	Check battery electrolyte level	4-58
	Check parking brake	4-61
	Check air conditioner compressor belt tension, adjust	4-61
	Check for loose wheel hub bolts, tighten	4-62
	Clean element in air conditioner recirculation filter	4-63
	Checking function of accumulator	4-64
	Lubricating	4-65
4.9.9	Every 500 hours service	4-66
	Change oil in engine oil pan, replace engine oil filter cartridge	4-66
	Replace fuel pre-filter cartridge	4-68
4.9.10	Every 1000 hours service	4-71
	Replace fuel filter cartridge	4-71
	Change oil in transmission case and transmission oil filter cartridge, clean strainer	4-73
	Clean transmission case breather	4-74
	Lubricating	4-74
	Check tightening parts of turbocharger	4-75
	Check alternator driving belt tension and replacement	4-75
	Replace corrosion resistor cartridge	4-75
4.9.11	Every 2000 hours service	4-76
	Change oil in hydraulic tank, replace hydraulic filter element	4-76
	Replace hydraulic tank breather element	4-79
	Change axle oil	4-80
	Replace element in air conditioner recirculation air filter, fresh air filter	4-81
	Check brake disc wear	4-81
	Checking function of accumulator	4-83
	Check alternator, starting motor	4-84
	Check engine valve clearance, adjust	4-84
	Check vibration damper	4-84
4.9.12	Every 4000 hours service	4-85
	Lubricating	4-85
	Check water pump	4-86
	Check air conditioner compressor, adjust	4-86
	Checking for looseness of high-pressure clamp, hardening of rubber	4-87
	Checking for missing fuel spray prevention cap, hardening of rubber	4-88
4.9.13	Every 8000 hours service	4-89
	Replace high-pressure piping clamp	4-89
	Replace injector nozzle tip	4-89