

Operation & Maintenance Manual

SK1020-5 turbo

SKID-STEER LOADER

SERIAL NUMBER

SK1020-5 turbo 37CTF00432 and up



WARNING

Unsafe use of this machine may cause serious injury or death. Operators and maintenance personnel must read this manual before operating or maintaining this machine.

This manual should be kept inside the cab for reference and periodically reviewed by all personnel who will come into contact with the machine.



1.1 FOREWORD

- This manual is supplied by Komatsu Utility S.p.A. in order to provide customers with all the necessary information on the machine and the safety regulations related to it, together with the use and maintenance instructions that enable the operator to exploit the capacity of the machine with optimal results and to keep the machine efficient over time.
- The operation manual, together with the spare parts catalogue, is an integral part of the machine and must accompany it, even when it is resold, until its final disposal.
- The manual must be handled with the greatest care and always kept on board the machine, so that it can be consulted at any moment; it must be placed in the appropriate compartment, where also the ownership documents and the logbook are usually kept.
- This manual must be given to the persons who have to use the machine and carry out the routine maintenance operations; they must read the contents carefully more than once, in such a way as to clearly understand what are the correct operating conditions and the dangerous conditions that must be avoided.
In case of loss or damage, request a new copy to Komatsu or to your Komatsu Dealer.
- The illustrations contained in this manual may represent machine configurations that are available on request. Komatsu machines are constantly improved in order to increase their efficiency and reliability; this manual sums up all the information regarding the most recent techniques applied at the moment in which the machine is marketed.
For any updated information, contact your Komatsu Dealer.
- Punctual periodic annotations regarding the maintenance operations that have been carried out are important to have a clear prospect of the situation and to know exactly what has been done and what has to be done after the next maintenance interval. Therefore, it is advisable to consult either the hour meter and the maintenance plan frequently.
- Over the years Komatsu Dealers have gathered considerable experience in customer service.
If more information is needed, do not hesitate to contact your Komatsu Utility Dealer: he always knows how to get the best performance from the machine, he can suggest the use of the equipment that is most suitable for specific needs and can provide the technical assistance necessary for any change that may be required to conform the machine to the safety standards and traffic rules.
Furthermore, Komatsu Dealers also ensure their assistance for the supply of Komatsu genuine spare parts, which alone guarantee safety and interchangeability.
- The table included in this manual must be filled in with the machine data, which are the data that must always be indicated to the Dealer when requiring assistance and ordering spare parts.



CAUTION

- **Improper use and maintenance of this machine may be hazardous and cause serious injuries and even death.**
 - **Operators and maintenance personnel must carefully read this manual before using the machine or performing maintenance operations.**
 - **Some actions involved in the operation and maintenance of the machine may cause serious injuries or even death, if they are not performed in compliance with the instructions given herein.**
 - **The procedures and precautions described in this manual are valid for application to the machine only when it is used correctly.**
If the machine is used for any purpose or in any way other than those described herein, the operator shall be responsible for his own safety and for the safety of any other person involved.
-

1.2 INFORMATION ON SAFETY

Many accidents are caused by insufficient knowledge of and failure to comply with the safety regulations prescribed for the maintenance operations that must be performed on the machine.

In order to avoid accidents, before starting work and before carrying out any maintenance operation, carefully read and be sure to understand all the information and warnings contained in this manual and given on the plates applied on to the machine.

To enable you to use this machine safely, safety precautions and labels are given in this manual and affixed to the machine to give explanations of situations involving potential hazards and of the methods of avoiding such situations

Signal words

The following signal words are used to inform you that there is a potential hazardous situation that may lead to personal injury or damage.

In this manual and on machine labels, the following signal words are used to express the potential level of hazard.

DANGER

- Indicates an imminently hazardous situation which, if not avoided, will result in death or serious injury. This signal word is to be limited to most extreme situations.
-

WARNING

- Indicates a potentially hazardous situation which, if not avoided, could result in death or serious injury.
-

CAUTION

- Indicates a potentially hazardous situation which, if not avoided, may result in minor or moderate injury. It may also be used to alert against unsafe practices.
-

Other signal words

In addition to the above, the following signal words are used to indicate precautions that should be followed to protect the machine or to give information that is are useful to know.

IMPORTANT

- This word is used for precautions that must be taken to avoid actions which could shorten the life of the machine.

NOTE

- This gives information that is useful to know.

Komatsu cannot reasonably predict every circumstance that might involve a potential hazard during the operation or maintenance of the machine; for this reason, the safety messages included in this manual and applied on to the machine plates may not include all possible safety precautions.

If all the procedures and operations prescribed for this machine are kept to, you can be sure that the operator and the persons in the vicinity of the machine will work in total safety, with no risk of injuries or damage. In case of doubt regarding the safety measures necessary for some procedures, contact Komatsu or your local Dealer.

DANGER

- Before starting any maintenance operation, position the machine on a firm and level surface, lower the equipment to the ground, engage the safety locks of the equipment and of the controls and stop the engine.
-

DANGER

- To make the information clearer, some illustrations in this manual represent the machine without safety guards. Do not use the machine without guards and do not start the engine when the engine hood is open, unless this is expressly prescribed for some specific maintenance operations.
-

 WARNING

- It is strictly forbidden to modify the setting of the hydraulic system safety valves; Komatsu cannot be held liable for any damage to persons, property or the machine, if this has been tampered with by modifying the standard setting of the hydraulic system.
-

 WARNING

- Before carrying out any electrical welding, disconnect the battery and the alternator (see "2.8.13 PRECAUTIONS CONCERNING THE BATTERY AND THE ALTERNATOR").
-

 WARNING

- Install only authorized additional equipment (see "6.1.4 CHARACTERISTICS OF THE OPTIONAL EQUIPMENT OF THE MACHINE VERSION WITH HIGH FLOW AND SUPER-FLOW HYDRAULIC SYSTEM").
-

 WARNING

- Travel on roads is allowed only if the machine is provided with appropriate lighting, signalling and safety devices and properly authorized by the relevant papers.
Before travelling on roads, make sure that the equipment installed on the machine is homologated and that the safety locks are correctly engaged.
-

 DANGER

- It is absolutely forbidden to operate the machine while standing on the ground.
Every single manoeuvre must be carried out by the operator, correctly seated in driving position.
-

1.3 INTRODUCTION

1.3.1 INTENDED USES

The Komatsu MACHINES described in this manual have been designed and constructed to be used by duly trained personnel mainly for EXCAVATION and EARTH-MOVING OPERATIONS.

If provided with suitable safety devices, they can be used with authorized optional equipment having the characteristics illustrated at point "6.1 AUTHORIZED OPTIONAL EQUIPMENT".

1.3.2 IMPROPER OR UNAUTHORIZED USES

CAUTION

- This paragraph describes some of the improper or unauthorized uses of the machine; since it is impossible to predict all the possible improper uses, if the machine happens to be used for particular applications, contact your Komatsu Dealer before carrying out the work.

IMPORTANT

- The instructions regarding the authorized optional equipment are given in the relevant operation and maintenance manuals; if the equipment is supplied by Komatsu, these publications are attached to this manual.
- The instructions regarding the assembly of the authorized equipment, the controls requiring special arrangements on the machine and the hydraulic couplings necessary for the operation of the equipment are grouped in the final section of this manual.

Komatsu MACHINES are constructed exclusively for the handling, excavation and treatment of inert materials; therefore, the following uses are absolutely forbidden:

- USE OF THE MACHINE BY MINORS OR INEXPERIENCED PERSONS.
- USE OF THE MACHINE FOR LIFTING PERSONS OR OBJECTS.
- TRANSPORT OF CONTAINERS WITH FLAMMABLE OR DANGEROUS FLUIDS.
- USE OF THE BUCKET FOR DRIVING OR EXTRACTING PILES.
- USE OF THE MACHINE FOR TOWING DAMAGED VEHICLES.

1.3.3 MAIN CHARACTERISTICS

- Simple and easy operation.
- Hydrostatic transmission obtained through a double variable displacement pump and axial piston motors operating epicyclic reduction gears.
- Four driving wheels always engaged through oil-immersed roller chains.
- Main equipment and travel control through servo levers ensuring also combined movements that can be modulated proportionally and continually.
- Foot control for the optional equipment (if installed).
- Foot accelerator.
- Lever accelerator.
- Parking brake control.
- Complete series of instruments visible from the operating position.
- Easy maintenance with simplified intervals.
- Road travel (on request).

1.3.4 RUNNING-IN

Every machine is scrupulously adjusted and tested before delivery.

A new machine, however, must be used carefully for the first 100 hours, in order to ensure proper running-in of the various components.

If the machine is subjected to excessive work load at the beginning of operation, its potential yield and its functionality will be untimely reduced.

Every new machine must be used carefully, paying special attention to the following indications:

- After starting the engine, let it idle for 5 minutes, in such a way as to warm it up gradually before actual operation.
- Avoid operating the machine with the limit loads allowed or at high speed.
- Avoid abrupt starts or accelerations, useless sudden decelerations and abrupt reversals.
- After the first 50 hours of use, carry out the following operations, in addition to those to be performed every 50 hours:
 - 1 - Check the gearing chain tension.
 - 2 - Check the wheel nut tightening.
- After the first 250 hours of use, carry out the following operations, in addition to those to be performed every 250 hours:
 - 1 - Change the hydraulic circuit drain filter.

SYNTHETIC BIODEGRADABLE OIL TYPE HEES

On machines in which the synthetic biodegradable oil type HEES is used, carry out the following operations in addition to the routine maintenance:

- After the first 50 hours of operation, change the hydraulic circuit drain filter.
- After the first 500 hours of operation, change the hydraulic circuit oil.

IMPORTANT

- **When changing the oil filters (cartridges), check their inner part to make sure that there are no deposits. If considerable deposits can be observed, find out what may have caused them before restarting the machine.**
- **The number of operating hours is indicated by the hour meter.**

1.4 PRODUCT IDENTIFICATION

The Komatsu COMPACT LOADER and its main components are identified by serial numbers stamped on the identification plates.

The serial number and the identification numbers of the components are the only numbers that must always be indicated to the Dealer when requiring assistance and ordering spare parts.

1.4.1 MACHINE SERIAL NUMBER

The machine serial number is stamped on the inner wall of the rear right pillar.

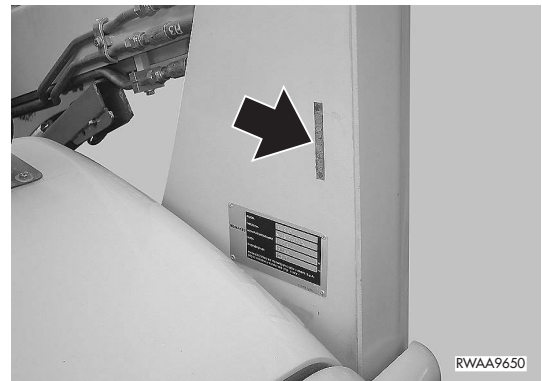

1.4.2 MACHINE IDENTIFICATION PLATE AND PRODUCT IDENTIFICATION NUMBER (PIN)

The Komatsu MACHINES described in this manual are provided with the CE mark, which certifies that they are in compliance with the CE harmonized standards.

The plate with the mark is applied on to the inner wall of the rear right pillar.

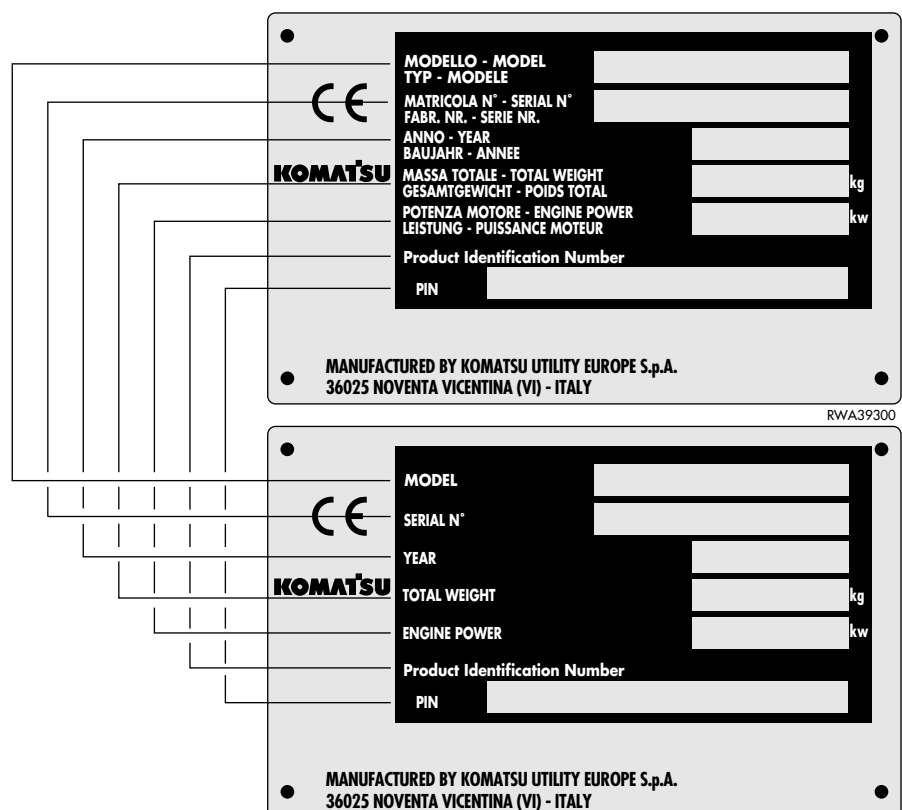
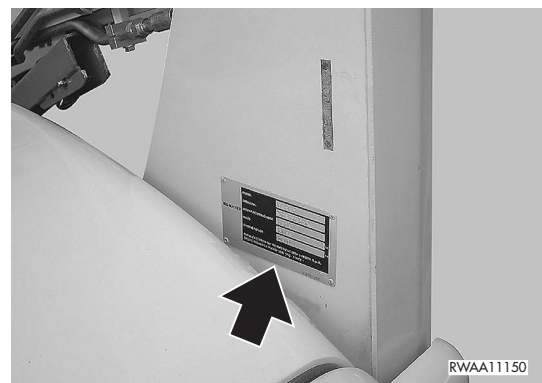

1.4.3 ENGINE SERIAL NUMBER AND EXHAUST GAS EMISSION PLATE

The plate (1) indicating the engine serial number and the exhaust gas emission plate are positioned on the upper side of the tappet cover.

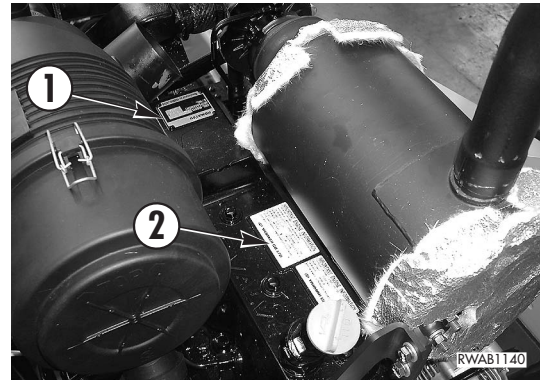

1.4.4 TRAVEL REDUCTION GEAR SERIAL NUMBER

The serial number of the travel reduction gear is stamped on the plate positioned on the hydraulic motor cover.

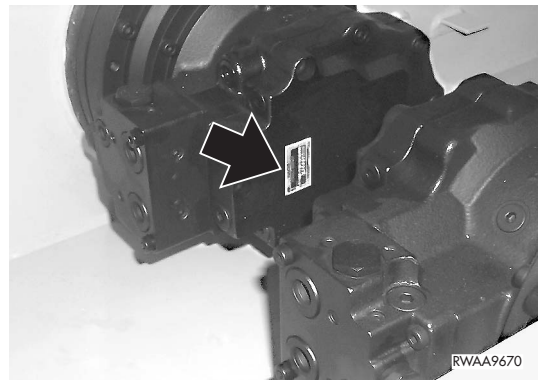

1.4.5 CAB SERIAL NUMBER

The cab serial number is stamped on the plate positioned on the right side of the base cross member.



1.4.6 EXCAVATOR IDENTIFICATION PLATE (if installed)

The excavator identification number is stamped on the plate positioned on the left side of the control panel.



1.4.7 SERIAL NUMBERS AND DEALER'S ADDRESS

Machine N° _____ Model _____

Engine N° _____

Product identification number (PIN) _____

Travel reduction gear N° _____

Cab N° _____

Excavator (if installed) N° _____

Dealer:

Address: _____

_____ Tel. _____

Person to contact: _____

NOTES: _____

TABLE OF CONTENTS

FOREWORD

1.1	FOREWORD	1
1.2	INFORMATION ON SAFETY	2
1.3	INTRODUCTION	4
1.3.1	INTENDED USES	4
1.3.2	IMPROPER OR UNAUTHORIZED USES.....	4
1.3.3	MAIN CHARACTERISTICS.....	4
1.3.4	RUNNING-IN	5
1.4	PRODUCT IDENTIFICATION	6
1.4.1	MACHINE SERIAL NUMBER.....	6
1.4.2	MACHINE IDENTIFICATION PLATE AND PRODUCT IDENTIFICATION NUMBER (PIN) ...	6
1.4.3	ENGINE SERIAL NUMBER AND EXHAUST GAS EMISSION PLATE	7
1.4.4	TRAVEL REDUCTION GEAR SERIAL NUMBER	7
1.4.5	CAB SERIAL NUMBER	7
1.4.6	EXCAVATOR IDENTIFICATION PLATE (if installed)	7
1.4.7	SERIAL NUMBERS AND DEALER'S ADDRESS	8

SAFETY AND ACCIDENT PREVENTION

2.1	SAFETY, NOISE AND VIBRATION PLATES	16
2.1.1	POSITION OF THE SAFETY PLATES	16
2.1.1.1	SAFETY PLATES	16
2.1.1.2	SAFETY PLATES FOR MACHINES WITH EXCAVATOR	18
2.1.2	PICTOGRAMS AND RELEVANT MEANINGS.....	20
2.1.3	POSITION OF THE NOISE PLATES	23
2.1.4	VIBRATIONS TO WHICH THE OPERATOR IS SUBJECTED	23
2.2	GENERAL PRECAUTIONS	24
2.2.1	GENERAL SAFETY RULES	24
2.2.2	SAFETY DEVICES AND GUARDS.....	24
2.2.3	CLOTHING AND PERSONAL PROTECTION ITEMS	24
2.2.4	UNAUTHORIZED MODIFICATIONS	25
2.2.5	LEAVING THE OPERATORS SEAT	25
2.2.6	GETTING ON AND OFF THE MACHINE	26
2.2.7	CHECKING THE REAR-VIEW MIRRORS (if installed)	26
2.2.8	PREVENTING FIRES DUE TO FUEL AND OIL	27
2.2.9	PREVENTING BURNS	27
2.2.10	PREVENTING DAMAGE DUE TO ASBESTOS POWDER	28
2.2.11	PREVENTING DAMAGE CAUSED BY THE WORK EQUIPMENT	28
2.2.12	FIRE EXTINGUISHERS AND FIRST AID KIT	29
2.2.13	PRECAUTIONS CONCERNING THE CAB STRUCTURE	29
2.2.14	PRECAUTIONS CONCERNING THE EQUIPMENT	29
2.3	PRECAUTIONS TO BE TAKEN BEFORE STARTING THE ENGINE	30
2.3.1	SAFETY ON THE WORK SITE	30
2.3.2	FIRE PREVENTION	30
2.3.3	PRECAUTIONS TO BE TAKEN FOR THE OPERATOR'S CAB	30
2.3.4	ROOM VENTILATION	31
2.3.5	PRECAUTIONS TO BE TAKEN FOR THE LIGHTS (if installed).....	31
2.3.6	CLEANING THE WINDOWS AND THE REAR-VIEW MIRRORS - CHECKING THE WINDSHIELD WIPER BLADES (if installed)	31

TABLE OF CONTENTS

2.4	PRECAUTIONS TO BE TAKEN WHEN WORKING	32
2.4.1	STARTING THE ENGINE.....	32
2.4.2	RULES TO BE FOLLOWED WHEN TRAVELLING ON ROADS	32
2.4.3	CHECKS FOR TRAVELLING IN REVERSE	33
2.4.4	MOVING THE MACHINE	34
2.4.5	WORKING ON SLOPES	34
2.4.6	PREVENTING ELECTROCUTION.....	36
2.4.7	VISIBILITY	37
2.4.8	WORKING ON ICY OR SNOW-COVERED SURFACES.....	37
2.4.9	PREVENTING DAMAGE CAUSED BY THE WORK EQUIPMENT	37
2.4.10	WORKING ON LOOSE GROUND	37
2.4.11	PARKING THE MACHINE	38
2.5	TRANSPORTING THE MACHINE ON OTHER VEHICLES	39
2.5.1	LOADING AND UNLOADING THE MACHINE	39
2.5.2	THE ROUTE	39
2.6	BATTERY	40
2.6.1	SAFETY PRECAUTIONS FOR WORK ON BATTERIES	40
2.6.2	STARTING WITH BOOSTER CABLES	40
2.7	PRECAUTIONS FOR EMERGENCY RECOVERY	41
2.8	PRECAUTIONS TO BE TAKEN DURING MAINTENANCE	43
2.8.1	WARNING PLATES	43
2.8.2	TOOLS	43
2.8.3	PERSONNEL.....	44
2.8.4	EQUIPMENT	44
2.8.5	WORKING UNDER THE MACHINE	44
2.8.6	KEEPING THE MACHINE CLEAN	44
2.8.7	USE OF THE ENGINE DURING MAINTENANCE	45
2.8.8	PERIODICAL CHANGE OF THE PARTS THAT ARE CRITICAL FOR SAFETY.....	45
2.8.9	STOP THE ENGINE BEFORE CARRYING OUT ANY MAINTENANCE OPERATION OR INSPECTION	45
2.8.10	RULES FOR REFUELLING AND ADDING OIL	46
2.8.11	CHECKING THE COOLANT LEVEL IN THE RADIATOR	46
2.8.12	USING LAMPS	46
2.8.13	PRECAUTIONS CONCERNING THE BATTERY AND THE ALTERNATOR	47
2.8.14	PRECAUTIONS CONCERNING THE STARTER	47
2.8.15	PRECAUTIONS CONCERNING HIGH-PRESSURE HOSES.....	48
2.8.16	PRECAUTIONS TO BE TAKEN WHEN WORKING ON HIGH-PRESSURE SYSTEMS	48
2.8.17	PRECAUTIONS FOR MAINTENANCE WORK INVOLVING HIGH TEMPERATURES AND PRESSURES	48
2.8.18	COOLING FAN AND FAN BELT	49
2.8.19	WASTE MATERIALS	49
2.8.20	PRECAUTIONS TO BE TAKEN WHEN INFLATING THE TYRES	49
2.8.21	PRECAUTIONS TO BE TAKEN WHEN USING THE SYNTHETIC BIODEGRADABLE OIL TYPE «HEES».....	50

DESCRIPTION AND USE OF THE MACHINE

3.1	SAFETY LOCKS	52
3.1.1	LOADER LOCKS	52
3.1.2	EXCAVATOR LOCKS (if installed)	54
3.1.3	ASPHALT CUTTER LOCKS (if installed)	56
3.2	GENERAL VIEWS	57
3.2.1	FRONT GENERAL VIEW	57
3.2.2	REAR GENERAL VIEW	58
3.2.3	CAB INSIDE GENERAL VIEW	59
3.3	INSTRUMENTS AND CONTROLS	61
3.3.1	INSTRUMENTS.....	61
3.3.2	WARNING LIGHTS	63
3.3.3	SWITCHES UND PUSH BUTTONS.....	68
3.3.4	ELECTRICAL ACCESSORIES	74
3.3.5	MACHINE CONTROLS	76
3.4	FUSES AND RELAYS	96
3.4.1	MACHINE FUNCTION FUSES	96
3.4.2	MAIN FUSE	97
3.4.3	RELAYS	98
3.5	GUARDS AND DRIVER'S SEAT	100
3.5.1	ENGINE HOOD	100
3.5.2	REAR PANEL	101
3.5.3	CAB	102
3.5.3.1	STANDARD CAB	102
3.5.3.2	CAB WITH FRONT DOOR AND SIDE WINDOWS (available on request).....	102
3.5.3.3	WINDSHIELD DETERGENT RESERVOIR (only for cab with front door)	104
3.5.3.4	RAISING THE CAB	105
3.5.4	STANDARD SEAT	107
3.5.5	CUSHIONED SEAT	107
3.5.6	SAFETY BELT.....	108
3.5.7	EMERGENCY EXIT	108
3.5.8	TECHNICAL DOCUMENTATION CASE.....	109
3.5.9	FIRE EXTINGUISHER	109
3.5.10	FIRST AID KIT	109
3.6	USE OF THE MACHINE	110
3.6.1	CHECKS BEFORE STARTING THE ENGINE.....	110
3.6.1.1	VISUAL CHECKS.....	110
3.6.1.2	DAILY CHECKS.....	110
3.6.1.3	OPERATIONAL CHECKS	111
3.6.2	STARTING THE ENGINE	112
3.6.2.1	STARTING WITH WARM ENGINE OR IN TEMPERATE CLIMATES	112
3.6.2.2	STARTING WITH COLD ENGINE OR IN COLD CLIMATES	113
3.6.3	WARMING THE ENGINE.....	114
3.6.4	HEATING THE HYDRAULIC OIL.....	114
3.6.5	HOW TO MOVE THE MACHINE (ISO PATTERN CONTROL SYSTEMERN)	114
3.6.5.1	STEERING (CHANGING DIRECTION)	116
3.6.6	HOW TO MOVE THE MACHINE (OPTIONAL PATTERN CONTROL SYSTEM).....	118
3.6.6.1	STEERING (CHANGING DIRECTION)	120
3.6.7	MOVING ON SLOPES	122
3.6.8	MAXIMUM IMMERSION DEPTH	123

TABLE OF CONTENTS

3.7	PARKING THE MACHINE	124
3.7.1	PARKING ON LEVEL GROUND	124
3.7.2	PARKING ON SLOPES.....	125
3.8	STOPPING THE ENGINE	126
3.9	TRANSPORTING THE MACHINE ON OTHER VEHICLES	127
3.9.1	LOADING AND UNLOADING THE MACHINE.....	127
3.9.2	TRANSPORT.....	128
3.10	HOW TO LIFT THE MACHINE	129
3.11	PRECAUTIONS TO BE TAKEN IN THE COLD SEASON	130
3.11.1	FUEL AND LUBRICANTS	130
3.11.2	COOLANT	130
3.11.3	BATTERY	131
3.11.4	OTHER PRECAUTIONS	131
3.11.5	PRECAUTIONS TO BE TAKEN AT THE END OF WORK	131
3.12	PRECAUTIONS TO BE TAKEN IN THE WARM SEASON	132
3.13	USING THE WORK EQUIPMENT	133
3.13.1	LOWERING THE EQUIPMENT IN CASE OF MACHINE FAILURE	133
3.13.2	ORGANIZING THE WORK ARE	134
3.13.3	LOADING MATERIAL ON HEAPS AND ON LEVEL SURFACES	135
3.13.4	LOADING MATERIAL ON SLOPES	136
3.13.5	DIGGING METHOD.....	137
3.13.6	CHANGING THE BUCKET OR THE EQUIPMENT WITH STANDARD RAPID COUPLING ...	138
3.13.6.1	REMOVING THE BUCKET OR THE EQUIPMENT	139
3.13.6.2	CONNECTING THE BUCKET	140
3.13.6.3	CHECKING THE POSITION OF THE LOCKING PINS	141
3.13.6.4	ADJUSTING THE LOCKING PINS	142
3.14	LONG PERIODS OF INACTIVITY	143
3.14.1	BEFORE THE PERIOD OF INACTIVITY	143
3.14.2	DURING THE PERIOD OF INACTIVITY	144
3.14.3	AFTER THE PERIOD OF INACTIVITY	144
3.15	TROUBLESHOOTING	145
3.15.1	HOW TO REMOVE THE MACHINE.....	145
3.15.2	IF THE FUEL HAS BEEN COMPLETELY DEPLETED.....	145
3.15.3	IF THE BATTERY IS DEPLETED	146
3.15.3.1	STARTING WITH BOOSTER CABLES	147
3.15.4	OTHER TROUBLES.....	148
3.15.4.1	ELECTRICAL CIRCUIT.....	148
3.15.4.2	HYDRAULIC SYSTEM.....	148
3.15.4.3	ENGINE.....	149
3.15.4.4	HYDROSTATIC TRANSMISSION	150

MAINTENANCE

4.1	GUIDE TO MAINTENANCE	154
4.2	MAINTENANCE NOTES	156
4.2.1	NOTES REGARDING THE ENGINE	156
4.2.1.1	ENGINE OIL	156
4.2.1.2	COOLANT	156
4.2.1.3	FUEL	157
4.2.2	NOTES REGARDING THE HYDRAULIC SYSTEM	157
4.2.3	NOTES REGARDING THE ELECTRICAL SYSTEM	157
4.2.4	NOTES REGARDING LUBRICATION	158
4.2.5	PARTS SUBJECT TO WEAR THAT PERIODICALLY NEED CHANGING	158
4.3	FUEL, COOLANT AND LUBRICANTS	159
4.3.1	HOMOLOGATED SYNTHETIC BIODEGRADABLE LUBRICANTS TYPE HEES	161
4.4	DRIVING TORQUES FOR SCREWS AND NUTS	162
4.4.1	STANDARD DRIVING TORQUES	162
4.4.2	SPECIFIC DRIVING TORQUES	162
4.5	LUBRICATION	163
4.5.1	LUBRICATION DIAGRAM	163
4.6	PERIODICAL CHANGE OF THE COMPONENTS CONNECTED WITH SAFETY	164
4.6.1	CRITICAL PARTS FOR SAFETY	165
4.7	MAINTENANCE PLAN	171
4.8	MAINTENANCE PROCEDURE	173
4.8.1	WHEN REQUIRED	173
4.8.1.a	CHECKING, CLEANING OR CHANGING THE AIR CLEANER CARTRIDGE	173
4.8.1.b	TYRE ROTATION	174
4.8.1.c	DRAINING THE FUEL TANK	175
4.8.1.d	RELEASING THE PARKING BRAKE	176
4.8.1.e	CHECKING THE BATTERY CHARGE LEVEL	177
4.8.2	CHECKS BEFORE STARTING	178
4.8.2.a	VARIOUS CHECKS	178
4.8.2.b	CHECKING THE COOLANT LEVEL	178
4.8.2.c	CHECKING THE FUEL LEVEL	179
4.8.2.d	CHECKING THE ENGINE OIL LEVEL	180
4.8.2.e	CHECKING THE OIL LEVEL IN THE HYDRAULIC CIRCUIT	181
4.8.2.f	CHECKING THE WATER SEPARATOR FOR SEDIMENTS AND WATER	182
4.8.2.g	CHECKING THE WIRING SYSTEM	182
4.8.3	MAINTENANCE AFTER THE FIRST 50 HOURS OF OPERATION	183
4.8.4	MAINTENANCE EVERY 50 HOURS OF OPERATION	183
4.8.4.a	CHECKING THE TYRE PRESSURE	183
4.8.4.b	CHECKING THE COOLANT LEVEL IN THE RADIATOR	183
4.8.5	MAINTENANCE AFTER THE FIRST 250 HOURS OF OPERATION	184
4.8.6	MAINTENANCE EVERY 250 HOURS OF OPERATION	184
4.8.6.a	ADJUSTING THE FAN BELT TENSION	184
4.8.6.b	CHECKING THE GEARING CHAIN TENSION	185
4.8.6.c	CLEANING THE OUTSIDE OF THE RADIATORS	187
4.8.6.d	CHECKING THE WHEEL NUT DRIVING TORQUE	187
4.8.6.e	CHECKING THE OIL LEVEL IN THE FINAL TRANSMISSIONS	188
4.8.6.f	LUBRICATING THE JOINTS	189
4.8.6.g	CHANGING THE ENGINE OIL	190
4.8.6.h	CHANGING THE ENGINE OIL FILTER	191
4.8.7	MAINTENANCE AFTER THE FIRST 500 HOURS OF OPERATION (Only for machines filled with synthetic biodegradable oil type HEES)	192

TABLE OF CONTENTS

4.8.8	MAINTENANCE EVERY 500 HOURS OF OPERATION	192
4.8.8.a	CHANGING THE FUEL FILTER	192
4.8.8.b	CHANGING THE HYDRAULIC OIL DRAIN FILTER	194
4.8.8.c	CLEANING THE WATER SEPARATOR.....	195
4.8.8.d	DRAINING THE HYDRAULIC OIL TANK (Only for machines filled with synthetic biodegradable oil type HEES)	196
4.8.9	MAINTENANCE EVERY 1000 HOURS OF OPERATION	197
4.8.9.a	CHANGING THE OIL IN THE FINAL TRANSMISSION	197
4.8.9.b	CHANGING THE HYDRAULIC SYSTEM OIL AND CLEANING THE SUCTION FILTER.....	198
4.8.9.c	CHECKING AND ADJUSTING THE ENGINE VALVE CLEARANCE	199
4.8.10	MANUTENZIONE OGNI 2000 ORE	200
4.8.10.a	CHANGING THE COOLANT	200
4.8.10.b	CHANGING THE SUCTION FILTER	201
4.8.10.c	CHECKING THE ALTERNATOR AND THE STARTER	202

TECHNICAL SPECIFICATIONS

5.1	TECHNICAL DATA	204
5.1.1	STANDARD MACHINE OVERALL DIMENSIONS	204
5.1.2	MACHINE OVERALL DIMENSIONS WITH OPTIONAL EQUIPMENT	205
5.1.3	TECHNICAL CHARACTERISTICS	206

AUTHORIZED OPTIONAL EQUIPMENT

6.1	AUTHORIZED OPTIONAL EQUIPMENT	208
6.1.1	PRECAUTIONS REGARDING SAFETY	208
6.1.2	PRECAUTIONS REGARDING THE INSTALLATION OF EQUIPMENT	209
6.1.3	CHARACTERISTICS OF THE STANDARD MACHINE OPTIONAL EQUIPMENT.....	210
6.1.4	CHARACTERISTICS OF THE OPTIONAL EQUIPMENT OF THE MACHINE VERSION WITH HIGH FLOW AND SUPER-FLOW HYDRAULIC SYSTEM	211
6.2	CHANGING THE AUTHORIZED EQUIPMENT	212
6.2.1	CONNECTING THE EXCAVATOR	212
6.2.2	CONNECTING THE HYDRAULIC CIRCUIT	213
6.2.3	CONNECTING THE RETURN CIRCUIT WITH DIRECT DRAINAGE INTO THE TANK	215
6.2.4	PREPARING THE MACHINE FOR THE USE OF THE EXCAVATOR	216
6.2.5	USING THE MACHINE WITH THE EXCAVATOR	216
6.3	PALLET FORKS	217
6.4	CHANGING THE OPERATING PATTERN	218
6.4.1	HOW TO CHANGE THE OPERATING PATTERN	220
6.5	HAND & FOOT CONTROL SYSTEM	221
6.5.1	MACHINE CONTROLS	221
6.5.1.1	TRAVEL AND STEERING CONTROL LEVERS.....	222
6.5.1.2	WORK EQUIPMENT CONTROL PEDALS (LOADER ARM AND BUCKET).....	224
6.5.1.3	AUXILIARY HYDRAULIC KIT CONTROL.....	227
6.5.2	HOW TO MOVE THE MACHINE (HAND & FOOT CONTROL SYSTEM)	230
6.5.2.1	STEERING (CHANGING DIRECTION)	232

SAFETY AND ACCIDENT PREVENTION

2.1 SAFETY, NOISE AND VIBRATION PLATES

2.1.1 POSITION OF THE SAFETY PLATES

- The safety plates must always be legible and in good conditions; for this reason, if they are dirty with dust, oil or grease, it is necessary to clean them with a solution made of water and detergent. Do not use fuel, petrol or solvents.
- If the plates are damaged, ask for new ones to Komatsu or to your Komatsu Dealer.
- In case of replacement of a component provided with a safety plate, make sure that this plate is applied also on the new part.
- The machine can be provided with other plates in addition to those indicated below; in any case, keep also to the instructions given in the additional plates.

2.1.1.1 SAFETY PLATES

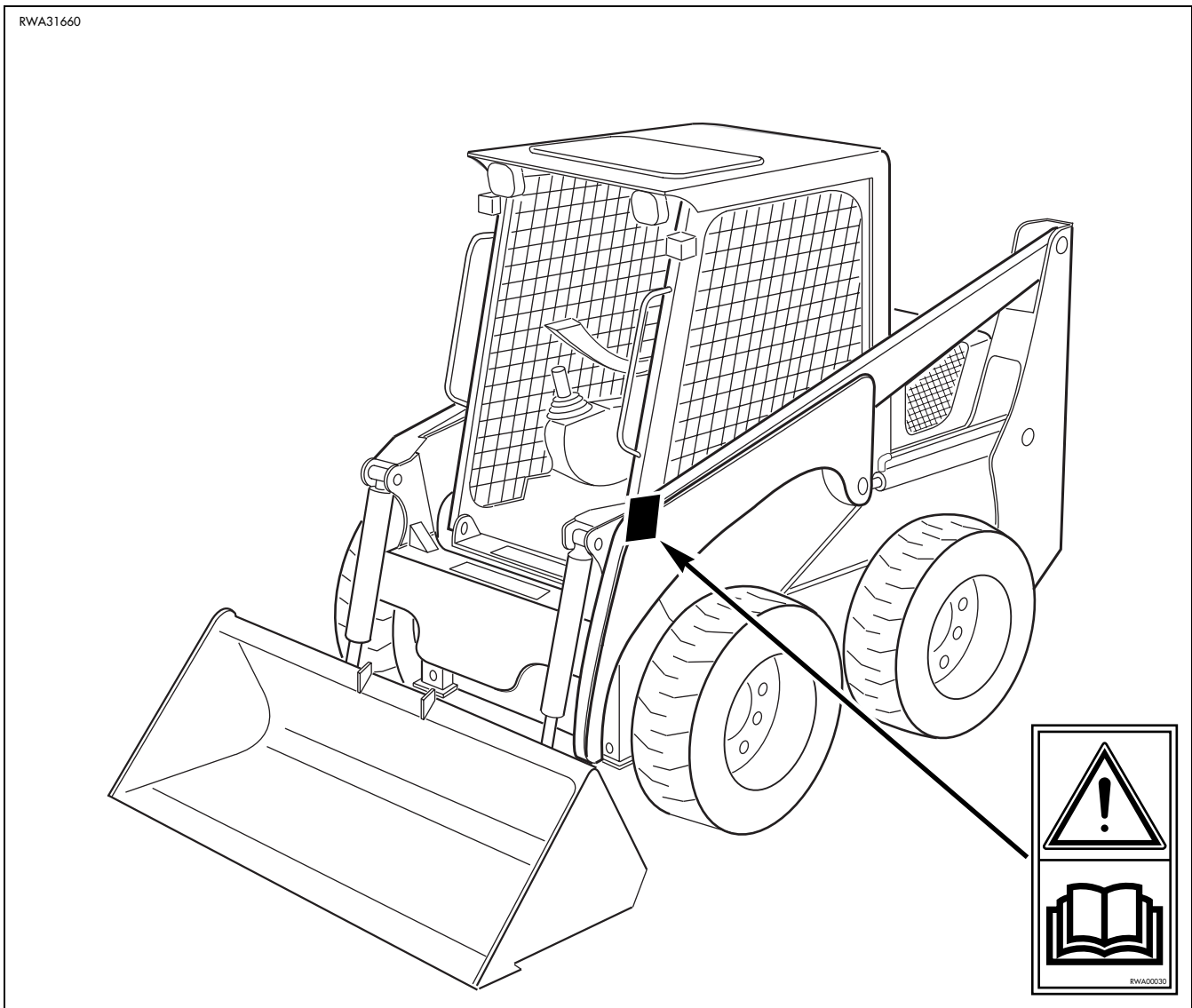

RWA31670

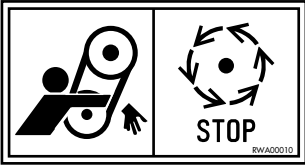
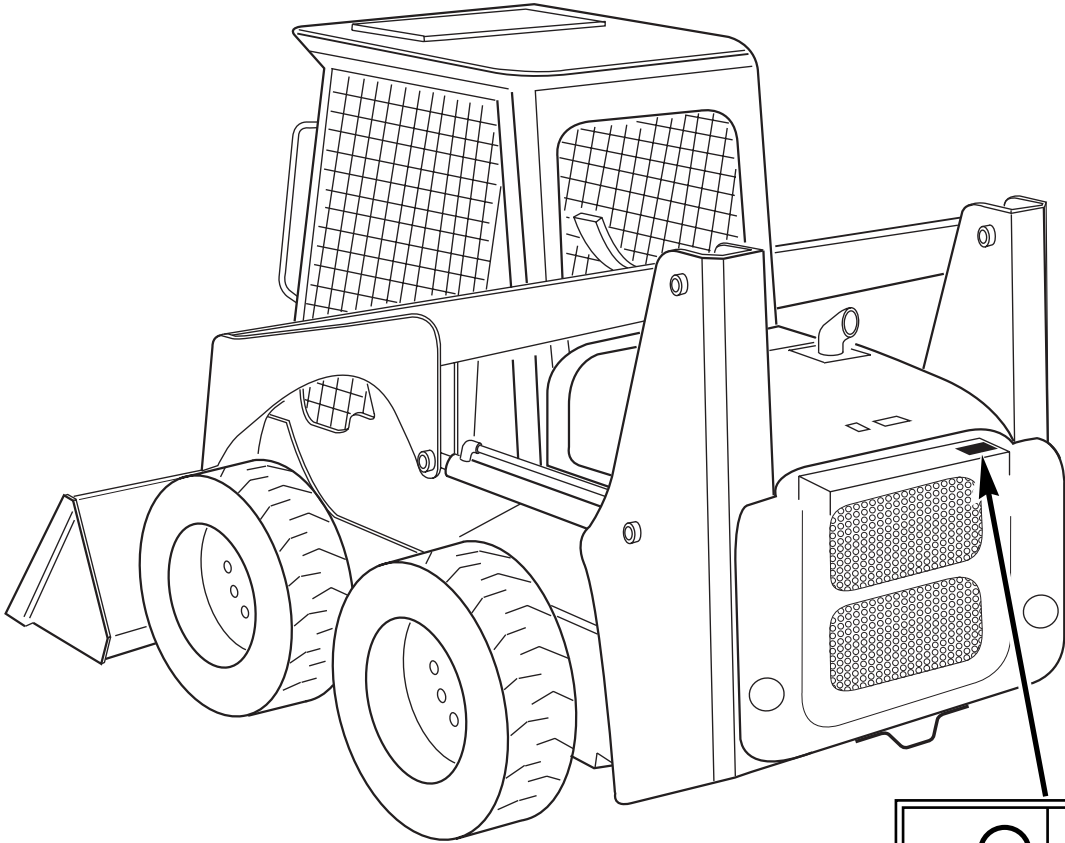

SAFETY, NOISE AND VIBRATION PLATES

2.1.1.2 SAFETY PLATES FOR MACHINES WITH EXCAVATOR

