

SHOP MANUAL

KOMATSU

HD1200M-1

MACHINE MODEL SERIAL No.

HD1200M-1 1002 and up

LIST OF REVISED PAGES

LIST OF REVISED PAGES

The affected pages are indicated by the use of the following marks. It is requested that necessary actions be taken to these pages according to the table below.

Mark	Indication	Action required
○	Page to be newly added	Add
●	Page to be replaced	Replace
()	Page to be deleted	Discard

Pages having no marks are those previously revised or made additions.

LIST OF REVISED PAGES

Mark	Page	Time of revision	Mark	Page	Time of revision	Mark	Page	Time of revision	Mark	Page	Time of revision	Mark	Page	Time of revision
●	00- 1	⑨		01- 1			03- 7	③		12-12			13-26	
●	00- 2	⑨		01- 3	②		03- 8	③		12-13			13-27	③
●	00- 2-1	⑨		01- 4	②		03- 9	③		12-14				
●	00- 2-2	⑨		01- 5	②		03-10	⑤		12-15	③		16- 1	①
●	00- 2-3	⑨		01- 5-1	②		03-10-1	⑤					16- 3	①
●	00- 2-4	⑨		01- 5-2	②		03-11	③		13- 1			16- 4	①
●	00- 2-5	⑨		01- 6	②		03-12	③		13- 3			16- 5	①
	00- 3			01- 7	②		03-13			13- 4	③		16- 6	①
	00- 4			01- 8			03-14			13- 5			16- 7	①
	00- 5			01- 9	②		03-15	③		13- 6	③		16- 8	①
	00- 6						03-16	③		13- 7	③		16- 9	①
	00- 7						03-17	③		13- 8	③		16-10	①
	00- 8			02- 1			03-18	③		13- 9	③		16-11	①
	00- 9			02- 3			03-19	③		13-10			16-12	①
	00-10			02- 4	③		03-20	③		13-11			16-13	①
	00-11			02- 5			03-21	③		13-12	⑤			
	00-12			02- 6	③		03-22	③		13-13	③			
	00-13			02- 7	⑤					13-14	⑤		21- 1	
	00-14			02- 8	③		12- 1			13-15			21- 3	⑦
	00-15			02- 9			12- 3			13-16	③		21- 4	④
	00-16			02-10			12- 4	①		13-18			21- 5	⑤
	00-17						12- 5			13-19			21- 6	②
	00-18						12- 6	③		13-20	③		21- 6-1	②
	00-19			03- 1			12- 7			13-21	⑤		21- 7	
	00-20			03- 3			12- 8			13-22	⑤		21- 8	
	00-21			03- 4	③		12- 9			13-23			21- 9	
	00-22			03- 5	③		12-10			13-24	⑤		21-10	②
				03- 6			12-11	⑤		13-25			21-11	②

LIST OF REVISED PAGES

LIST OF REVISED PAGES

Mark	Page	Time of revision	Mark	Page	Time of revision	Mark	Page	Time of revision	Mark	Page	Time of revision	Mark	Page	Time of revision
	21-11-1	⑦		21-38	②		22- 5	⑤		23-24			23-65	
	21-11-2	⑦		21-38-1	⑧		22- 6	③		23-25			23-66	
•	21-11-3	⑨		21-38-2	⑦		22- 7	③		23-26	③		23-67	
•	21-11-4	⑨		21-38-3	④		22- 8	④		23-27			23-68	
•	21-11-5	⑨		21-38-4	④		22- 9	③		23-28			23-69	⑥
•	21-11-6	⑨		21-38-5	④		22-10	⑤		23-29			23-70	
	21-11-7	⑦		21-38-6	⑧		22-10-1	⑤		23-30	③		23-71	
	21-11-8	⑦		21-38-7	⑧		22-10-2	⑤		23-31			23-72	⑥
	21-12	⑦	•	21-38-8	⑨		22-11	③		23-32	③		23-73	⑥
	21-13	⑦	•	21-38-9	⑨		22-501			23-33	③		23-74	⑥
	21-13-1	⑦		21-39	②		22-502			23-34	③		23-75	⑥
•	21-13-2	⑨		21-40			22-504			23-36			23-76	⑥
○	21-13-3	⑨		21-41	②		22-505			23-37	③		23-77	⑥
○	21-13-4	⑨		21-41-1	②		22-506			23-38	③		23-78	⑥
○	21-14	⑨		21-41-2	⑤		22-507			23-39	③		23-79	
	21-16			21-42	②		22-508			23-40			23-80	⑥
	21-17	②		21-43	⑦		22-509			23-41			23-81	
	21-18			21-43-1	②					23-42			23-82	⑤
	21-19			21-43-2	②		23- 1			23-43			23-83	③
	21-20			21-44	②		23- 3			23-44			23-84	⑤
	21-21			21-44-1	②		23- 4			23-45			23-85	⑤
	21-22			21-45	②		23- 5	③		23-46	③		23-86	
	21-23			21-46			23- 6	③		23-47			23-87	⑤
	21-24			21-48	②		23- 7	③		23-48	③		23-88	
	21-25			21-48-1	②		23- 8			23-48-1	③		23-89	
	21-26			21-48-2	②		23- 9			23-48-2	③		23-90	
	21-27	①		21-48-3	②		23-10			23-49	③		23-91	③
	21-28	⑦		21-48-4	②		23-11	③		23-50			23-92	③
	21-29	⑦		21-48-5	②		23-12	③		23-51			23-93	⑤
	21-29-1	⑦		21-49	③		23-13	③		23-52			23-94	
	21-29-2	⑦		21-50			23-14	③		23-53	③		23-95	
	21-30	⑦		21-51	⑤		23-15	⑤		23-56			23-96	
	21-31	⑦		21-52	⑤		23-16	③		23-57			23-97	
	21-32			21-53	⑤		23-17			23-58			23-98	
	21-33	①					23-18	③		23-59			23-99	
	21-34	①					23-19	③		23-60			23-100	
	21-34-1	①					23-20	⑤		23-61			23-100-1	③
	21-35			22- 1			23-21	③		23-62			23-100-2	③
	21-36			22- 3			23-22	③		23-63			23-100-3	③
	21-37			22- 4	⑤		23-23	③		23-64			23-101	③

LIST OF REVISED PAGES

LIST OF REVISED PAGES

Mark	Page	Time of revision	Mark	Page	Time of revision	Mark	Page	Time of revision	Mark	Page	Time of revision	Mark	Page	Time of revision
	23-102			23-131-1	⑤		41- 1			42-507			51- 1	
	23-102-1	③		23-132	③		41- 3			42-508			51- 3	⑦
	23-102-2	③		23-133	③		41- 4			42-509			51- 4	
	23-102-3	③					41- 5			43- 1			51- 5	
	23-103	③					41- 6			43- 3	③		51- 6	
	23-104			24- 1			41- 7			43- 4	④		51- 7	
•	23-105	⑨		24- 3			41- 8			43- 5	④		51- 8	②
	23-106	①		24- 5	⑤		41- 9	②		43- 6	④		51- 9	
	23-107	①		24- 6			41-10	②		43- 7			51- 9- 1	③
	23-108	③		24- 7	③		41-11	②		43- 8			51- 9- 2	②
	23-108-1	③		24- 8	③		41-13			43- 9			51- 9- 3	⑤
	23-108-2	③		24- 9			41-14			43-10			51- 9- 4	③
	23-108-3	③		24-10	⑦		41-15			43-11			51- 9- 5	⑦
	23-108-4	③	•	24-11	⑨		41-16			43-12			51- 9- 6	⑤
	23-108-5	⑤	•	24-11-1	⑨		41-17			43-13			51- 9- 7	⑧
	23-109		○	24-11-2	⑨					43-14			51- 9- 8	⑦
	23-110		○	24-11-3	⑨					43-15			51- 9- 9	⑧
	23-111			24-12			42- 1			43-16			51- 9-10	⑧
	23-112			24-13			42- 3			43-17			51-10	②
	23-113			24-14			42- 4	③		43-18			51-11	②
	23-114			24-15	⑧		42- 4-1	③		43-19			51-11-1	③
	23-115			24-16	⑧		42- 5			43-20			51-11-2	②
	23-116			24-17	⑧		42- 6			43-21			51-11-3	③
	23-117			24-18			42- 7			43-22			51-11-4	③
	23-118			24-19			42- 8			43-24			51-12	⑤
	23-119			24-20			42- 9			43-25			51-12-1	⑧
	23-119-1	⑤		24-21			42-10	①		43-26			51-12-2	⑧
	23-119-2	⑤		24-22	③		42-11			43-27			51-13	②
	23-120			24-23			42-12	③		43-28			51-14	②
	23-121			24-24	③		42-13	③		43-29	③		51-15	②
	23-122			24-25	③		42-14						51-16	②
	23-123			24-26	③		42-15						51-17	②
	23-124			24-27						44- 1			51-18	②
	23-125			24-27-1	③					44- 3			51-19	②
	23-126			24-27-2	③		42-501			44- 4			51-19-1	③
	23-127			24-27-3	③		42-502	③		44- 5	⑤		51-19-2	③
	23-128			24-28			42-503	③		44- 6	③		51-19-3	③
	23-129			24-29	⑤		42-504	③		44- 7			51-19-4	③
	23-130	⑤		24-30	⑤		42-505			44- 8			51-19-5	③
	23-131	⑤					42-506			44- 9			51-19-6	③

LIST OF REVISED PAGES

LIST OF REVISED PAGES

Mark	Page	Time of revision	Mark	Page	Time of revision	Mark	Page	Time of revision	Mark	Page	Time of revision	Mark	Page	Time of revision
	51-19-7	⑤		51-34-3	⑦		51-67	②		54- 8	⑦		61-16-8	②
	51-19-8	⑤		51-34-4	⑦		51-68	②					61-17	②
	51-19-9	⑤		51-34-5	⑦		51-69	⑧					61-18	②
	51-19-10	⑤		51-35	⑦		51-70	②		61- 1			61-18-1	③
	51-19-11	⑤		51-36						61- 3			61-18-2	②
	51-19-12	⑤		51-37						61- 4	②		61-18-3	③
	51-19-13	⑦		51-38	②		53- 1			61- 5	②		61-18-4	③
	51-19-14	⑦		51-38-1	⑦		53- 3			61- 6	②		61-18-5	③
	51-19-15	⑦		51-38-2	⑦		53- 4	③		61- 7	②		61-19	
	51-19-16	⑦		51-38-3	⑦		53- 5	③		61- 7-1	②		61-20	
	51-19-17	⑦		51-39			53- 6	③		61- 7-2	②		61-21	
	51-19-18	⑦		51-40			53- 7			61- 7-3	⑧		61-22	③
	51-19-19	⑦		51-42			53- 8			61- 7-3-1	⑧		61-23	②
	51-19-20	⑦		51-43			53- 9	③		61- 7-4	②		61-24	②
	51-19-21	⑦		51-44			53-10			61- 7-5	⑤		61-24-1	③
	51-19-22	⑦		51-44-1	②		53-11			61- 7-6	⑧		61-24-2	③
	51-19-23	⑦		51-44-2	②		53-11-1	③		61- 7-7	⑧		61-24-3	②
	51-19-24	⑧		51-44-3	②		53-11-2	③		61- 8	②		61-25	
	51-20	②		51-45			53-12			61- 9	②			
	51-20-1	③		51-46			53-14			61-10	②			
	51-20-2	⑤		51-47	⑧		53-15			61-11	②		62- 1	
	51-20-3	⑦		51-49			53-16			61-12	②		62- 3	
	51-20-4	⑧		51-50	②		53-17			61-12-1	③		62- 4	③
	51-20-5	⑧		51-51			53-18			61-12-2	②		62- 5	
	51-21	⑤		51-52			53-19			61-12-3	②		62- 6	③
	51-22	②		51-53			53-20	③		61-12-4	②		62- 7	③
	51-22-1	②		51-54			53-21			61-12-5	③		62-501	
	51-26			51-55			53-22	③		61-12-6	②		62-502	③
	51-27			51-56	②		53-23	⑤		61-12-7	②		62-503	③
	51-28			51-56-1	⑤		53-24	⑤		61-12-8	②		62-504	③
	51-29			51-56-2	②		53-25	⑤		61-13	②			
	51-30			51-56-3	②		53-26	⑤		61-14	②			
	51-31			51-57						61-15			63- 1	
	51-32	②		51-58						61-16	①		63- 3	③
	51-33			51-59			54- 1			61-16-2	③		63- 4	③
	51-33-1	②		51-60			54- 3	③		61-16-3	②		63- 5	④
	51-33-2	⑤		51-61			54- 4	③		61-16-4	③		63- 6	③
	51-34	②		51-64			54- 5	③		61-16-5	②		63- 7	③
	51-34-1	⑦		51-65			54- 6	③		61-16-6	②		63- 8	
	51-34-2	③		51-66	②		54- 7	⑦		61-16-7	②		63- 9	

LIST OF REVISED PAGES

LIST OF REVISED PAGES

Mark	Page	Time of revision	Mark	Page	Time of revision	Mark	Page	Time of revision	Mark	Page	Time of revision	Mark	Page	Time of revision
	63- 9-1	③		64- 4	③		74- 6			91-35	②		91-36-39	②
	63- 9-2	③		64- 5	③		74- 7			91-36	②		91-36-40	③
	63-10	⑦		64- 6	③					91-36-1	⑤		91-36-41	②
	63-11	③		64- 8	③					91-36-2	②		91-36-42	②
	63-12			64- 9	③		91- 1			91-36-3	②		91-36-43	⑦
	63-13			64-10	③		91- 3	⑦		91-36-4	②		91-36-44	⑦
	63-14			64-11			91- 5	②		91-36-5	②		91-36-45	⑤
	63-15			64-12	③		91- 6	②		91-36-6	②		91-36-46	⑤
	63-16			64-13			91- 6-1	⑤		91-36-7	②		91-36-47	⑦
	63-17			64-13-1	③		91- 6-2	②		91-36-8	②		91-36-48	⑤
	63-18	③		64-13-2	③		91- 6-3	⑦		91-36-9	⑤		91-36-49	⑤
	63-19	③		64-15	③		91- 6-5	⑧		91-36-10	②		91-36-50	⑦
	63-20	③		64-16	③		91- 6-6	⑧		91-36-11	②		91-36-51	⑤
	63-21			64-17			91- 7			91-36-12	②		91-36-52	⑤
	63-22	③		64-18			91- 8	②		91-36-13	②		91-36-53	⑤
	63-23			64-19			91- 8-1	②		91-36-14	②		91-36-54	⑤
	63-24			64-20	③		91-10	②		91-36-15	②		91-36-55	⑦
	63-25	③					91-11			91-36-16	②		91-36-56	⑦
	63-25-1	③					91-12			91-36-17	②		91-36-57	⑦
	63-25-2	③		71- 1			91-13			91-36-18	②		91-36-58	⑦
	63-26	③		71- 3			91-14	②		91-36-19	②		91-36-60	⑦
	63-27			71- 4	②		91-15			91-36-20	②		91-36-61	⑦
	63-28						91-17	②		91-36-21	⑤		91-36-62	⑦
	63-29						91-18			91-36-22	②		91-36-63	⑦
	63-30	①		72- 1			91-19			91-36-23	②		91-36-64	⑦
	63-31			72- 3			91-20			91-36-24	②		91-36-65	⑦
	63-32			72- 4	④		91-21			91-36-25	②		91-36-66	⑦
	63-33			72- 5	④		91-22			91-36-26	②		91-36-67	⑦
	63-34			72- 6	④		91-23	②		91-36-27	②		91-36-68	⑦
	63-35						91-24	②		91-36-28	②		91-36-69	⑦
	63-36						91-25			91-36-29	②		91-36-70	⑦
	63-37			73- 1			91-26			91-36-30	②		91-36-71	⑦
	63-38			73- 3			91-27	①		91-36-31	②		91-36-72	⑦
	63-39			73- 4	③		91-28			91-36-32	②		91-36-73	⑦
	63-40			73- 5	③		91-29	①		91-36-33	②		91-36-74	⑦
	63-41	③					91-30			91-36-34	②		91-36-75	⑦
				74- 1			91-31			91-36-35	②		91-36-76	⑦
				74- 3			91-32			91-36-36	②		91-36-77	⑦
	64- 1			74- 4			91-33			91-36-37	②		91-36-78	⑦
	64- 3	③		74- 5			91-34	②		91-36-38	②		91-36-79	⑦

LIST OF REVISED PAGES

LIST OF REVISED PAGES

Mark	Page	Time of revision	Mark	Page	Time of revision	Mark	Page	Time of revision	Mark	Page	Time of revision	Mark	Page	Time of revision
	91-36-80	⑦		91-36-123	⑦		91-48	②		95-37	⑦			
	91-36-81	⑦		91-36-124	⑦		91-49	②		95-38	⑦			
	91-36-82	⑦		91-36-125	⑦		91-50	②		95-39	⑦			
	91-36-83	⑦		91-36-126	⑦					• 95-40	⑨			
	91-36-84	⑦		91-36-128	⑦					95-41	⑦			
	91-36-85	⑦		91-36-129	⑦		95- 1	⑦		95-42	⑦			
	91-36-86	⑦		91-36-130	⑦		95- 3	⑦		95-43	⑦			
	91-36-88	⑦		91-36-131	⑦		95- 4	⑦		• 95-44	⑨			
	91-36-89	⑦		91-36-132	⑦		95- 5	⑦		95-45	⑦			
	91-36-90	⑦		91-36-133	⑦		95- 6	⑦		95-46	⑦			
	91-36-91	⑦		91-36-134	⑦		95- 7	⑦		95-47	⑦			
	91-36-92	⑦		91-36-135	⑦		95- 8	⑦		• 95-48	⑨			
	91-36-93	⑦		91-36-136	⑦		95- 9	⑦		95-49	⑦			
	91-36-94	⑦		91-36-137	⑦		95-10	⑦		95-50	⑦			
	91-36-95	⑦		91-36-138	⑦		95-11	⑦		95-51	⑦			
	91-36-96	⑦		91-36-139	⑦		95-12	⑦		95-52	⑦			
	91-36-98	⑦		91-36-140	⑦		95-13	⑦		95-53	⑦			
	91-36-99	⑦		91-36-141	⑦		95-14	⑦		95-54	⑦			
	91-36-100	⑦		91-36-142	⑦		95-15	⑦						
	91-36-101	⑦		91-36-143	⑦		95-16	⑦						
	91-36-102	⑦		91-36-144	⑦		95-17	⑦						
	91-36-103	⑦		91-36-145	⑦		95-18	⑦						
	91-36-104	⑦		91-36-146	⑦		95-19	⑦						
	91-36-106	⑦		91-36-147	⑦		95-20	⑦						
	91-36-107	⑦		91-36-148	⑦		95-21	⑦						
	91-36-108	⑦		91-36-149	⑦		95-22	⑦						
	91-36-109	⑦		91-36-150	⑦		95-23	⑦						
	91-36-110	⑦		91-36-151	⑦		95-24	⑦						
	91-36-111	⑦		91-36-152	⑦		95-25	⑦						
	91-36-112	⑦		91-37	②		95-26	⑦						
	91-36-113	⑦		91-37-1	②		95-27	⑦						
	91-36-114	⑦		91-40	②		95-28	⑦						
	91-36-115	⑦		91-40-1	②		95-29	⑦						
	91-36-116	⑦		91-41	②		95-30	⑦						
	91-36-117	⑦		91-42	②		95-31	⑦						
	91-36-118	⑦		91-43	②		95-32	⑦						
	91-36-119	⑦		91-44	②		95-33	⑦						
	91-36-120	⑦		91-45	②		• 95-34	⑨						
	91-36-121	⑦		91-46	②		95-35	⑦						
	91-36-122	⑦		91-47	②		95-36	⑦						

CONTENTS

GENERAL

01	GENERAL INSTRUCTION	01-1
02	TESTING AND ADJUSTING	02-1
03	GENERAL DISASSEMBLY AND ASSEMBLY	03-1

ENGINE RELATED COMPONENT

12	TESTING AND ADJUSTING	12-1
13	DISASSEMBLY AND ASSEMBLY	13-1
16	AIR STARTER	16-1

POWER TRAIN

21	STRUCTURE AND FUNCTION	21-1
22	TESTING AND ADJUSTING	22-1
23	DISASSEMBLY AND ASSEMBLY	23-1
24	MAINTENANCE STANDARD	24-1

STEERING SYSTEM

41	STRUCTURE AND FUNCTION	41-1
42	TESTING AND ADJUSTING	42-1
43	DISASSEMBLY AND ASSEMBLY	43-1
44	MAINTENANCE STANDARD	44-1

AIR SYSTEM

51	STRUCTURE AND FUNCTION	51-1
53	DISASSEMBLY AND ASSEMBLY	53-1
54	MAINTENANCE STANDARD	54-1

HYDRAULIC CONTROL

61	STRUCTURE AND FUNCTION	61-1
62	TESTING AND ADJUSTING	62-1
63	DISASSEMBLY AND ASSEMBLY	63-1
64	MAINTENANCE STANDARD	64-1

WORK EQUIPMENT

71	STRUCTURE AND FUNCTION	71-1
72	TESTING AND ADJUSTING	72-2
73	DISASSEMBLY AND ASSEMBLY	73-1
74	MAINTENANCE STANDARD	74-1



OTHERS

91	ELECTRICAL SYSTEM	91-1
----	-------------------------	------

IMPORTANT SAFETY NOTICE

IMPORTANT SAFETY NOTICE

Proper service and repair is extremely important for the safe operation of machine. The service and repair techniques recommended by Komatsu and described in this manual are both effective and safe methods of operation. Some of these operations require the use of tools specially designed by Komatsu for the purpose.

To prevent injury to workers, the symbols  and  are used to mark safety precautions in this manual. The cautions accompanying these symbols should always be followed carefully. If any dangerous situation arises or may possibly arise, first consider safety, and take the necessary actions to deal with the situation.

FOREWORD

This shop manual has been prepared as an aid in improving the quality of repairs by giving the serviceman an accurate understanding of the product and by showing him the correct way to perform repairs and make judgements. Make sure you understand the contents of this manual and use it to full effect at every available opportunity.

Organization

This shop manual mainly contains the necessary technical information for operations performed in a service workshop.

For ease of understanding, the manual is divided into chapters for each main group of components; these chapters are further divided into the following sections.

Structure and function

This section explains the structure and function of each component. It serves not only to give an understanding of the structure, but also serves as reference material for troubleshooting.

Testing and adjusting

This section explains checks to be made before and after performing repairs, as well as adjustments to be made at completion of the checks and repairs. Troubleshooting charts correlating "Diagnoses" to "Causes" are also included in this section.

Disassembly and assembly

This section explains the order to be followed when removing, installing, disassembling or assembling each component, as well as precautions to be taken for these operations.

Maintenance standards

This section gives the judgement standards when inspecting disassembled parts.

USING THE SHOP MANUAL

Volumes

Shop manuals are issued for carrying out repairs.

They are divided as follows:

Chassis volume: issued for every machine model

Engine volume: issued for each engine series

Electrical volume :
Fuel system volume : } each issued as one volume to cover all models
Attachments volume: }

In addition, the following volumes are issued for high level rebuilding techniques to cover all models.

Engine volume

Undercarriage volume

The following volumes are issued for inspection and tests after repairs:

Guidance for reusable parts volume

Bench test methods volume

These various volumes are designed to avoid duplicating the same information. Therefore to deal with all repairs for any model, it is necessary to have the shop manual for that model as well as the relevant engine volume, the fuel system volume and the electrical volume.

This shop manual is **chassis volume**.







Distribution and Updating

Recipients of shop manuals are recorded at the Komatsu Head Office. Any additions, amendments or other changes will be sent to all recipients without fail, so someone should be appointed to be in charge of manuals. In this way, pages can be added or removed immediately and the manuals kept up to date and easy to use.

FOREWORD

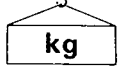
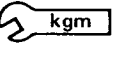
Symbols

So that the shop manual can be of sufficient practical use, we have marked important places for safety and quality with the following symbols.

SYMBOL	ITEM	REMARKS
	Safety	Special safety precautions are necessary when performing the work.
		Extra special safety precautions are necessary when performing the work because it is under internal pressure.
	Caution	Special technical precautions or other precautions for preserving standards are necessary when performing the work.
	Weight	Weight of parts or systems. Caution necessary when selecting hoisting wire, or when working posture is important, etc.
	Tightening torque	Places that require special care with the tightening torque when assembling.
	Coat	Places to be coated with adhesives, etc. when assembling.
	Oil, water	Places for filling with oil, etc. Oil capacity.
	Drain	Places for draining oil, etc. Quantity to be drained.

Network Diagrams

The standard procedures for disassembly and assembly are described and shown in photographs for each part of the machine. The sequence or steps employed in disassembly and assembly are shown in network diagrams as depicted below.

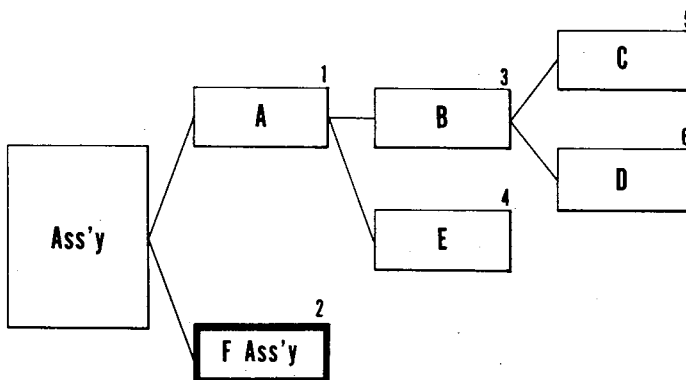

The sequence of the procedural steps is given in arabic numbers on the top right of each block. For example, when it is necessary to remove part D from the assembly, the steps for removal should be A → B → D. Or, to remove part E the step is A → E. **F Ass'y** is an assembly for which the disassembling procedure is described separately. For assembly, the sequence is presented under each section, in the same manner as for disassembly.

Troubleshooting Chart

As shown below, the symptoms relating to a particular trouble are described in the line designated "Diagnoses". The cause of the trouble is then correlated under the "Causes" column and is shown marked.

Problem No. 1 Reduced tractive power or slow travel speed.

Diagnoses	Causes		
	Oil leaks in torque converter	Air suction in the hydraulic pump	
Torque converter oil pressure gauge shows lower than normal pressure. (normal 3 ~ 4.8 kg/cm ²)	<input type="radio"/>	<input type="radio"/>	<input type="radio"/>
Transmission oil pressure gauge shows lower than normal pressure. (normal 20 ~ 23 kg/cm ²)		<input type="radio"/>	
	<input type="radio"/>		

DEFINITION

Standard Size, Tolerance

The dimensions of finished parts each differ a little. Therefore, when determining the finished dimensions of parts, a dimension that will be standard is determined provisionally, and then the difference allowed from it is indicated. The former is called the **standard size**, and the latter the **tolerance**.

The way to show this is by a plus or a minus sign with the tolerance in smaller numerals to the right the standard size.

Example: $120 \begin{smallmatrix} -0.022 \\ -0.126 \end{smallmatrix}$ (The same meaning as 119.874 – 119.978)

Moreover, when expressing the dimensions of a hole and the shaft that goes inside it, for the sake of convenience, the standard size for the hole and the shaft usually taken as the same, and the tolerances changed to indicate the tightness of the fit. For example, the fit of revolving shaft is indicated as follows, and is shown in the drawing.

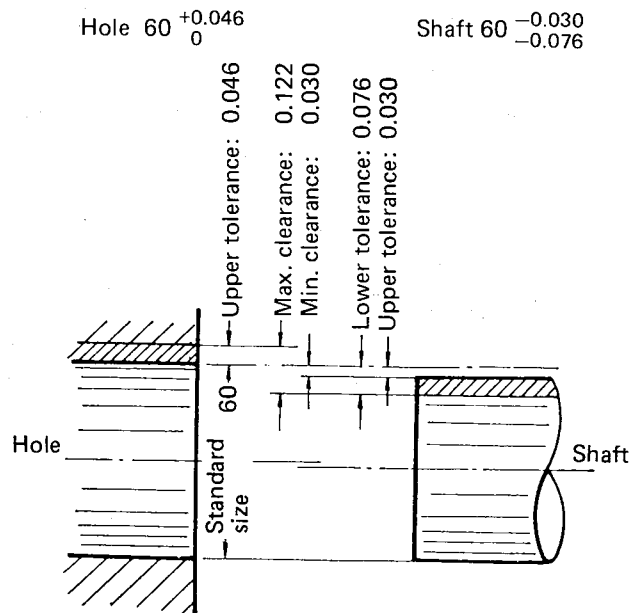

Standard Size

This is the standard value at the time of design, the finished dimension of new parts.

Repair Limit

This is the limit in dimension up to which the part can be used. (The size of parts changes due to wear or distortion during use). When parts exceed the repair limit, they must be repaired or replaced as specified.

Standard Clearance

This is the clearance between two new parts after assembly, shown as a range between minimum clearance and maximum clearance. In general, parts are adjusted to this clearance after repair.

Clearance Limit

This is the maximum clearance allowed between parts. (The clearance increases due to wear, etc. during use.)
When the clearance exceeds the clearance limit, the parts must be repaired or replaced as specified.

Maintenance Standard

This is the number given to items in diagrams of individual components. The same number is given in the left-hand column for ease of identification.

Unit: mm

No.	Check item	Criteria			Remedy
		Serial No.	Standard size	Repair limit	
1					

Unit: mm

No.	Check item	Serial No.	Standard size	Tolerance		Standard clearance	Clearance limit	Remedy
				Shaft	Hole			
				10				

PRECAUTION FOR DISASSEMBLY AND ASSEMBLY

(1) Precautions for disassembly

- Before attempting to disassemble, determine the cause of the trouble by systematically checking and analyzing the symptoms. Needless disassembly will not only hinder trouble shooting, but will also result in losses of unnecessary replacement parts and man-hour costs.
- During disassembly, carefully check every sliding part for any signs of seizing, interference or contact, since these may reveal hidden faults which could be the cause of the actual trouble.
- Unless major disassembly, based on definite reasons is to be made, the related parts should be first briefly inspected, and disassembly started after confidence in the operation is established.
- Thoroughly clean the part of the machine to be disassembled, before attempting to disassemble.
- Proceed with the disassembly by confirming the fitting conditions of the relative parts; their positions fore-and-aft, left-and-right and upper-and-lower, and the proper sequence of their removal.
- When draining lubricating oils, take note of their viscosity, color and state of contamination. Observation of used oils often provides clues to the wear condition of the lubricated parts (specially in regards to gears and bearings.)
- Put match marks across mating joints where required before separating parts. The parts should be clearly marked to prevent confusion at the time of assembly.
- For disassembly of certain designated parts, only use the special tools prescribed for this purpose.
- When a part, after removal of fastening nuts and bolts, is still found to be unremovable, never force the parts; but carefully check for the cause of the tightness.
- When looseness exists between force-fitted or taper-fitted, parts, check both of the mating surfaces for damage or wear. Repair or replace the part(s) if necessary.
- When removing a control-link assembly, be careful to maintain the original adjustment of the length of the rods unless any re-adjustment is necessary. Check the original length of each rod and record it before removal of the link assembly if it is necessary to remove the rod-end for disassembly.
- Wash disassembled parts clean, neatly arrange the parts for each assembly, and keep in storage, free from dust and dirt.
Use of two vessels filled with detergent oil, one for washing dirty parts and the other for rinsing them, is recommended for cleaning more effectively. Keep each set of shims stacked in its original arrangement so that the same clearances as before disassembly can be obtained when the machine is re-assembled.

(2) General precautions in assembly operations

- Thoroughly clean all parts before assembly. Wash clean those parts relating to the power train (main clutch, transmission, etc.). Also, check for scratches and nicks on the surfaces of the parts and repair, if any.

Wash new parts to remove rust preventives, if coated, before assembly. Use trichloroethylene or diesel fuel.

- Employ a press or a driving tool when assembling bearings, bushings and oil seals.

When installing a bearing, pay attention to keep the marking on the bearing facing outward, unless it is necessary to install otherwise because of the construction. (This permits easy indentifying of the bearing being installed.)

- Be sure to positively lock bolts and nuts which are usually invisible from the outside or used for some important parts that require locking, by the use of wires, cotter pins or lockwashers.

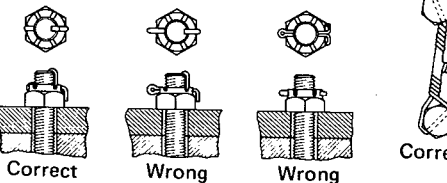
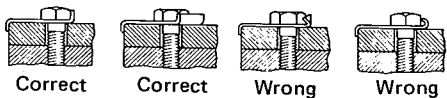
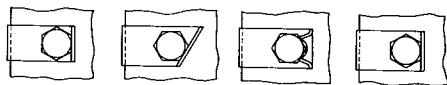

- Be sure to tighten each bolt to the specified torque with a suitable torque wrench. Apply an even tightening force to the bolts by screwing them alternately or in a criss-cross fashion.
- Apply two or three drop of LT-2 (a liquid lacker for threaded fasteners) to important bolts. While powder of LT-2 adhered to the threads of a bolt removed from a part when disassembling the party may be used as a mark indicating the depth to which the bolt is to be screwed in when reassembling the part.) Prior to coating with LT-2, wash the bolt with light oil or trichloroethylene and dary.
- Tighten bolts in the prescribed sequence as shown below by figures so that they can be tightened evenly to the specified torque.

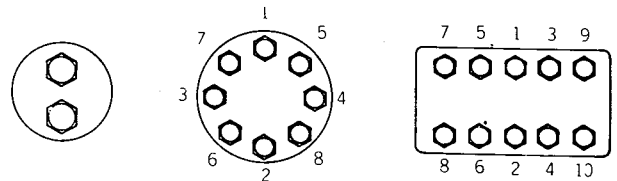

Be careful not to tighten bolts excessively.

- Be sure to align match marks if provided.
- Keep the working area, tools, worker's hands, etc. clean during assembly operation.
- Coat the surfaces of parts to be press-fitted with molybdenum disulfide grease.

FOREWORD

(3) Handling of oil seals

- Be careful to install an oil seal with its lips in a proper direction as shown below.

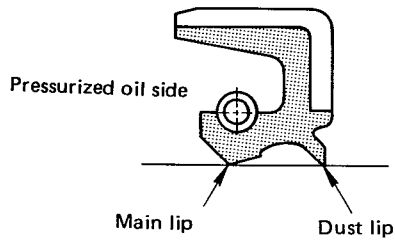

- Before installing an oil seal, coat it with grease to prevent dry-friction which may occur during the brake-in operation of the machine, according to the following procedure.
 - In case of a double-lip type, uniformly coat the surface of the groove around the lips with grease.
 - In case of a single-lip type, uniformly and evenly coat the surface surrounding the lip on the opposite side of the sealing surface of lip.

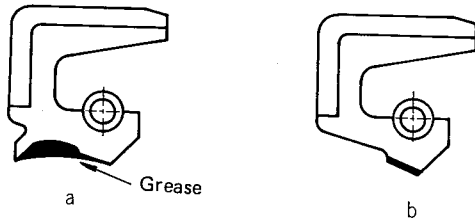

- Apply the lube oil or grease to the surface and chamfered edge of the shaft on which the oil seal is to be installed, so that the shaft may be smoothly inserted into the oil seal without pinching the lip and that a proper lubrication of the shaft during the brake-in period of the machine is accomplished.
- Be sure to apply grease only by the fingers. Restrict the amount of grease to be applied in the range of 40 to 60 percent of the vacancy formed between the lips.

- When fitting an oil seal, use of a guide shown below is recommended to prevent the lips of the oil seal from being scratched or soiled with dust.

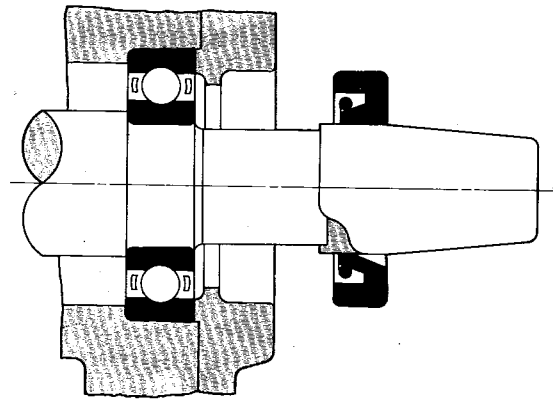

- Make sure that there is no scratch and dust on the contact surface (with the shaft) of an oil seal.
- Do not use any hydraulic press to press-fit an oil seal. Use only a hand press and a jig. The jig should be a snap cylinder of 1 to 3 mm smaller in the outside diameter than the oil seal, and the press-fit surface of the oil seal should be free from scratch and deformation.

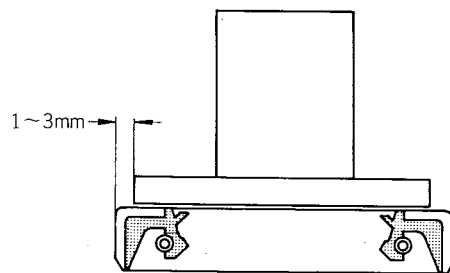

- When installed, the oil seal should not be inclined at an angle. Press-fitted angle of an oil seal should not exceed the permissible limit of 0.2 mm/100 mm dia.

(4) Handling of gaskets

- Discard copper gaskets whenever they are disassembled.
- Immerse leather gaskets in oil before assembly.
- Coat liquid gasket compound to the specially designated gaskets and O-rings.

The brand name of a liquid gasket compound available on the market is THREE-BOND HP-102 No.4. (Gaskets and O-rings to be applied with liquid gasket will be specified in each step to be after-mentioned.)

★ Precautions for coating with the liquid gasket:

- Make sure that the surface to be coated with liquid gasket is free from large scratches or any other damages.

Wipe off dust, paint or oil, if any, from the surfaces to be coated with liquid gasket.

Uniformly apply liquid gasket to the contact surface, and wait for a few minutes to allow drying of the gasket. When the liquid gasket becomes dry enough for the finger touch, put the gasket or O-ring in place.

(5) Handling of O-rings

- O-rings are provided on their circumferences with blue or green dots.
Be careful to select the most proper one for each application.

Class	Part number	Material	Application
one blue-dot	07000-0	Nitrile-rubber	Flanges and cover for low-pressure oil piping.
two blue-dots	07000-1	Nitrile-rubber	Pump body connection, cylinders and pistons for high pressure piping
one green-dot	07000-3	Fluorine-rubber	Flanges for low pressure piping
two green-dots	07000-2	Fluorine-rubber	Flanges for high-pressure piping
one red-dot	07000-4	Nitrile-rubber	Flanges for low-pressure piping
two red-dots	07000-5	Nitrile-rubber	Flanges for high-pressure piping
orange	07000-6	Silicone-rubber	Flanges for low-pressure piping

(6) Handling of floating seals

- Replace a seal, if rust exists on the circumference of its contact surface. Check a new seal to see if its contact surface is free from scratch and dust. Smooth the contact surfaces by lightly rubbing each other before fitting a seal in place.
- Apply a thin coat of oil to the contact surfaces when installing a seal.
- Insert the O-ring in the housing groove taking care not to twist the O-ring. An O-ring installed with a twisting condition will jump up out of the groove when a seal ring is turned round under pressure.
- If some difficulty exists when installing a seal ring in the housing groove, use of a bamboo spatula is recommended to help the installation. Any screwdrivers should not be used for this purpose.

(7) Handling of seal rings

- Check seal rings for any sign of scratch, nick or burr in their grooves.
- Take special care in the handling of a Teflon seal ring, since it is easily damaged and is liable to deform under excessive tension. (To remove the deformation of a Teflon seal ring, immerse it in oil at 100 to 120°C and then allow it to cool slowly.)
- Check for twisting of a Teflon seal ring which may easily arise because of its endless construction when the Teflon seal ring is fitted into a groove.
- After installation of a seal ring, coat it uniformly with grease or oil.