

# Operation & Maintenance Manual

YEAM200300

# PC60-7

## HYDRAULIC EXCAVATOR

PC60-7: SERIAL NUMBERS DBK0001 and up

PC60-7B: SERIAL DBKB001 and up



### WARNING

Unsafe use of this machine may cause serious injury or death. Operators and maintenance personnel must read this manual before operating or maintaining this machine. This manual should be kept near the machine for reference and periodically reviewed by all personnel who will come into contact with it.

### NOTICE

Komatsu has Operation & Maintenance Manuals written in some other languages. If a foreign language manual is necessary, contact your local distributor for availability.

# KOMATSU

# FOREWORD

## **CALIFORNIA**

### **Proposition 65 Warning**

Diesel engine exhaust and some of its constituents are known to the State of California to cause cancer, birth defects, and other reproductive harm.

## **CALIFORNIA**

### **Proposition 65 Warning**

Battery posts, terminals and related accessories contain lead and lead compounds, chemicals known to the State of California to cause cancer and birth defects or other reproductive harm.

**Wash hands after handling.**

# FOREWORD

This manual provides rules and guidelines which will help you use this machine safely and effectively. The precautions in this manual must be followed at all times when performing operation and maintenance. Most accidents are caused by the failure to follow fundamental safety rules for the operation and maintenance of machines. Accidents can be prevented by knowing beforehand conditions that may cause hazard when performing operation and maintenance.

## WARNING

Operators and maintenance personnel must always do as follows before beginning operation or maintenance.

- Always be sure to read and understand this manual thoroughly before performing operation and.
- Read the safety messages given in this manual and the safety labels affixed to the machine thoroughly and be sure that you understand them fully.

Keep this manual at the storage location for the Operation and Maintenance Manual given below, and have all personnel read it periodically.

If this manual has been lost or has become dirty and cannot be read, request a replacement manual immediately from Komatsu or your Komatsu distributor.

If you sell the machine, be sure to give this manual to the new owners together with the machine.

Komatsu delivers machines that comply with all applicable regulations and standards of the country to which it has been shipped. If this machine has been purchased in another country or purchased from someone in another country, it may lack certain safety devices and specifications that are necessary for use in your country. If there is any question about whether your product complies with the applicable standards and regulations of your country, consult Komatsu or your Komatsu distributor before operating the machine.

Storage location for the Operation and Maintenance Manual:

Manual luggage box behind operator's seat

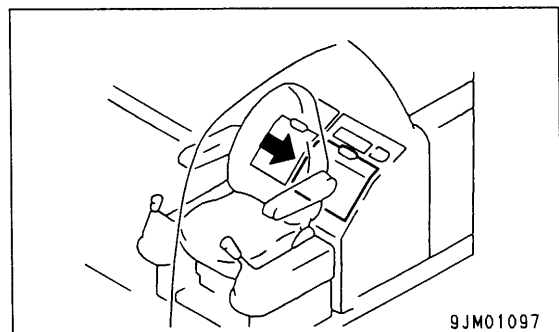

9JM01097

## EMISSION CONTROL WARRANTY

## EMISSION CONTROL WARRANTY STATEMENT (APPLIES TO CANADA ONLY)

**1. Products Warranted**

Komatsu America International Company, Komatsu Mining Systems Inc. and Komatsu Utility Corporation (collectively "Komatsu") produce and/or market products under brand names of Komatsu, Dresser, Dressta, Haulpak and Galion. This emissions warranty applies to new engines bearing the Komatsu name installed in these products and used in Canada in machines designed for industrial off-highway use. This warranty applies only to these engines produced on or after January 1, 2000. This warranty will be administered by Komatsu distribution in Canada.

**2. Coverage**

Komatsu warrants to the ultimate purchaser and each subsequent purchaser that the engine is designed, built and equipped so as to conform, at the time of sale by Komatsu, with all U.S. Federal emission regulations applicable at the time of manufacture and that it is free from defects in workmanship or material which would cause it not to meet these regulations within five years or 3,000 hours of operation, whichever occurs first, as measured from the date of delivery of the engine to the ultimate purchaser.

**3. Limitations**

Failures, other than those resulting from defects in materials or workmanship, are not covered by this warranty. Komatsu is not responsible for failures or damage resulting from what Komatsu determines to be abuse or neglect, including, but not limited to: operation without adequate coolant or lubricants; over fueling; over speeding; lack of maintenance of lubricating, cooling or intake systems; improper storage, starting, warm-up, run-in or shutdown practices; unauthorized modifications of the engine. Komatsu is also not responsible for failures caused by incorrect fuel or by water, dirt or other contaminants in the fuel. Komatsu is not responsible for non-engine repairs, "downtime" expense, related damage, fines, all business costs or other losses resulting from a warrantable failure.

**KOMATSU IS NOT RESPONSIBLE FOR INCIDENTAL OR CONSEQUENTIAL DAMAGES.**

This warranty, together with the express commercial warranties, are the sole warranties of Komatsu. **THERE ARE NO OTHER WARRANTIES, EXPRESS OR IMPLIED, OR OF MERCHANTABILITY OR FITNESS FOR A PARTICULAR PURPOSE.**

## GARANTIE SUR LE CONTRÔLE DES ÉMISSIONS

## ÉNONCÉ DE GARANTIE SUR LE CONTRÔLE DES ÉMISSIONS (APPLICABLE AU CANADA SEULEMENT):

**1. Produits garantis:**

Komatsu America International Company, Komatsu Mining Systems Inc. et Komatsu Utility Corporation (collectivement Komatsu) produisent et/ou font la mise en marché de produits portant les noms de marque Komatsu, Dresser, Dressta, Haulpak et Galion. Cette garantie sur les émissions s'applique à tous les nouveaux moteurs portant le nom Komatsu, installés dans ces produits et utilisés au Canada dans des machines conçues pour utilisation industrielle non-routière. Cette garantie s'applique seulement sur les moteurs produits à partir du 1er Janvier 2000. Cette garantie sera administrée par la distribution de Komatsu au Canada.

**2. Couverture:**

Komatsu garantit à l'acheteur ultime et chaque acheteur subséquent que le moteur est conçu, construit et équipé en toute conformité, au moment de la vente par Komatsu, avec toutes les Réglementations fédérales américaines sur les émissions applicables au moment de la fabrication et qu'il est exempt de défauts de construction ou de matériaux qui auraient pour effet de contrevenir à ces réglementations en dedans de 5 ans ou 3000 heures d'opération, mesuré à partir de la date de livraison du moteur au client ultime.

**3. Limitations:**

Les bris, autres que ceux résultant de défauts de matériaux ou de construction, ne sont pas couverts par cette Garantie. Komatsu n'est pas responsable pour bris ou dommages résultant de ce que Komatsu détermine comme étant de l'abus ou négligence, incluant mais ne se limitant pas à: l'opération sans lubrifiants ou agent refroidissants adéquats; la suralimentation d'essence; la survitesse; le manque d'entretien des systèmes de lubrification, de refroidissement ou d'entrée; de pratiques non-propices d'entreposage, de mise en marche, de réchauffement, de conditionnement ou d'arrêt; les modifications non-autorisées du moteur. De plus, Komatsu n'est pas responsable de bris causés par de l'essence inadéquate ou de l'eau, des saletés ou autres contaminants dans l'essence. Komatsu n'est pas responsable des réparations non-relies au moteur, des dépenses encourues suite aux temps d'arrêts, des dommages relatifs, amendes, et de tout autre coût d'affaires ou autres pertes résultant d'un bris couvert par la garantie.

**KOMATSU N'EST PAS RESPONSABLE DES INCIDENTS OU DOMMAGES CONSÉQUENTS.**

Cette garantie, ainsi que les garanties expresses commerciales, sont les seules garanties de Komatsu. **IL N'Y A AUCUNE AUTRE GARANTIE, EXPRESSE OU SOUS-ENTENDUE, MARCHANDABLE OU PROPICE A UNE UTILISATION PARTICULIÈRE.**

**INFORMATION IMPORTANTE SUR LE MOTEUR**  
 CE MOTEUR EST CONFORME AUX NORMES AMÉRICAINES DE L'EPA (ANNÉE DU MODÈLE) ET DE LA CALIFORNIE POUR LES MOTEURS LARGES NON-ROUTIERS À IGNITION PAR COMPRESSION. CE MOTEUR EST CERTIFIÉ POUR OPERATION À ESSENCE DIESEL.

**AVERTISSEMENT**  
 DES BLESSURES PEUVENT RESULTER ET LA GARANTIE S'ANNULER SI LES RPM DU TAUX D'ESSENCE OU L'ALTITUDE EXCÈDENT LES VALEURS MAXIMALES PUBLIÉES POUR CE MODÈLE ET SON APPLICATION.

**IMPORTANT ENGINE INFORMATION**

THIS ENGINE CONFORMS TO YYYY MODEL YEAR U.S. EPA REGULATION AND THE CALIFORNIA REGULATIONS LARGE NON ROAD COMPRESSION IGNITION ENGINES. THIS ENGINE IS CERTIFIED TO OPERATE ON DIESEL FUEL.

**WARNING**  
 INJURY MAY RESULT AND WARRANTY IS VOIDED IF FUEL RATE RPM OR ALTITUDES EXCEED PUBLISHED MAXIMUM VALUES FOR THIS MODEL AND APPLICATION.

ENGINE MODEL	SERIAL NO.	DISPLACEMENT	LITERS
ENGINE FAMILY	PIRING ORDER		LITERS
EXHAUST EMISSION CONTROL SYSTEM		1 - 5 - 3 - 6 - 2 - 4	
ADV. LOAD OUTPUT	Kw ( HP)	RPM	
VALVE LASH COLD (mm)	IN.	EX. FUEL RATE AT ADV.	mm <sup>3</sup> /STROKE
IDLE SPEED	RPM	FAMILY EMISSION LIMIT	
INITIAL INJECTION TIMING	DEG. BTDC	DATE OF MANUFACTURE	
		KOMATSU LTD. MADE IN JAPAN	

MODÈLE DU MOTEUR

FAMILLE DU MOTEUR

SYSTÈME DE CONTRÔLE DES ÉMISSIONS D'ÉCHAPPEMENT

CHARGE DE SORTIE ADV.

PORTÉE DE VALVE À FROID (mm)

VITESSE STATIQUE

RÉGLAGE DE L'ALLUMAGE - INJECTION INITIALE

DBG. BTDC

NO. SÉRIE

DÉPLACEMENT

LITRES

SÉQUENCE DE MISE À FEU

mm<sup>3</sup>/BATTEMENT

TAUX D'ESSENCE À ADV.

LIMITÉ D'ÉMISSION DE LA FAMILLE

DATE DE FABRICATION

KOMATSU LTDÉE  
 FABRIQUÉ AU JAPON

ENGINE DATAPLATE - ENGLISH / FRENCH

# SAFETY INFORMATION

To enable you to use this machine safely, safety precautions and labels are given in this manual and affixed to the machine to give explanations of situations involving potential hazards and of the methods of avoiding such situations.

## Signal words

The following signal words are used to inform you that there is a potential hazardous situation that may lead to personal injury or damage.

In this manual and on machine labels, the following signal words are used to express the potential level of hazard.

**⚠ DANGER** Indicates an imminently hazardous situation which, if not avoided, will result in death or serious injury. This signal word is to be limited to most extreme situations.

**⚠ WARNING** Indicates a potentially hazardous situation which, if not avoided, could result in death or serious injury.

**⚠ CAUTION** Indicates a potentially hazardous situation which, if not avoided, may result in minor or moderate injury. It may also be used to alert against unsafe practices.

## Example of safety message using signal word

**⚠ WARNING**  
To avoid hitting unlocked operation levers, lower equipment to ground and move SAFETY LOCK LEVEP (located near seat) to LOCK position before starting up from operator's seat. Sudden and unwanted machine movement can cause serious injury or death.

## Other signal words

In addition to the above, the following signal words are used to indicate precautions that should be followed to protect the machine or to give information that is useful to know.

**NOTICE** This word is used for precautions that must be taken to avoid actions which could shorten the life of the machine.

**REMARKS** This gives information that is useful to know.

### Safety labels

Safety labels are affixed to the machine to inform the operator or maintenance worker on the spot when carrying out operation or maintenance of the machine that may involve hazard.

This machine uses "Safety labels using words" and "Safety labels using pictograms" to indicate safety procedures.

### Example of safety label using words

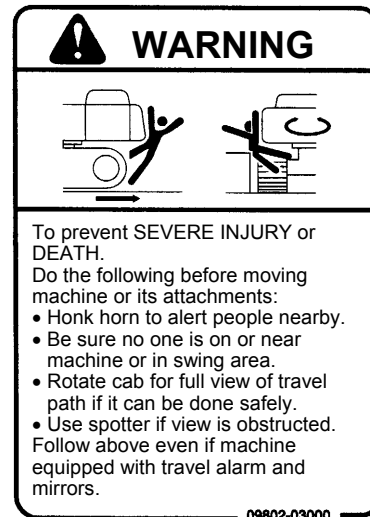

Part No.

### Safety labels using pictogram

Safety pictograms use a picture to express a level of hazardous condition equivalent to the signal word. These safety pictograms use pictures in order to let the operator or maintenance worker understand the level and type of hazardous condition at all times. Safety pictograms show the type of hazardous condition at the top or left side, and the method of avoiding the hazardous condition at the bottom or right side. In addition, the type of hazardous condition is displayed inside a triangle and the method of avoiding the hazardous condition is shown a circle.



Part No.

Komatsu cannot predict every circumstance that might involve a potential hazard in operation and maintenance. Therefore, the safety messages in this manual and on the machine may not include all possible safety precautions. If any procedures or actions not specifically recommended or allowed in this manual are used, it is your responsibility to take the necessary steps to ensure safety.

In no event should you engage in prohibited uses or actions described in this manual.

The explanations, values, and illustrations in this manual were prepared based on the latest information available at that time. Continuing improvements in the design of this machine can lead to changes in detail which may not be reflected in this manual. Consult Komatsu or your Komatsu distributor for the latest available information of your machine or for questions regarding information in this manual.

The numbers in circles in the illustrations correspond to the numbers in ( ) in the text. (For example: ① --> (1) )

# INTRODUCTION

This Komatsu HYDRAULIC EXCAVATOR is designed to be used mainly for the following works:

- Digging work
- Leveling work
- Ditching work
- Loading work
- Demolition work

See the section "RECOMMENDED APPLICATIONS (PAGE 3-70)" for further details.

## DIRECTIONS OF MACHINE

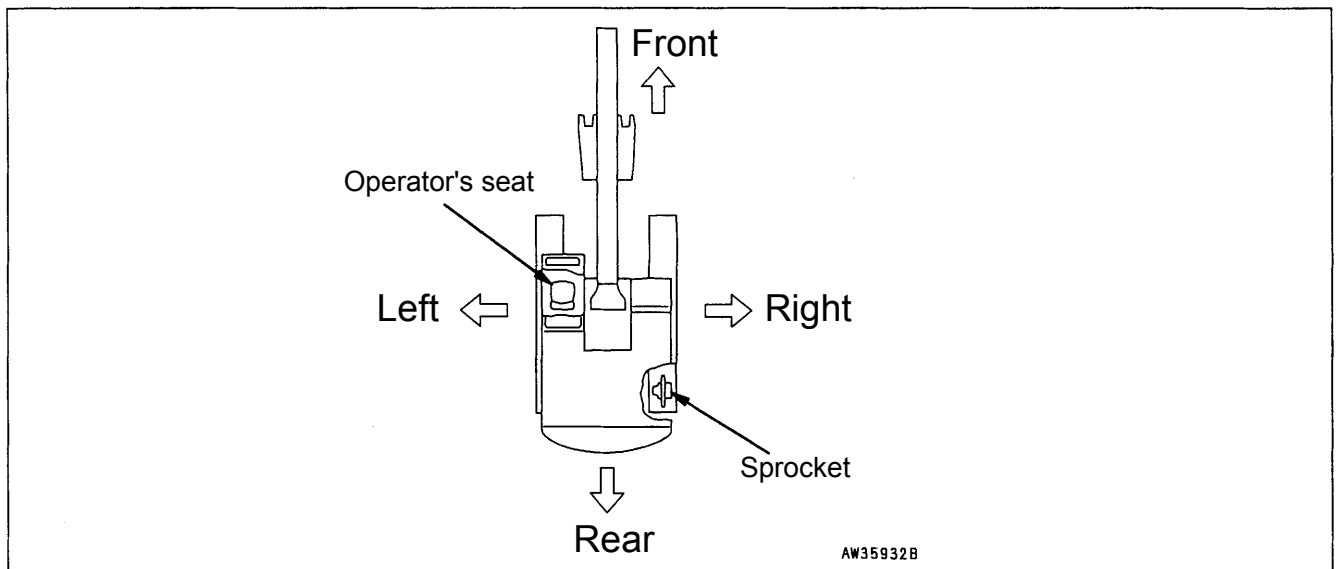

In this manual, the terms front, rear, left, and right refer to the travel direction as seen from the operator's cab when the operator's cab is facing the front and the sprocket is at the rear of the machine.



# PRODUCT INFORMATION

When requesting service or ordering replacement parts, please inform your Komatsu distributor of the following items.

## MACHINE SERIAL NUMBER PLATE AND ITS LOCATION

On the bottom right of the operator's cab

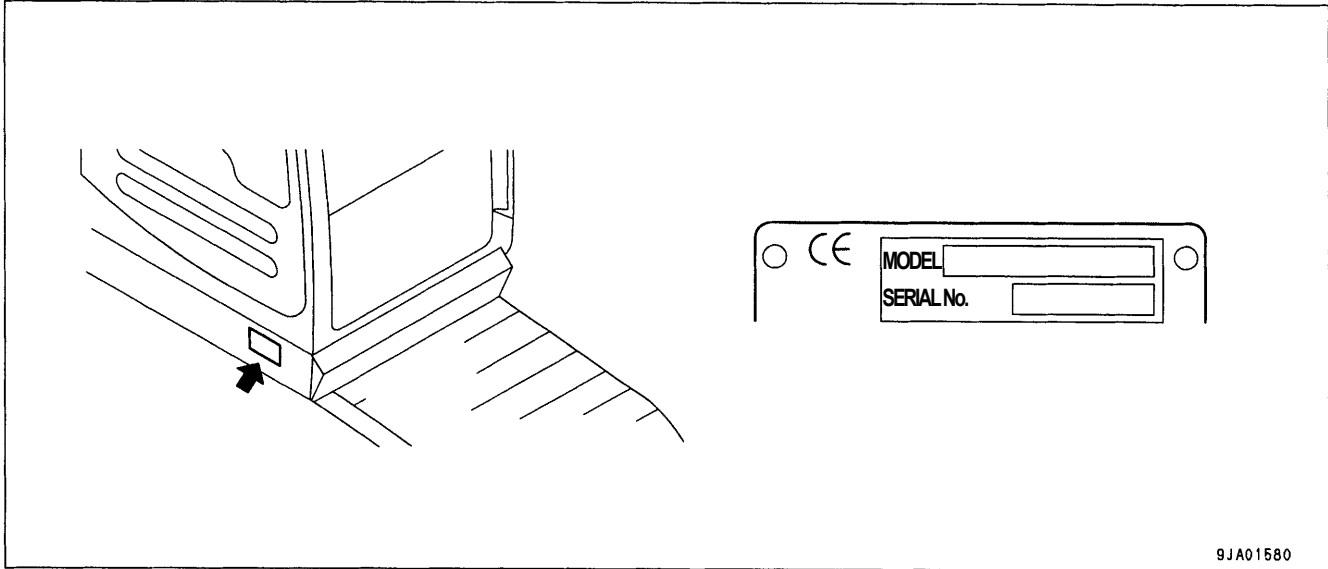

9JA01580

## ENGINE SERIAL NUMBER PLATE AND ITS LOCATION

On the upper side of the engine cylinder head cover

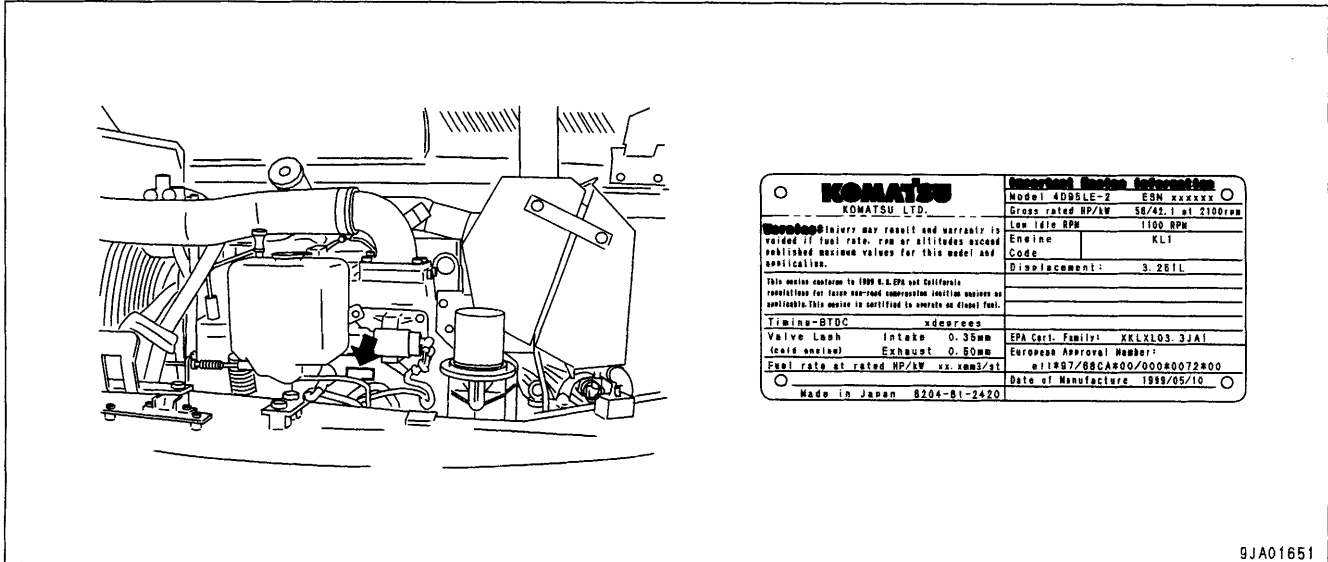

9JA01651

# SERVICE METER LOCATION

On top of the machine monitor

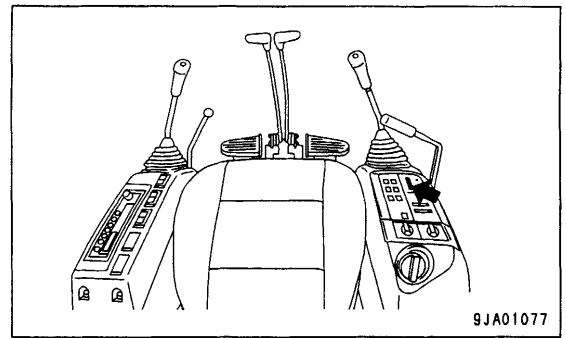

# YOUR MACHINE SERIAL NUMBERS AND DISTRIBUTOR

Machine serial No.	
Engine serial No.	
Distributor name	
Address	.....
	.....
	.....
Service Personal	.....
Phone/Fax	

# CONTENTS

## FOREWORD

<b>FOREWORD</b> .....	1-2
<b>SAFETY INFORMATION</b> .....	1-5
<b>INTRODUCTION</b> .....	1-7
DIRECTIONS OF MACHINE .....	1-7
<b>PRODUCT INFORMATION</b> .....	1-8
MACHINE SERIAL NUMBER PLATE AND ITS LOCATION.....	1-8
ENGINE SERIAL NUMBER PLATE AND ITS LOCATION .....	1-8
SERVICE METER LOCATION .....	1-9
YOUR MACHINE SERIAL NUMBERS AND DISTRIBUTOR.....	1-9

## SAFETY

<b>SAFETY INFORMATION</b> .....	2-2
<b>WARNING LABELS AND PICTOGRAMS</b> .....	2-4
WARNING LABELS AND PICTOGRAMS - LOCATION .....	2-5
WARNING LABELS AND PICTOGRAMS - ACTUAL .....	2-6
<b>SAFETY INFORMATION</b> .....	2-10
<b>SAFETY MACHINE OPERATION</b> .....	2-19
BEFORE STARTING ENGINE .....	2-19
AFTER STARTING ENGINE .....	2-21
TRANSPORTATION.....	2-27
BATTERY .....	2-29
TOWING .....	2-31
LIFTING OBJECTS WITH BUCKET .....	2-32
<b>SAFETY MAINTENANCE INFORMATION</b> .....	2-33

## OPERATION

<b>MACHINE VIEW ILLUSTRATIONS</b> .....	3-2
OVERALL MACHINE VIEW.....	3-2
CONTROLS AND GAUGES .....	3-3
<b>DETAILED CONTROLS AND GAUGES</b> .....	3-4
MONITORING SYSTEM.....	3-4
SWITCHES .....	3-10

CONTROL LEVERS AND PEDALS .....	3-15
SUN ROOF .....	3-19
ENGINE HOOD .....	3-20
WINDSHIELD .....	3-21
EMERGENCY EXIT FROM OPERATOR'S CAB .....	3-24
DOOR LOCK .....	3-24
CAP WITH LOCK .....	3-25
ASHTRAY .....	3-26
RADIO .....	3-27
FUSE .....	3-31
FUSIBLELINK .....	3-31
CONTROLLERS .....	3-32
OPERATION MANUAL STORAGE .....	3-32
TOOL BOX .....	3-32
GREASE GUN HOLDER .....	3-32
<b>MACHINE OPERATIONS AND CONTROLS .....</b>	<b>3-33</b>
BEFORE STARTING ENGINE .....	3-33
STARTING ENGINE .....	3-46
AFTER STARTING ENGINE .....	3-49
STOPPING THE ENGINE .....	3-52
CHECK AFTER SHUT OFF ENGINE .....	3-52
MACHINE OPERATION .....	3-53
STEERING THE MACHINE .....	3-57
SWINGING .....	3-59
WORK EQUIPMENT CONTROLS AND OPERATIONS .....	3-60
PROHIBITED OPERATIONS .....	3-62
GENERAL OPERATION INFORMATION .....	3-66
TRAVELING ON SLOPES .....	3-67
ESCAPE FROM MUD .....	3-69
RECOMMENDED APPLICATIONS .....	3-70
BUCKET REPLACEMENT AND INVERSION .....	3-72
PARKING MACHINE .....	3-75
MACHINE INSPECTION AFTER DAILY WORK .....	3-76
LOCKING .....	3-77
RUBBER SHOES AND ROAD LINERS .....	3-78
<b>TRANSPORTATION .....</b>	<b>3-83</b>
TRANSPORTATION PROCEDURE .....	3-83
LOADING AND UNLOADING WITH TRAILER .....	3-84
LIFTING MACHINE .....	3-90
<b>COLD WEATHER OPERATION .....</b>	<b>3-93</b>
COLD WEATHER OPERATION INFORMATION .....	3-93
AFTER DAILY WORK COMPLETION .....	3-95
AFTER COLD WEATHER SEASON .....	3-96
<b>LONG TERM STORAGE .....</b>	<b>3-97</b>
BEFORE STORAGE .....	3-97

DURING STORAGE ..... 3-97

AFTER STORAGE ..... 3-98

STARTING MACHINE AFTER LONG-TERM STORAGE ..... 3-98

**TROUBLES AND ACTIONS** ..... 3-99

    RUNNING OUT OF FUEL ..... 3-99

    PHENOMENA THAT ARE NOT FAILURES ..... 3-99

    TOWING THE MACHINE ..... 3-100

    LIGHTWEIGHT TOWING HOOK ..... 3-100

    SEVERE JOB CONDITION ..... 3-100

    DISCHARGED BATTERY ..... 3-101

    OTHER TROUBLE ..... 3-105

**MAINTENANCE**

**MAINTENANCE INFORMATION** ..... 4-2

**LUBRICANTS, COOLANT AND FILTERS** ..... 4-5

    HANDLING OIL, FUEL, COOLANT, AND PERFORMING OIL CLINIC ..... 4-5

    ELECTRIC SYSTEM MAINTENANCE ..... 4-8

**WEAR PARTS** ..... 4-9

    WEAR PARTS LIST ..... 4-9

**FUEL, COOLANT AND LUBRICANTS ACCORDING TO AMBIENT TEMPERATURE** ..... 4-10

    PROPER SELECTION ..... 4-10

**TIGHTENING TORQUE SPECIFICATIONS** ..... 4-14

    TIGHTENING TORQUE LIST ..... 4-14

**PERIODIC REPLACEMENT OF SAFETY CRITICAL PARTS** ..... 4-15

    SAFETY CRITICAL PARTS ..... 4-15

**MAINTENANCE SCHEDULE** ..... 4-16

    MAINTENANCE SCHEDULE CHART ..... 4-16

    MAINTENANCE INTERVAL FOR HYDRAULIC BREAKER ..... 4-18

**MAINTENANCE PROCEDURE** ..... 4-19

    INITIAL 250 HOURS MAINTENANCE (ONLY AFTER THE FIRST 250 HOURS) ..... 4-19

    WHEN REQUIRED ..... 4-20

    CHECK BEFORE STARTING ..... 4-51

    EVERY 50 HOURS MAINTENANCE ..... 4-52

    EVERY 100 HOURS MAINTENANCE ..... 4-53

    EVERY 250 HOURS MAINTENANCE ..... 4-56

    EVERY 500 HOURS MAINTENANCE ..... 4-61

    EVERY 1000 HOURS MAINTENANCE ..... 4-67

    EVERY 2000 HOURS MAINTENANCE ..... 4-69

    EVERY 4000 HOURS MAINTENANCE ..... 4-71

    EVERY 5000 HOURS MAINTENANCE ..... 4-72

## SPECIFICATIONS

SPECIFICATIONS .....	5-2
----------------------	-----

## ATTACHMENTS AND OPTIONS

<b>ATTACHMENTS AND OPTIONS AND OPTIONS - GENERAL INFORMATION</b> .....	6-2
SAFETY FIRST .....	6-2
ATTACHMENT INSTALLATION .....	6-4
<b>BUCKET WITH HOOK</b> .....	6-5
HOOK CONDITION .....	6-5
PROHIBITED OPERATIONS .....	6-5
<b>AIR CONDITIONER</b> .....	6-6
CONTROL PANEL .....	6-6
AIR CONDITIONER CONTROLS .....	6-11
AIR CONDITIONER MAINTENANCE .....	6-11
<b>MACHINE READY FOR ATTACHMENT</b> .....	6-17
LOCATIONS .....	6-17
HYDRAULIC CIRCUIT .....	6-20
ATTACHMENT OPERATIONS .....	6-23
ACCUMULATOR .....	6-25
LONG TERM STORAGE .....	6-26
SPECIFICATIONS .....	6-27
<b>ATTACHMENT GUIDE</b> .....	6-28
ATTACHMENT COMBINATIONS .....	6-28
SELECTION OF TRACK SHOES .....	6-29
<b>AUTOMATIC GREASING SYSTEM</b> .....	6-30
CONTROLLER .....	6-30
<b>RECOMMENDED ATTACHMENT OPERATIONS</b> .....	6-36
HYDRAULIC BREAKER .....	6-36

**MEMO**

# SAFETY

 **WARNING**

**Please be sure that you fully understand this manual and the precautions related to safety for the machine, always follow these precautions strictly.**

---



# SAFETY INFORMATION

WARNING LABELS AND PICTOGRAMS.....	2-4
WARNING LABELS AND PICTOGRAMS - LOCATION .....	2-5
WARNING LABELS AND PICTOGRAMS - ACTUAL .....	2-6
SAFETY INFORMATION	
Safety Rules.....	2-10
If Abnormalities are Found .....	2-10
Working Wear and Personal Protective Items.....	2-10
Fire Extinguisher and First Aid Kit.....	2-10
Safety Equipment.....	2-11
Keep Machine Clean.....	2-11
Keep Operator's Compartment Clean .....	2-11
Leaving Operator's Seat with Lock.....	2-11
Handrails and Steps.....	2-12
Mounting and Dismounting .....	2-13
No Persons on Attachments .....	2-13
Burn Prevention .....	2-13
Fire Prevention and Explosion Prevention .....	2-14
Action If Fire Occurs .....	2-15
Windshield Washer Fluid .....	2-15
Falling Objects, Flying Objects and Intruding Objects Prevention.....	2-15
Attachment Installation.....	2-15
Attachment Combinations.....	2-16
Cab Window Glasses.....	2-16
Unauthorized Modifications.....	2-16
Safety at Jobsite .....	2-16
Working on Loose Ground .....	2-16
Distance to High Voltage Cables .....	2-17
Ensure Good Visibility.....	2-17
Ventilation for Enclosed Area.....	2-18
Signalman's Signal and Signs.....	2-18
Emergency Exit from Operator's Cab.....	2-18
Asbestos Dust Hazard Prevention .....	2-18

SAFETY MACHINE OPERATION ..... 2-19

- BEFORE STARTING ENGINE ..... 2-19
  - Checks Before Starting Engine ..... 2-19
  - Safety Rules for Starting Engine ..... 2-20
  - Starting Engine in Cold Weather ..... 2-20
- AFTER STARTING ENGINE ..... 2-21
  - Check After Starting Engine ..... 2-21
  - Safety Rules for Changing Machine Directions ..... 2-21
  - Safety Rules for Traveling ..... 2-22
  - Traveling on Slopes ..... 2-23
  - Operations on Slopes ..... 2-24
  - Prohibited Operations ..... 2-24
  - Operations on Snow ..... 2-25
  - Parking Machine ..... 2-26
- TRANSPORTATION ..... 2-27
  - Loading and Unloading ..... 2-27
  - Shipping the Machine ..... 2-28
- BATTERY ..... 2-29
  - Battery Hazard Prevention ..... 2-29
  - Starting Engine with Booster Cables ..... 2-30
- TOWING ..... 2-31
  - Safety Rules for Towing ..... 2-31
- LIFTING OBJECTS WITH BUCKET ..... 2-32
  - Safety Rules for Lifting Objects ..... 2-32
- SAFETY MAINTENANCE INFORMATION ..... 2-33
  - Warning Tag ..... 2-33
  - Keep Work Place Clean and Tidy ..... 2-33
  - Appoint Leader when Working with Others ..... 2-33
  - Stop Engine Before Carrying Out Maintenance ..... 2-34
  - Two Workers for Maintenance when Engine is Running ..... 2-35
  - Proper Tools ..... 2-35
  - Accumulator ..... 2-35
  - Personnel ..... 2-36
  - Attachments ..... 2-36
  - Work Under the Machine ..... 2-36
  - Noise ..... 2-36
  - When Using Hammer ..... 2-37
  - Welding Works ..... 2-37
  - Removing Battery Terminals ..... 2-37
  - Safety First when Using High-pressure Grease to Adjust Track Tension ..... 2-37
  - Do Not Disassemble Recoil Springs ..... 2-38
  - Safety Rules for High-pressure Oil ..... 2-38
  - Safety Handling High-pressure Hoses ..... 2-38
  - Waste Materials ..... 2-39
  - Air Conditioner Maintenance ..... 2-39
  - Compressed Air ..... 2-39
  - Periodic Replacement of Safety Critical Parts ..... 2-39

## WARNING LABELS AND PICTOGRAMS

The following warning signs and safety labels are used on this machine.

- Be sure that you fully understand the correct position and content of labels.
- To ensure that the content of labels can be read properly. Be sure that they are in the correct place and always keep them clean. When cleaning them, do not use organic solvents or gasoline, there may cause the labels to peel off.
- There are also other labels in addition to the warning signs and safety labels. Handle those labels in the same way.
- If the labels are damaged, lost, or cannot be read properly, replace them with new ones. For details of the part numbers for the labels, see this manual or the actual label, and place an order with Komatsu distributor.

## WARNING LABELS AND PICTOGRAMS - LOCATION

