

Shop Manual

HYDRAULIC
EXCAVATOR

PC240LC-10

SERIAL NUMBERS 90001 and up

KOMATSU

SHOP MANUAL

HYDRAULIC EXCAVATOR

PC240LC-10

Model Serial Number

PC240LC-10 90001 and up

00 Index and foreword

Index

00 Index and foreword	00-1
Index	00-2
Foreword, safety and general information	00-14
Important safety notice	00-14
How to read the shop manual	00-19
Explanation of terms for maintenance standard	00-21
Handling of hydraulic equipment	00-23
Method of disconnecting and connecting push-pull type coupler	00-25
Handling of electrical equipment	00-28
How to read electric wire code	00-36
Precautions when performing operation	00-39
Standard tightening torque table	00-42
List of abbreviation	00-46
Conversion table	00-51
01 Specification	01-1
Table of contents	01-2
Specifications	01-3
Specification drawings	01-3
Working range drawings	01-4
Specifications	01-5
Weight table	01-8
Table of fuel, coolant and lubricants	01-9
10 Structure and function	10-1
Table of contents	10-2
Engine and cooling system	10-3
Engine related parts	10-3
Cooling system	10-5
Power train	10-7
Power train	10-7
Swing circle	10-9
Swing machinery	10-10
Final drive	10-12
Undercarriage and frame	10-14
Track frame and idler cushion	10-14
Hydraulic system	10-16
Hydraulic equipment layout drawing	10-16
Valve control	10-18
Hydraulic tank	10-20
CLSS	10-22
Main pump	10-27
Control valve	10-51
Swing motor	10-105
Travel motor	10-116
PPC valve	10-129
Solenoid valve	10-150
Attachment circuit selector valve (for high pressure circuit)	10-153
Attachment circuit selector valve (for low pressure circuit)	10-155
Center swivel joint	10-158
Accumulator	10-160
Work equipment	10-161
Work equipment	10-161
Work equipment shim	10-162
Bucket play adjustment shim	10-163
Cab and its attachments	10-164
Cab mount and cab tipping stopper	10-164
ROPS cab	10-165
Electrical system	10-166

Electrical control system	10-166
Machine monitor system	10-209
KOMTRAX system	10-230
Sensors	10-232
20 Standard value table	20-1
Table of contents	20-2
Standard service value table	20-3
Standard value table for engine related parts	20-3
Standard value table for chassis related parts	20-4
Posture of machine for measuring performance and measurement procedure	20-13
30 Testing Adjusting	30-1
Table of contents	30-2
General information on testing and adjusting	30-3
Tools for testing and adjusting	30-3
Sketch of tools for testing and adjusting	30-7
Engine and cooling system	30-9
Checking engine speed	30-9
Measuring boost pressure	30-10
Measuring exhaust gas color	30-11
Measuring and adjusting valve clearance	30-13
Measuring compression pressure	30-16
Measuring blowby pressure	30-20
Measuring engine oil pressure	30-21
Measuring EGR valve and KVGT oil pressure	30-22
Measuring fuel pressure	30-23
Measuring fuel delivery, return and leakage	30-29
Bleeding air from fuel system	30-34
Checking fuel circuit for leakage	30-36
Handling cylinder cutout mode operation	30-37
Handling no injection cranking operation	30-38
Checking and adjusting air conditioner compressor belt tension	30-39
Replacing fan belt	30-40
Power train	30-41
Testing swing circle bearing clearance	30-41
Undercarriage and frame	30-42
Testing and adjusting track shoe tension	30-42
Hydraulic system	30-43
Releasing remaining pressure from hydraulic circuit	30-43
Measuring and adjusting of oil pressure in work equipment, swing, and travel circuits	30-44
Measuring oil pressure in control circuit	30-48
Measuring and adjusting oil pressure in pump PC control circuit	30-49
Measuring and adjusting oil pressure in pump LS control circuit	30-52
Measuring solenoid valve output pressure	30-57
Measuring PPC valve output pressure	30-60
Adjusting play of work equipment and swing PPC valves	30-62
Testing pump swash plate sensor	30-63
Isolating the parts causing hydraulic drift in work equipment	30-64
Measuring oil leakage	30-65
Bleeding air from hydraulic circuit	30-68
Cab and its attachments	30-70
Checking cab tipping stopper	30-70
Adjusting mirrors	30-71
Electrical system	30-73
Special functions of machine monitor	30-73
Angle adjustment of rear view camera	30-142
Handling voltage circuit of engine controller	30-144
Handling battery disconnect switch	30-145
Testing diodes	30-146
Pm clinic	30-147

Pm clinic service	30-147
40 Troubleshooting	40-1
Table of contents	40-2
General information on troubleshooting	40-9
Instruction on troubleshooting	40-9
How to proceed troubleshooting	40-11
Testing before troubleshooting	40-12
Testing procedure before troubleshooting	40-14
Preparation work for troubleshooting of electrical system	40-42
Classification and procedure for troubleshooting	40-46
Symptom of probable failure and troubleshooting No.	40-49
Information mentioned in troubleshooting table	40-52
Diagnostic procedure for wiring harness open circuit of pressure sensor system	40-55
Connector list and layout	40-57
Connector contact identification	40-68
T-branch box and T-branch adapter table	40-105
Fuse list and location	40-111
Precautions for cleaning and replacing KDPF (KCSF, KDOC)	40-113
Failure codes table	40-115
Troubleshooting by failure code (Display of code)	40-124
Failure code [879AKA] A/C Inner Sensor Open Circuit	40-124
Failure code [879AKB] A/C Inner Sensor Short Circuit	40-125
Failure code [879BKA] A/C Outer Sensor Open Circuit	40-126
Failure code [879BKB] A/C Outer Sensor Short Circuit	40-127
Failure code [879CKA] Ventilating Sensor Open Circuit	40-128
Failure code [879CKB] Ventilating Sensor Short Circuit	40-129
Failure code [879DKZ] Sunlight Sensor Open or Short Circuit	40-130
Failure code [879EMC] Ventilation Damper Abnormality	40-131
Failure code [879FMC] Air Mix Damper Abnormality	40-132
Failure code [879GKX] Refrigerant Abnormality	40-133
Failure code [989L00] Engine Controller Lock Caution1	40-134
Failure code [989M00] Engine Controller Lock Caution2	40-135
Failure code [989N00] Engine Controller Lock Caution3	40-136
Failure code [A1U0N3] HC desorb request1	40-137
Failure code [A1U0N4] HC desorb request2	40-139
Failure code [AA10NX] Air Cleaner Clogging	40-141
Failure code [AB00KE] Charge Voltage Low	40-143
Failure code [B@BAZG] Engine Oil Pressure Low	40-145
Failure code [B@BAZK] Eng Oil Level Low	40-146
Failure code [B@BCNS] Engine Coolant Overheat	40-147
Failure code [B@BCZK] Radiator Coolant Level Low	40-148
Failure code [B@HANS] Hyd Oil Overheat	40-150
Failure code [CA115] Eng Ne and Bkup Speed Sens Error	40-151
Failure code [CA122] Chg Air Press Sensor High Error	40-152
Failure code [CA123] Chg Air Press Sensor Low Error	40-154
Failure code [CA131] Throttle Sensor High Error	40-156
Failure code [CA132] Throttle Sensor Low Error	40-158
Failure code [CA144] Coolant Temp Sens High Error	40-160
Failure code [CA145] Coolant Temp Sens Low Error	40-162
Failure code [CA153] Chg Air Temp Sensor High Error	40-164
Failure code [CA154] Chg Air Temp Sensor Low Error	40-166
Failure code [CA187] Sensor 2 Supply Volt Low Error	40-168
Failure code [CA221] Ambient Press Sensor High Error	40-170
Failure code [CA222] Ambient Press Sensor Low Error	40-172
Failure code [CA227] Sensor 2 Supply Volt High Error	40-174
Failure code [CA234] Eng Overspeed	40-175
Failure code [CA238] Ne Speed Sensor Supply Volt Error	40-176
Failure code [CA239] Ne Speed Sens Supply Volt High Error	40-177
Failure code [CA271] IMV/PCV1 Short Error	40-178

Failure code [CA272] IMV/PCV1 Open Error	40-180
Failure code [CA295] Ambient Press Sens In Range Error.....	40-181
Failure code [CA322] Inj #1(L#1) Open/Short Error	40-182
Failure code [CA323] Inj #5(L#5) Open/Short Error	40-184
Failure code [CA324] Inj #3(L#3) Open/Short Error	40-186
Failure code [CA325] Inj #6(L#6) Open/Short Error	40-188
Failure code [CA331] Inj #2(L#2) Open/Short Error	40-190
Failure code [CA332] Inj #4(L#4) Open/Short Error	40-192
Failure code [CA343] ECM Critical Internal Failure.....	40-194
Failure code [CA351] Injectors Drive Circuit Error	40-195
Failure code [CA352] Sensor 1 Supply Volt Low Error	40-196
Failure code [CA356] Mass Air Flow Sensor High Error	40-198
Failure code [CA357] Mass Air Flow Sensor Low Error.....	40-200
Failure code [CA386] Sensor 1 Supply Volt High Error.....	40-202
Failure code [CA428] Water in Fuel Sensor High Error	40-203
Failure code [CA429] Water in Fuel Sensor Low Error	40-205
Failure code [CA435] Eng Oil Press Sw Error	40-207
Failure code [CA441] Battery Voltage Low Error	40-208
Failure code [CA442] Battery Voltage High Error.....	40-210
Failure code [CA449] Rail Press Very High Error.....	40-211
Failure code [CA451] Rail Press Sensor High Error.....	40-212
Failure code [CA452] Rail Press Sensor Low Error	40-214
Failure code [CA488] Chg Air Temp High Torque Derate.....	40-215
Failure code [CA515] Rail Press Sens Sup Volt High Error	40-216
Failure code [CA516] Rail Press Sens Sup Volt Low Error	40-218
Failure code [CA553] Rail Press High Error	40-220
Failure code [CA555] Crankcase Press High Error 1	40-221
Failure code [CA556] Crankcase Press High Error 2	40-222
Failure code [CA559] Rail Press Low Error.....	40-223
Failure code [CA595] Turbo Speed High Error 2	40-225
Failure code [CA687] Turbo Speed Low Error.....	40-226
Failure code [CA689] Eng Ne Speed Sensor Error.....	40-228
Failure code [CA691] Intake Air Temp Sens High Error.....	40-230
Failure code [CA692] Intake Air Temp Sens Low Error.....	40-232
Failure code [CA697] ECM Int Temp Sensor High Error	40-234
Failure code [CA698] ECM Int Temp Sensor Low Error.....	40-235
Failure code [CA731] Eng Bkup Speed Sens Phase Error	40-236
Failure code [CA778] Eng Bkup Speed Sensor Error.....	40-237
Failure code [CA1117] Persistent Data Lost Error.....	40-241
Failure code [CA1664] KDOC Malfunction.....	40-242
Failure code [CA1691] Regeneration Ineffective	40-244
Failure code [CA1695] Sensor 5 Supply Volt Low Error	40-246
Failure code [CA1696] Sensor 5 Supply Volt High Error.....	40-248
Failure code [CA1843] Crankcase Press Sens High Error.....	40-250
Failure code [CA1844] Crankcase Press Sens Low Error	40-252
Failure code [CA1879] KDPF Delta P Sensor High Error	40-254
Failure code [CA1881] KDPF Delta P Sensor Low Error	40-256
Failure code [CA1883] KDPF Delta P Sens In Range Error.....	40-258
Failure code [CA1921] KDPF Soot Load High Error 1.....	40-261
Failure code [CA1922] KDPF Soot Load High Error 2.....	40-263
Failure code [CA1942] Crankcase Press Sens In Range Error	40-268
Failure code [CA1993] KDPF Delta Pressure Low Error	40-269
Failure code [CA2185] Throt Sensor Sup Volt High Error	40-270
Failure code [CA2186] Throt Sensor Sup Volt Low Error.....	40-271
Failure code [CA2249] Rail Press Very Low Error	40-272
Failure code [CA2271] EGR Valve Pos Sens High Error	40-273
Failure code [CA2272] EGR Valve Pos Sens Low Error	40-275
Failure code [CA2288] Turbo Speed High Error 1.....	40-278
Failure code [CA2311] IMV Solenoid Error	40-279

Failure code [CA2349] EGR Valve Solenoid Open Error	40-280
Failure code [CA2353] EGR Valve Solenoid Short Error	40-282
Failure code [CA2357] EGR Differential Pressure	40-284
Failure code [CA2373] Exh Manifold Press. Sens Volt	40-285
Failure code [CA2374] Exhaust Manifold Press Sens Low Error	40-287
Failure code [CA2375] EGR Orifice Temp Sens High Error	40-289
Failure code [CA2376] EGR Orifice Temp Sens Low Error	40-291
Failure code [CA2381] KVGTT Pos Sens High Error	40-293
Failure code [CA2382] KVGTT Pos Sens Low Error	40-295
Failure code [CA2383] KVGTT Solenoid Open Error	40-297
Failure code [CA2386] KVGTT Solenoid Short Error	40-299
Failure code [CA2387] KVGTT Servo Error	40-301
Failure code [CA2554] Exh Manifold Press Sens In Range Error	40-302
Failure code [CA2555] Grid Htr Relay Volt Low Error	40-303
Failure code [CA2556] Grid Htr Relay Volt High Error	40-306
Failure code [CA2637] KDOC Face Plugging	40-308
Failure code [CA2639] Manual Stationary Regeneration Request	40-310
Failure code [CA2961] EGR Orifice Temp High Error 1	40-312
Failure code [CA2973] Chg Air Press Sensor In Range Error	40-313
Failure code [CA3133] KDPF Outlet Press Sens High Error	40-314
Failure code [CA3134] KDPF Outlet Press Sens Low Error	40-316
Failure code [CA3135] KDPF Outlet Press Sens In Range Error	40-318
Failure code [CA3251] DOC Inlet Temp High Error	40-321
Failure code [CA3253] KDOC Temp Error - Non Regeneration	40-324
Failure code [CA3254] KDOC Outlet Temp High Error 1	40-325
Failure code [CA3255] KDPF Temp Error - Non Regeneration	40-328
Failure code [CA3256] KDPF Outlet Temp High Error 1	40-329
Failure code [CA3311] KDOC Outlet Temp High Error 2	40-330
Failure code [CA3312] KDPF Outlet Temp High Error 2	40-331
Failure code [CA3313] KDOC Inlet Temp Sensor Low Error	40-333
Failure code [CA3314] KDOC Inlet Temp Sens High Error	40-336
Failure code [CA3315] KDOC Inlet Temp Sens In Range Error	40-340
Failure code [CA3316] KDOC Outlet Temp Sens Low Error	40-344
Failure code [CA3317] KDOC Outlet Temp Sens High Error	40-347
Failure code [CA3318] KDOC Inlet Temp Sens In Range Error	40-351
Failure code [CA3319] KDPF Outlet Temp Sens High Error	40-355
Failure code [CA3321] KDPF Outlet Temp Sens Low Error	40-359
Failure code [CA3322] KDPF Outlet Temp Sens In Range Error	40-362
Failure code [CA3419] Mass Air Flow Sensor Sup Volt High Error	40-366
Failure code [CA3421] Mass Air Flow Sensor Sup Volt Low Error	40-367
Failure code [CA3741] Rail Press Valve Trip Error	40-369
Failure code [D110KB] Battery Relay Output Voltage	40-370
Failure code [D19JKZ] Personal Code Relay Abnormality	40-372
Failure code [D811MC] KOMTRAX Error	40-375
Failure code [D862KA] GPS Antenna Open Circuit	40-376
Failure code [D8ALKA] Operating Lamp Open Circuit(KOMTRAX)	40-377
Failure code [D8ALKB] Operating Lamp Short Circuit (KOMTRAX)	40-379
Failure code [D8AQKR] CAN2 Discon (KOMTRAX)	40-380
Failure code [DA20MC] Pump Controller	40-381
Failure code [DA22KK] Pump Solenoid Power Low Error	40-382
Failure code [DA25KP] 5V Sensor 1 Power Abnormality	40-384
Failure code [DA29KQ] Model Selection Abnormality	40-387
Failure code [DA2LKA] Operating Lamp Open Circuit(Pump Con)	40-389
Failure code [DA2LKB] Operating Lamp Short Circuit(Pump Con)	40-391
Failure code [DA2QKR] CAN2 Discon (Pump Con)	40-392
Failure code [DA2QKR] CAN1 Discon (Pump Con)	40-394
Failure code [DAF0MB] Monitor ROM Abnormality	40-395
Failure code [DAF0MC] Monitor Error	40-396

Failure code [DAF8KB] Camera Power Supply Short Circuit	40-397
Failure code [DAF9KQ] Model Selection Abnormality	40-399
Failure code [DAFGMC] GPS Module Error	40-400
Failure code [DAFLKA] Operating Lamp Open Circuit(Monitor)	40-401
Failure code [DAFLKB] Operating Lamp Short Circuit(Monitor)	40-403
Failure code [DAFQKR] CAN2 Discon (Monitor)	40-404
Failure code [DAZ9KQ] A/C Model Selection Abnormality	40-405
Failure code [DAZQKR] CAN2 Discon (Aircon ECU)	40-406
Failure code [DB2QKR] CAN2 Discon (Engine Con)	40-410
Failure code [DB2RKR] CAN1 Discon (Engine Con)	40-415
Failure code [DGH2KB] Hyd Oil Sensor Short Circuit	40-419
Failure code [DHA4KA] Air Cleaner Clog Sensor Open Circuit	40-421
Failure code [DHPAMA] F Pump Press Sensor Abnormality	40-422
Failure code [DHPBMA] R Pump Press Sensor Abnormality	40-425
Failure code [DHS3MA] Arm Curl PPC Press Sensor Abnormality	40-428
Failure code [DHS4MA] Bucket Curl PPC Press Sensor Abnormality	40-430
Failure code [DHS8MA] Boom Raise PPC Press Sensor Abnormality	40-433
Failure code [DHS9MA] Boom Lower PPC Press Sensor Abnormality	40-436
Failure code [DHSAMA] Swing RH PPC Press Sensor Abnormality	40-439
Failure code [DHSBMA] Swing LH PPC Press Sensor Abnormality	40-442
Failure code [DHSCMA] Arm Dump PPC Press Sensor Abnormality	40-445
Failure code [DHSDMA] Bucket Dump PPC Press Sensor Abnormality	40-448
Failure code [DHSFMA] Travel Fwd LH PPC Press Sensor Abnormality	40-451
Failure code [DHSGMA] Travel Fwd RH PPC Press Sensor Abnormality	40-454
Failure code [DHSHMA] Travel Rev LH PPC Press Sensor Abnormality	40-457
Failure code [DHSJMA] Travel Rev RH PPC Press Sensor Abnormality	40-460
Failure code [DKR0MA] F Pump Swash Plate Sensor Abnormality	40-463
Failure code [DKR1MA] R Pump Swash Plate Sensor Abnormality	40-466
Failure code [DR21KX] Camera 2 Picture Rev. Drive Abnormality	40-469
Failure code [DR31KX] Camera 3 Picture Rev. Drive Abnormality	40-471
Failure code [DV20KB] Travel Alarm Short Circuit	40-473
Failure code [DW43KA] Travel Speed Sol Open Circuit	40-475
Failure code [DW43KB] Travel Speed Sol Short Circuit	40-477
Failure code [DW45KA] Swing Brake Sol Open Circuit	40-479
Failure code [DW45KB] Swing Brake Sol Short Circuit	40-482
Failure code [DW91KA] Travel Junction Sol Open Circuit	40-485
Failure code [DW91KB] Travel Junction Sol Short Circuit	40-487
Failure code [DWA2KA] Attachment Sol Open Circuit	40-489
Failure code [DWA2KB] Attachment Sol Short Circuit	40-491
Failure code [DWK0KA] 2-Stage Relief Sol Open Circuit	40-493
Failure code [DWK0KB] 2-Stage Relief Sol Short Circuit	40-495
Failure code [DWK2KA] Variable Back Press Sol Open Circuit	40-497
Failure code [DWK2KB] Variable Back Press Sol Short Circuit	40-499
Failure code [DWK8KA] Swing Press C/O Sol Open Circuit	40-501
Failure code [DWK8KB] Swing Press C/O Sol Short Circuit	40-503
Failure code [DXA8KA] PC-EPC (F) Sol Open Circuit	40-505
Failure code [DXA8KB] PC-EPC (F) Sol Short Circuit	40-507
Failure code [DXA9KA] PC-EPC (R) Sol Open Circuit	40-509
Failure code [DXA9KB] PC-EPC (R) Sol Short Circuit	40-511
Failure code [DXE0KA] LS-EPC Sol Open Circuit	40-513
Failure code [DXE0KB] LS-EPC Sol Short Circuit	40-515
Failure code [DXE4KA] Attachment Flow EPC Open Circuit	40-517
Failure code [DXE4KB] Attachment Flow EPC Short Circuit	40-519
Failure code [DXE5KA] Merge-divide Main Sol Open Circuit	40-521
Failure code [DXE5KB] Merge-divide Main Sol Short Circuit	40-523
Failure code [DXE6KA] Merge-divide LS Sol Open Circuit	40-525
Failure code [DXE6KB] Merge-divide LS Sol Short Circuit	40-527
Failure code [DY20KA] Wiper Working Abnormality	40-529
Failure code [DY20MA] Wiper Parking Abnormality	40-531

Failure code [DY2CKB] Washer Drive Short Circuit	40-533
Failure code [DY2DKB] Wiper Drive (Fwd) Short Circuit	40-535
Failure code [DY2EKB] Wiper Drive (Rev) Short Circuit	40-537
Troubleshooting of electrical system (E-mode)	40-539
E-1 Engine does not start (Engine does not rotate).....	40-539
E-2 Manual preheating system does not work.....	40-545
E-3 Automatic preheating system does not work.....	40-548
E-4 Preheating monitor does not light up when preheater is operated	40-550
E-5 When starting switch is turned to ON position, machine monitor displays nothing.....	40-552
E-6 When starting switch is turned to ON position (before starting engine), engine oil level monitor lights up in yellow.....	40-555
E-7 When starting switch is turned to ON position (before starting engine), radiator coolant level monitor lights up in yellow	40-556
E-8 Coolant temperature monitor lights up in white while engine is running	40-557
E-9 Hydraulic oil temperature monitor lights up in white while engine is running	40-558
E-10 Charge level monitor lights up while engine is running	40-559
E-11 Fuel level monitor lights up in red while engine is running.....	40-560
E-12 Air cleaner clogging monitor lights up in yellow while engine is running	40-561
E-13 Water separator monitor lights up while engine is running	40-562
E-14 Coolant temperature monitor lights up in red while engine is running.....	40-563
E-15 Hydraulic oil temperature monitor lights up in red while engine is running	40-564
E-16 Engine oil pressure monitor lights up in red while engine is running	40-565
E-17 Fuel gauge indicate either full or empty and does not move.....	40-566
E-18 Fuel gauge indicates incorrect amount (indicates neither full nor empty).....	40-567
E-19 Coolant temperature gauge indicate either Min or Max and does not move.....	40-568
E-20 Coolant temperature gauge indicates incorrect temperature (indicates neither Min nor Max)	40-569
E-21 Hydraulic oil temperature gauge indicate either Min or Max and does not move	40-570
E-22 Hydraulic oil temperature gauge indicates incorrect temperature (indicates neither Min nor Max)	40-572
E-23 Content of display on machine monitor is different from that of actual machine	40-573
E-24 Machine monitor does not display some items	40-574
E-25 Function switch does not work.....	40-575
E-26 Automatic preheating system does not work (In cold season).....	40-576
E-27 Auto-deceleration monitor does not light up or does not go out when auto-deceleration switch is operated	40-577
E-28 Auto-deceleration is not actuated or canceled when lever is operated	40-578
E-29 Working mode selector screen selection screen is not displayed when working mode switch is operated	40-580
E-30 Engine or hydraulic pump setting does not change when working mode is changed.....	40-581
E-31 Travel speed monitor does not change when travel speed switch is operated	40-582
E-32 Travel speed does not change when travel speed is shifted	40-583
E-33 Alarm buzzer does not stop sounding.....	40-584
E-34 When starting switch is turned to OFF position, service meter is not displayed.....	40-585
E-35 Service mode cannot be selected	40-586
E-36 Any of work equipment, swing and travel does not work.....	40-587
E-37 Any of work equipment, swing and travel can not be locked	40-589
E-38 Machine can not swing while swing brake cancel switch is canceled.....	40-590
E-39 Swing brake does not operate while swing brake cancel switch is locked	40-592
E-40 One-touch power maximizing function does not work or monitor is not displayed	40-594
E-41 One-touch power maximizing function cannot be released	40-596
E-42 Travel alarm does not sound when machine travels.....	40-597
E-43 Travel alarm does not stop sounding when machine stops	40-598
E-44 Horn does not sound	40-599
E-45 Horn does not stop sounding.....	40-601
E-46 Wiper monitor does not light up or go out when wiper switch is operated	40-602
E-47 Wiper does not operate when wiper switch is operated	40-603

E-49 BOOM LOWER indication is not displayed properly with monitoring function	40-606
E-50 ARM DUMP indication is not displayed properly with monitoring function	40-607
E-51 ARM IN indication is not displayed properly with monitoring function	40-608
E-52 BOOM RAISE indication is not displayed properly with monitoring function	40-609
E-53 BUCKET CURL indication is not displayed properly with monitoring function	40-610
E-54 BUCKET DUMP indication is not displayed properly with monitoring function	40-611
E-55 SWING indication is not displayed properly with monitoring function	40-612
E-56 TRAVEL indication is not displayed properly with monitoring function	40-613
E-57 Service is not displayed properly with monitoring function	40-614
E-58 Attachment hydraulic circuit cannot be changed	40-617
E-59 KOMTRAX system does not work properly	40-618
Troubleshooting of hydraulic and mechanical system (H-mode)	40-619
Information mentioned in troubleshooting table (H mode)	40-619
System chart for hydraulic system	40-620
Failure mode and cause table	40-622
H-1 All of work equipment, swing and travel operation lacks speed or power	40-630
H-2 Engine speed lowers significantly or engine stalls	40-633
H-3 Any of work equipment, swing and travel does not work	40-635
H-4 Unusual sound is heard from around hydraulic pump	40-636
H-5 Fine control performance or response is poor	40-637
H-6 Boom operation lacks speed or power	40-638
H-7 Arm operation lacks speed or power	40-640
H-8 Bucket operation lacks speed or power	40-642
H-9 Work equipment does not move in single operation	40-643
H-10 Hydraulic drift of boom is large	40-644
H-11 Hydraulic drift of arm is large	40-645
H-12 Hydraulic drift of bucket is large	40-646
H-13 Time lag of work equipment is large	40-647
H-14 When part of work equipment is relieved singly, other parts of work equipment move	40-649
E-15 One-touch power maximizing function does not work	40-650
H-16 In combined operation of work equipment, equipment having heavier load moves slower	40-651
H-17 In combined operations of swing and boom RAISE, boom rising speed is low	40-652
H-18 In combined operations of swing and travel, travel speed drops largely	40-653
H-19 Machine does not travel straight	40-654
H-20 Travel speed is too low	40-655
H-21 Machine is hard to steer or travel power is low	40-657
H-22 Travel speed does not change, or travel speed is too low or high	40-659
H-23 One of tracks dose not run	40-660
H-24 Upper structure does not swing to the right or left	40-661
H-25 Upper structure swing only to the right or left	40-662
H-26 Swing acceleration is poor or swing speed is low (both right and left)	40-663
H-27 Swing acceleration is poor or swing speed is low (either right or left)	40-664
H-28 Upper structure overruns excessively when it stops swinging (both right and left)	40-665
H-29 Upper structure overruns excessively when it stops swinging (either right or left)	40-666
H-30 Shock is large when upper structure stops swinging	40-667
H-31 Large unusual noise is heard when upper structure stops swinging	40-668
H-32 Swing drift on a slope is large while swing holding brake is applied	40-669
H-33 Swing drift on a slope is large while swing holding brake is released	40-670
H-34 Attachment circuit cannot be changed while attachment is installed	40-671
H-35 Oil flow in attachment circuit cannot be controlled	40-672
Troubleshooting of engine (S-mode)	40-673
Information mentioned in troubleshooting table (S mode)	40-673
S-1 When starting switch is turned to START position, engine does not crank	40-674
S-2 When engine cranks, smoke does not come out	40-675
S-3 Engine does not start while fuel is injected (Incomplete combustion)	40-676
S-4 Startability is poor	40-677

S-5 Engine does not pick up smoothly	40-679
S-6 Engine stops during operation	40-680
S-7 Engine runs rough or is unstable	40-682
S-8 Engine lacks power	40-683
S-9 Exhaust smoke is black (KDPF clogs up early)	40-685
S-10 Engine oil consumption is too much	40-687
S-11 Oil becomes contaminated early	40-688
S-12 Fuel consumption is excessive	40-689
S-13 Oil is in coolant (or coolant spurts or coolant level goes down).....	40-690
S-14 Engine oil pressure drops	40-691
S-15 Fuel is contaminated in engine oil	40-692
S-16 Coolant is contaminated in engine oil (Oil becomes cloudy white).....	40-693
S-17 Coolant temperature rises too high (Overheating)	40-694
S-18 Unusual noise is heard	40-695
S-19 Vibration is excessive	40-696
S-20 Automatic regeneration is operated frequently	40-697
S-21 Active regeneration is operated for long	40-698
S-22 White smoke comes out in the process of active regeneration	40-699
50 Disassembly and assembly	50-1
Table of contents	50-2
General information on disassembly and assembly.....	50-4
How to read this manual	50-4
Coating materials list	50-6
Special tools list	50-10
Sketches of special tools	50-18
Engine and cooling system.....	50-21
Removal and installation of supply pump assembly.....	50-21
Removal and installation of injector assembly.....	50-26
Removal and installation of cylinder head assembly.....	50-35
Removal and installation of radiator assembly	50-55
Removal and installation of hydraulic oil cooler assembly	50-57
Removal and installation of aftercooler assembly.....	50-60
Removal and installation of engine and main pump assembly	50-62
Removal and installation of engine front oil seal.....	50-74
Removal and installation of engine rear oil seal.....	50-78
Removal and installation of fuel cooler assembly	50-81
Removal and installation of fuel tank assembly	50-82
Removal and installation of engine hood assembly	50-85
Removal and installation of KDPF assembly.....	50-88
Disassembly and assembly of KDPF	50-96
Removal and installation of KCCV assembly	50-104
Removal and installation of air cleaner assembly	50-107
Power train.....	50-110
Removal and installation of travel motor and final drive assembly.....	50-110
Disassembly and assembly of final drive	50-112
Removal and installation of swing motor and swing machinery assembly	50-120
Disassembly and assembly of swing machinery.....	50-123
Removal and installation of swing circle assembly	50-131
Undercarriage and frame.....	50-132
Separation and connection of track shoe assembly	50-132
Removal and installation of sprocket.....	50-135
Removal and installation of idler and idler cushion assembly	50-136
Disassembly and assembly of idler.....	50-137
Disassembly and assembly of idler cushion.....	50-140
Disassembly and assembly of track roller	50-142
Disassembly and assembly of carrier roller.....	50-145
Removal and installation of revolving frame assembly	50-148
Removal and installation of counterweight assembly.....	50-150
Hydraulic system	50-153

Removal and installation of center swivel joint assembly	50-153
Disassembly and assembly of center swivel joint	50-155
Removal and installation of hydraulic tank assembly	50-157
Removal and installation of main pump assembly	50-161
Removal and installation of control valve assembly	50-165
Disassembly and assembly of control valve	50-172
Disassembly and assembly of work equipment PPC valve	50-177
Disassembly and assembly of travel PPC valve	50-179
Work equipment	50-182
Removal and installation of work equipment assembly	50-182
Disassembly and assembly of work equipment cylinder	50-185
Cab and its attachments	50-191
Removal and installation of operator's cab assembly	50-191
Removal and installation of operator cab glass (adhered glass)	50-196
Removal and installation of front window assembly	50-206
Removal and installation of floor frame assembly	50-212
Removal and installation of air conditioner unit assembly	50-218
Removal and installation of operator's seat	50-222
Removal and installation of seat belt	50-224
Removal and installation of front wiper assembly	50-226
Electric system	50-233
Removal and installation of air conditioner compressor assembly	50-233
Removal and installation of air conditioner condenser assembly	50-236
Removal and installation of engine controller assembly	50-238
Removal and installation of pump controller assembly	50-240
Removal and installation of machine monitor assembly	50-243
Removal and installation of pump swash plate sensor	50-245
Removal and installation of Mass air flow and temperature sensor	50-246
Removal and installation of KOMTRAX terminal assembly	50-247
60 Maintenance standard	60-1
Table of contents	60-2
Engine and cooling system	60-3
Engine mount	60-3
Cooling system	60-4
Power train	60-5
Swing circle	60-5
Swing machinery	60-6
Final drive	60-8
Sprocket	60-10
Undercarriage and frame	60-12
Truck frame and idler cushion	60-12
Idler	60-14
Truck roller	60-16
Carrier roller	60-17
Truck shoe	60-18
Hydraulic system	60-23
Hydraulic tank	60-23
Main pump	60-24
Control valve	60-25
Swing motor	60-33
Travel motor	60-35
PPC valve	60-38
Solenoid valve	60-48
Attachment circuit selector valve (for high-pressure circuit)	60-49
Attachment circuit selector valve (for low-pressure circuit)	60-50
Center swivel joint	60-51
Work equipment	60-52
Work equipment cylinder	60-52
80 Appendix	80-1

Table of contents	80-2
Air conditioner	80-3
Precautions for refrigerant.....	80-3
Air conditioner component	80-4
Structure and function of refrigeration system	80-6
Overview of refrigeration system	80-7
Air conditioner unit	80-9
Dual pressure switch	80-15
Air conditioner controller	80-16
Air conditioner compressor	80-17
Air conditioner condenser	80-18
Sunlight sensor.....	80-20
Outside air temperature sensor	80-21
Inspection and troubleshooting procedure of air conditioner.....	80-22
Air conditioner circuit diagram and arrangement of connector pins.....	80-24
System diagram.....	80-26
Air conditioner controller input and output signals.....	80-27
Parts and connectors layout.....	80-29
Layout of air conditioner related parts and connectors	80-30
Testing air leakage (duct).....	80-33
Testing with self-diagnosis function.....	80-36
How to enter air conditioner "Electrical Systems" screen in service mode of the machine monitor.....	80-37
Testing vent (mode) changeover.....	80-39
Testing FRESH/RECIRC air changeover.....	80-41
Testing sunlight sensor	80-42
Testing (dual) pressure switch for refrigerant.....	80-43
Testing relay	80-45
Troubleshooting chart 1	80-46
Troubleshooting chart 2	80-47
Information mentioned in troubleshooting table	80-50
Failure code list related to air conditioner.....	80-51
Failure code [879AKA] A/C Inner Sensor Open Circuit	80-53
Failure code [879AKB] A/C Inner Sensor Short Circuit.....	80-54
Failure code [879BKA] A/C Outer Sensor Open Circuit.....	80-55
Failure code [879BKB] A/C Outer Sensor Short Circuit.....	80-57
Failure code [879CKA] Ventilating Sensor Open Circuit.....	80-59
Failure code [879CKB] Ventilating Sensor Short Circuit.....	80-60
Failure code [879DKZ] Sunlight Sensor Open or Short Circuit.....	80-61
Failure code [879EMC] Ventilation Damper Abnormality	80-63
Failure code [879FMC] Air Mix Damper Abnormality	80-64
Failure code [879GKX] Refrigerant Abnormality.....	80-65
A-1 Troubleshooting for power supply system (The air conditioner does not operate).....	80-66
A-2 Troubleshooting of compressor system (Air is not cooled).....	80-68
A-3 Troubleshooting of blower motor system (Air does not come out or air flow is abnormal)	80-71
A-4 Troubleshooting for FRESH/RECIRC air changeover	80-73
Troubleshooting with gauge pressure.....	80-75
Testing refrigerant pressure.....	80-77
Precautions for disconnecting and connecting refrigerant piping.....	80-80
Filling compressor oil.....	80-82
Desiccant replacement	80-84
90 Diagrams and drawings	90-1
Table of contents	90-2
Hydraulic circuit diagram	90-3
Symbols in hydraulic circuit diagram	90-3
Hydraulic circuit diagram.....	90-7
Electric circuit diagram	90-11
Symbols in electric circuit diagram	90-11

Electric circuit diagram.....	90-15
Electric circuit diagram for air conditioner unit	90-27
Index.....	1

Foreword, safety and general information

Important safety notice

(Rev. 2010/09)

- Appropriate servicing and repair are extremely important to ensure safe operation of the machine. The Shop Manual describes the effective and safe servicing and repair methods recommended by KOMATSU. Some of these methods require the use of tools specially designed by KOMATSU for the specific purpose.
- The symbol mark  is used for such matters that require special precautions during the work. The work indicated with this warning mark should be performed according to the instructions with special attention to the precautions. Should a hazardous situation occur or be anticipated during such work, be sure to keep safe first and take every necessary measure.

General precautions

 **Inappropriate handling creates an extreme danger. Read and understand what is described in the Operation and Maintenance Manual before operating the machine. In addition, read this manual carefully and understand its contents before starting work.**

- Before performing any greasing or repairs, read all the safety labels stuck to the machine. For the locations of the safety labels and detailed explanation of precautions, see the Operation and Maintenance Manual.
- Locate a place in the repair workshop to keep tools and removed parts. Always keep the tools and parts in their correct places. Always keep the work area clean and make sure that there is no dirt, water, or oil on the floor. Smoke only in the areas provided for smoking. Never smoke while working.
- When performing any work, always wear safety shoes and a helmet. Do not wear loose work clothes, or clothes with buttons missing.
 1. Always wear the protective eyeglasses when hitting parts with a hammer.
 2. Always wear the protective eyeglasses when grinding parts with a grinder, etc.
- When performing any work with two or more workers, always agree on the operating procedure before starting. Always inform your fellow workers before starting any step of the work. During the work, hang UNDER REPAIR warning tag in the operator's compartment.
- Only qualified workers must perform the work and operation which require license or qualification.
- Keep all tools in good condition. Learn the correct way to use them, and use the proper ones of them. Before starting work, thoroughly check the tools, machine, forklift truck, service car, etc.
- If welding repairs are needed, always have a trained and experienced welder perform the work. When performing welding work, always

wear welding gloves, apron, shielding goggles, cap and other clothes suited for welding work.

- Before starting work, warm up your body thoroughly to start work under good condition.
- Avoid continuing work for long hours and take rests at proper intervals to keep your body in good condition. Take rests in specified safe places.

Safety points

1	Good arrangement
2	Correct work clothes
3	Following work standard
4	Making and checking signals
5	Prohibition of operation and handling by unlicensed workers
6	Safety check before starting work
7	Wearing protective goggles (for cleaning or grinding work)
8	Wearing shielding goggles and protectors (for welding work)
9	Good physical condition and preparation
10	Precautions against work which you are not used to or you are used to too much

Preparation work

- Before adding oil or making any repairs, park the machine on a hard and level ground, and apply the parking brake and chock the wheels or tracks to prevent the machine from moving.
- Before starting work, lower the work equipment (blade, ripper, bucket, etc.) to the ground. If this is not possible, insert the lock pin or use blocks to prevent the work equipment from falling. In addition, be sure to lock all the control levers and hang warning tag on them.
- When disassembling or assembling, support the machine with blocks, jacks, or stands before starting the work.
- Remove all mud and oil from the steps or other places used to get on and off the machine. Always use the handrails, ladders or steps when getting on or off the machine. Never jump on or off the machine. When a scaffolding is not

provided, use steps or a step ladder to secure your footing.

Precautions during work

- For the machine equipped with a battery disconnect switch, before starting the work, check that the system operating lamp is turned OFF, and then turn the battery disconnect switch to the "OFF(○)" position and pull the switch key out. For the machine without a battery disconnect switch, before starting the work, remove the cables from the battery. Always remove the cable from the negative (–) terminal first.
- Before disconnecting or removing components of the oil, fuel, water, or air circuits, first release the remaining pressure completely from the circuit. When removing the oil filler cap, a drain plug, or an oil pressure pickup plug, loosen it slowly to prevent the oil from spurting out.
- When removing and installing fuel system inspection plugs and piping, shut down the engine and wait for 30 seconds until the remaining pressure is released.
- The coolant and oil in the circuits are hot when the engine is shut down. Be careful not to get scalded. Wait for the oil and coolant to cool before performing any work on the oil or water circuits.
- Before starting work, shut down the engine. When working on or around a rotating part, in particular, shut down the engine. When checking the machine without stopping the engine (measuring oil pressure, revolving speed, temperature, etc.), take extreme care not to get rolled or caught in rotating parts or moving parts.
- When raising a heavy component (heavier than 25 kg), use a hoist or crane. Before starting work, check that the slings (wire ropes, chains, and hooks) are free from damage. Always use slings which have ample capacity and install them to proper places. Operate the hoist or crane slowly to prevent the component from hitting any other part. Do not work with any part still raised by the hoist or crane.
- When removing a cover which is under internal pressure or under reaction force of a spring, always leave two bolts in diagonal positions. Loosen those two bolts gradually and alternately to release the pressure, and then remove the cover.
- When removing components, be careful not to break or damage the electrical wiring. Damaged wiring may cause electrical fires.
- When removing piping, stop the fuel or oil from spilling out. If any fuel or oil drips onto the floor, wipe it off immediately. Fuel or oil on the floor can cause you to slip and can even cause fires.
- As a general rule, do not use gasoline to wash parts. Do not use it to clean electrical parts, in particular.
- Be sure to assemble all parts again in their original places. Replace any damaged parts and parts which must not be reused with new parts. When installing hoses and wires, be sure that they will not be damaged by contact with other parts when the machine is operated.
- When installing high-pressure hoses and tubes, make sure that they are not twisted. Damaged hoses and tubes are dangerous, so be extremely careful when installing hoses and tubes for high-pressure circuits. In addition, check that connections of them are correct.
- When assembling or installing parts, always tighten them to the specified torques. When installing protective parts such as guards, or parts which vibrate violently or rotate at high speeds, be particularly careful to check that they are installed correctly.
- When aligning two holes, never insert your fingers or hand. Be careful not to get your fingers caught in a hole.
- When measuring hydraulic pressure, check that the measuring tools are correctly installed.
- Take care when removing or installing the tracks of track-type machines. When removing the track, the track separates suddenly, so never let anyone stand at either end of the track.
- If the engine is operated for a long time in a place which is not ventilated well, you may suffer from gas poisoning. Accordingly, open the windows and doors to ventilate well.

Precautions for slinging work and making signals

- Only one appointed worker must make signals and co-workers must communicate with each other frequently. The appointed signaler must make specified signals clearly at a place where he (she) is well seen from the operator's seat and where he (she) can see the working condition easily. The signaler must always stand in front of the load and guide the operator safely
 1. Do not stand under the load.
 2. Do not step on the load.
- Check the slings before starting sling work.
- Keep putting on gloves during sling work. (Put on leather gloves, if available.)
- Measure the weight of the load by the eye and check its center of gravity.
- Use proper sling according to the weight of the load and method of slinging. If too thick wire ropes are used to sling a light load, the load may slip and fall.
- Do not sling a load with one wire rope alone. If it is slung by one wire rope, it may rotate and slip

out of the rope. Install two or more wire ropes symmetrically.

⚠ Slinging with one rope may cause turning of the load during hoisting, untwisting of the rope, or slipping of the rope from its original winding position on the load, which can result in a dangerous accident.

- Limit the hanging angle to 60 degree, as a rule.
- Do not sling a heavy load (25 kg or more) with ropes forming a wide hanging angle from the hook.
- ★ When hoisting a load with two or more ropes, the force subjected to each rope will increase with the hanging angle. The figure below shows the variation of allowable load in kN {kg} when hoisting is made with two ropes, each of which is allowed to sling up to 9.8 kN {1,000 kg} vertically, at various hanging angles. When the two ropes sling a load vertically, up to 19.6 kN {2,000 kg} of total weight can be suspended. This weight is reduced to 9.8 kN {1,000 kg} when the two ropes make a hanging angle of 120 degree. If the two ropes sling a 19.6 kN {2,000 kg} load at a lifting angle of 150 degree, each rope is subjected to a force as large as 39.2 kN {4,000 kg}

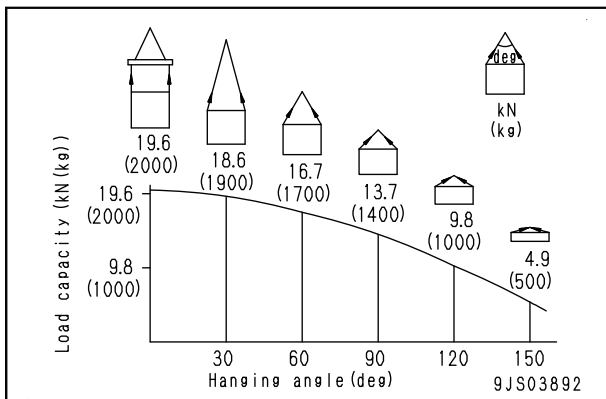

- When installing wire ropes to an angular load, apply pads to protect the wire ropes. If the load is slippery, apply proper material to prevent the wire rope from slipping.
- Use the specified eyebolts and fix wire ropes, chains, etc. to them with shackles, etc.
- Apply wire ropes to the middle portion of the hook.
- ★ Slinging near the tip of the hook may cause the rope to slip off the hook during hoisting. The hook has the maximum strength at the middle part.

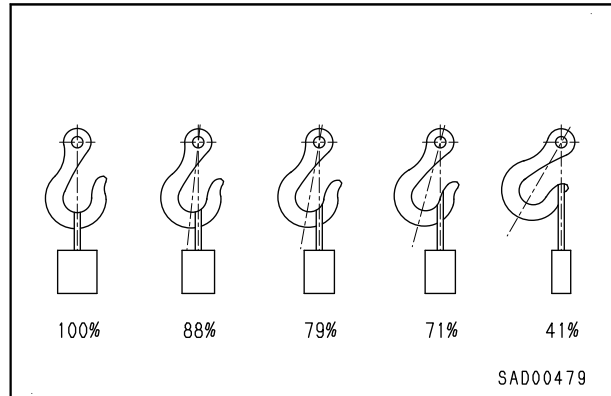

- Do not use twisted or kinked wire ropes.
- When lifting a load, observe the following.
 1. Wind in the crane slowly until wire ropes are stretched. When settling the wire ropes with the hand, do not grasp them but press them from above. If you grasp them, your fingers may be caught.
 2. After the wire ropes are stretched, stop the crane and check the condition of the slung load, wire ropes, and pads.
 3. If the load is unstable or the wire rope or chains are twisted, lower the load and lift it up again.
 4. Do not lift up the load at an angle.
- When lowering a load, observe the following.
 1. When lifting down a load, stop it temporarily at 30 cm above the floor, and then lower it slowly.
 2. Check that the load is stable, and then remove the sling.
 3. Remove kinks and dirt from the wire ropes and chains used for the sling work, and put them in the specified place.

Precautions for using mobile crane

- ★ Read the Operation and Maintenance Manual of the crane carefully in advance and operate the crane safely.

Precautions for using overhead traveling crane

⚠ When raising a heavy part (heavier than 25 kg), use a hoist, etc. In disassembly and assembly, the weight of a part heavier than 25 kg is indicated after the mark of .

- Before starting work, inspect the wire ropes, brake, clutch, controller, rails, over wind stop device, ground fault circuit interrupter, crane collision prevention device, and power application warning lamp, and check safety.
- Observe the signals for sling work.
- Operate the hoist at a safe place.
- Check the direction indicator plates (north, south, east and west) and the directions of the control buttons without fail.

- Do not sling a load at an angle. Do not move the crane while the slung load is swinging.
- Do not raise or lower a load while the crane is moving longitudinally or laterally.
- Do not drag a sling.
- When lifting a load, stop it just after it leaves the ground and check safety, and then lift it up.
- Consider the travel route in advance and lift up a load to a safe height.
- Place the control switch in a position where it will not be an obstacle to work and passage.
- After operating the hoist, do not swing the control switch.
- Remember the position of the main switch so that you can turn off the power immediately in an emergency.
- If the hoist stops because of a power failure, turn the power switch OFF. When turning on a switch which was turned OFF by the ground fault circuit interrupter, check that the devices related to that switch are not in operating condition.
- If you find an obstacle around the hoist, stop the operation.
- After finishing the work, stop the hoist at the specified position and raise the hook to at least two meters above the floor. Do not leave the sling attached to the hook.

Selecting wire ropes

- Select adequate ropes depending on the weight of parts to be hoisted, referring to the table below

Wire ropes (Standard “Z” twist ropes without galvanizing) (JIS G3525, No. 6, Type 6x37-A)

Nominal diameter of rope	Allowable load	
	kN	ton
mm		
10	8.8	0.9
12	12.7	1.3
14	17.3	1.7
16	22.6	2.3
18	28.6	2.9
20	35.3	3.6
25	55.3	5.6
30	79.6	8.1
40	141.6	14.4
50	221.6	22.6
60	318.3	32.4

- ★ The allowable load is one-sixth of the breaking strength of the rope to be used (Safety factor: 6).

Precautions for disconnecting and connecting hoses and tubes in air conditioner circuit

Disconnection

⚠ Although the refrigerant (refrigerant gas: R134a) used on the machine's air conditioner is less destructive to the ozone layer for environmental friendliness, it is not allowed to be released into the atmosphere as is. Whenever disconnecting the air conditioner gas circuit, be sure to recover the refrigerant gas to reuse it.

- ★ Ask a qualified person for collection and charge of the refrigerant (R134a).
- ★ Never release refrigerant (R134a) to the atmosphere.

⚠ If refrigerant gas (R134a) gets in your eyes, you may lose your sight. And if it touches your skins, you may suffer from frostbite. Accordingly, put on the protective eyeglasses, gloves and working suits with long sleeves while you are collecting or filling the refrigerant (R134a).

- When loosening the nuts fixing air conditioner hoses and tubes, be sure to use two wrenches; use one wrench to fix and use the other one to loosen the nut.

Connection

- When installing the air conditioner hoses and tubes, take care to prevent any dirt, dust or water from entering.
- When installing the air conditioner hoses and tubes, check that O-rings are fitted to their joints.
- Once an O-ring is used, it is deformed and deteriorated. Accordingly, do not reuse it.
- When removing the O-ring, use a soft tool so that the piping will not be damaged.
- Check that there is no defect or deterioration on the O-ring.
- Apply compressor oil for refrigerant (R134a) to the O-ring.

- ★ However, do not apply oil to the threads portion of a bolt, nut or union.

Manufacturer	Part Name
DENSO	ND-OIL8
VALEO THERMAL SYSTEMS	ZXL100PG (equivalent to PAG46)
SANDEN	SP-10

- When tightening nuts of the air conditioner hoses and tubes, be sure to use two wrenches. Use one wrench to fix and tighten the nut with the other wrench to the specified torque (Use a torque wrench for tightening).

00 Index and foreword

Foreword, safety and general information

★ Example of fitting of O-ring

- An O-ring is fitted to every joint of hoses and tubes in the air conditioner circuit.

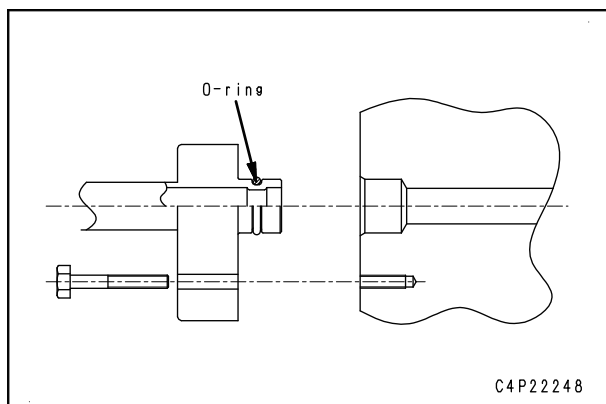
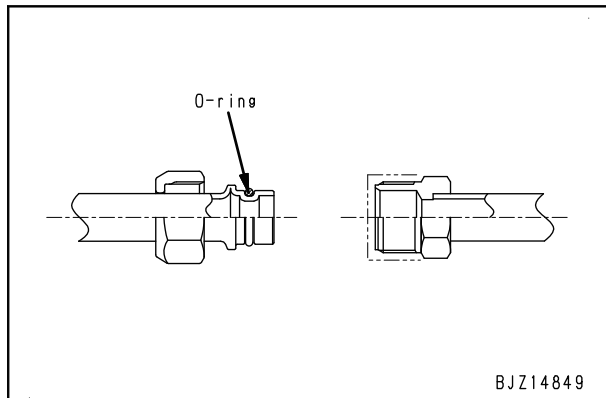

- ★ For tightening torque, see "Others", "Precautions for disconnection and connection of air conditioner piping".