

# SHOP MANUAL

## KOMATSU

# PC200,210-3 PC220,240-3

MACHINE MODEL

SERIAL No.

PC200,200LC-3

20001 and up

PC210,210LC-3K

K10001 and up

PC220,220LC-3

20001 and up

PC240,240LC,240NLC-3

10001 and up

PC240,240LC,240NLC-3K

K10001 and up

**NOTE:**

Please correct the information regarding the applicability of pages 11-1 and following as follows:

Present	Revised
PC200-3 21464 and up	<ul style="list-style-type: none"><li>● PC200-3 21464 and up</li><li>● PC210-3</li></ul>
PC220-3 26365 and up	<ul style="list-style-type: none"><li>● PC220-3 26365 and up</li><li>● PC240-3</li></ul>

# CONTENTS

	No. of page
<b>01 GENERAL</b> .....	01-1
<b>10 ENGINE</b>	
11 STRUCTURE AND FUNCTION .....	11-1
12 TESTING AND ADJUSTING .....	12-1
13 DISASSEMBLY AND ASSEMBLY .....	13-1
<b>20 POWER TRAIN</b>	
21 STRUCTURE AND FUNCTION .....	21-1
22 TESTING AND ADJUSTING .....	22-1
23 DISASSEMBLY AND ASSEMBLY .....	23-1
24 MAINTENANCE STANDARD .....	24-1
<b>30 UNDERCARRIAGE</b>	
31 STRUCTURE AND FUNCTION .....	31-1
33 DISASSEMBLY AND ASSEMBLY .....	33-1
34 MAINTENANCE STANDARD .....	34-1
<b>60 HYDRAULIC SYSTEM</b>	
61 STRUCTURE AND FUNCTION .....	61-1
62 TESTING AND ADJUSTING .....	62-1
63 DISASSEMBLY AND ASSEMBLY .....	63-1
64 MAINTENANCE STANDARD .....	64-1
<b>80 ELECTRIC AND ELECTRONIC SYSTEM</b>	
81 STRUCTURE AND FUNCTION .....	81-1
82 TESTING AND ADJUSTING .....	82-1
<b>90 OTHERS</b>	
93 DISASSEMBLY AND ASSEMBLY .....	93-1

The affected pages are indicated by the use of the following marks. It is requested that necessary actions be taken to these pages according to the table below.

Mark	Indication	Action required
○	Page to be newly added	Add
●	Page to be replaced	Replace
( )	Page to be deleted	Discard

Pages having no marks are those previously revised or made additions.

**LIST OF REVISED PAGES**

Mark	Page	Time of revision	Mark	Page	Time of revision	Mark	Page	Time of revision	Mark	Page	Time of revision	Mark	Page	Time of revision
●	00- 1	⑨		00-24			01-15-1	⑦		11-14-1	③		13- 4	①
	00- 2	②		00-25			01-15-2	⑦		11-14-2	③		13- 6	④
●	00- 2-1	⑨		00-26			01-16	②		11-14-3	③		13- 7	④
●	00- 2-2	⑨		00-27			01-17			11-15	②		13- 8	①
●	00- 2-3	⑨		00-28			01-17-1	⑦		11-16	②		13- 9	①
●	00- 2-4	⑨		00-29			01-17-2	⑦		11-17	⑦		13-10	①
●	00- 2-5	⑨		00-30			01-18	⑦					13-12	①
	00- 3			00-31									13-13	①
	00- 4									12- 1	⑦		13-14	①
	00- 5			01- 1			11- 1	②		12- 2	⑦		13-15	①
	00- 6			01- 3			11- 2	⑥		12- 3	⑦		13-16	①
	00- 7			01- 4	⑦		11- 3	⑥		12- 3-1	⑦		13-17	①
	00- 8			01- 5	⑦		11- 4			12- 4	①		13-18	①
	00- 9			01- 6	⑦		11- 5	⑥		12- 5	①		13-19	①
	00-10			01- 7	⑦		11- 6			12- 6	①		13-20	①
	00-11			01- 7-1	⑦		11- 7	②		12- 7	①		13-21	①
	00-12			01- 8	⑦		11- 8	⑦		12- 8	①		13-22	①
	00-13			01- 9	⑦		11- 8-1	⑦		12- 9	①		13-23	①
	00-14			01- 9-1	⑦		11- 9	③		12-10	①		13-24	①
	00-15			01- 9-2	⑦		11-10	②		12-11	⑥		13-25	①
	00-16			01-10	⑦		11-11	②		12-12	①		13-26	①
	00-17			01-11	⑦		11-11-1	⑦	●	12-13	⑨		13-28	④
	00-18			01-11-1	⑦		11-11-2	⑦		12-14	⑧		13-29	①
	00-19			01-11-2	⑦		11-11-3	⑦					13-30	④
	00-20			01-12	⑥		11-11-4	⑤					13-31	④
	00-21			01-13	②		11-12	④		13- .1	④		13-32	①
	00-22			01-14	②		11-13	③		13- 2	①		13-34	④
	00-23			01-15			11-14	②		13- 3	①		13-35	①

LIST OF REVISED PAGES

LIST OF REVISED PAGES

Mark	Page	Time of revision	Mark	Page	Time of revision	Mark	Page	Time of revision	Mark	Page	Time of revision	Mark	Page	Time of revision
	13-36	④		21-34	②		23- 8-8	④		24- 1			34- 9	⑧
	13-37	④		21-35	②		23- 8-9	④		24- 2	②		34-10	⑧
	13-38	①		21-36	②		23- 8-10	④		24- 4	⑥		34-11	⑧
	13-39	①		21-37	⑤		23- 8-11	④		24- 5	②		34-12	⑧
	13-40	④		21-38	⑤		23- 8-12	④		24- 6			34-13	⑧
				21-39	②		23- 9	①		24- 7			34-14	⑧
				21-40	⑥		23-10	①		24- 8			34-15	⑧
	21- 1	②		21-41	⑥		23-11	①		24- 9	②			
	21- 2	②		21-42	⑥		23-12	①		24-10	②			
	21- 3	⑤		21-43	⑥		23-13	①					61- 1	②
	21- 4	②		21-43-1	⑥		23-14	①					61- 2	②
	21- 5	②		21-44	②		23-15	①		31- 1	⑧		61- 3	②
•	21- 6	⑨		21-45	②		23-16	①		31- 2			61- 4	②
	21- 7	②		21-46	⑦		23-17	①		31- 3			61- 5	⑥
	21- 8	⑥		21-47	②		23-18	①		31- 4	⑧		61- 6	⑤
	21- 9	②					23-19	①		31- 5	⑧		61- 7	⑥
	21- 9-1	⑥					23-20	①		31- 5-1	⑧	•	61- 8	⑨
	21- 9-2	⑥		23- 1	④		23-21	①		31- 5-2	⑧		61- 8-1	⑥
	21-10	⑥		23- 2	①		23-22	①		31- 6	⑧		61- 9	⑤
	21-11	②		23- 3	①		23-23	①		31- 7	⑧		61-10	②
	21-12	⑥		23- 4	①		23-24	①		31- 7-1	⑧		61-11	②
	21-13	⑤		23- 5	①		23-25	⑤		31- 7-2	⑧		61-12	②
	21-14	⑤		23- 6	①		23-26	①					61-13	②
	21-15			23- 7	①		23-27	①					61-14	②
	21-16			23- 7-1	④		23-28	①		33- 1	①		61-15	②
	21-18			23- 7-2	④		23-29	①		33- 2	①		61-16	
	21-19	②		23- 7-3	④		23-30	①		33- 3	①		61-17	②
	21-20			23- 7-4	④		23-31	⑥		33- 4	①		61-18	②
	21-21	②		23- 7-5	④		23-32	⑥		33- 5	①		61-19	②
	21-22	⑥		23- 7-6	④		23-33	①		33- 6	①		61-20	②
	21-23			23- 7-7	④		23-34	①		33- 7	①		61-21	②
	21-24	⑥		23- 7-8	④		23-35	⑧					61-22	②
	21-26	②		23- 8	⑤		23-36	⑤					61-23	②
	21-27			23- 8-1	④		23-37	⑧		34- 1	⑧		61-25	⑤
	21-28	②		23- 8-2	④		23-38	⑧		34- 2			61-26	②
	21-29	⑥		23- 8-3	④		23-39	⑧		34- 4	⑧		61-27	②
	21-30	⑥		23- 8-4	④		23-40	⑧		34- 5	②		61-28	⑤
	21-31	②		23- 8-5	④					34- 6	⑧		61-29	②
	21-32	②		23- 8-6	④					34- 7	⑧		61-30	②
	21-33	⑥		23- 8-7	④					34- 8	⑧		61-31	②

LIST OF REVISED PAGES

LIST OF REVISED PAGES

Mark	Page	Time of revision	Mark	Page	Time of revision	Mark	Page	Time of revision	Mark	Page	Time of revision	Mark	Page	Time of revision
	61-32	⑥		61-64	②		62-11	⑤	○	62-51-2	⑨	●	62-85	⑨
	61-33	⑥		61-65	⑧		62-12	⑤	○	62-51-3	⑨		(62-86)	
	61-34	⑧		61-66	⑧		62-13	⑤	○	62-51-4	⑨		(62-88)	
	61-34-1	⑦		61-67	⑦		62-14	⑤	○	62-51-5	⑨		(62-89)	
	61-34-2	⑦		61-68	⑦		62-16	⑤	○	62-51-6	⑨		(62-90)	
	61-35	⑦		61-69	⑤		62-17	⑤		62-52	⑦		(62-91)	
	61-36	⑦	●	61-70	⑨		62-18	⑤	●	62-53	⑨		(62-92)	
	61-37	⑦		61-71	⑤		62-19	⑤		62-54	⑤		(62-93)	
	61-38	⑥		61-72	②		62-20	⑤		62-55	⑤	●	62-94	⑨
	61-39	⑥		61-73	②		62-21	⑤		62-56	⑤	●	62-95	⑨
	61-40	⑦		61-74	⑤		62-22	⑤		62-57	⑤	●	62-96	⑨
	61-41	⑦	●	61-75	⑨		62-23	⑤		62-58	⑤		62-97	⑤
	61-41-1	⑦		61-76	⑤		62-24	⑤		62-59	⑤	●	62-98	⑨
	61-41-2	⑦		61-77	②		62-25	⑤		62-60	⑦		62-99	⑤
	61-42	⑦		61-78	②		62-26	⑤		62-61	⑦		62-100	⑤
	61-43	②		61-79	⑤		62-27	⑤		62-61-1	⑦		62-101	⑤
	61-44	⑦		61-80	⑤		62-28	⑤		62-61-2	⑧	●	62-102	⑨
	61-45	⑤		61-81	②		62-29	⑤		62-62	⑧	●	62-103	⑨
	61-46	⑥		61-82	②		62-30	⑤		62-63	⑤	●	62-104	⑨
	61-47	⑦		61-83	②		62-32	⑤		62-64	⑤	●	62-105	⑨
	61-48	⑦		61-84	⑦		62-33	⑤		62-65	⑤		62-106	⑤
	61-48-1	⑦		61-85	⑦		62-34	⑤		62-66	⑤		62-107	⑤
	61-48-2	⑦		61-86	②		62-35	⑤		62-67	⑧		62-108	⑤
	61-49	⑦		61-87	②		62-36	⑤		62-68	⑤		62-109	⑤
	61-50	②		61-88	②		62-37	⑤		62-69	⑤	●	62-110	⑨
	61-51	⑦		61-89	④		62-38	⑤		62-70	⑤		62-111	⑤
	61-52	⑦		61-90	③		62-39	⑥		62-71	⑧	●	62-112	⑨
	61-53	⑦		61-91	②		62-40	⑤		62-72	⑤	●	62-113	⑨
	61-53-1	⑦					62-41	⑤		62-73	⑤	●	62-114	⑨
	61-53-2	⑦					62-42	⑤		62-74	⑤		62-115	⑤
	61-54	②	●	62- 1	⑨		62-43	⑤		62-75	⑤		62-116	⑤
	61-55	②		62- 2	⑧		62-44	⑤		62-76	⑤		62-117	⑤
	61-56	②		62- 3	⑤		62-45	⑤		62-77	⑤	●	62-118	⑨
	61-57	②		62- 4	⑤		62-46	⑤		62-78	⑦	●	62-120	⑨
●	61-58	⑨		62- 5	⑤	●	62-47	⑨	●	62-79	⑨	●	62-121	⑨
●	61-59	⑨		62- 6	⑤	●	62-48	⑨	●	62-80	⑨		62-122	⑤
	61-60	②		62- 7	⑤	●	62-49	⑨	●	62-81	⑨		62-123	⑤
	61-61	⑤		62- 8	⑤	●	62-50	⑨	●	62-82	⑨	●	62-124	⑨
	61-62	②		62- 9	⑤	●	62-51	⑨	●	62-83	⑨		62-125	⑤
	61-63	②		62-10	⑤	○	62-51-1	⑨		62-84	⑤		62-126	⑦

LIST OF REVISED PAGES

LIST OF REVISED PAGES

Mark	Page	Time of revision	Mark	Page	Time of revision	Mark	Page	Time of revision	Mark	Page	Time of revision	Mark	Page	Time of revision
	62-127	⑤	•	62-152	⑨		63- 9-13	④		64- 1	②		81- 5-5	⑧
	62-128	⑤		(62-153)			63- 9-14	⑤		64- 2	②		81- 6	②
	62-129	⑤	•	62-154	⑨		63- 9-15	⑦	•	64- 3	⑨		81- 7	②
	62-130	⑤	•	62-155	⑨	•	63- 9-16	⑨		64- 4	②		81- 8	②
	62-131-1	⑦	•	62-156	⑨		63- 9-17	⑤		64- 5	⑤		81- 9	③
	62-131-2	⑦	•	62-157	⑨		63- 9-18	⑤		64- 6			81-10	③
	62-131-3	⑦	•	62-158	⑨		63-10	①		64- 7			81-11	③
	62-131-4	⑦	•	62-159	⑨		63-11	①		64- 8			81-12	⑧
	62-131-5	⑦	•	62-160	⑨		63-12	①		64- 9	⑤		81-13	⑧
	62-131-6	⑦	•	62-161	⑨		63-13	①		64-10	③		81-14	⑧
	62-131-7	⑦	•	62-162	⑨		63-14	①		64-11	②		81-15	⑧
	62-131-9	⑦	•	62-163	⑨		63-15	①		64-12	②		81-16	⑧
	62-131-10	⑦		(62-164)			63-16	①		64-13	②		81-17	⑧
	62-131-11	⑦		(62-165)			63-17	①		64-14	②		81-18	⑧
	62-131-12	⑦		(62-166)			63-18	①		64-15	②			
	62-132	⑦		(62-167)			63-19	①		64-16	②			
	62-133	⑦		62-169	⑤		63-20	①		64-17	②		82- 1	⑧
	62-134	⑤		62-170	⑤		63-21	①		64-18	⑥		82- 2	③
	62-135	⑤					63-22	①		64-19	②		82- 3	①
	62-136	⑤					63-23	①		64-20	②		82- 4	③
	62-137	⑤		63- 1	⑤		63-24	①		64-21	②		82- 6	③
	62-138	⑤		63- 2	①		63-25	①		64-22	②		82- 7	③
	62-139	⑤		63- 3	①		63-26	①		64-23	②		82- 8	③
	62-139-1	⑦		63- 4	①		63-27	①		64-24			82- 9	③
	62-139-2	⑦		63- 6	①		63-28	①		64-25	③		82-10	③
	62-139-3	⑦		63- 7	①		63-29	①		64-26			82-11	③
	62-139-4	⑦		63- 8	①		63-30	①		64-28			82-12	③
	62-139-5	⑦		63- 9	①		63-31	①		64-29			82-13	③
	62-139-6	⑦		63- 9-1	⑤		63-32	①		64-30			82-14	⑤
•	62-140	⑨		63- 9-2	⑦		63-34	①					82-15	③
•	62-141	⑨		63- 9-3	⑤		63-35	①					82-16	③
○	62-142	⑨		63- 9-4	⑦		63-36	①		81- 1	⑧		82-17	③
•	62-144	⑨		63- 9-5	⑤		63-37	①		81- 2	②		82-18	③
○	62-145	⑨		63- 9-6	⑤		63-38	①		81- 3	⑧		82-19	③
•	62-146	⑨		63- 9-7	⑤		63-39	①		81- 4	⑧		82-20	③
•	62-147	⑨		63- 9-8	⑤		63-40	①		81- 5	③		82-21	③
•	62-148	⑨		63- 9-9	⑤		63-41	①		81- 5-1	⑦		82-22	⑤
•	62-149	⑨		63- 9-10	⑤		63-42	①		81- 5-2	⑧		82-23	③
•	62-150	⑨		63- 9-11	⑤		63-43	①		81- 5-3	⑧		82-24	③
•	62-151	⑨		63- 9-12	④					81- 5-4	⑧		82-25	③

Mark	Page	Time of revision	Mark	Page	Time of revision	Mark	Page	Time of revision	Mark	Page	Time of revision	Mark	Page	Time of revision
	82-26	③												
	82-27	③												
	82-28	③												
	82-30	③												
	82-31	③												
	82-32	③												
	82-33	③												
	82-35	⑧												
	82-36	⑧												
	82-37	⑧												
	82-38	⑧												
	82-39	⑧												
	82-40	⑧												
	82-41	⑧												
	82-42	⑧												
	82-43	⑧												
	82-44	⑧												
	82-45	⑧												
	82-46	⑧												
	82-47	⑧												
	82-48	⑧												
	82-49	⑧												
	82-50	⑧												
	82-51	⑧												
	82-52	⑧												
	82-53	⑧												
	82-54	⑧												
	82-55	⑧												
	91- 1	①												
	91- 2	①												
	91- 3	①												







---

# 01 GENERAL

---

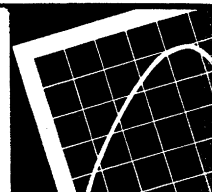

General view .....	01- 3
General assembly drawing .....	01- 4
Specifications .....	01- 8
Engine assembly drawing .....	01-12
List of weight .....	01-14
List of lubricant and water .....	01-18



## GENERAL VIEW

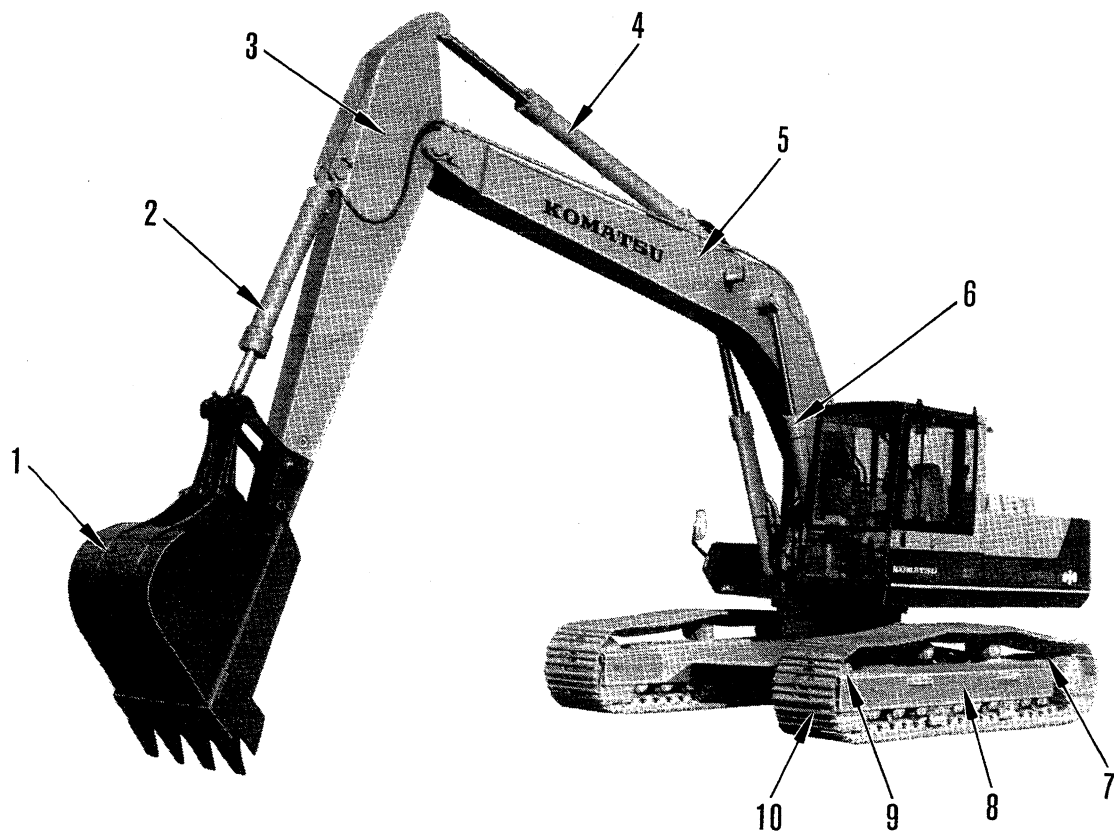

205P2001

1. Bucket
2. Bucket cylinder
3. Arm
4. Arm cylinder
5. Boom
6. Boom cylinder
7. Sprocket
8. Track frame
9. Idler
10. Track shoe

# GENERAL ASSEMBLY DRAWING

PC200-3  
PC210-3

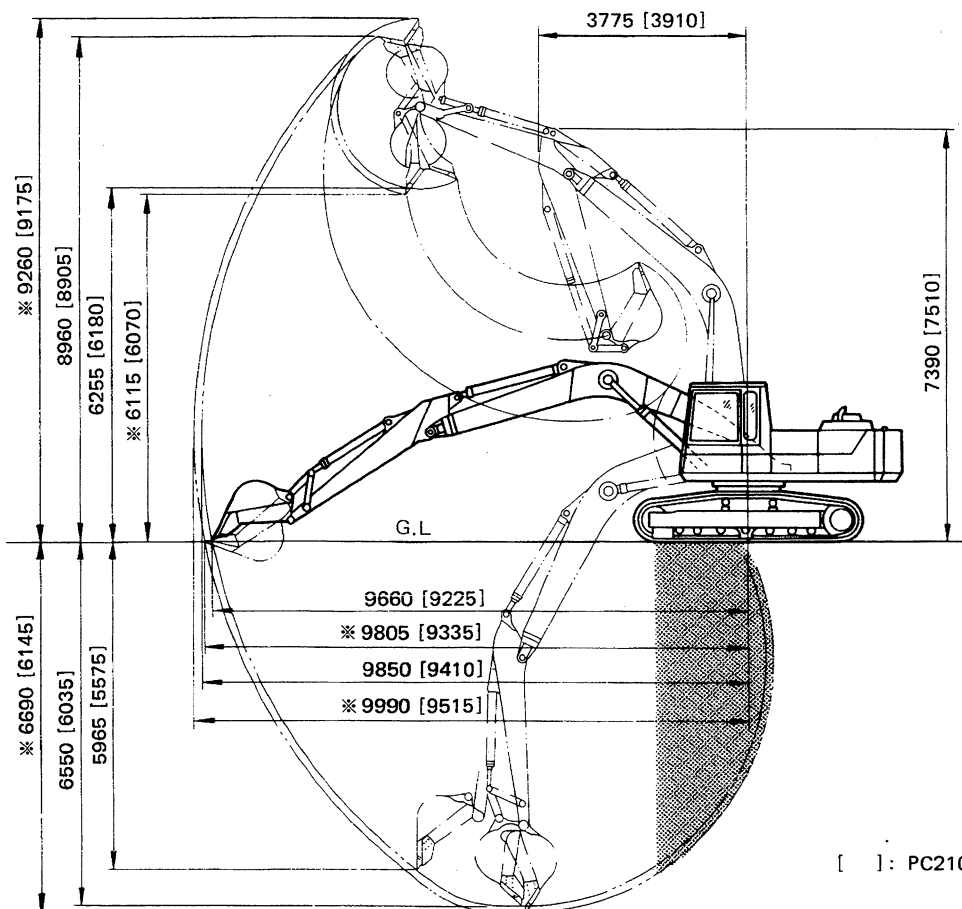
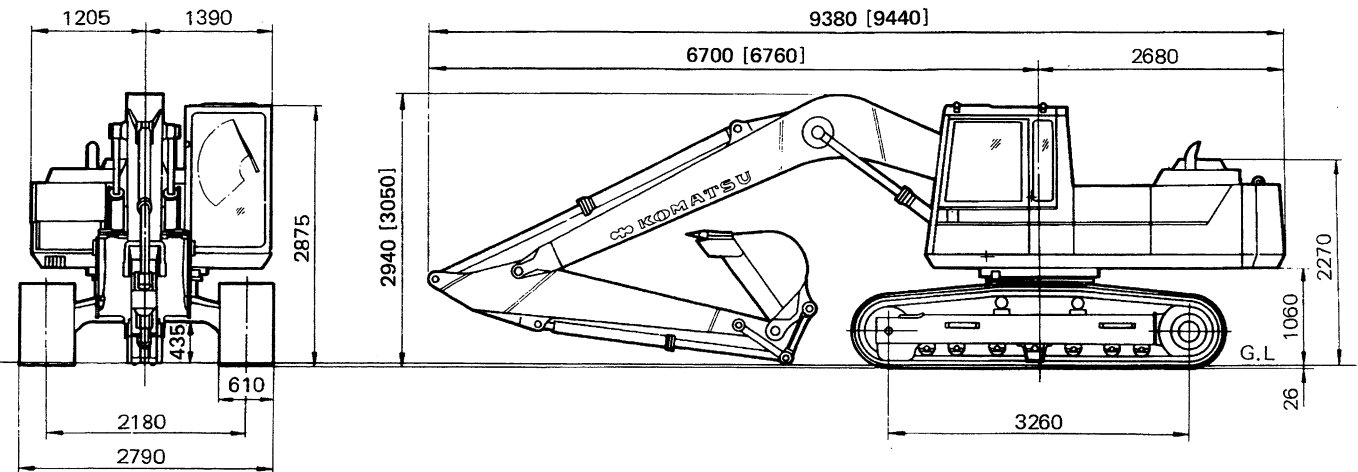
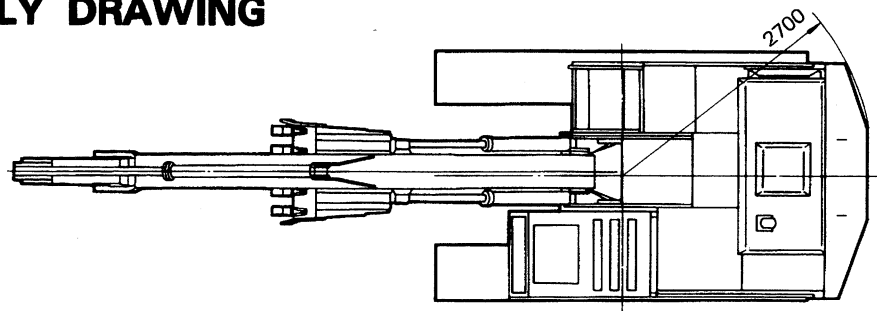

[ ]: PC210-3

The marks \* indicates the dimensions for shovel operation.

205F2001A

PC200LC-3  
PC210LC-3

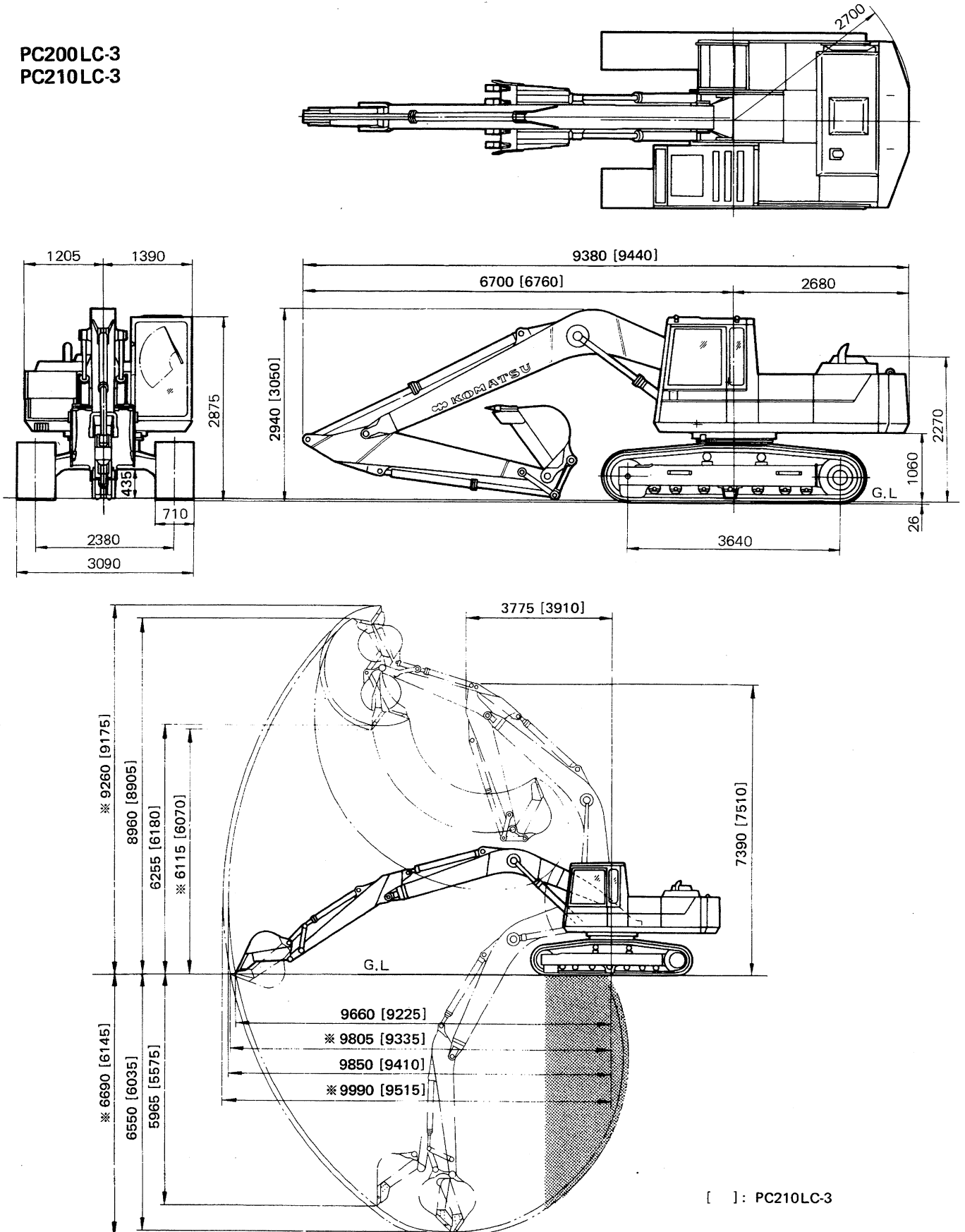

The marks \* indicates the dimensions for shovel operation.

205F2002A

PC220-3  
PC240-3

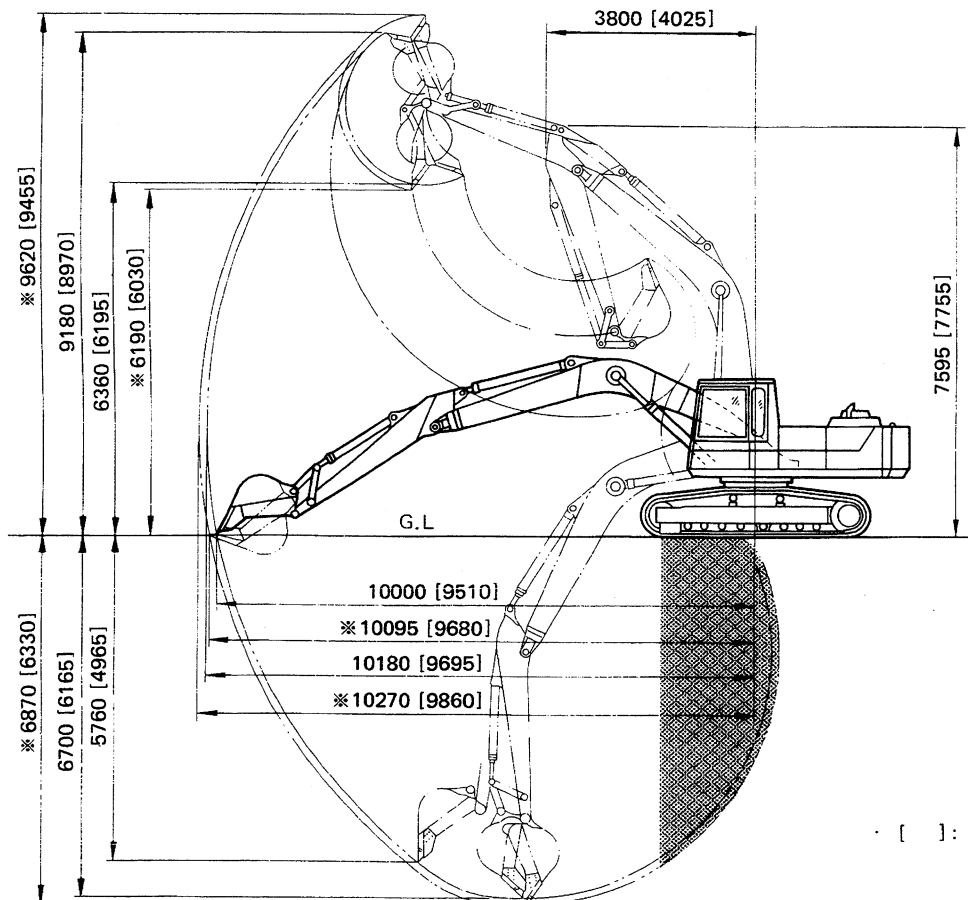
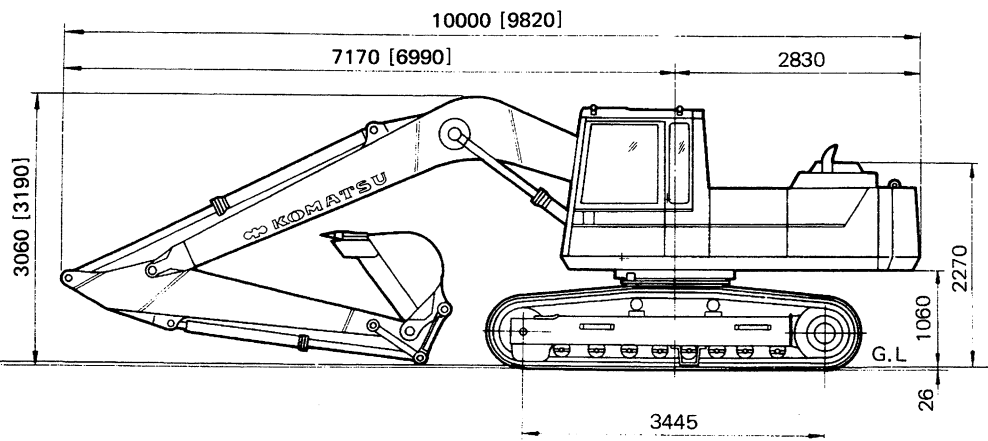
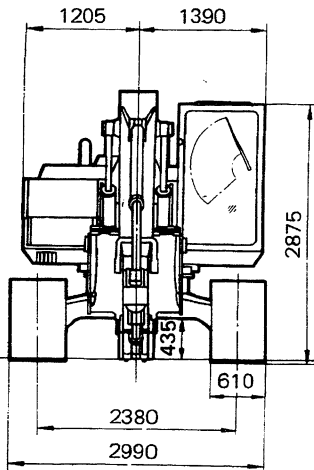
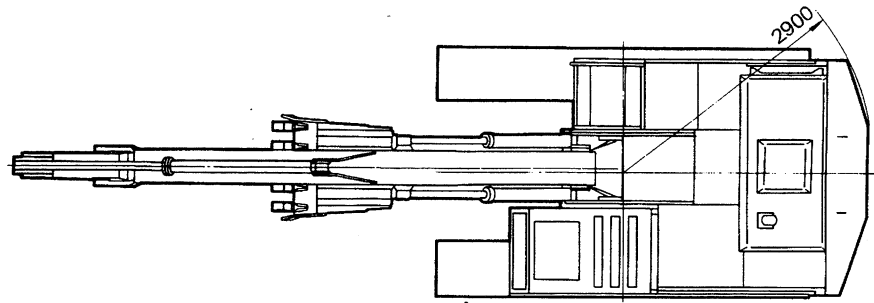

[ ]: PC240-3

The marks ※ indicates the dimensions for shovel operation.  
205F2003A

PC220LC-3  
PC240LC-3

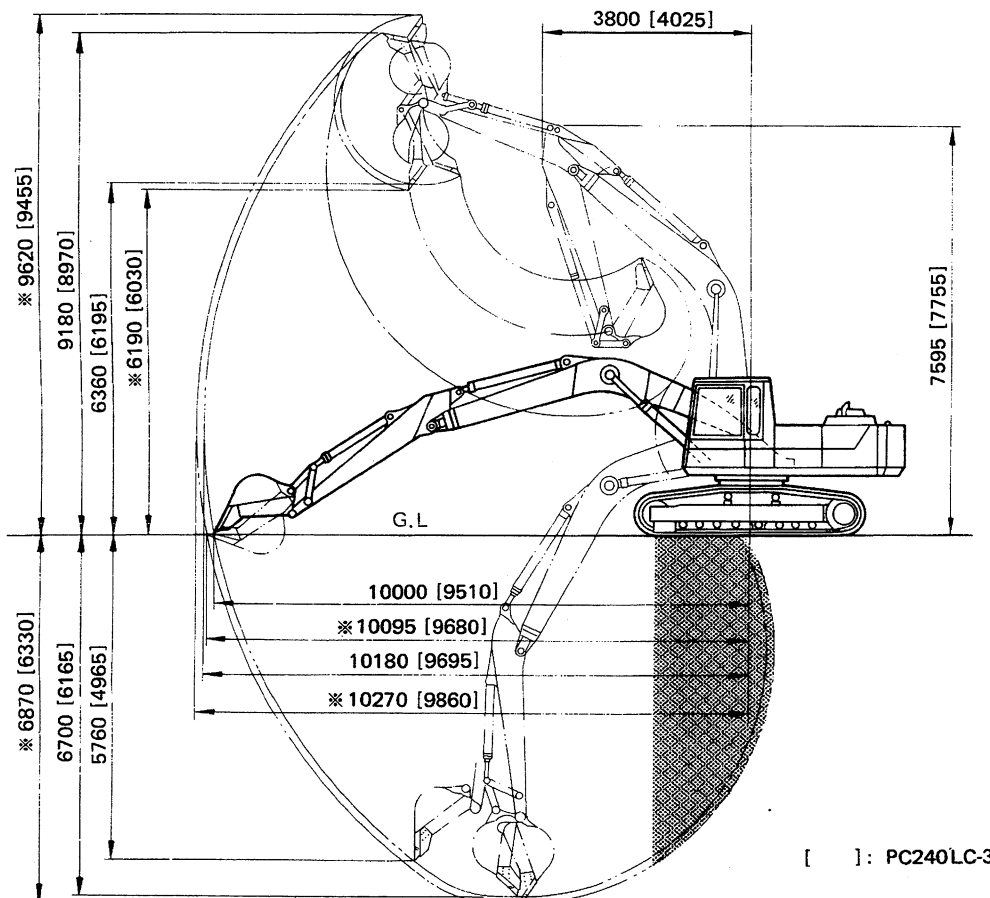
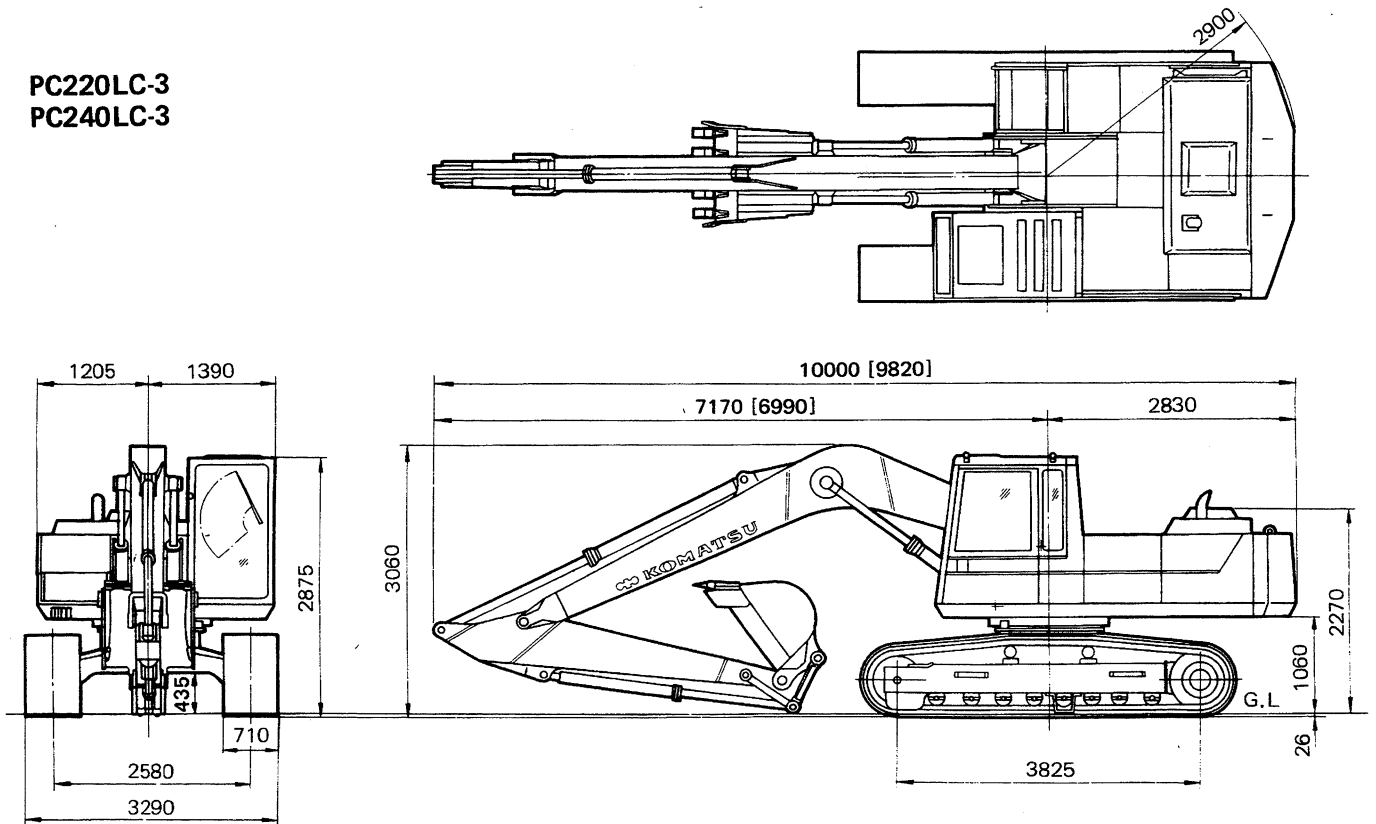

[ ]: PC240LC-3

The marks ※ indicates the dimensions for shovel operation.  
205F2004A



PC240NLC-3

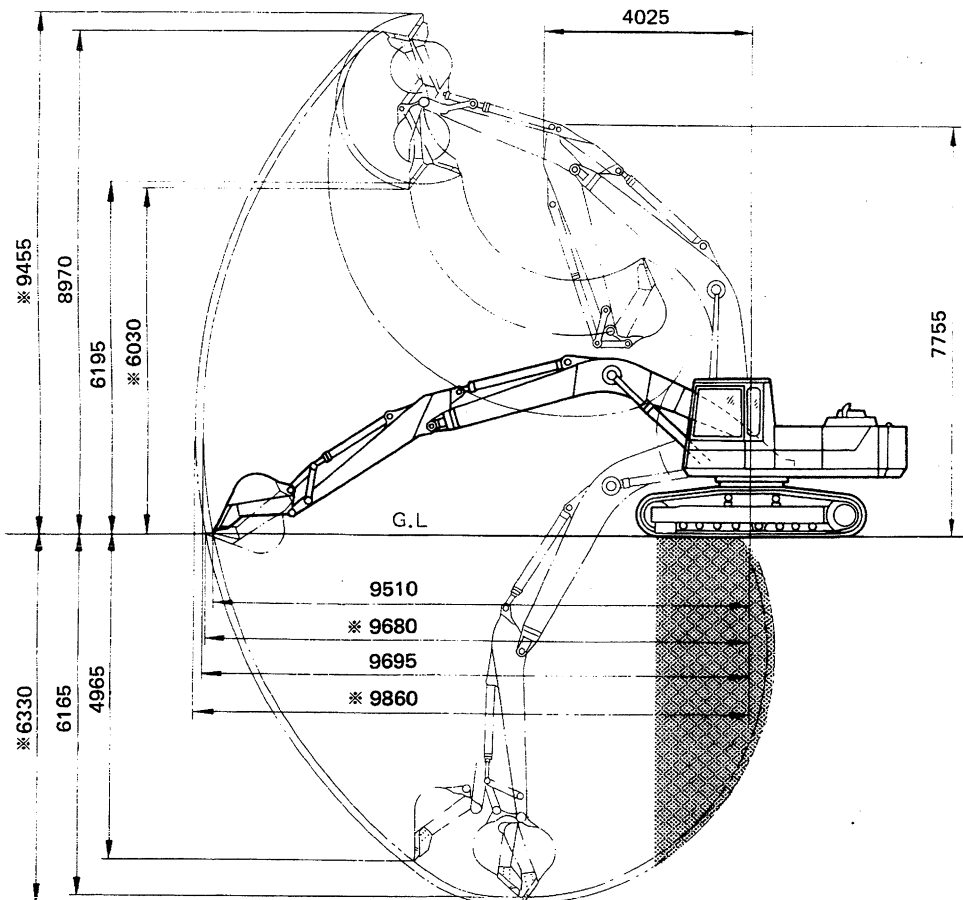
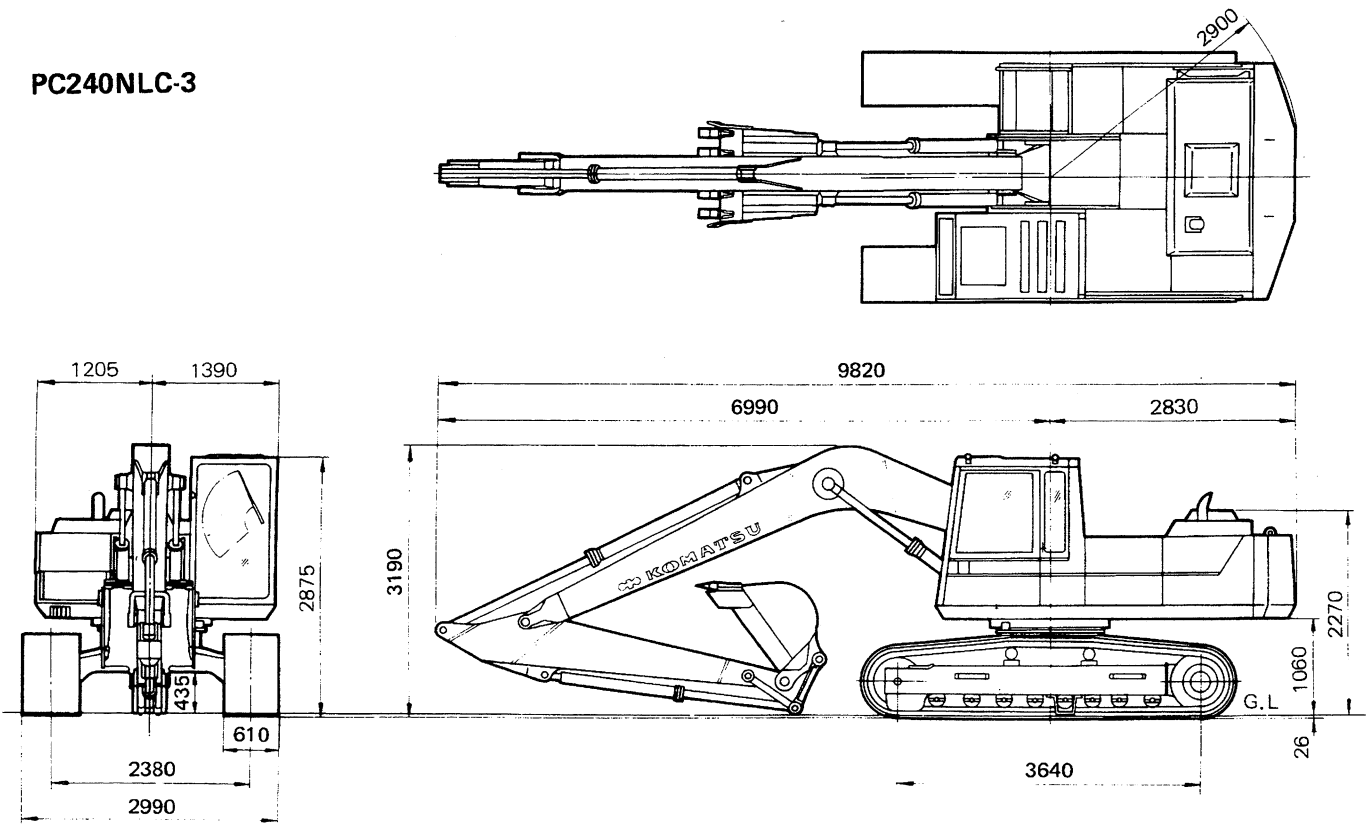

The marks \* indicates the dimensions for shovel operation.  
205F2004B



## SPECIFICATIONS

Machine Model		PC200-3	PC200LC-3	
Serial Numbers		20001 and up	20001 and up	
Operating Weight (kg)		18,000	19,140	
Bucket Capacity (m <sup>3</sup> )		0.7	0.7	
PERFORMANCE	WORKING RANGE	Maximum digging depth (mm)	6,550	6,550
		Vertical wall depth (mm)	5,965	5,965
		Maximum digging reach (mm)	9,850	9,850
		Maximum digging reach at ground level (mm)	9,660	9,660
		Maximum digging height (mm)	8,960	8,960
		Maximum dumping height (mm)	6,255	6,255
	Maximum digging force (kg)	10,700	10,700	
	Continued swing speed (rpm)	13	13	
	Swing maximum slope angle (deg.)	20	20	
	Travel speed (km/h)	3.8	3.4	
	Gradeability (deg.)	35	35	
	Ground pressure (standard triple-shoe) (kg/cm <sup>2</sup> )	0.42 (610 mm)	0.34 (710 mm)	
	DIMENSIONS	Overall length (at transportation) (mm)	9,380	9,380
		Overall width (mm)	2,790	3,090
		Track width (mm)	2,790	3,090
Overall height (at transportation) (mm)		2,940	2,940	
Height of cab (mm)		2,875	2,875	
Ground clearance of counterweight (mm)		1,060	1,060	
Minimum ground clearance (mm)		435	435	
Radius of upper structure (mm)		2,700	2,700	
Minimum swing radius at front end (mm)		3,775	3,775	
Arm height at minimum swing radius (mm)		7,390	7,390	
Length of track on ground (mm)		3,260	3,640	
Track gauge (mm)		2,180	2,380	
Height of machine hood (mm)		2,270	2,270	

## GENERAL

## SPECIFICATIONS

Machine Model		PC200-3		PC200LC-3		
Serial Numbers		20001 – 25846	25847 and up	20001 – 25846	25847 and up	
ENGINE	Engine model	S6D105-B-1				
	Type	4-cycle, in-line vertical, water cooled, direct injection type diesel engine with turbocharger				
	No. of cylinder – bore x stroke	6 – 105 x 125				
	Total displacement	6,494				
	Flywheel horsepower	118/2,100				
	Maximum torque	47/1,600				
	High idling speed	2,300 ± 50				
	Low idling speed	850 ± 50				
	Minimum fuel consumption ratio	155				
	Starting motor	24V, 7.5 kW	24V, 5.5 kW	24V, 7.5 kW	24V, 5.5 kW	
Alternator	24V, 25A					
Battery	24V (12V x 2) – 110 Ah					
Type of radiator core	D-type corrugate fin					
UNDER-CARRIAGE	Carrier roller	(one side)	2	2		
	Track roller	(one side)	7	9		
	Track shoe		Built-up triple grouser		Built-up triple grouser	
HYDRAULIC SYSTEM	HYDRAULIC PUMP	Type, number	Variable displacement piston type x 2 Gear type x 1			
		Delivery	(ℓ/min)	Piston type: 2 x 194 (at rated engine speed) Gear type: 50 (at rated engine speed)		
		Set pressure	(kg/cm <sup>2</sup> )	Piston type: 320 Gear type: 30		
	CONTROL VALVE	Type, number	4-spool type and 5-spool type			
		Control lever operation	Pilot type (Travel control lever: linkage type)			
	HYDRAULIC MOTOR	Travel motor	Piston type (with parking brake) x 2			
		Swing motor	Piston type (with swing mechanical brake (if equipped)) x 1			
	Hydraulic cylinder	Double acting piston				
	Hydraulic tank	Closed box type				
	Hydraulic filter	Tank return side				
Hydraulic cooler	Air cooled					