

# Field Assembly Instruction

HYDRAULIC  
EXCAVATOR

**PC490LC-10**

SERIAL NUMBERS 80001 and up

**KOMATSU**

# FOREWORD

Since this machine is large in size, it is divided into some units to meet the transportation conditions and regulations applied to the transportation route when shipped from our factory.

This manual describes how to assemble the units into the complete machine in the field. We hope that this machine will display its quality and you will use it safely according to the operation manual.

Many units are large in size and heavy in weight and may be handled in a dangerous place or posture and many workers may have to work together to sling them with cranes.

Accordingly, before starting the assembly work, the work supervisor is required to hold a safety meeting to oblige the workers to put on protective gear and appoint a work leader and a crane work signal man and allot roles to all the workers for safe work.

In particular, the above meeting is more important when worker of different languages and customs work together.

The following is a reference supervision system diagram.

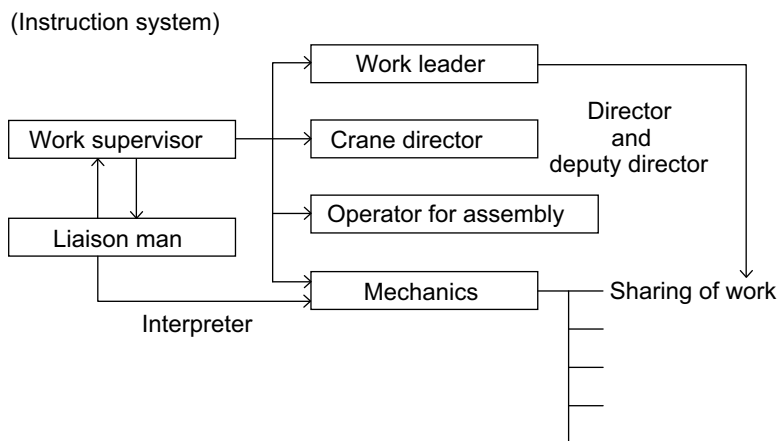

Note that this manual does not describe the whole specification of the machine but describes only the basic specification.

If you have any question when dividing and transporting the machine by yourself in future, ask one of our distributors.



# CONTENTS

Specifications .....	1
Precautions for field assembly .....	2
Disposal of removed parts.....	3
Assembling procedures, applicable equipment and schedule .....	4
Flow of field assembly .....	5
Kit layout diagram.....	6
Transportation .....	7
Tool list for field assembly .....	10
Tightening torque .....	11
Coating materials .....	16
Selection of wire ropes used for assembly.....	20
Selection of nylon slings used for assembly.....	21
A. Assembly of chassis .....	23
A- 1. Installation of climbing step .....	24
A- 2. Installation of handrail .....	25
A- 3. Installation of mirror.....	27
B. Assembling of work equipment .....	31
B- 1. Installation of boom cylinder.....	32
B- 2. Releasing remaining pressure in hydraulic circuit.....	34
B- 3. Installation of boom cylinder hoses .....	35
B- 4. Installation of boom cylinder top pin .....	36
B- 5. Installation of boom assembly .....	37
B- 6. Installation of hoses from chassis along top of boom.....	40
B- 7. Connection of boom cylinder head.....	41
B- 8. Installation of arm assembly.....	42
B- 9. Installation of bucket cylinder hoses between boom and bucket cylinder .....	44
B-10. Installation of bucket.....	46
B-11. Connection of work equipment grease piping .....	49
B-12. Connection of work equipment wiring .....	52
B-13. Greasing after completion of work equipment.....	53
B-14. Bleeding air from work equipment circuit .....	54
C. Increasing and decreasing of track frame gauge, assembling of counterweight.....	55
C- 1. Increasing and decreasing of track frame gauge .....	56
C- 2. Installation of steps .....	62
C- 3. Installation of travel piping covers .....	63
C- 4. Adjustment of track tension .....	67
C- 5. Sticking sheet to counterweight .....	70
C- 6. Installation of camera.....	71
C- 7. Installation of counterweight.....	77
M. Procedure for inspection and maintenance after completion of assembly .....	81
M- 1. Replacement of return filter (Standard filter to flushing filter) .....	82
M- 2. Flushing of hydraulic circuit .....	83
M- 3. Replacement of return filter (Standard filter to flushing filter) .....	85
M- 4. Check of oil/coolant level at each part.....	87
M- 5. Inspection of oil level in hydraulic tank and refill.....	89
M- 6. Parts to be touched up after field assembly.....	91
M- 7. Error code.....	92
Mounting bolt torque check sheet	
Field assembly inspection report (Backhoe)	



# Specifications

Machine model		PC490LC-10
Weight of machine	kg	46,600
Bucket capacity	m <sup>3</sup>	1.9
Engine model	—	KOMATSU SAA6D125E-6
Flywheel horsepower	kW/rpm {HP/rpm}	268/1,900{359/1,900}
Min. ground clearance	mm	700
Travel speed (Low/High)	km/h	3.0/4.2/5.5
Swing speed	rpm	9.1

## PC490LC-10

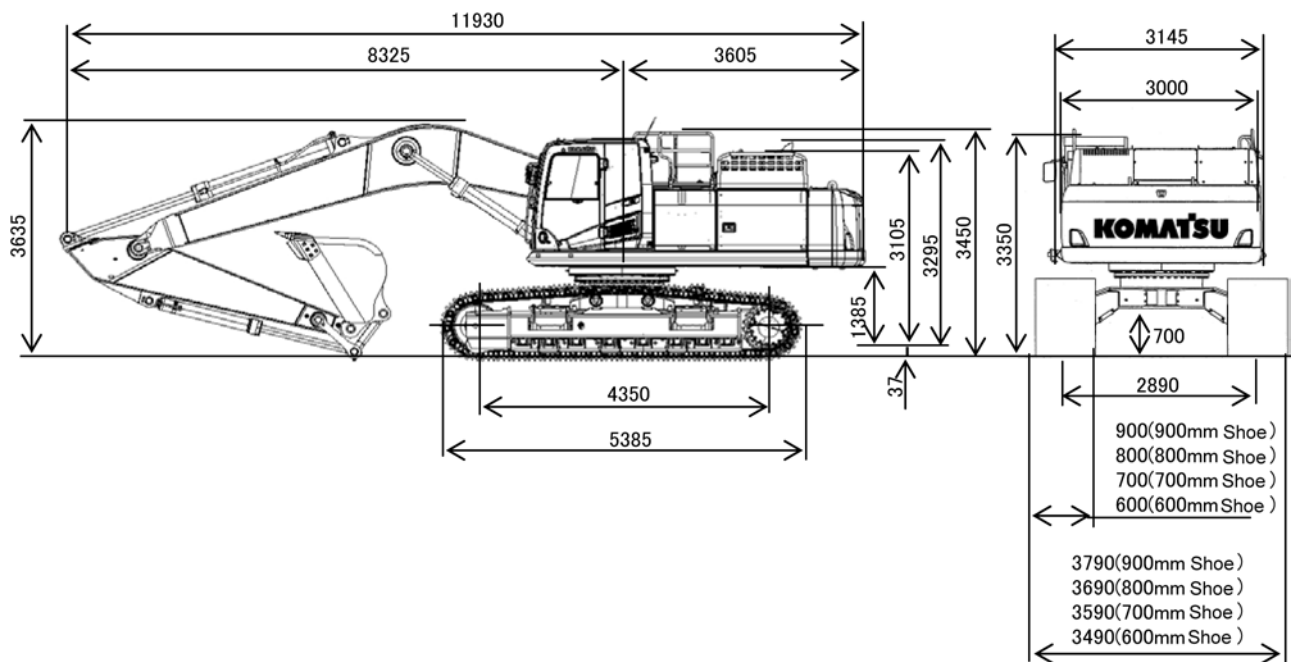

# Precautions for field assembly

## 1. Selection of work place

- 1) When selecting a work place, consider the following.
  - Is the work place sufficiently wide for loading and unloading the machine? (See the kit layout drawing.)
  - Is the ground sufficiently hard? (The machine and crane truck must not sink into the ground.)
  - Is the ground flat? (The ground surface must not be uneven or sloping.)
  - Is the road to inlet/outlet of the work place sufficient for turning the trailer and crane truck?
- 2) Take care extremely that dirt or water will not enter the hydraulic circuit while it is assembled.
- 3) Avoid working outdoors while strong wind is blowing or it is raining.
- 4) Take measures to protect the machine from sand, dirt and rainwater while the work is stopped.

## 2. How to do work

The work supervisor or the work leader should not do the work while reading this manual but should read and understand this manual thoroughly and then start the work.

In particular, write the "Precautions" for each work process in a sheet to explain or stick that sheet to the work place so that all the workers will observe the precautions.

## 3. Preparation and check of protective gear, slings and tools

The work supervisor or the work leader must perform the following checks about protective gear, slings and tools.

- 1) Are all the workers wearing helmets and other protective gear which they are obliged to wear? If special protective gear is necessary, check that it is prepared and can be used without problem.
- 2) Are all the slings and tools prepared? Check in advance that they are ready to be used without problem. In particular, check wooden blocks for internal decay and cracking.

## 4. Check during actual work

The work supervisor or the work leader must check the following items constantly and make all the workers observe them.

- 1) Are the parking brakes of the trailer and crane truck applied securely and are their wheels locked with chocks during work? Are outriggers, if installed, used securely?
  - 2) Are the temperature and pressure of the engine, hydraulic oil, coolant, etc. lowered sufficiently during work?
  - 3) Is horn or another signal is made to warn around when the engine is started? In addition, is it checked that work equipment control lever and other control levers are in neutral and the fuel control dial (or fuel control lever) is in the low idle position?
  - 4) Is the balance of the slung item checked extremely during sling work with the crane?
  - 5) Is entry prohibition for outsiders to the work place observed?
5. The work supervisor or the work leader is required to hold a meeting with all the workers at the beginning of every morning and explain the work plan of the day to them and give them instructions to observe the safe work.

## **Disposal of removed parts**

As described in "FOREWORD", when this machine is transported, it is divided into some units such as the body, undercarriage, cab, work equipment, etc. according to the transportation measure, regulations, etc.

Accordingly, the hydraulic pipings and hydraulic hoses to connect the units, oil inlets and outlets of the hydraulic devices, and parts which must not be damaged are plugged or covered to prevent oil leakage, entry of dirt and dust, and damage during transportation.









In addition, fixing jigs are used to prevent a trouble caused by a fall or a shake during transportation and to facilitate loading, unloading and crane work.

The above plugs, jigs, etc. are removed when the machine is assembled and become unnecessary after completion of the machine. Since they are useful when the machine needs to be transported in future, however, we recommend you to keep them as long as possible.



# Assembling procedures, applicable equipment and schedule

## 3 Division

Days	①				②
Assembly unit ① Unloading parts ② Step ③ Handrail and mirror		 ④ Assembly of work equipment	 ⑤ Increasing of track frame gauge	 ⑥ Installation of counterweight	<ul style="list-style-type: none"> <li>• Inspection of oil level and coolant level</li> <li>• Air bleeding from work equipment cylinder</li> <li>• Flushing of hydraulic circuit</li> <li>• Adjustment of track tension</li> <li>• Performance test</li> </ul>
Crane	 25t				
Air compressor	 5-7kg/cm <sup>2</sup> 15 m <sup>3</sup> /min				
Worker	 Leader + 3 mechanics				
Start of assembling • Meeting with all workers					• Completion of general assembling

## Flow of field assembly

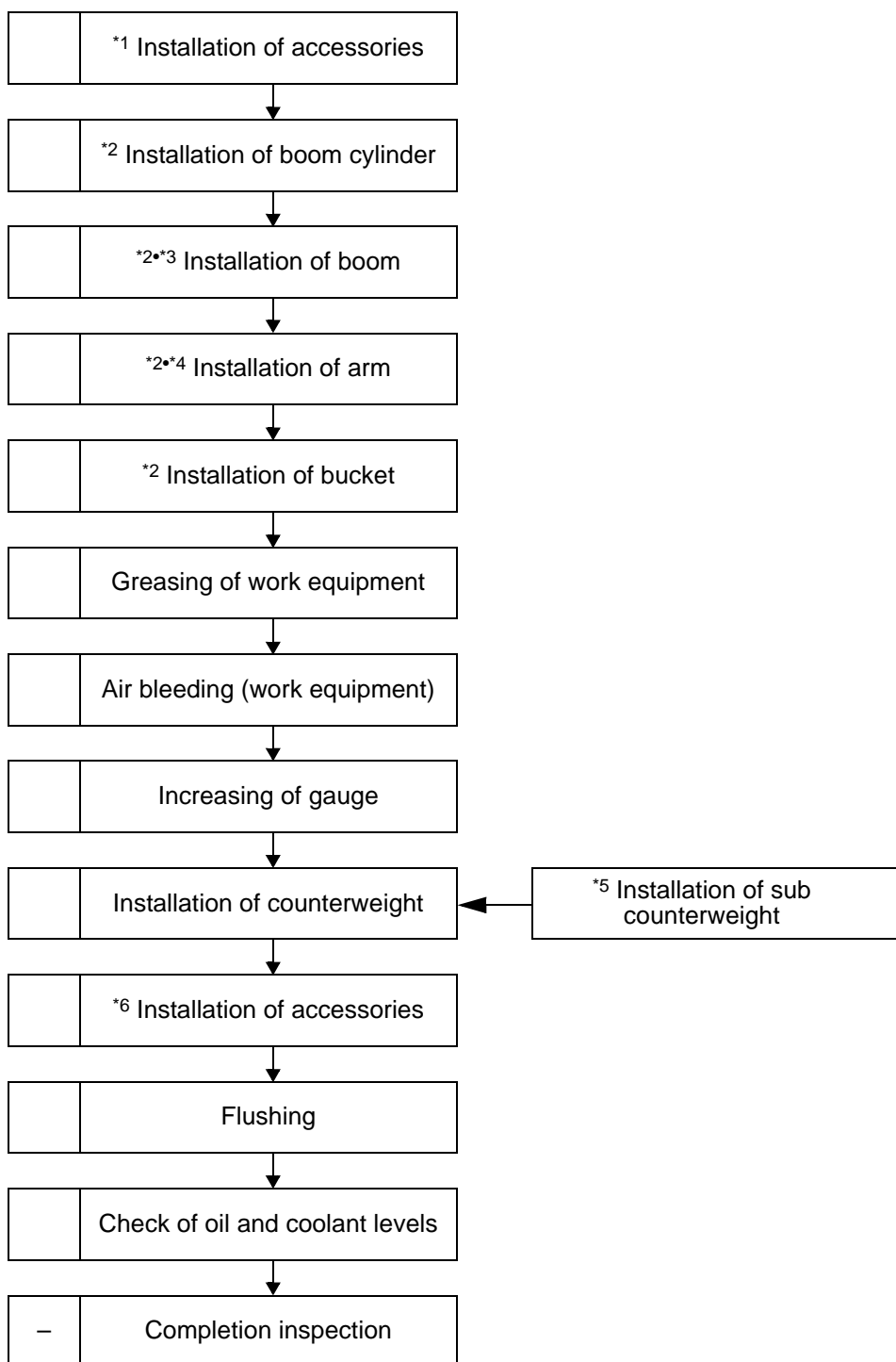

**Precautions**

- \*1: Installation of grip, handrail, and rear view mirror
- \*2: Adjustment of shim
- \*3: Installation of working lamp
- \*4: Bucket cylinder and link are installed before shipment
- \*5: Installation of sound absorbing material, backup lamp, and rear view monitoring camera
- \*6: Installation of track frame step and travel piping cover