

PEB11C1-05

PARTS BOOK

FORKLIFT TRUCK

FG20/25/30-11

FG20S/25S/30S-11

FG30G-11

FG30SG-11

FD25/30-11

FD25S-11

KOMATSU FORKLIFT

PARTS BOOK

FORKLIFT TRUCK

FG20/25/30-11

FG20S/25S/30S-11

FG30G-11

FG30SG-11

FD25/30-11

FD25S-11

SERIAL NUMBERS

FG20/25/30

-450050A and up

FG20S/25S/30S

-400001A and up

FG30G

-490001A and up

FG30SG

-490002A and up

FD25/30

-430175A and up

FD25S

-480001A and up

Date of Issue : FEBRUARY 15, 1993

KOMATSU FORKLIFT CO.,LTD

No. 3-4, Akasaka 2-chome, Minato-ku, Tokyo

KFM 専

INTRODUCTION

This Parts Book includes only parts for the chassis. For engine parts, see the Engine Parts Book. When ordering parts, please inform us also of the Serial No. (truck serial no.) of your truck.

APPLICATION MACHINE

For USA

2.0tons		2.5tons		3.0tons
FG20T-11		FG25T-11		FG30T-11
		FG25T2-11		
		FG25C-11		
FG20ST-11		FG25ST-11		FG30ST-11
		FG25SC-11		
				FG30GT-11
				FG30GT2-11
				FG30SGT-11
		FD25T-11		FD30T-11
		FD25ST-11		

Machine code

--	--

F D



G : Gasoline
D : Diesel

Capacity code

--	--	--	--

2 5

NO code: Outdoor
S : Indoor

Type code

--	--

G

V : Swirl type
G : G type

Power train code

--	--

T

C : Clutch type
T : Torqflow F1/R1 type
T2 : Torqflow F2/R2 type

SERIAL NUMBER

FG20/25/30	- 450050A and up (H20 NISSAN engine)
FG20S/25S/30S	- 400001A and up (H20 NISSAN engine)
FG30G	- 490001A and up (G1600 HERCULES engine)
FG30SG	- 490002A and up (G1600 HERCULES engine)
FD25/30	- 430175A and up (4D95S.W KOMATSU engine)
FD25S	- 480001A and up (4D95S.W KOMATSU engine)

The parts book is written using the following methods which should be thoroughly understood.

ILLUSTRATION

FIG.3701A BRAKE SYSTEM

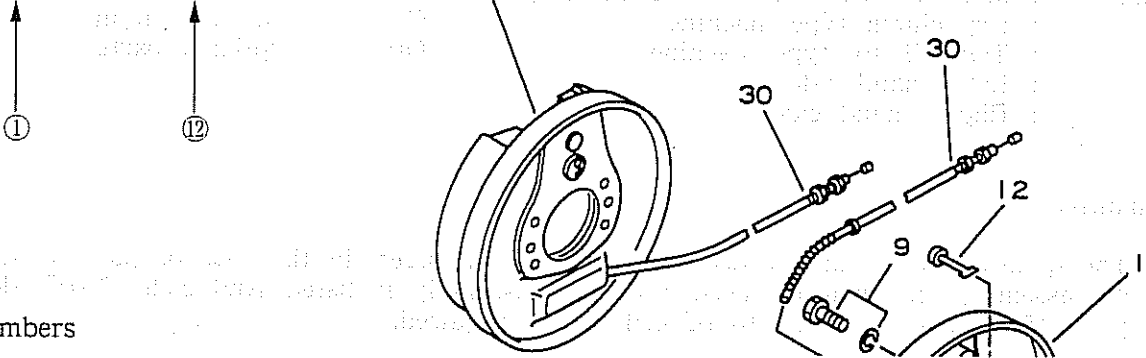

① Fig Numbers

PARTS LIST

①	②	③	④	⑤	⑥	⑦	⑧	⑨	⑩	⑪	⑫	
国 指 Fig Index	品 目 番 号 No	品 番 Part No.	品 名 Description	個 数 Qty	BRAKE SYSTEM							
					適用機種 Application							
		3EB-30-23103	BRAKE ASS'Y (L.H)...	1	FG20	T	-C	450050A~				
		3EB-30-23203	BRAKE ASS'Y (R.H)...	1	FG25	C	-C	450050A~				
		3EB-30-11110	BACKING PLATE ASS'Y (L.H)	1	FG25	T	-C	450050A~				
3701A-1					FG20S	T	-C	400001A~				
					FG25S	C	-C	400001A~				

② Index Numbers

③ Part Numbers

☆...These parts are not available as individual parts. They are only supplied as part of an assembly.

④ Code for components of assembly

Parts constituting an assembly have a (.) mark before the part name, and are listed below the name of the assembly. When the part constitutes a sub-assembly a (..) mark precedes the part name.

⑤ Description

⑥ Abbreviations

Abbreviations are given in brackets after the part name to indicate the category of special part.

H20	: Machines with H20 gasoline engine	3.0m	: Lifting height 3.0m
G1600	: Machines with G1600 gasoline engine	2.0T	: 2.0ton trucks
4D95S.W	: Machines with 4D95S.W diesel engine	D	: Diesel engine
C	: Dry clutch type machine	G	: Gasoline engine
T	: TORQFLOW type machine	OP	: Optional parts
L.H	: Left - hand side		
R.H	: Right - hand side		

⑦ Quantity

The quantity of a part needed for one truck is listed. In the case of parts constituting an assembly, the quantity needed for one assembly is listed. And code "AR" denote the part (for instance shim) to be ordered as required.

APPLICATION

This indicates the model, specification and serial numbers of trucks to which the information on the page applies.

⑧ Model

NO code : Outdoor type S : Indoor G : G Type

⑨ Power train

T.....TORQFLOW DRIVE (including T2:F2, but there is a separate page for T2 machines.)
C.....DIRECT DRIVE

⑩ Country code

C.....For USA

⑪ Applicable models

This indicates the serial numbers of trucks on which the parts on the page are used.
450050A ~ ... Applies to all models from No.450050A
(or the serial number given)

⑫ Title

This indicates the name of the unit or the name of the main part.
The abbreviation given in brackets after the title indicates the category of the unit.

FHPS : Full Hydraulic Power Steering

CONTENTS

1.ENGINE RELATED PARTS AND ELECTRICAL SYSTEM	FIG.NO.
ENGINE MOUNTING PARTS (FOR 4D95S.W).....	1001A
ENGINE MOUNTING PARTS (FOR H20).....	1051
ENGINE MOUNTING PARTS (FOR G1600).....	1071A
AIR CLEANER (FOR 4D95S.W).....	1101A
AIR CLEANER (FOR H20).....	1111
AIR CLEANER (FOR G1600).....	1151
EXHAUST SYSTEM (FOR 4D95S.W).....	1201A
EXHAUST SYSTEM (FOR H20).....	1251A
EXHAUST SYSTEM (FOR G1600).....	1271A
RADIATOR (FOR 4D95S.W).....	1301A
RADIATOR (FOR H20).....	1351
RADIATOR (FOR G1600).....	1361
RADIATOR (FOR G1600,S).....	1371
RADIATOR COVER.....	1391A
RADIATOR COVER (FOR G1600).....	1392
RADIATOR COVER (FOR S).....	1393A
RADIATOR COVER (FOR G1600,S).....	1395
FUEL SYSTEM (FOR 4D95S.W).....	1403A
FUEL SYSTEM (FOR H20).....	1453
FUEL SYSTEM (FOR G1600).....	1473
ELECTRICAL SYSTEM (FOR 4D95S.W).....	1501A
ELECTRICAL SYSTEM (FOR 4D95S.W).....	1502A
ELECTRICAL SYSTEM (FOR 4D95S.W).....	1503A
ELECTRICAL SYSTEM (FOR H20,G1600).....	1601B

C O N T E N T S

G T M 3 7 1 0 0

FIG.NO.

1. ELECTRICAL SYSTEM (FOR H20,G1600)1602

2. ELECTRICAL SYSTEM (FOR H20)1603A

3. ELECTRICAL SYSTEM (FOR G1600)1605

2. CLUTCH, TORQUE CONVERTER AND TRANSMISSION

1. DRY CLUTCH.....2001A

2. CLUTCH RELEASE CYLINDER.....2041A

3. TORQUE CONVERTER.....2101A

4. TORQUE CONVERTER (FOR G1600,T2-TYPE)2121

5. DIRECT DRIVE TRANSMISSION (1/3)2201A

6. DIRECT DRIVE TRANSMISSION (2/3)2202

7. DIRECT DRIVE TRANSMISSION (3/3)2203

8. TORQFLOW DRIVE TRANSMISSION (1/2)2301A

9. TORQFLOW DRIVE TRANSMISSION (2/2)2302

10. TORQFLOW DRIVE TRANSMISSION VALVE.....2303

11. TORQFLOW DRIVE TRANSMISSION (FOR T2-TYPE) (1/3)2401

12. TORQFLOW DRIVE TRANSMISSION (FOR T2-TYPE) (2/3)2402A

13. TORQFLOW DRIVE TRANSMISSION (FOR T2-TYPE) (3/3)2403

14. TORQFLOW DRIVE TRANSMISSION VALVE (FOR T2-TYPE)2404

15. TRANSMISSION PIPING.....2501

3. DIFFERENTIAL, AXLE AND WHEELS

1. DIFFERENTIAL GEAR.....3101A

2. DRIVE AXLE.....3201A

3. DRIVE AXLE (FOR S)3211A

4. STEERING AXLE (FOR S) (1/2)3311

	FIG.NO.
STEERING AXLE (FOR S) (2/2)	3312
STEERING AXLE (FOR FHPS)	3351
STEERING AXLE (FOR FHPS,S)	3352
FRONT WHEEL	3401
FRONT WHEEL (FOR S)	3405
REAR WHEEL	3601
REAR WHEEL (FOR S)	3605
BRAKE SYSTEM	3701A
4. STEERING AND CONTROL SYSTEM	
STEERING WHEEL	4001
STEERING COLUMN	4101
STEERING COLUMN (FOR FHPS)	4131
STEERING GEAR BOX	4151A
STEERING LINKAGE	4201
POWER STEERING VALVE (FOR FHPS)	4251A
TRANSMISSION SHIFT LEVER (FOR CLUTCH)	4301
TRANSMISSION SHIFT LEVER (FOR T1) (L.H)	4351
TRANSMISSION SHIFT LEVER (FOR FHPS,T1) (L.H)	4355A
TRANSMISSION SHIFT LEVER (FOR T2) (L.H)	4361
TRANSMISSION SHIFT LEVER (FOR FHPS,T2) (L.H)	4365
BRAKE AND CLUTCH PEDAL (DIRECT DRIVE)	4401A
BRAKE AND INCHING PEDAL (TORQUFLOW DRIVE)	4451
MASTER CYLINDER (FOR CLUTCH)	4501A
MASTER CYLINDER (FOR BRAKE)	4521

C O N T E N T S

	FIG.NO.
ACCELERATOR PEDAL (FOR 4D95S.W)	4601A
ACCELERATOR PEDAL (FOR H20)	4651
ACCELERATOR PEDAL (FOR G1600)	4671
BRAKE PIPING.....	4701A
PARKING BRAKE LEVER.....	4801
5.FRAME AND BODY	
FRAME.....	5001A
FRAME (FOR S)	5011A
OUTER PANEL.....	5101A
OUTER PANEL.....	5121A
OUTER PANEL (FOR INSULATOR)	5201A
OUTER PANEL (FOR INSULATOR,S)	5203A
OUTER PANEL (ENCLOSE) (FOR 4D95S.W)	5301
OPERATOR'S SEAT.....	5401
HEAD GUARD.....	5501A
HEAD GUARD (FOR S)	5503A
NAME PLATE (FOR D)	5701A
NAME PLATE (FOR G)	5751A
6.WORK EQUIPMENT AND IT'S CONTROL SYSTEM	
HYDRAULIC PUMP (FOR 4D95S.W)	6001A
HYDRAULIC PUMP (FOR H20)	6031
HYDRAULIC PUMP (FOR G1600)	6041
CONTROL VALVE.....	6101A
2-SPOOL CONTROL VALVE LEVER.....	6201

	FIG.NO.
3-SPPOOL CONTROL VALVE LEVER.....	6251A
TILT CYLINDER (6°/10°,6°/12°)	6331
POWER STEERING CYLINDER.....	6361
POWER STEERING CYLINDER (FOR FHPS)	6365A
POWER STEERING PIPING (FOR FHPS)	6370A
HYDRAULIC PIPING (FOR 4D95S.W) (1/3)	6401A
HYDRAULIC PIPING (FOR 4D95S.W) (2/3)	6402A
HYDRAULIC PIPING (FOR 4D95S.W) (3/3)	6403A
HYDRAULIC PIPING (FOR H20,G1600) (1/4)	6501
HYDRAULIC PIPING (FOR H20,G1600) (2/4)	6502A
HYDRAULIC PIPING (FOR H20) (3/4)	6503
HYDRAULIC PIPING (FOR G1600) (3/4)	6504
HYDRAULIC PIPING (FOR H20,G1600) (4/4)	6505
K.KIT	
KIT.....	K
N.NUMERICAL INDEX	
NUMERICAL INDEX.....	N
7.CASCADE MAST (2-STAGE) (FOR C-SPEC)	
SAFTY DECALS AND PUBLICATIONS.....	7001
MAIN LIFT CYLINDER-2600PSI.....	7002
MAIN LIFT CYLINDER-2600PSI.....	7003
INTERNAL HOSE REEVING.....	7004
INTERNAL HOSE REEVING.....	7005
OUTER UPRIGHT.....	7006
FG(D) 20,25,30	