

SHOP MANUAL



3D82AE SERIES

3D84E SERIES

3D88E SERIES

4D88E SERIES

4D98E SERIES

4D106 SERIES

S4D84E SERIES

S4D98E SERIES

S4D106 SERIES

DIESEL ENGINE



SHOP MANUAL



APPLICABLE MACHINE MODEL	ENGINE MODEL	
	YANMAR DESCRIPTION	KOMATSU DESCRIPTION
PC27R-8	3TNV82A-M5FA	3D82AE-5MFA
PC35R-8	3TNV88-N5FA	3D88E-5NFA
PC45R-8	4TNV88-N5FA	4D88E-5NFA
PC75R-2	4TNV98-X2FB	4D98E-2XFB
PW75R-2	4TNV98-X2FB	4D98E-2XFB
PC95R-2	4TNV106-S2FB	4D106-2SFB
PW95R-2	4TNV106-S2FB	4D1062SFB
PC110R-1	4TNV106T-W2FB	S4D106-2WFB
PW110R-1	4TNV106T-W2FB	S4D106-2WFB
SK510-5	3TNV84-K5FD	3D84E-5KFD
SK714-5	4TNV88-K5FD	4D88E-5KFD
SK815-5	4TNV88-K5FD	4D88E-5KFD
SK815-5 turbo	4TNV84T-K5FD	S4D84E-5KFD
SK818-5	4TNV88-K5FD	4D88E-5KFD
SK820-5 turbo	4TNV84T-K5FD	S4D84E-5KFD
SK1020-5	4TNV98-N2FE	4D98E-2NFE
SK1020-5 turbo	4TNV98T-N2FE	S4D98E-2NFE
SK1026-5 turbo	4TNV98T-N2FE	S4D98E-2NFE
WB70A-1	4TNV98-N2FA	4D98E-2NFA
WB98A-2	4TNV106T-S2FC	S4D106-2SFC
WB91R-2	4TNV106-S2FA	4D106-2SFA
WB93R-2	4TNV106T-S2FA	S4D106-2SFA
WB97R-2	4TNV106T-S2FA	S4D106-2SFA
WB97S-2	4TNV106T-S2FA	S4D106-2SFA
WB150AWS-2	4TNV106T-S2FA	S4D106-2SFA

PREFACE

This manual describes the service procedures for the TNV series engines of indirect injection system that have been certified by the US EPA, California ARB and/or the 97/68/EC Directive for industrial use.

Please use this manual for accurate, quick and safe servicing of the said engine. Since the explanation in this manual assumes the standard type engine, the specifications and components may partially be different from the engine installed on individual work equipment (power generator, pump, compressor, etc.). Please also refer to the service manual for each work equipment for details.

The specifications and components may be subject to change for improvement of the engine quality without notice. If any modification of the contents described herein becomes necessary, it will be notified in the form of correction information each time.

SAFETY LABELS

- Most accidents are caused by negligence of basic safety rules and precautions. For accident prevention, it is important to avoid such causes before development to accidents. Please read this manual carefully before starting repair or maintenance to fully understand safety precautions and appropriate inspection and maintenance procedures.
Attempting at a repair or maintenance job without sufficient knowledge may cause an unexpected accident.
- It is impossible to cover every possible danger in repair or maintenance in the manual. Sufficient consideration for safety is required in addition to the matters marked . Especially for safety precautions in a repair or maintenance job not described in this manual, receive instructions from a knowledgeable leader.
- Safety marks used in this manual and their meanings are as follows:



DANGER-indicates an imminently hazardous situation, which, if not avoided, WILL result in death or serious injury.



WARNING-indicates a potentially hazardous situation, which, if not avoided, COULD result in death or serious injury.



CAUTION-indicates a potentially hazardous situation, which, if not avoided, MAY result in minor or moderate injury.

- **NOTICE**-indicates that if not observed, the product performance or quality may not be guaranteed.

Safety Precautions

(1) SERVICE AREA



● Sufficient Ventilation

Inhalation of exhaust fumes and dust particles may be hazardous to one's health. Running engines, welding, sanding, painting, and polishing tasks should be only done in well ventilated areas.



● Safe / Adequate Work Area

The service area should be clean, spacious, level and free from holes in the floor, to prevent "slip" or "trip and fall" type accidents.



● Bright, Safely Illuminated Area

The work area should be well lit or illuminated in a safe manner. For work in enclosed or dark areas, a "drop cord" should be utilized. The drop cord must have a wire cage to prevent bulb breakage and possible ignition of flammable substances.



● Safety Equipment

Fire extinguisher(s), first aid kit and eye wash / shower station should be close at hand (or easily accessible) in case of an emergency.

(2) WORK – WEAR (GARMENTS)

CAUTION



● Safe Work Clothing

Appropriate safety wear (gloves, special shoes/boots, eye/ear protection, head gear, harness', clothing, etc.) should be used/worn to match the task at hand. Avoid wearing jewelry, unbuttoned cuffs, ties or loose fitting clothes around moving machinery. A serious accident may occur if caught in moving/rotating machinery.

(3) TOOLS

WARNING

● Appropriate Lifting / Holding

When lifting an engine, use only a lifting device (crane, jack, etc.) with sufficient lifting capacity. Do not overload the device. Use only a chain, cable, or lifting strap as an attaching device. Do not use rope, serious injury may result.

To hold or support an engine, secure the engine to a support stand, test bed or test cart designed to carry the weight of the engine. Do not overload this device, serious injury may result.

Never run an engine without being properly secured to an engine support stand, test bed or test cart, serious injury may result.

CAUTION

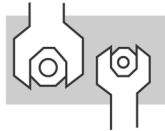

● Appropriate Tools

Always use tools that are designed for the task at hand. Incorrect usage of tools may result in damage to the engine and or serious personal injury.

(4) GENUINE PARTS and MATERIALS

CAUTION



● Genuine Parts

Always use genuine parts or recommended parts and goods. Damage to the engine, shortened engine life and or personal injury may result.

(5) FASTENER TORQUE

WARNING

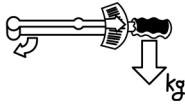

● Torqueing Fasteners

Always follow the torque values and procedures as designated in the service manual. Incorrect values, procedures and or tools may cause damage to the engine and or personal injury.

(6) Electrical

WARNING

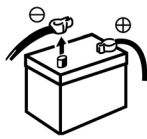

● Short Circuits

Always disconnect the (-) Negative battery cable before working on the electrical system. An accidental "short circuit" may cause damage, fire and or personal injury. Remember to connect the (-) Negative battery cable (back onto the battery) last. Fasten the terminals tightly.

WARNING



● Charging Batteries

Charging wet celled batteries produces hydrogen gas. Hydrogen gas is extremely explosive. Keep sparks, open flame and any other form of ignition away. Explosion may occur causing severe personal injury.

WARNING



● Battery Electrolyte

Batteries contain sulfuric acid. Do NOT allow it to come in contact with clothing, skin and or eyes, severe burns will result.

(7) WASTE MANAGEMENT

CAUTION

Observe the following instructions with regard to hazardous waste disposal. Negligence of these will have a serious impact on environmental pollution concerns.

- 1) Waste fluids such as lube oil, fuel and coolant shall be carefully put into separate sealed containers and disposed of properly.
- 2) Do NOT dispose of waste materials irresponsibly by dumping them into the sewer, overland or into natural waterways.
- 3) Waste materials such as oil, fuel, coolant, solvents, filter elements and batteries, must be disposed of properly according to local ordinances. Consult the local authorities or reclamation facility.

(8) FURTHER PRECAUTIONS

WARNING



● Fueling / Refueling

Keep sparks, open flames or any other form of ignition (match, cigarette, etc.) away when fueling/refueling the unit. *Fire and or an explosion may result.*

WARNING



● Hot Surfaces.

Do NOT touch the engine (or any of its components) during running or shortly after shutting it down. *Scalding / serious burns may result.* Allow the engine to cool down before attempting to approach the unit.

WARNING



● Rotating Parts

Be careful around moving/rotating parts. Loose clothing, jewelry, ties or tools may become entangled causing damage to the engine and or severe personal injury.

WARNING



● Preventing burns from scalding

- 1) Never open the radiator filler cap shortly after shutting the engine down.
Steam and hot water will spurt out and seriously burn you. Allow the engine to cool down before attempt to open the filler cap.
- 2) Securely tighten the filler cap after checking the radiator.
Steam can spurt out during engine running, if tightening loose.

Precautions for Service Work

(1) Precautions for Safety

Read the safety precautions given at the beginning of this manual carefully and always mind safety in work.

(2) Preparation for Service Work

Preparation is necessary for accurate, efficient service work. Check the customer ledger file for the history of the engine.

- Preceding service date
- Period/operation hours after preceding service
- Problems and actions in preceding service
- Replacement parts expected to be required for service
- Recording form/check sheet required for service

(3) Preparation before Disassembly

- Prepare general tools, special service tools, measuring instruments, oil, grease, non-reusable parts, and parts expected to be required for replacement.
- When disassembling complicated portions, put match-marks and other marks at places not adversely affecting the function for easy reassembly.

(4) Precautions in Disassembly

- Each time a parts is removed, check the part installed state, deformation, damage, roughening, surface defect, etc.
- Arrange the removed parts orderly with clear distinction between those to be replaced and those to be used again.
- Parts to be used again shall be washed and cleaned sufficiently.
- Select especially clean locations and use clean tools for disassembly of hydraulic units such as the fuel injection pump.

(5) Precautions for Inspection and Measurement

Inspect and measure parts to be used again as required to determine whether they are reusable or not.

(6) Precautions for Reassembly

- Reassemble correct parts in correct order according to the specified standards (tightening torques, and adjustment standards). Apply oil important bolts and nuts before tightening when specified.
- Always use genuine parts for replacement.
- Always use new oil seals, O-rings, packing and cotter pins.
- Apply sealant to packing depending on the place where they are used. Apply of grease to sliding contact portions, and apply grease to oil seal lips.

(7) Precautions for Adjustment and Check

Use measuring instruments for adjustment to the specified service standards.

How to Read this Manual

(1) Range of Operation Explanation

This manual explains the troubleshooting, installation/removal, replacement, disassemble/reassembly, inspection, adjustment and adjusting operation procedures for the TNV series engines with direct injection system.

Refer to the manufacturer's manual for each of the fuel injection pump, governor, starting motor and alternator except for their installation.

(2) How to Read the Explanations

- An exploded view, sectional views, a system diagram, etc. are shown at the beginning of each section as required for easy understanding of the mounted states of the components.
- For the removal/installation of each part, the procedure is shown with the procedural step No. in the illustration.
- Precautions and key points for disassembly and reassembly of parts are described as **points**. In the explanation for each point, detailed operation method, information, standard and precautions are described.

Description Example

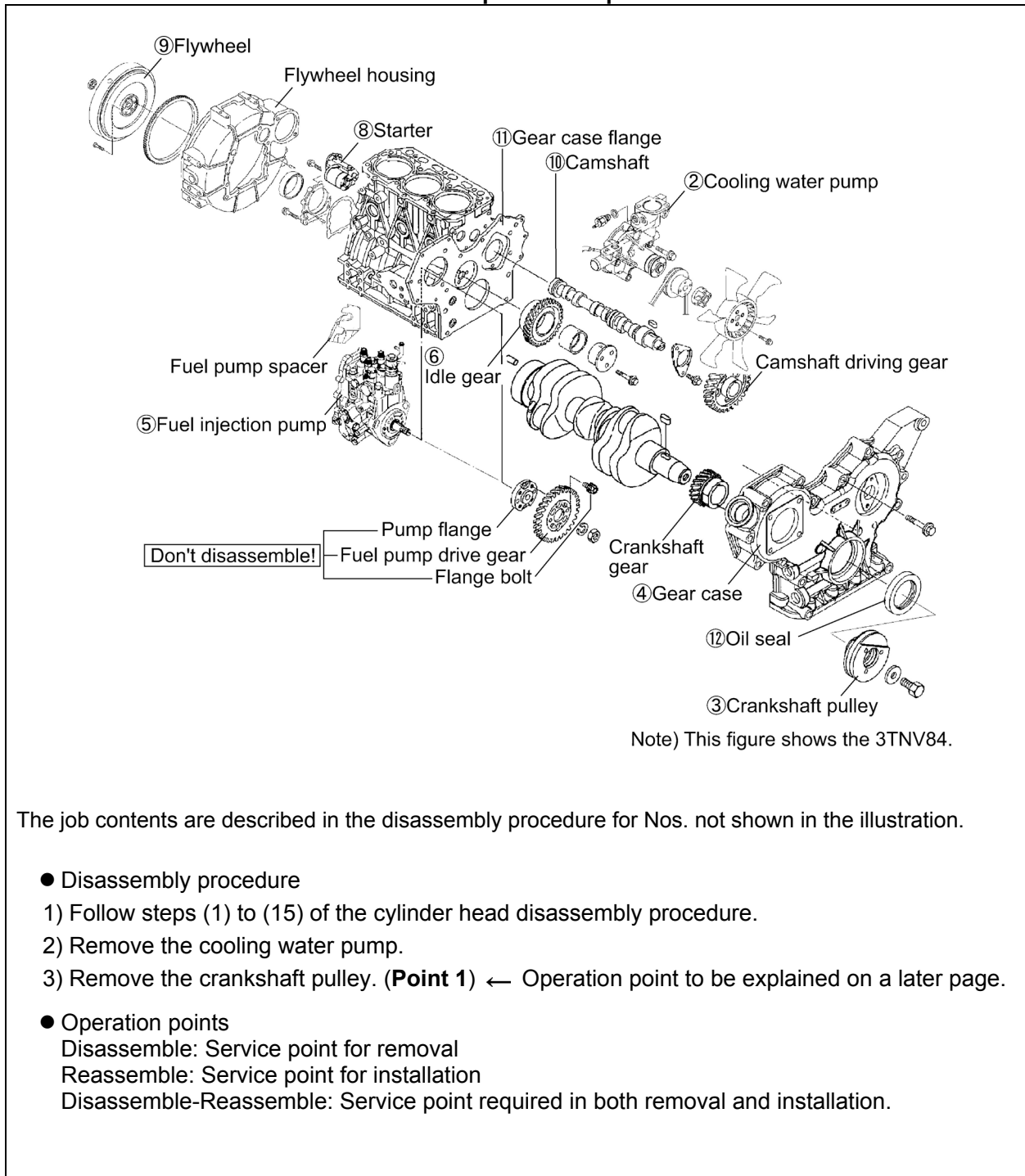

The job contents are described in the disassembly procedure for Nos. not shown in the illustration.

● Disassembly procedure

- 1) Follow steps (1) to (15) of the cylinder head disassembly procedure.
- 2) Remove the cooling water pump.
- 3) Remove the crankshaft pulley. (**Point 1**) ← Operation point to be explained on a later page.

● Operation points

Disassemble: Service point for removal

Reassemble: Service point for installation

Disassemble-Reassemble: Service point required in both removal and installation.

- Contents omitted in this manual

Though the following jobs are omitted in the explanation in this manual, they should be conducted in actual work:

- 3) Jacking up and lifting
- 4) Cleaning and washing of removed parts as required
- 5) Visual inspection

(3) Definition of Terms

[NOTICE]: Instruction whose negligence is very likely to cause an accident. Always observe it.

Standard: Allowable range for inspection and adjustment.

Limit: The maximum or minimum value that must be satisfied during inspection or adjustment.

(4) Abbreviations

Abbreviation	Meaning	Abbreviation	Meaning
Assy	assembly	T.D.C.	top dead center
Sub-Assy	sub-assembly	B.D.C.	bottom dead center
a.T.D.C	after top dead center	OS	oversize
b.T.D.C	before top dead center	US	undersize
STD	Standard	Min ⁻¹	revolutions per minute
IN	Intake	PS	Output (metric horsepower)
EX	Exhaust	T	Bolt/nut tightening torque

CONTENTS

1. General	1
1.1 Engine Nomenclature	1
1.2 Specifications.....	1
1.3 Fuel Oil, Lubricating Oil and Cooling Water.....	14
1.3.1 Fuel oil.....	14
1.3.2 Lubricating oil	15
1.3.3 Cooling water	15
1.4 Engine External Views.....	16
1.5 Structural Description	17
1.6 Exhaust gas emission regulation.....	18
1.6.1 The Emission Standard in USA	18
1.6.2 Engine identification	19
1.6.3 Guarantee Conditions for the EPA Emission Standard	20
2. Inspection and Adjustment	22
2.1 Periodic Maintenance Schedule	22
2.2 Periodic Inspection and Maintenance Procedure	23
2.2.1 Check before Daily Operation	23
2.2.2 inspection after initial 50 hours operation	25
2.2.3 Inspection every 50 hours	28
2.2.4 Inspection every 250 hours or 3 months	32
2.2.5 Inspection every 500 hours or 6 months	35
2.2.6 Inspection every 1,000 hours or one year	37
2.2.7 Inspection every 2000 hours or 2 years	46
2.3 Adjusting the no-load maximum or minimum speed.....	49
2.4 Sensor Inspection	50
2.4.1 Oil pressure switch	50
2.4.2 Thermo switch	50
2.5 Water leak check in cooling water system.....	50
2.6 Radiator cap inspection	51
2.7 Thermostat Inspection	51
2.8 Adjusting Operation	52
2.9 Long storage.....	52
3. TROUBLESHOOTING	53
3.1 Preparation before troubleshooting	53
3.2 Quick Reference Table for Troubleshooting	54
3.3 Troubleshooting by measuring Compression Pressure.....	57

4. Disassembly, Inspection and Reassembly of Engines	59
4.1 Complete disassembly and reassembly	59
4.1.1 Introduction	59
4.1.2 Special service tools	60
4.1.3 Complete disassembly	65
4.1.4 Precautions before and during reassembly	69
4.1.5 Adjusting operation	69
4.2 Cylinder Head: Disassembly, Inspection and Reassembly.....	70
4.2.1 Components (2-valve cylinder head).....	70
4.2.2 Disassembly procedure:	70
4.2.3 Reassembly procedure:	71
4.2.4 Servicing points	72
4.2.5 Parts Inspection and measurement.....	76
4.2.6 Valve seat correction	80
4.2.7 Valve guide replacement	81
4.2.8 Valve stem seal replacement.....	82
4.3 Gear Train and Camshaft	83
4.3.1 Components	83
4.3.2 Disassembly procedure:	83
4.3.3 Reassembly procedure:	83
4.3.4 Servicing points	84
4.3.5 Parts inspection and measurement	87
4.3.6 Oil seal replacement (Gear case side)	89
4.3.7 Camshaft bushing replacement.....	89
4.4 Cylinder Block.....	90
4.4.1 Components	90
4.4.2 Disassembly procedure:	90
4.4.3 Reassembly procedure:	90
4.4.4 Servicing points	91
4.4.5 Parts inspection and measurement	95
4.4.6 Cylinder bore correction	106
4.4.7 Piston pin bushing replacement	107
4.4.8 Oil seal replacement (Flywheel housing side)	107

5. LUBRICATION SYSTEM	108
5.1 Lubrication System Diagram	108
5.2 Trochoid Pump Components	109
5.3 Disassembly(Reverse the procedure below for assembly)	109
5.4 Servicing Points	109
5.5 Parts Inspection and Measurement.....	110
5.5.1 Trochoid pump inspection and measurement.....	110
6. COOLING SYSTEM.....	112
6.1 Cooling Water System	112
6.2 Cooling Water Pump Components	112
6.3 Disassembly (Reverse the procedure below for assembly)	113
6.4 Servicing Points	113
7. FUEL INJECTION PUMP/GOVERNOR.....	114
7.1 Introduction	114
7.2 Fuel Injection Pump.....	114
7.2.1 Fuel system diagram	114
7.2.2 External view and components.....	115
7.2.3 Disassembly procedure:	115
7.2.4 Assembly procedure.....	116
7.2.5 Servicing points	116
8. TURBOCHARGER: Disassembly, inspection and reassembly.....	118
8.1 Structure and Functions.....	118
8.1.1 Main specifications	118
8.1.2 Construction	118
8.1.3 Structural and functional outline	119
8.1.4 Components	120
8.2 Service Standards and Tightening Torque	121
8.2.1 Service standards.....	121
8.2.2 Tightening torque.....	122
8.3 Periodic Inspection Procedure.....	123
8.3.1 Periodic inspection intervals	123
8.3.2 Inspection procedure.....	124
8.3.3 Waste gate valve adjustment procedure	125
8.4 Disassembly Procedure.....	127
8.4.1 Preparation for disassembly	127
8.4.2 Inspection before disassembly	128
8.4.3 Disassembly	128

8.5 Washing and Inspection procedure	130
8.5.1 Washing	130
8.5.2 Inspection procedure.....	131
8.6 Reassembly Procedure	134
8.6.1 Preparation for reassembly.....	134
8.6.2 Reassembly	134
8.7 Handling after Disassembly and Reassembly	137
8.7.1 Instructions for turbocharger installation.....	137
8.8 Troubleshooting	138
8.8.1 Excessively exhaust smoke	138
8.8.2 White smoke generation.....	138
8.8.3 Sudden oil decrease.....	139
8.8.4 Decrease in output	139
8.8.5 Poor (slow) response (starting) of turbocharger	139
8.8.6 Abnormal sound or vibration.....	139
9. STARTING MOTOR.....	140
9.1 For 4TNV94L/ 98	140
9.1.1 Specifications	140
9.1.2 Components	141
9.1.3 Troubleshooting.....	142
9.1.4 Names of parts and disassembly procedure	143
9.1.5 Inspection and Maintenance	147
9.1.6 Service standards.....	152
9.1.7 Assembly.....	153
9.1.8 Characteristic test.....	155
9.2 For 4TNV106(T)	156
9.2.1 Specifications	156
9.2.2 Congiguration drawing	156
9.2.3 Troubleshooting	157
9.2.4 Component names and disassembly procedure	158
9.2.5 Disassembly procedure.....	159
9.2.6 Inspection and maintenance	167
9.2.7 Assembly.....	173
9.2.8 Adjustment	174
9.2.9 Service standards.....	175

10. ALTERNATOR	176
10.1 The 40A Alternator for 3TNV84 and other models.....	176
10.1.1 Components.....	176
10.1.2 Specifications.....	177
10.1.3 Wiring diagram.....	177
10.1.4 Standard output characteristics.....	178
10.1.5 Inspection.....	178
10.2 Troubleshooting.....	179
11. ELECTRIC WIRING	180
11.1 Electric Wiring Diagram.....	180
11.2 PRECAUTION ON ELECTRIC WIRING.....	181
11.2.1 Alternator.....	181
11.2.2 Starter.....	182
11.2.3 Current limiter.....	183
11.2.4 Section area and resistance of electric wire.....	184
12. SERVICE STANDARDS	185
12.1 Engine Tuning.....	185
12.2 Engine Body.....	186
12.2.1 Cylinder head.....	186
12.2.2 Gear train and camshaft.....	189
12.2.3 Cylinder block.....	190
12.3 Lubricating Oil System (Trochoid Pump).....	195
12.3.1 Outside clearance of outer rotor.....	195
12.3.2 Side clearance of outer rotor.....	195
12.3.3 Inside clearance of inner rotor.....	195
12.3.4 Rotor shaft clearance.....	195
13. TIGHTENING TORQUE for BOLTS and NUTS	196
13.1 Tightening Torques for Main Bolts and Nuts.....	196
13.2 Tightening Torques for Standard Bolts and Nuts.....	197

1. General

1.1 Engine Nomenclature

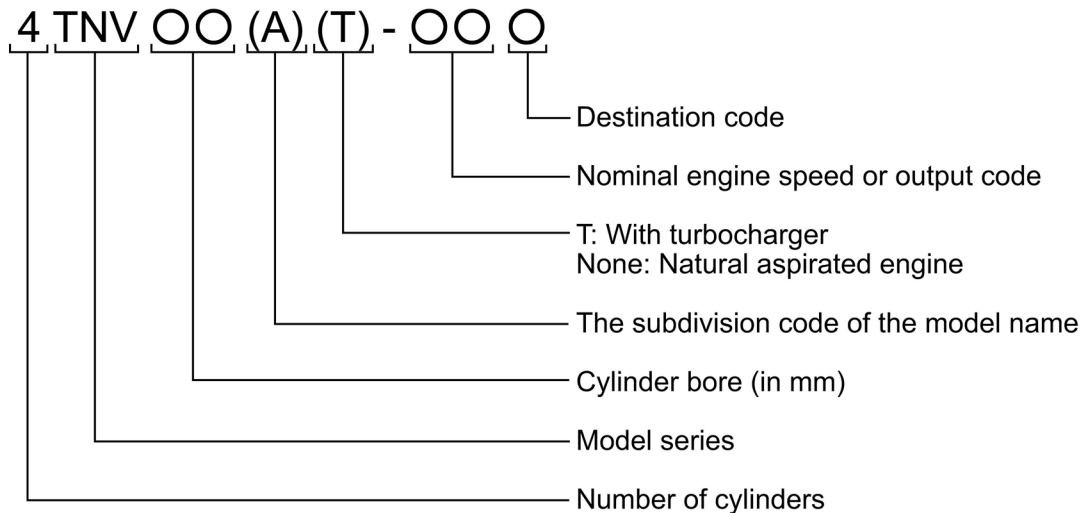

The engine specification class

Classification	Load	Engine speed	Available engine speed (min ⁻¹)
CL	Constant load	Constant speed	1500/1800
VM	Variable load	Variable speed	2000-3000

※ The engine specification class (CL or VM) is described in the specifications table.

1.2 Specifications

NOTE:

- 1) The information described in the engine specifications tables (the next page and after) is for "standard" engine. To obtain the information for the engine installed in each machine unit, refer to the manual provided by the equipment manufacturer.
- 2) Engine rating conditions are as follows (SAE J1349, ISO 3046/1)
 - Atmospheric condition: Room temp. 25°C, Atmospheric press. 100 kPa (750mm Hg), Relative humidity 30%
 - Fuel temp: 25°C (Fuel injection pump inlet)
 - With cooling fan, air cleaner, exhaust silencer.
 - After running-in hours. Output allowable deviation: ±3%

(1) 3TNV82A

Engine name		Unit	3TNV82A								
Engine specification class		-	CL	VM							
Type		-	Vertical, in-line, 4-cycle, water-cooled diesel engine								
Combustion chamber		-	Direct injection								
Number of cylinders		-	3								
Cylinder bore×stroke		mm×mm	82×84								
Displacement		L	1.331								
Continuous rating	Revolving speed	Min ⁻¹	1500	1800	-						
	Output	kW (hp)	9.9 (13.5)	12.0 (16.3)	-						
Rated output	Revolving speed	Min ⁻¹	1500	1800	2000	2200	2400	2500	2600	2800	3000
	Output	kW (hp)	11.0 (14.9)	13.2 (17.9)	14.6 (19.9)	16.0 (21.8)	17.5 (23.8)	18.2 (24.8)	19.0 (25.8)	20.4 (27.8)	21.9 (29.8)
Max. no-load speed (±25)		min ⁻¹	1600	1895	2180	2375	2570	2675	2780	2995	3180
Ignition order		-	1-3-2-1(No.1 cylinder on flywheel side)								
Power take off		-	Flywheel								
Direction of rotation		-	Counterclockwise (viewed from flywheel)								
Cooling system		-	Radiator								
Lubrication system		-	Forced lubrication with trochoid pump								
Starting system		-	Electric								
Applicable fuel		-	Diesel oil-ISO 8217 DMA, BS 2869 A1 or A2 (Cetane No.45 min.)								
Applicable lubricant		-	API grade class CD or CF								
Lubricant capacity (oil pan) *	Total	L	3.6						5.5		
	Effective	L	1.2						2.2		
Coolant water capacity (engine only)		L	1.8								
Engine Dimensions ** (with flyw Crankshaft V pulley diameter & heel housing)	Overall length	mm	553			528					
	Overall width	mm	489								
	Overall height	mm	565								
Engine mass (dry) ** (with flywheel housing)		kg	138			128					
Cooling fan (std.)		mm	335 mm O/D, 6 blades pusher type								
Fun V pulley diameter (std.)		mm	120×90			110×110					

* Engine oil capacity may differ from the above depending on an engine installed on a machine unit.

** Engine mass and dimensions without radiator

(2) 3TNV84

Engine name		Unit	3TNV84								
Engine specification class		-	CL	VM							
Type		-	Vertical, in-line, 4-cycle, water-cooled diesel engine								
Combustion chamber		-	Direct injection								
Number of cylinders		-	3								
Cylinder bore×stroke		mm×mm	84×90								
Displacement		L	1.496								
Continuous rating	Revolving speed	Min ⁻¹	1500	1800	-						
	Output	kW (hp)	11.3 (15.3)	13.5 (18.3)	-						
Rated output	Revolving speed	Min ⁻¹	1500	1800	2000	2200	2400	2500	2600	2800	3000
	Output	kW (hp)	12.4 (16.8)	14.8 (20.1)	16.4 (22.3)	18.1 (24.6)	19.7 (26.8)	20.5 (27.9)	21.3 (29.0)	23.0 (31.3)	24.6 (33.5)
Max. no-load speed (±25)		min ⁻¹	1600	1895	2180	2400	2590	2690	2810	2995	3210
Ignition order		-	1-3-2-1(No.1 cylinder on flywheel side)								
Power take off		-	Flywheel								
Direction of rotation		-	Counterclockwise (viewed from flywheel)								
Cooling system		-	Radiator								
Lubrication system		-	Forced lubrication with trochoid pump								
Starting system		-	Electric								
Applicable fuel		-	Diesel oil-ISO 8217 DMA, BS 2869 A1 or A2 (Cetane No.45 min.)								
Applicable lubricant		-	API grade class CD								
Lubricant capacity (oil pan) *	Total	L	6.7								
	Effective	L	1.9								
Coolant water capacity (engine only)		L	1.8								
Engine dimensions ** (with flywheel housing)	Overall length	mm	589	564							
	Overall width	mm	486								
	Overall height	mm	622								
Engine mass (dry) ** (with flywheel housing)		kg	161	155							
Cooling fan (std.)		mm	335 mm O/D, 6 blades pusher type								
Crankshaft V pulley diameter & Fun V pulley diameter (std.)		mm	120×90	110×110							

* Engine oil capacity may differ from the above depending on an engine installed on a machine unit.

** Engine mass and dimensions without radiator

(3) 3TNV84T

Engine name		Unit	3TNV84T								
Engine specification class		-	CL	VM							
Type		-	Vertical, in-line, 4-cycle, water-cooled diesel engine								
Combustion chamber		-	Direct injection								
Number of cylinders		-	3								
Cylinder borexstroke		mmxmm	84x90								
Displacement		L	1.496								
Continuous rating	Revolving speed	Min ⁻¹	1500	1800	-						
	Output	kW (hp)	14.0 (19.0)	16.5 (22.5)	-						
Rated output	Revolving speed	Min ⁻¹	1500	1800	2000	2200	2400	2500	2600	2800	3000
	Output	kW (hp)	15.8 (21.5)	18.8 (25.5)			25.0 (34.0)	25.9 (35.2)	26.8 (36.5)	29.1 (39.5)	30.9 (42.0)
Max. no-load speed (±25)		min ⁻¹	1600	1895			2590	2700	2810	2995	3210
Ignition order		-	1-3-2-1(No.1 cylinder on flywheel side)								
Power take off		-	Flywheel								
Direction of rotation		-	Counterclockwise (viewed from flywheel)								
Cooling system		-	Radiator								
Lubrication system		-	Forced lubrication with trochoid pump								
Starting system		-	Electric								
Applicable fuel		-	Diesel oil-ISO 8217 DMA, BS 2869 A1 or A2 (cetane No.45 min.)								
Applicable lubricant		-	API grade class CD or CF								
Lubricant capacity (oil pan) *	Total	L	6.7								
	Effective	L	1.9								
Coolant water capacity (engine only)		L	2.0								
Engine dimensions ** (with flywheel housing)	Overall length	mm	589	564							
	Overall width	mm	486								
	Overall height	mm	622								
Engine mass (dry) ** (with flywheel housing)		kg	161	155							
Cooling fan (std.)		mm	350 mm O/D, 6 blades pusher type								
Crankshaft V pulley diameter & Fun V pulley diameter (std.)		mm	120x90	110x110							

* Engine oil capacity may differ from the above depending on an engine installed on a machine unit.

** Engine mass and dimensions without radiator