

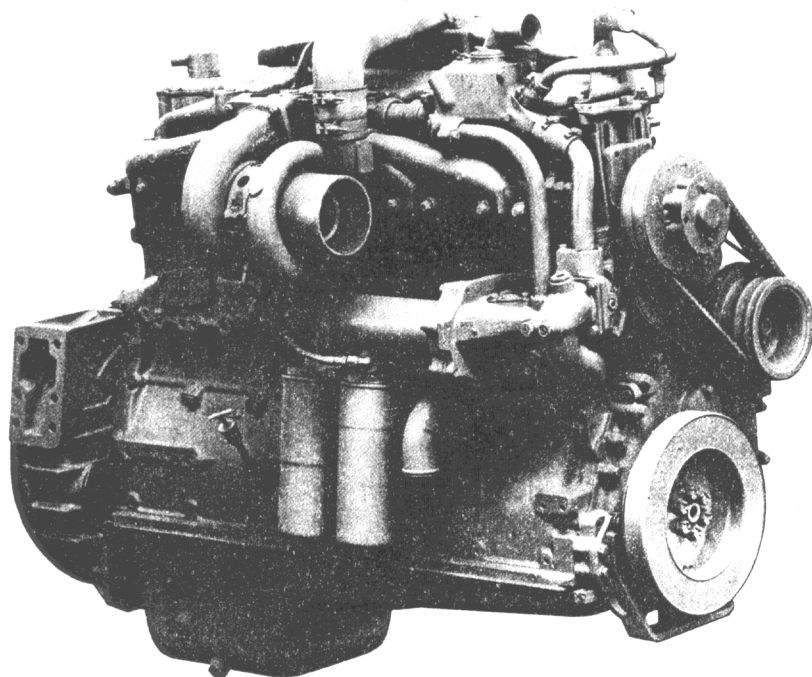

Troubleshooting and Repair Manual Big Cam III and Big Cam IV, NT 855 Engines

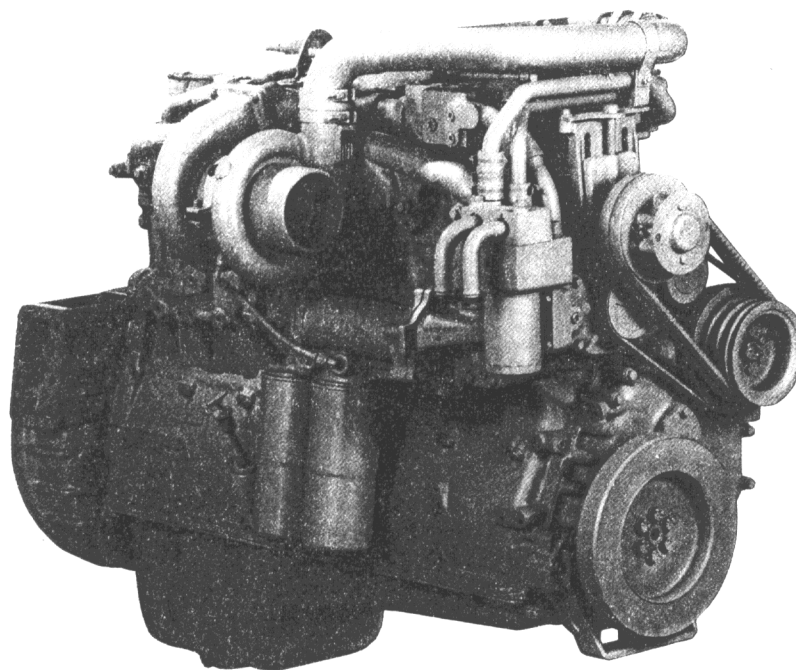

Big Cam III



Big Cam IV

Foreword

This manual provides instructions for troubleshooting and repairing the NT 855 engine in the chassis. Component and assembly rebuild procedures are provided in the NT 855 Engine Shop Manual. Refer to page 2 in the Introduction for instructions on how to use this manual.

The manual is organized to guide a service technician through the logical steps of identifying and correcting problems related to the engine.

This manual does **not** cover vehicle or equipment problems. Consult the vehicle or equipment manufacturer for repair procedures.

The repair procedures used in this manual are recommended by Cummins Engine Company, Inc. Some service procedures require the use of special service tools. Use the correct tools as described.

The information, specifications, and recommended repair procedures in this publication are based on the information in effect at the time this manual was printed. Cummins Engine Company, Inc. reserves the right to make changes at any time without notice.

Reporting of errors, omissions, and recommendations for improving this publication by the user is encouraged. Please send all suggestions and comments to:

CUMMINS ENGINE COMPANY, INC.

Box 3005

Columbus, Indiana 47202-3005

ATTENTION: NT 855 Product Service & Support

Mail Code - 80206

Table of Contents

	Section	Page
Introduction.....	I	1
Engine Identification	E	1
- General Engine Specifications		3
- Engine Diagrams		5
Troubleshooting	T	1
- Procedures and Techniques		1
- Symptoms List		2
- Symptoms Cause and Corrections Charts.....		3
Engine Systems Repair		
- Cooling	1	1
- Lubricating Oil	2	1
- Combustion Air	3	1
- Compressed Air	4	1
- Fuel	5	1
- Electrical.....	6	1
- Base Engine Components.....	7	1
Engine Testing ("In-Chassis")	8	1
Engine - Remove and Install	9	1
Engine Component Specifications	10	1
Alphabetical Index	11	1
Additional Service Literature	12	1
Accessory Component Manufacturers	13	1

Section I - Introduction

Table of Contents

	Page No.
About the Manual.....	2
How to Use the Manual	2
Symbols	3
Illustrations	7
Definition of Terms	8
General Repair Instructions	9
General Cleaning Instructions	10

About the Manual

This NT 855 Troubleshooting and Repair Manual is intended to aid in determining the cause of engine-related problems and to provide recommended repair procedures. The manual is divided into sections. Some sections contain reference numbers and procedure numbers. The reference numbers provide general information, specifications, diagrams, and service tools, where applicable. The procedure numbers describe specific repair procedures and are referred to in the Troubleshooting Logic Charts.

How to Use the Manual

The manual is organized to provide an easy flow from problem identification to problem correction. A list of troubleshooting symptoms containing the most common engine problems is on page 2 in the Troubleshooting Section. Complete the following steps to locate and correct the problem:

- (STEP 1.) Locate the symptom on the list.
Reference is made to the page number where the "Troubleshooting Logic Chart" is found.
- (STEP 2.) The left column of the "Troubleshooting Logic Chart" indicates a probable cause, starting at the top with the simplest and easiest to repair, and continuing downward to the most difficult.
The right column provides a brief description of the corrective action with a procedure number reference for the repair procedure.
- (STEP 3.) Locate the probable cause in the left column, and then turn to the procedure referenced in the right column.
The repair procedures are listed by system (cooling, lubricating oil, combustion air, compressed air, fuel, electrical, and base engine components).
- (STEP 4.) The Troubleshooting Logic Charts are based on the following assumptions:
1. The engine has been installed according to the manufacturer's specifications.
 2. The easiest repairs are done first.
 3. "Generic" solutions to cover problems with the most common applications and OEM's (Original Equipment Manufacturer).

Generic Symbols

The following symbols have been used in this manual to help communicate the intent of the instructions. When one of the symbols appears, it conveys the meaning defined below:



WARNING - Serious personal injury or extensive property damage can result if the warning instructions are **not** followed.



CAUTION - Minor personal injury can result or a part, an assembly, or the engine can be damaged if the caution instructions are **not** followed.



Indicates a **REMOVAL** or **DISASSEMBLY** step.



Indicates an **INSTALLATION** or **ASSEMBLY** step.



INSPECTION is required.



CLEAN the part or assembly.



PERFORM a mechanical or time **MEASUREMENT**.



LUBRICATE the part or assembly.



Indicates that a **WRENCH** or **TOOL SIZE** will be given.



TIGHTEN to a specific torque.



PERFORM an electrical **MEASUREMENT**.



Refer to another location in this manual or another publication for additional information.

Simbolos Usados En Este Manual

Los símbolos siguientes son usados en este manual para clarificar el proceso de las instrucciones. Cuando aparece uno de estos símbolos, su significado se especifica en la parte inferior.



ADVERTENCIA - Serios daños personales o daño a la propiedad puede resultar si las instrucciones de Advertencia **no** se consideran.



PRECAUCION - Daños menores pueden resultar, o de piezas del conjunto o el motor puede averiarse si las instrucciones de Precaución **no** se siguen.



Indica un paso de **REMOCION** o **DESMONTAJE**.



Indica un paso de **INSTALACION** o **MONTAJE**.



Se requiere **INSPECCION**.



LIMPIESE la pieza o el montaje.



EJECUTESE una **MEDICION** mecánica o del tiempo.



LUBRIQUESE la pieza o el montaje.



Indica que se dará una **LLAVE DE TUERCAS** o el **TAMAÑO DE HERRAMIENTA**.



APRIETESE hasta un par torsor específico.



EJECUTESE una **MEDICION** eléctrica.



Para información adicional refiérase a otro emplazamiento de este manual o a otra publicación anterior.

Symbole

In diesem Handbuch werden die folgenden Symbole verwendet, die wesentliche Funktionen hervorheben. Die Symbole haben folgende Bedeutung:



WARNUNG - Wird die Warnung **nicht** beachtet, dann besteht erhöhte Unfall- und Beschädigungsgefahr.



VORSICHT - Werden die Vorsichtsmassnahmen **nicht** beachtet, dann besteht Unfall- und Beschädigungsgefahr.



AUSBAU bzw. **ZERLEGEN**.



EINBAU bzw. **ZUSAMMENBAU**.



INSPEKTION erforderlich.



Teil oder Baugruppe **REINIGEN**.



DIMENSION - oder **ZEITMESSUNG**.



Teil oder Baugruppe **ÖLEN**.



WERKZEUGGRÖSSE wird angegeben.



ANZUG auf vorgeschriebenes Drehmoment erforderlich.



Elektrische **MESSUNG DURCHFÜHREN**.



Weitere Informationen an anderer Stelle bzw. in anderen Handbüchern.

Symboles Utilises Dans Ce Manuel

Les symboles suivants sont utilisés dans ce manuel pour aider à communiquer le but des instructions. Quand l'un de ces symboles apparaît, il évoque le sens défini ci-dessous:



AVERTISSEMENT - De graves lésions corporelles ou des dommages matériels considérables peuvent survenir si les instructions données sous les rubriques "Avertissement" **ne** sont **pas** suivies.



ATTENTION - De petites lésions corporelles peuvent survenir, ou bien une pièce, un ensemble ou le moteur peuvent être endommagés si les instructions données sous les rubriques "Attention" **ne** sont **pas** suivies.

sécurité p



Indique une opération de **DEPOSE**.



Indique une opération de **MONTAGE**.



L'INSPECTION est nécessaire.



NETTOYER la pièce ou l'ensemble.



EFFECTUER une **MESURE** mécanique ou de temps.



GRAISSER la pièce ou l'ensemble.



Indique qu'une **DIMENSION DE CLE** ou **D'OUTIL** sera donnée.



SERRER à un couple spécifique.



EFFECTUER une **MESURE** électrique.



Se reporter à un autre endroit dans ce manuel ou à une autre publication pour obtenir des informations plus complètes.

Illustrations

The illustrations used in the "Repair Sections" of this manual are intended to give an example of a problem and to show what to look for and where the problem can be found. Some of the illustrations are "generic" and might not look exactly like the engine or parts used in your application. The illustrations may contain symbols to indicate an action required and an acceptable or not acceptable condition.

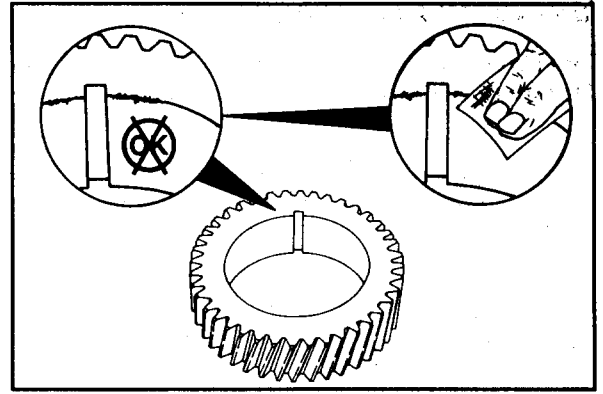

The illustrations are intended to show repair or replacement procedures with the engine "in-chassis." The illustration can differ from your application, but the procedure given will be the same.

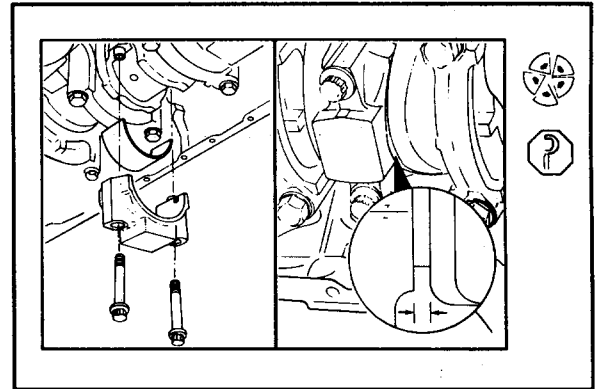

Definition of Terms

The following is a list of guidelines for each procedure in the "Repair Sections" of the Troubleshooting and Repair Manual. The procedure will be given first, followed by a definition of the step or steps involved.

Check - Examine a component or system for damage, excessive wear, accuracy, safety, or performance.

Inspect - Examine a component or dimension to make sure it meets the required specifications.

Test - Check or compare the performance of a component or system to established specifications.

Adjust - Complete the necessary steps to set or adjust the component, assemblies, or system in the required setting or position.

Visually Inspect - Look for any obvious damage or problem.

Remove - Take off a component or assembly.

Clean - Remove dirt, grease, or other contamination.

Disassemble - Take apart the component or assembly.

Repair - Restore a component or assembly to a serviceable condition within the established specifications.

NOTE: Only the easiest and simplest repairs will be made to a component or assembly. If a component or assembly **must** be rebuilt, it **must** be replaced with a new or Cummins Diesel ReCon®, Inc. replacement or be rebuilt at a Cummins authorized repair location.

Replace - Install a new, correctly rebuilt, or Cummins Diesel ReCon®, Inc. component or assembly in place of the one which is removed.

Install - Place a component or assembly in the correct position.

Star Pattern Torque Sequence -

General Repair Instructions

The NT 855 engine incorporates the latest diesel technology; yet, it is designed to be repaired using normal repair practices performed to quality standards.



Warning: Cummins Engine Company, Inc. does not recommend/authorize any modifications or repairs to engines or components except for those detailed in Cummins Service Information. In particular, unauthorized repair to safety-related components can cause personal injury. Below is a partial listing of components classified as safety-related:

Air Compressor
Air Controls
Air Shutoff Assemblies
Balance Weights
Cooling Fan
Fan Hub Assembly
Fan Mounting Bracket(s)
Fan Mounting Capscrews
Fan Hub Spindle
Flywheel
Flywheel Crankshaft Adapter
Flywheel Mounting Capscrews
Fuel Shutoff Assemblies
Fuel Supply Tubes
Lifting Brackets
Throttle Controls
Turbocharger Compressor Casing
Turbocharger Oil Drain Line(s)
Turbocharger Oil Supply Line(s)
Turbocharger Turbine Casing
Vibration Damper Mounting Capscrews

- **Follow All Safety Instructions Noted in the Procedures.**
 - Follow the manufacturer's recommendations for cleaning solvents and other substances used during the repair of the engine. **Always** use good safety practices with tools and equipment.
- **Provide A Clean Environment and Follow the Cleaning Instructions Specified in the Procedures**
 - The engine and its components **must** be kept clean during any repair. Contamination of the engine and components will cause premature wear.
- **Perform the Inspections Specified in the Procedures.**
- **Replace all Components or Assemblies Which are Damaged or Worn Beyond the Specifications**
- **Use Genuine Cummins New or ReCon® Service Parts and Assemblies**
 - The assembly instructions have been written to use again as many components and assemblies as possible. When it is necessary to replace a component or assembly, the procedure is based on the use of new Cummins or Cummins ReCon® components. All of the repair services described in this manual are available from all Cummins Distributors and most Dealer locations.
- **Follow The Specified Disassembly and Assembly Procedures to Avoid Damage to the Components.**

Complete rebuild instructions are available in the NT 855 Engine Shop Manual, which can be ordered or purchased from a Cummins authorized repair location. Refer to page 1 in the Additional Service Literature Section for ordering instructions.

General Cleaning Instructions

Solvent and Acid Cleaning



Several solvent and acid-type cleaners can be used to clean the engine parts. **Cummins Engine Company, Inc. does not recommend any specific cleaners. Always** follow the cleaner manufacturer's instructions.

Experience has shown that the best results can be obtained using a cleaner that can be heated to 90 to 95 degrees Celsius [180 to 200 degrees Fahrenheit]. A cleaning tank that provides a constant mixing and filtering of the cleaning solution will give the best results.

Remove all the gasket material, O-rings, and the deposits of sludge, carbon, etc., with a wire brush or scraper before putting the parts in a cleaning tank. Be careful **not** to damage any gasket surfaces. When possible, steam clean the parts before putting them in the cleaning tank.



Warning: The use of acid can be extremely dangerous to personnel and can damage the machinery. Always provide a tank of strong soda water as a neutralizing agent.

Rinse all of the parts in hot water after cleaning. Dry completely with compressed air. Blow the rinse water from all of the capscrew holes and the oil drillings.

If the parts are **not** to be used immediately after cleaning, dip them in a suitable rustproofing compound. The rustproofing compound **must** be removed from the parts before installation on the engine.

Steam Cleaning



Steam cleaning can be used to remove all types of dirt that can contaminate the cleaning tank. It is a good way to clean the oil drillings.



Warning: Wear protective clothing to prevent personal injury from the high pressure and extreme heat.

Do **not** steam clean the following parts:

1. Electrical Components
2. Wiring
3. Injectors
4. Fuel Pump
5. Belts and Hoses
6. Bearings

Glass or Plastic Bead Cleaning



Glass or plastic bead cleaning can be used on many engine components to remove carbon deposits. The cleaning process is controlled by the size of the glass or plastic beads, the operating pressure, and the cleaning time.



Caution: Do not use glass or plastic bead cleaning on aluminum piston skirts or ring grooves. Small particles of glass or plastic will embed in the aluminum and result in premature wear. Valves, turbocharger shafts, etc., can also be damaged. Follow the cleaning directions listed in the procedures.

Follow the equipment manufacturer's cleaning instructions. The following guidelines can be used to adapt to the manufacturer's instructions:

1. Bead size: Use U.S. size No. 70 for piston domes.
Use U.S. size No. 60 for general purpose cleaning.
2. Operating Pressure: Use 620 kPa [90 psi] for general purpose cleaning.
3. Steam clean or wash the parts with solvent to remove all of the foreign material and glass or plastic beads after cleaning. Rinse with hot water. Dry with compressed air.
4. Do **not** contaminate the wash tanks with glass or plastic beads.

Section E - Engine Identification

Table of Contents

	Page No.
Engine Identification	2
General Engine Specifications	3
Engine Diagrams	5

Engine Identification

The model name provides the following engine data:

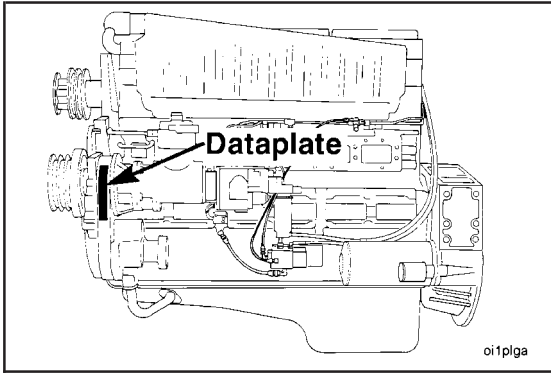
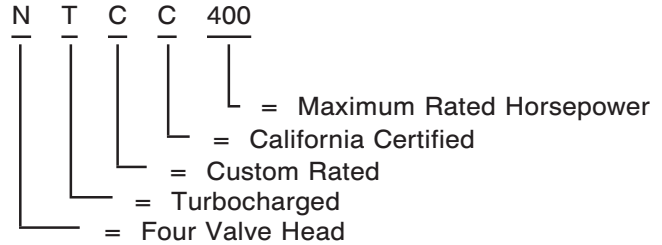
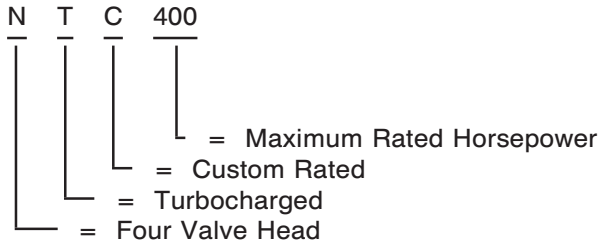

Engine Dataplate

The engine dataplate shows specific information about your engine. The engine serial number (1) and the Control Parts List (CPL) (2) provide information for ordering parts and service needs.

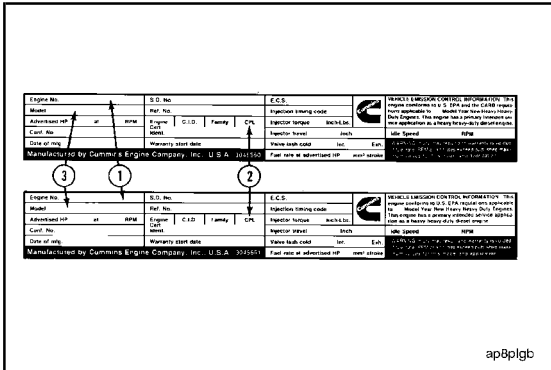

Always record the serial number (1) of the engine, the CPL (Control Parts List) number (2), and the engine model number (3) on all orders for parts. This information is important for fuel pump calibration and correct identification of parts.

NOTE: The engine dataplate **must not** be changed unless approved by Cummins Engine Company, Inc.

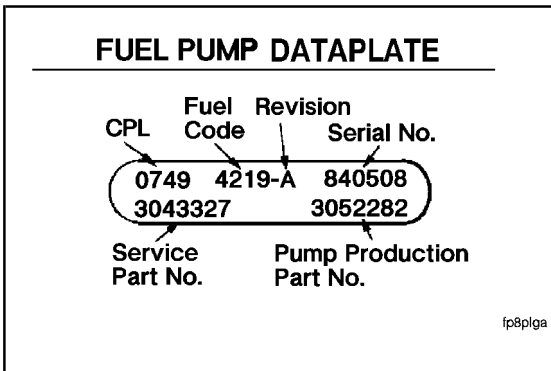

Fuel Pump Dataplate (Nameplate)

The fuel pump dataplate is located on the top of the fuel pump. It provides information for fuel pump calibration.

Engine Specifications

General Engine Data

Horsepower	179 kw (240 BHP) to 354 kw (475 BHP)
Engine Speed@ Maximum Output	
Standard Rating (RPM)	2100
Formula Rating (RPM).....	1800
Bore and Stroke	140 mm [5.5 in.] X 152 mm [6.0 in.]
Displacement	14.0 liters [855 cu. in.]
Compression Ratio	13.5:1 to 17.2:1
Firing Order.....	1-5-3-6-2-4
Engine Weight (With Standard Accessories)	
Dry Weight.....	1126 kg [2480 lb.] to 1221 kg [2690 lb.]
Wet Weight.....	1180 kg [2600 lb.] to 1276 kg [2810 lb.]

Air Induction System

Maximum allowable turbocharged intake restriction	64 cm H ₂ O [25 in. H ₂ O]
Maximum allowable naturally aspirated and Fleet 270 intake restriction	51 cm H ₂ O [20 in. H ₂ O]

Lubrication System

Oil pressure at idle (minimum allowable)	70 kPa [10 psi] minimum
At no load governed speed	240-310 kPa [35-45 psi]
Oil capacity of standard engine:	
Bypass filter	2.8 liters [0.75 U.S. gal.]
Full flow filter	3.5 liters [0.93 U.S. gal.]
Combo filter	3.9 liters [1.04 U.S. gal.]
Oil pan capacity (high-low).....	36-28 liters [9.5-7.5 U.S. gal.]
Total system capacity including filters	42 liters [11.0 U.S. gal.]

Engine Specifications (Cont'd.)

Cooling System

Coolant capacity (engine only)	21 liters [22 U.S. quarts]
Standard modulating thermostat range	
Conventional aftercooling	82-93°C [180-200°F]
Optimized aftercooling	79-91°C [175-195°F]
Maximum coolant cylinder block pressure (pressure cap removed)	350 kPa [50 psi]
Maximum allowable operating temperature	100°C [212°F]
Maximum allowable operating temperature for NTC-444	104°C [220°F]
Minimum recommended operating temperature	70°C [158°F]
Minimum recommended pressure cap	50 kPa [7 psi]

Exhaust System

Maximum allowable back pressure imposed by piping and silencer	1000 mm H ₂ O [40 in. H ₂ O]
Maximum bending movement to turbocharger flange	27 N•m [20 ft-lb]
Exhaust pipe size (normally acceptable inside diameter except NTC 475)	127 mm [5 in.]
NTC 475	152 mm [6 in.]

Fuel System

Maximum allowable restriction to pump:	
With clean filter	100 mm Hg [4 in. Hg]
With dirty filter	200 mm Hg [8 in. Hg]
Maximum allowable fuel return line restriction	
Without check valves	64 mm Hg [2.5 in. Hg]
With check valves and/or overhead tanks	165 mm Hg [6.5 in. Hg]
Minimum fuel tank vent capability	0.85 m ³ /h [30 ft ³ /hr]

Electrical System

Battery Size	Ambient Temperatures			
	-18°C (0°F)		0°C (32°F)	
	Cold Cranking Amperes	Reserve Capacity *	Cold Cranking Amperes	Reserve Capacity
12 Volt	1800	640	1280	480
24 Volt **	900	320	640	240

* The number of plates within a given battery size determine reserve capacity. Reserve capacity determines the length of time sustained cranking can occur.

** CCA ratings are based on two 12-volt batteries in series.

Engine Diagrams

The following drawings contain information about engine components, filter locations, drain points, and access locations for instrumentation and engine controls.

The information and configuration of components shown in these drawings are of a general nature. Some component locations will vary depending on applications and installations.

Conventional Aftercooling

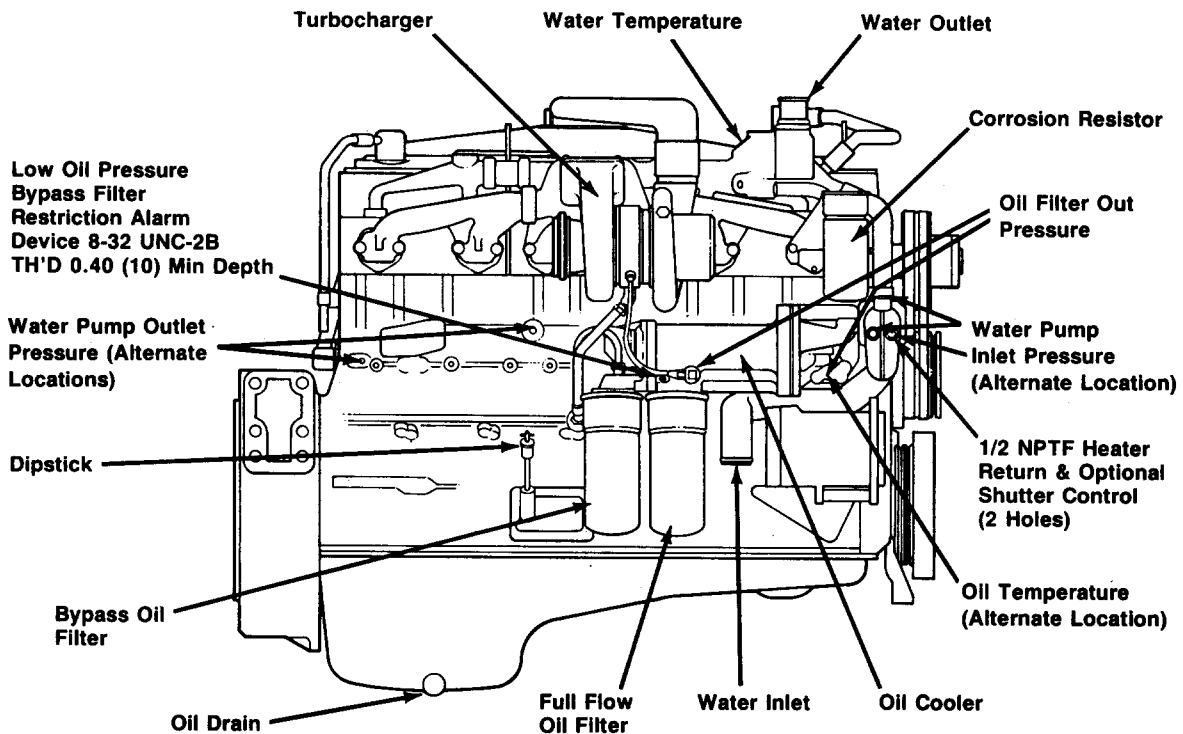
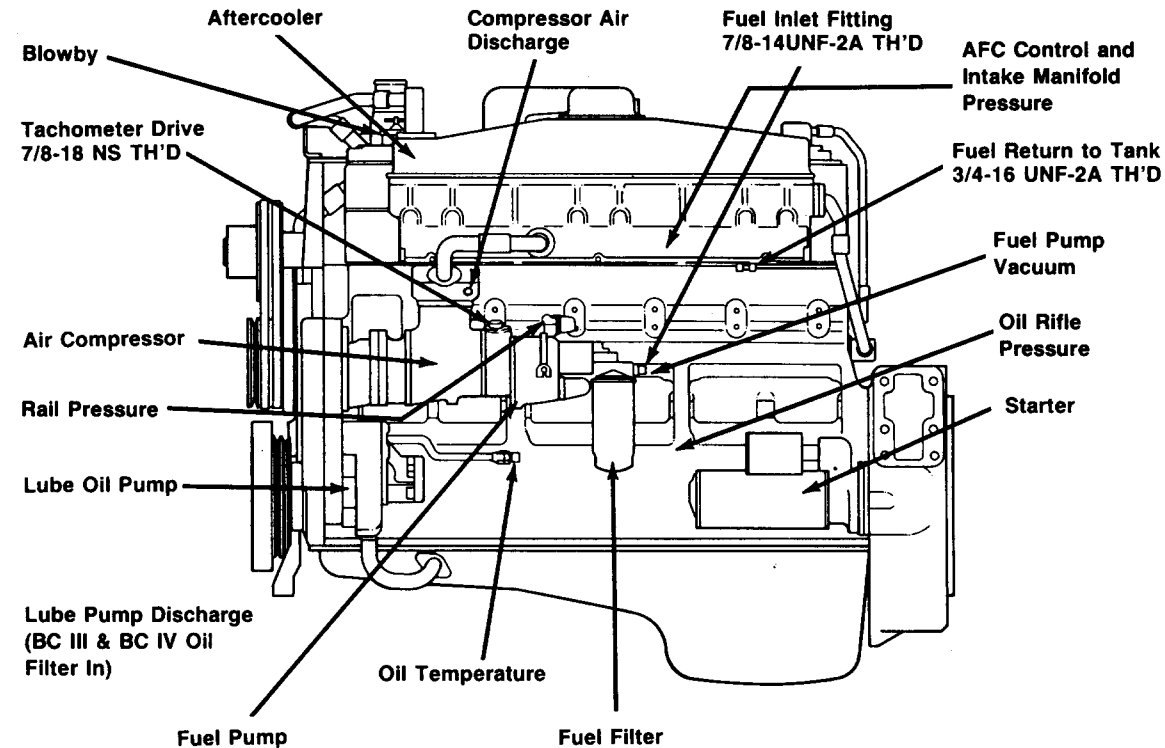

Optimized Aftercooling

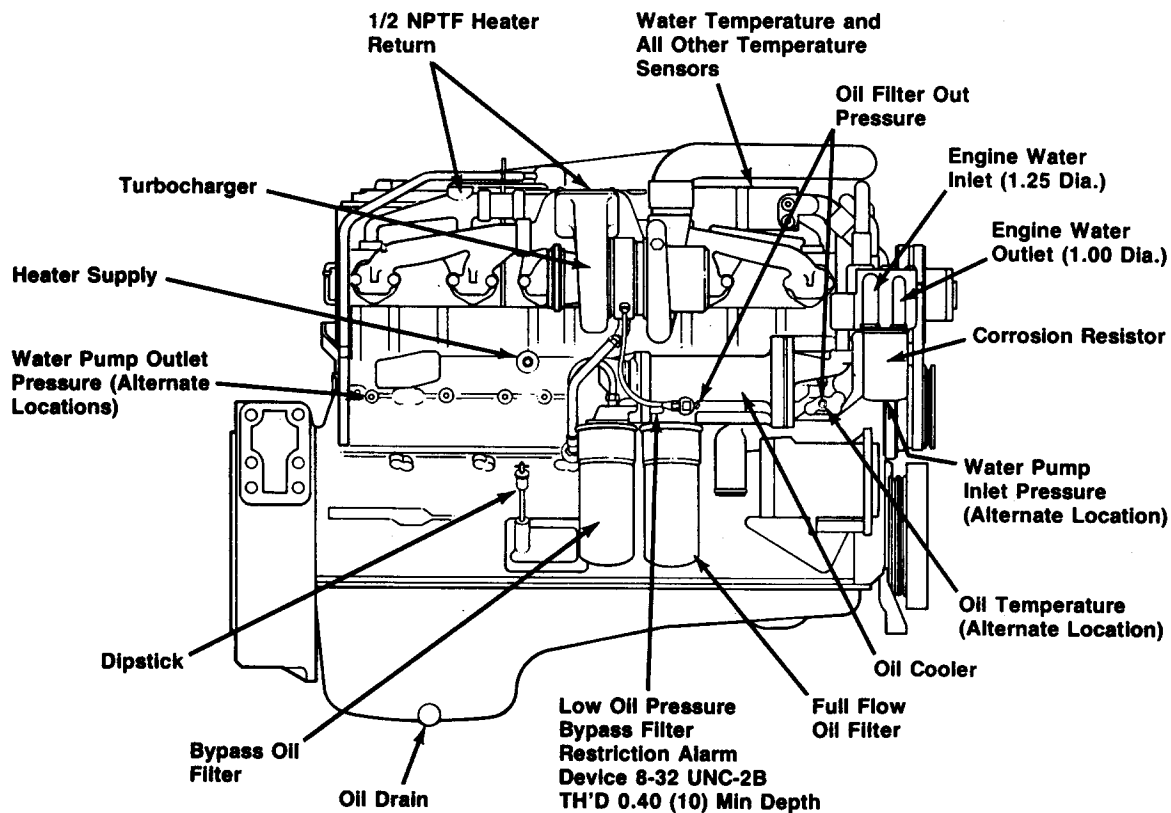
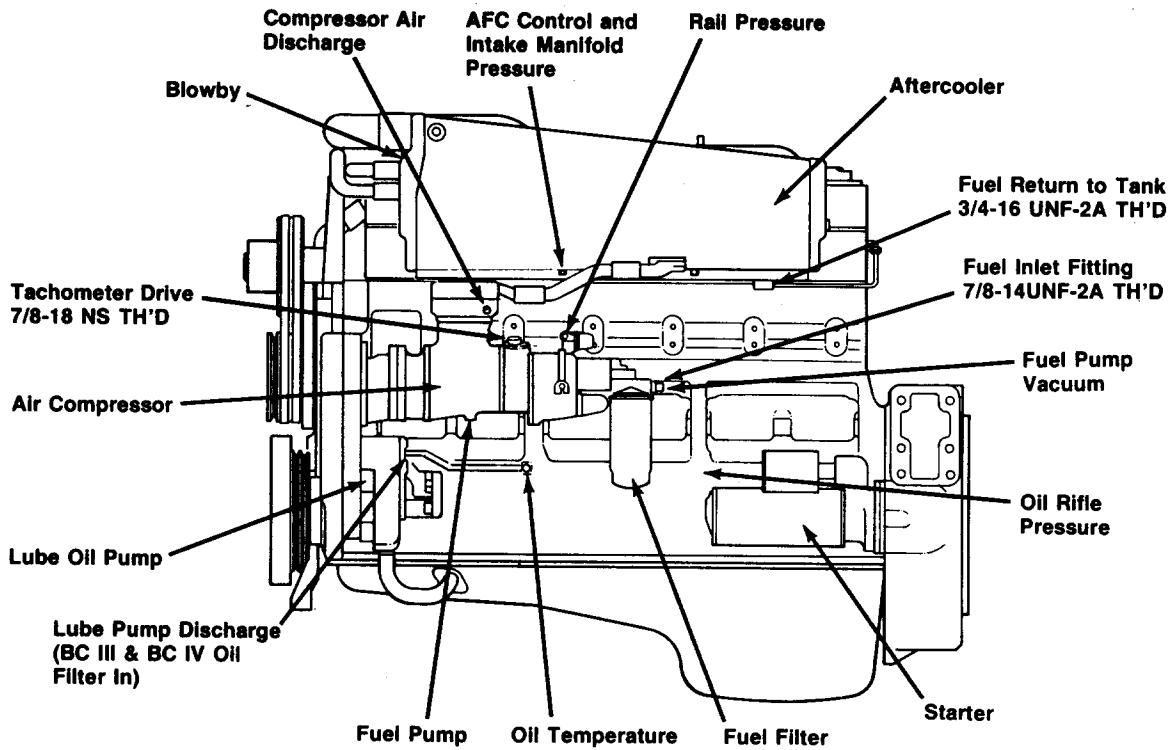

Section T - Troubleshooting

Procedures and Techniques

A thorough analysis of the customer's complaint is the key to successful troubleshooting. The more information known about a complaint, the faster and easier the problem can be solved.

The "Troubleshooting Symptoms Charts" beginning on page 3 are organized so that a problem can be located and corrected by doing the easiest and most logical things first. Complete all steps in the sequence shown from top to bottom.

It is **not** possible to include all the solutions to problems that can occur; however, these charts should stimulate a thought process that will lead to the cause and correction of the problem.

Follow these basic troubleshooting steps:

- Get all the facts concerning the complaint.
- Analyze the problem thoroughly.
- Relate the symptoms to the basic engine systems and components.
- Consider any recent maintenance or repair action that may relate to the problem.
- Double-check before beginning any disassembly.
- Solve the problem by using the logic charts and doing the easiest things first.
- Use Compuchek® where applicable to diagnose a problem.
- Determine the cause of the problem and make a thorough repair.
- After repairs have been made, operate the engine to make sure the cause of the problem has been corrected.