

# SHOP MANUAL

**KOMATSU**

# 4D105-3 S4D105-3 DIESEL ENGINE

ENGINE MODEL	APPLICABLE MACHINE MODEL
4D105-3C	D31A,P,S,Q-16
4D105-3D	GD22AC-1A
4D105-3G	GD28AC-1A
4D105-3L	EC50V,VS-1
4D105-3K	EC75Z,ZS-1
4D105-3H	EG45-1
4D105-3J	EG45S-1
4D105-3	CD40,40C-1
4D105-3	W40-1
4D105-3	BC100-1
S4D105-3B	D40A,P-1, D40F-1A
S4D105-3C	D45A,P-1
S4D105-3D	D45S-1
S4D105-3H	EG55-1
S4D105-3J	EG55S-1

# CONTENTS

	No. of page
01 GENERAL .....	01-001
11 STRUCTURE AND FUNCTION .....	11-001
12 TESTING AND ADJUSTING .....	12-001
13 DISASSEMBLY AND ASSEMBLY .....	13-001
14 MAINTENANCE STANDARD .....	14-001
15 REPAIR AND REPLACEMENT .....	15-001

---

# ENGINE

## 01 GENERAL

---

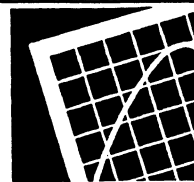

General view .....	01-002
Specifications .....	01-004
General assembly drawing .....	01-008
Performance curve .....	01-016
Weight table .....	01-027

# GENERAL VIEW

4D105-3 (For D31A, P, S, Q-16)

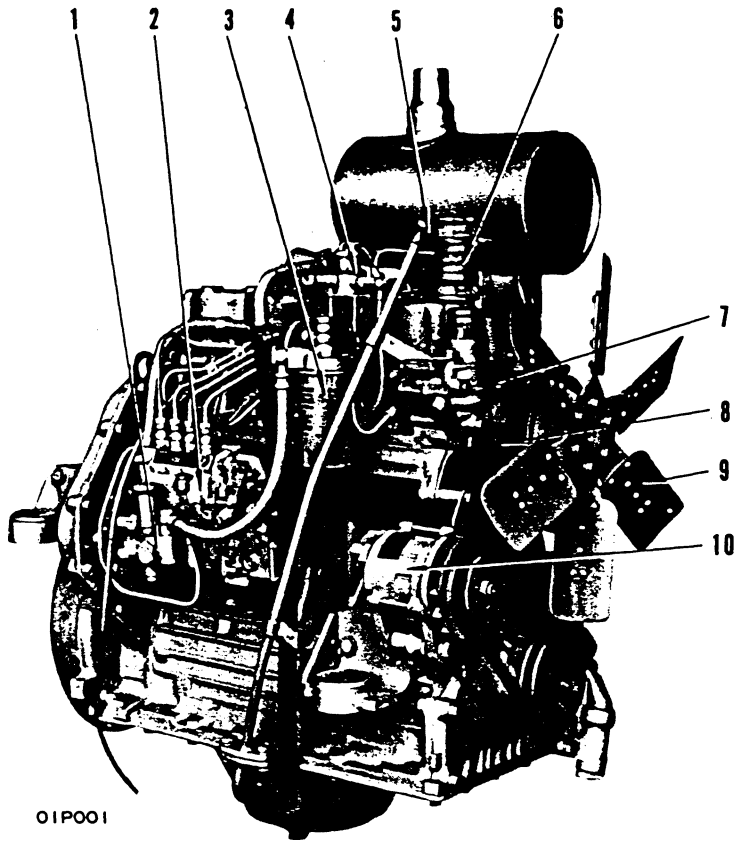

- 1. Feed pump
- 2. Fuel injection pump
- 3. Fuel filter
- 4. Magnetic valve
- 5. Dipstick
- 6. Oil filler
- 7. Thermostat housing
- 8. Water pump
- 9. Fan
- 10. Alternator

O1P001

- 11. Muffler
- 12. Oil filter
- 13. Starting motor
- 14. Oil pump cover

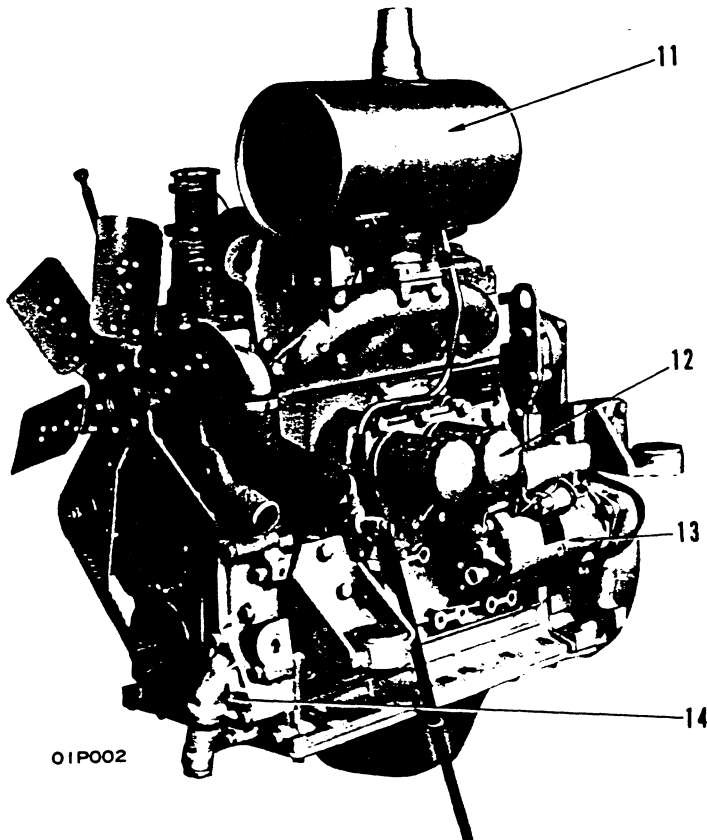

O1P002

S4D105-3 (For D40A, P-1)

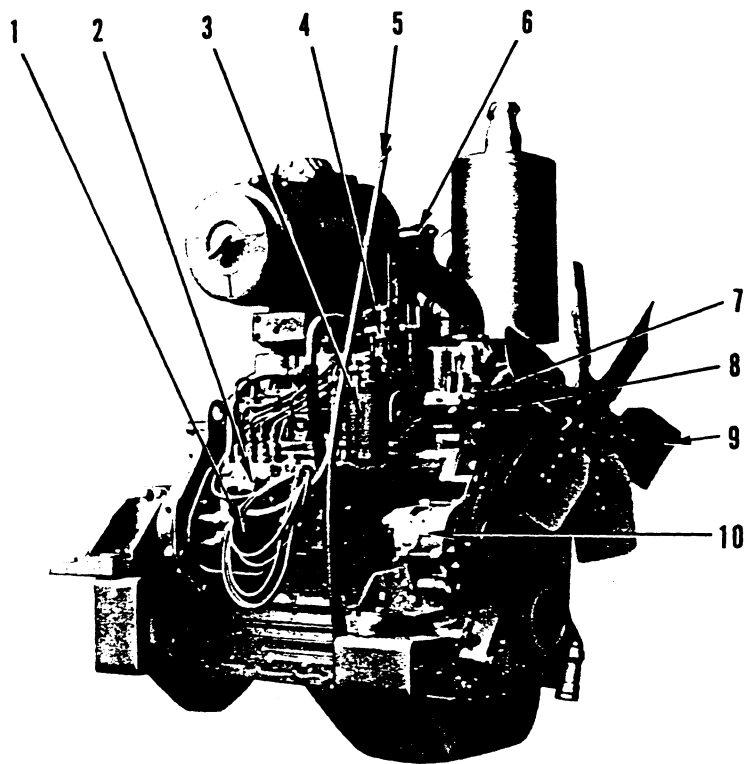

- 1. Feed pump
- 2. Injection pump
- 3. Fuel filter
- 4. Magnetic valve
- 5. Dipstick
- 6. Oil filler
- 7. Thermostat housing
- 8. Water pump
- 9. Fan
- 10. Alternator

- 11. Air cleaner
- 12. Muffler
- 13. Turbocharger
- 14. Oil filter
- 15. Starting motor
- 16. Oil pump cover

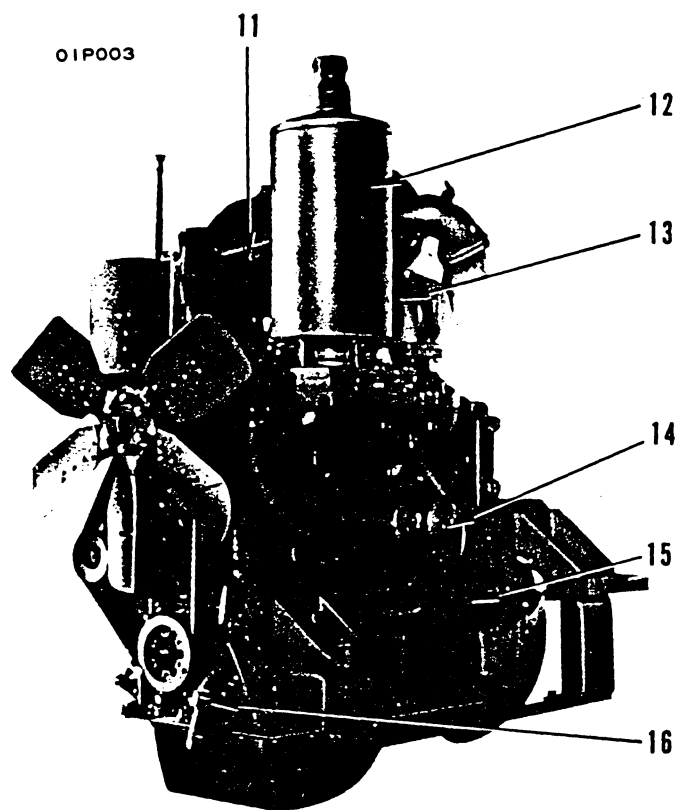

OIP004

# SPECIFICATIONS

Engine model		4D105-3C	4D105-3D	4D105-3G
Applicable machine		D31A,P,S,Q-16	GD22AC-1A	GD28AC-1A
No. of cylinders – Bore x Stroke (mm)		4 – 105 x 125		
Total piston displacement (cc)		4,330		
Firing order		1–2–4–3		
Dimensions	Overall length (Fan to flywheel housing) (mm)	955 (Fan to rear support)	925	968 (Fan to rear support)
	Overall width (mm)	- 614	670	770
	Overall height (Top of exhaust pipe to oil pan) (mm)	1,197 (Top of fan to oil pan)	1,197	1,197
Performance	Flywheel horsepower (HP/rpm)	63/2,350	65/2,300	75/2,400
	Maximum torque (kgm/rpm)	25/1,400	24/1,350	26.8/1,400
	High idling speed (rpm)	2,650 – 2,750	2,450 – 2,550	2,600 – 2,700
	Low idling speed (rpm)	700 – 750	700 – 750	700 – 750
	Min. fuel consumption ratio (g/HPH)	170 max.	170 max.	175 max.
Dry weight (kg)		500	500	500
Fuel		ASTM D975 No.1 and No.2		
Fuel injection pump		Bosch type PES-A		
Governor		Bosch RSV Centrifugal, all-speed type		
Oil capacity (ℓ)		13	13	13
Coolant capacity (ℓ)		22	27	27
Alternator		24V, 25A	24V, 25A	24V, 25A
Starting motor		24V, 5.2kw	24V, 5.2kw	24V, 5.2kw
Battery		12V 120Ah x 2	12V 110Ah x 2	12V 110Ah x 2
Turbocharger		–	–	–

4D105-3L	4D105-3K	4D105-3H	4D105-3J	4D105-3	4D105-3
EC50V,VS-1	EC75Z,ZS-1	EG45-1	EG45S-1	CD40, 40C-1	W40-1

4 – 105 x 125

4,330

1-2-4-3

971	971	935	948	955 (Fan to rear support)	935
715	715	765	765	614	762
1,640	1,640	1,209	933	1,077	1,160
52/2,000	65/2,400	49/1,500 (50Hz) 57/1,800 (60Hz)	49/1,500 (50Hz) 57/1,800 (60Hz)	63/2,300	68/2,500
22.5/1,400	24/1,600	—	—	25/1,400	25/1,600
2,150 – 2,250	2,600 – 2,700	1,560max. (50Hz) 1,872max. (60Hz)	1,560max. (50Hz) 1,872max. (60Hz)	2,650 – 2,750	2,700 – 2,800
700 – 750	700 – 750	—	—	700 – 750	700 – 750
185 (at rated output)	185 (at rated output)	185 (at rated output)	185 (at rated output)	170 max.	170
500	500	500	500	500	500

ASTM D975 No.1 and No.2

Bosch type PES-A

Bosch RSV Centrifugal, all-speed type

13	13	13	13	13	13
39	27	17	17	22	35
24V, 25A	24V, 25A	24V, 25A	24V, 25A	24V, 25A	24V, 25A
24V, 5.2kw	24V, 5.2kw	24V, 5.2kw	24V, 5.2kw	24V, 5.2kw	24V, 5.2kw
12V 110Ah x 2	12V 110Ah x 2	12V 110Ah x 2	12V 110Ah x 2	12V 110Ah x 2	12V 110Ah x 2
—	—	—	—	—	—

## GENERAL

## SPECIFICATIONS

Engine model		S4D105-3B	S4D105-3C	S4D105-3D
Applicable machine		D40A,P-1 D40F-1A	D45A,P-1	D45S-1
No. of cylinders – Bore x Stroke (mm)		4 – 105 x 125		
Total piston displacement (cc)		4,330		
Firing order		1–2–4–3		
Dimensions	Overall length (Fan to flywheel housing) (mm)	986	986	986
	Overall width (mm)	776	776	726
	Overall height (Muffler to oil pan) (mm)	1,375	1,375	1,375
Performance	Flywheel horsepower (HP/rpm)	80/2,400	90/2,400	90/2,400
	Maximum torque (kgm/rpm)	32/1,200	32/1,400	32/1,400
	High idling speed (rpm)	2,600 – 2,700	2,600 – 2,700	2,600 – 2,700
	Low idling speed (rpm)	725 – 775	730 – 780	730 – 780
	Min. fuel consumption ratio (g/HPH)	165	165	165
Dry weight (kg)		540	540	540
Fuel		ASTM D975 No.1 and No.2		
Fuel injection pump		Bosch type PES-A		
Governor		Bosch RSV Centrifugal, all-speed type		
Oil capacity (ℓ)		18	18	18
Coolant capacity (ℓ)		30	40	40
Alternator		24V, 25A	24V, 25A	12V, 25A
Starting motor		24V, 5.2kw	24V, 5.2kw	24V, 5.2kw
Battery		12V 120Ah x 2	12V 120Ah x 2	12V 120Ah x 2
Turbocharger		T04B	T04B	T04B



S4D105-3H	S4D105-3J	
EG55-1	EG55S-1	
<p>4 – 105 x 125 4,330 1-2-4-3</p>		
994 765 1,038	959 765 962	
<p>58/1,500 (50Hz) 70/1,800 (60Hz)</p> <p>—</p> <p>1,560 max. (50Hz) 1,872 max. (60Hz)</p> <p>—</p> <p>185 (at rated output)</p>	<p>58/1,500 (50Hz) 70/1,800 (60Hz)</p> <p>—</p> <p>1,560 max. (50Hz) 1,872 max. (60Hz)</p> <p>—</p> <p>185 (at rated output)</p>	
530	530	
<p>ASTM D975 No.1 and No.2</p> <p>Bosch type PES-A</p> <p>Bosch RSV Centrifugal, all-speed type</p>		
13	13	
17	17	
<p>24V, 25A</p> <p>24V, 5.2kw</p> <p>12V 120Ah x 2</p>	<p>24V, 25A</p> <p>24V, 5.2kw</p> <p>12V 120Ah x 2</p>	
T04B	T04B	

# GENERAL ASSEMBLY DRAWING

4D105-3 LEFT SIDE VIEW (For D31A, P, S, Q-16)

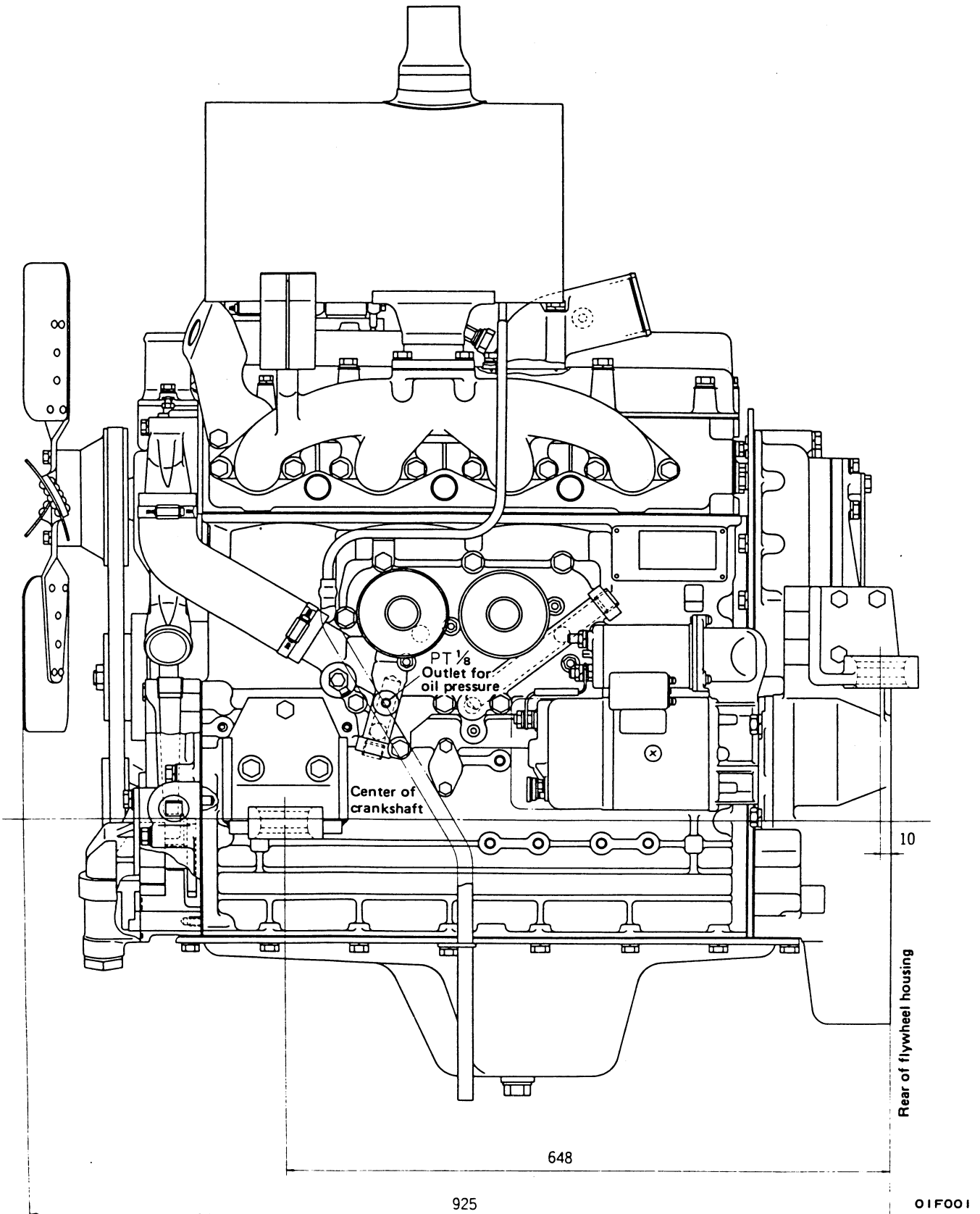

4D105-3 RIGHT SIDE VIEW (For D31A, P, S, Q-16)

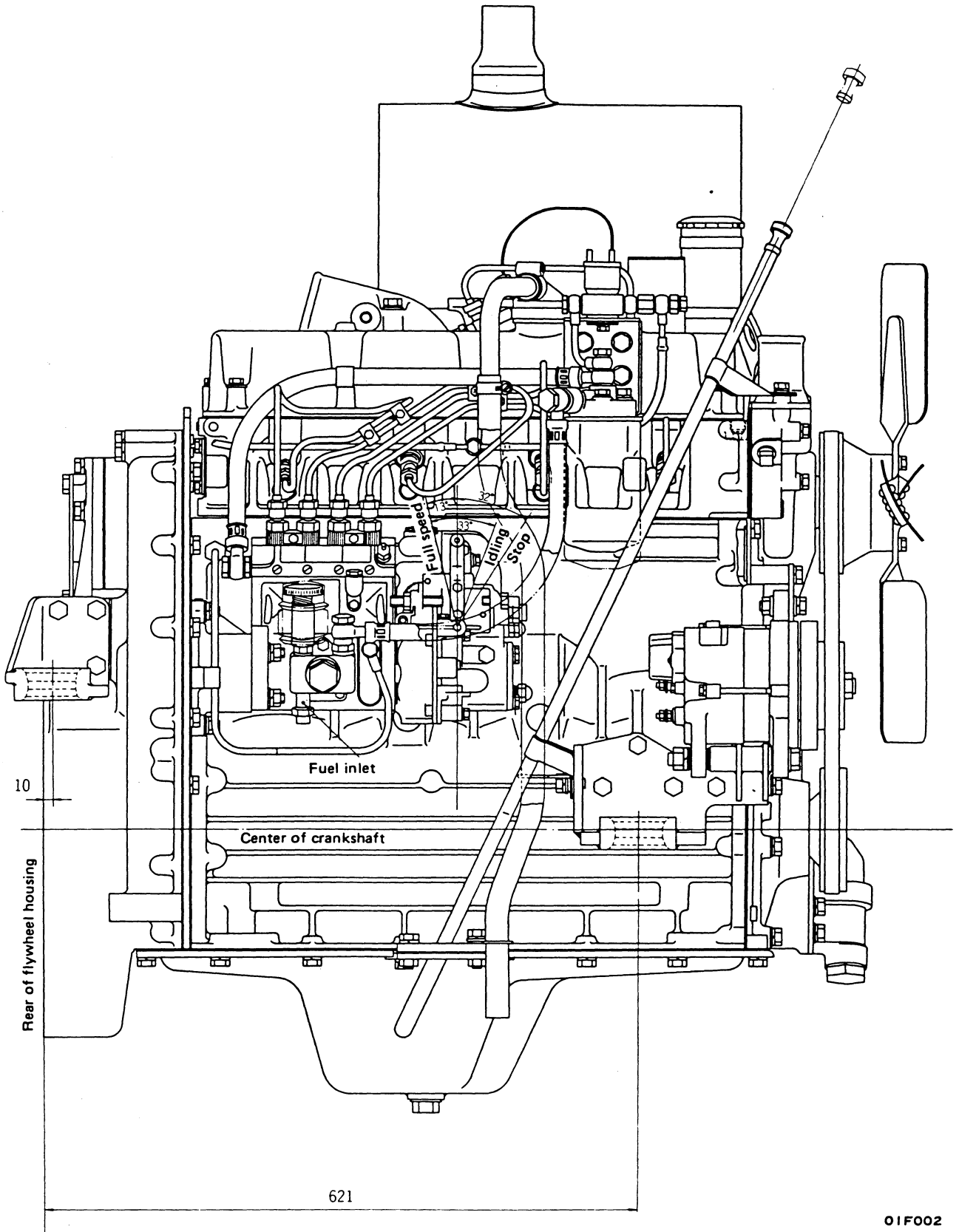

01F002

4D105-3 FRONT VIEW (For D31A, P, S, Q-16)

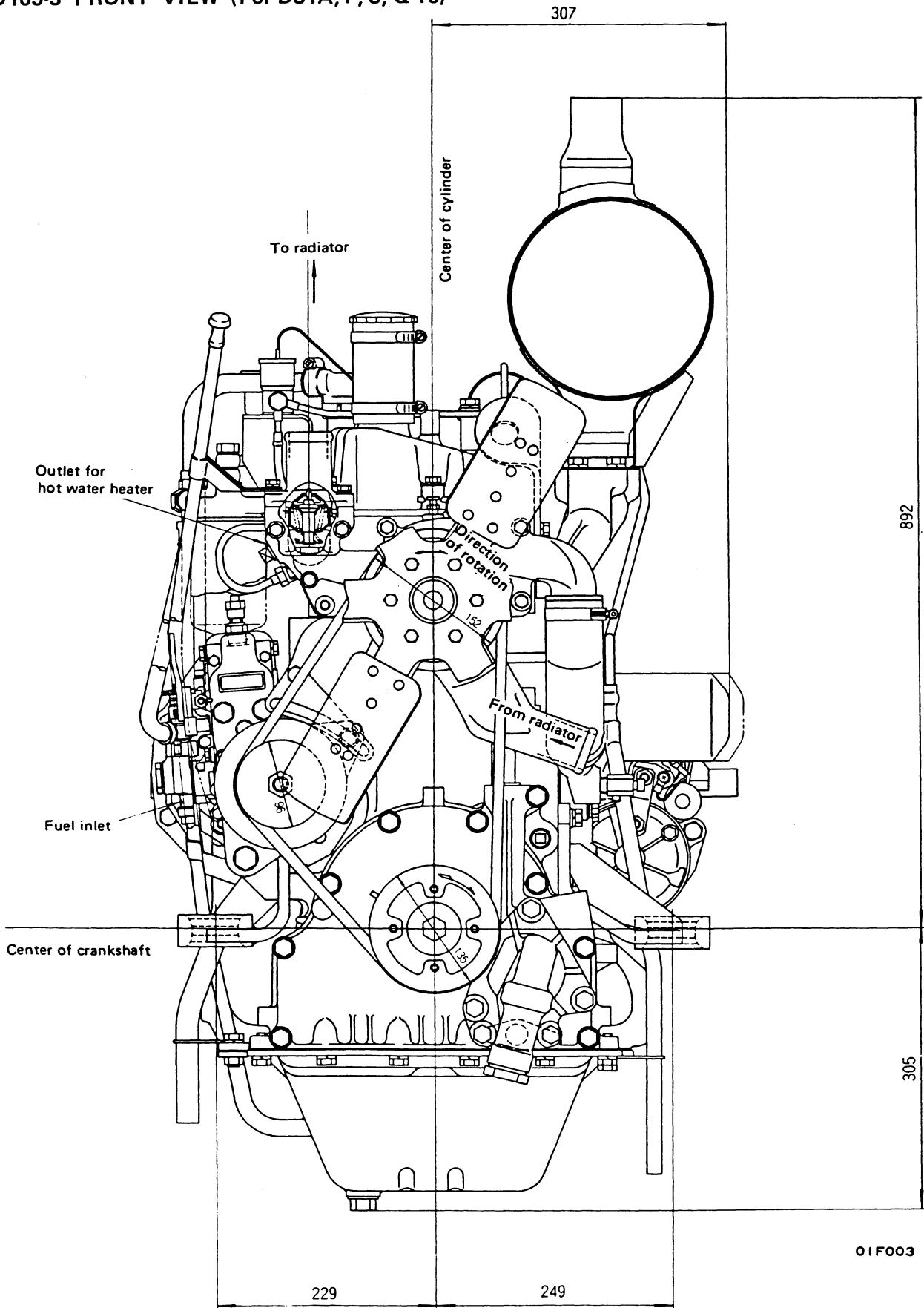

4D105-3 REAR VIEW (For D31A, P, S, Q-16)

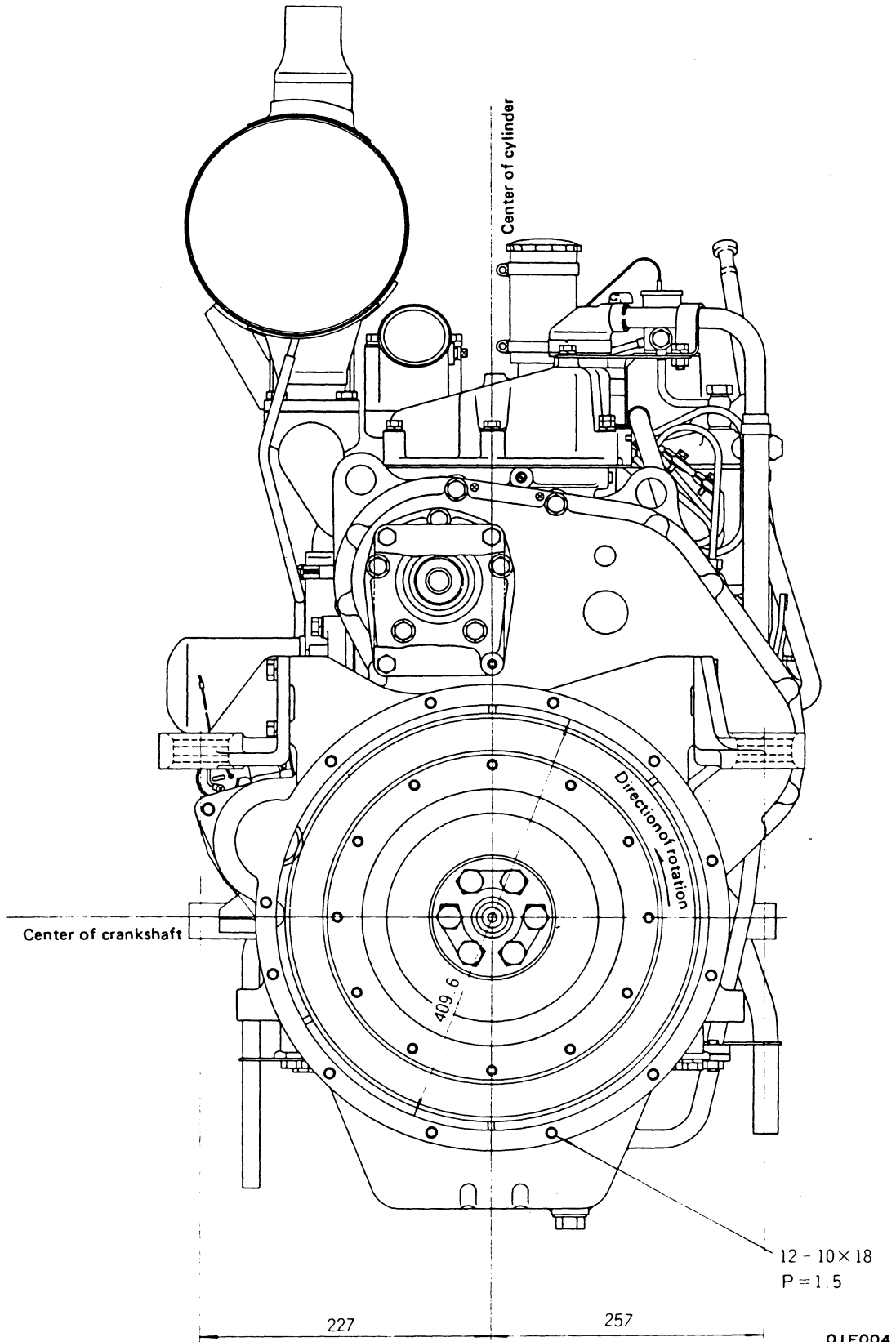

S4D105-3 LEFT SIDE VIEW (For D45A, P-1)

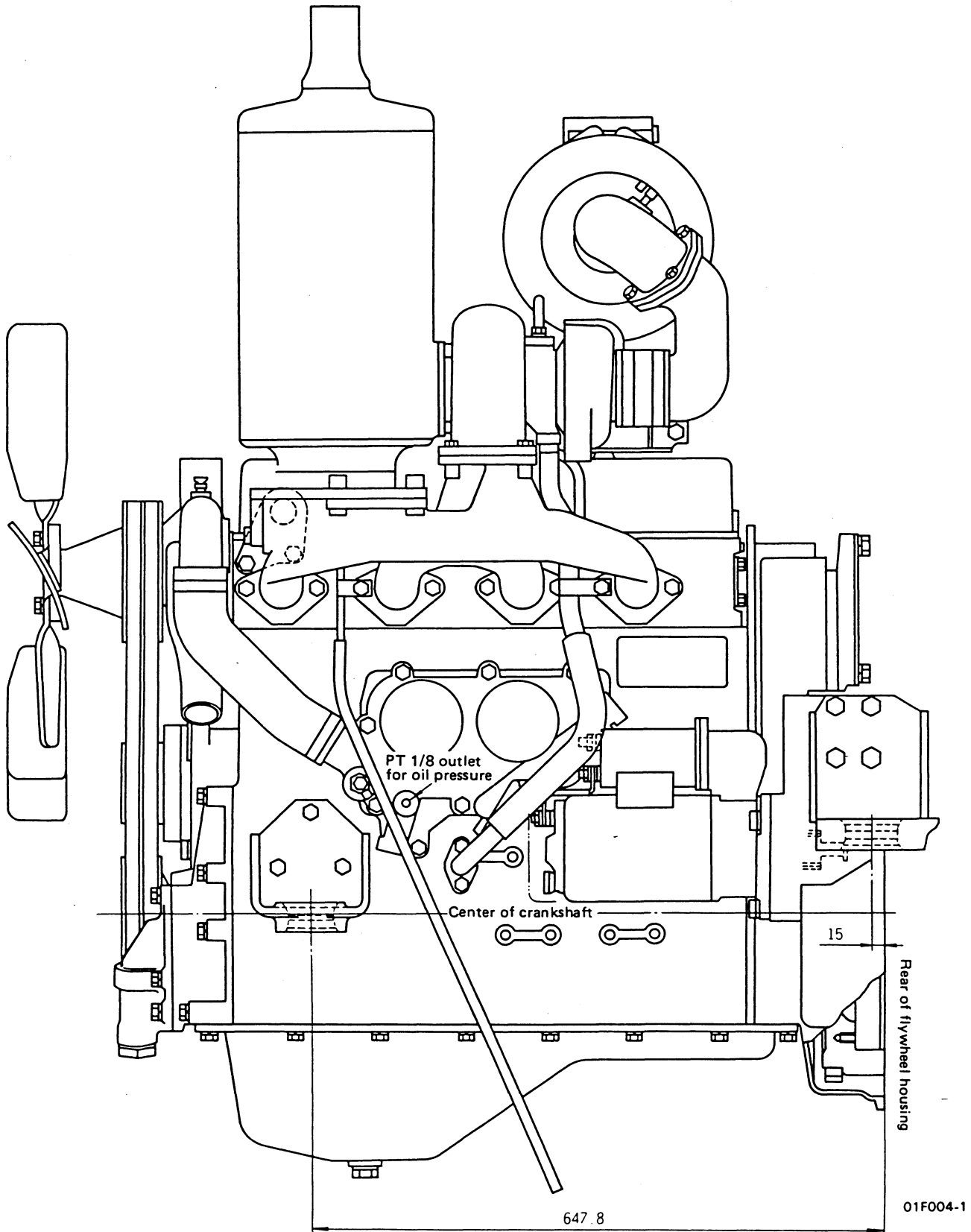

S4D105-3 RIGHT SIDE VIEW (For D45A, P-1)

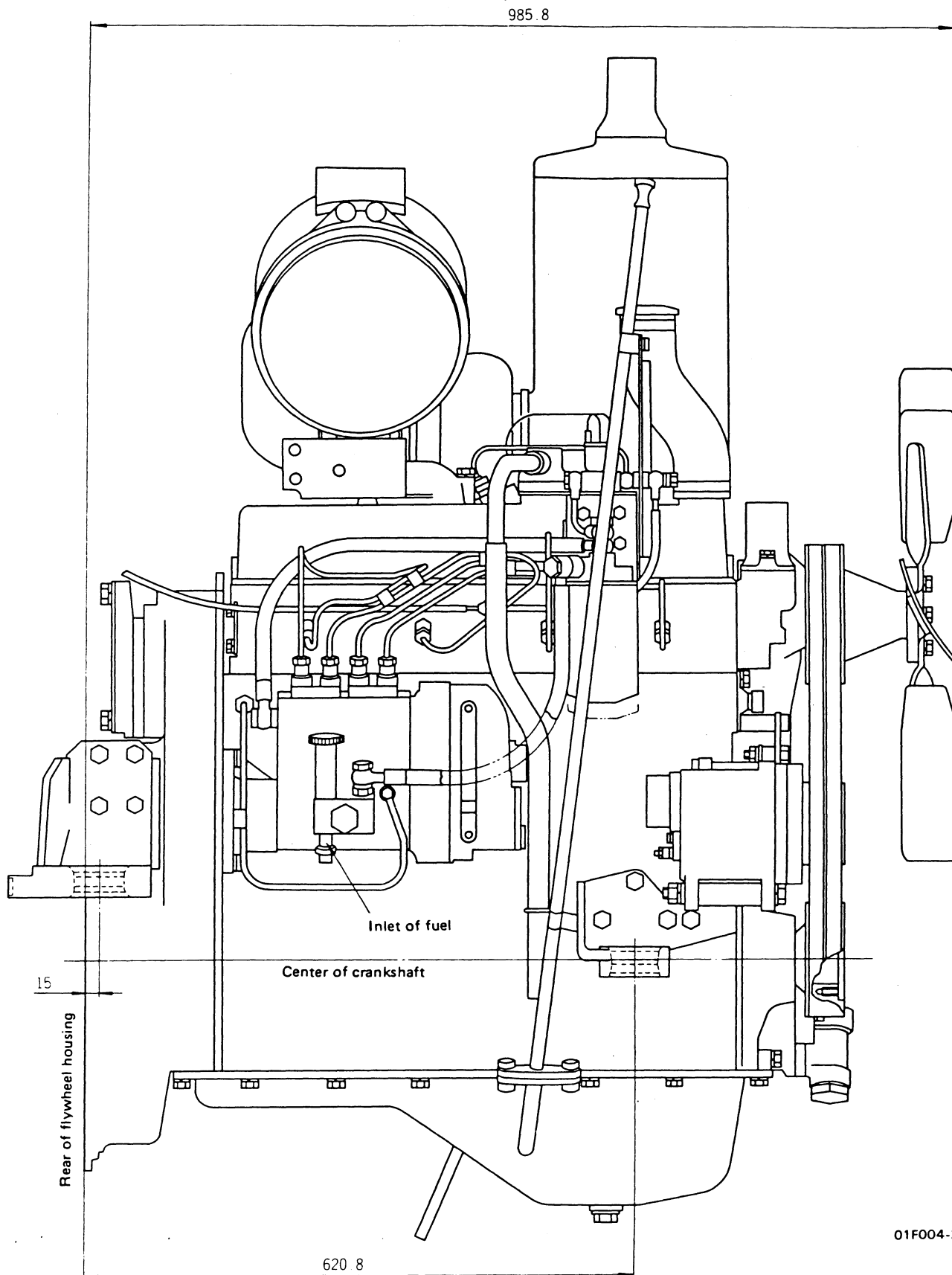

01F004-2

S4D105-3 FRONT VIEW (For D45A, P-1)

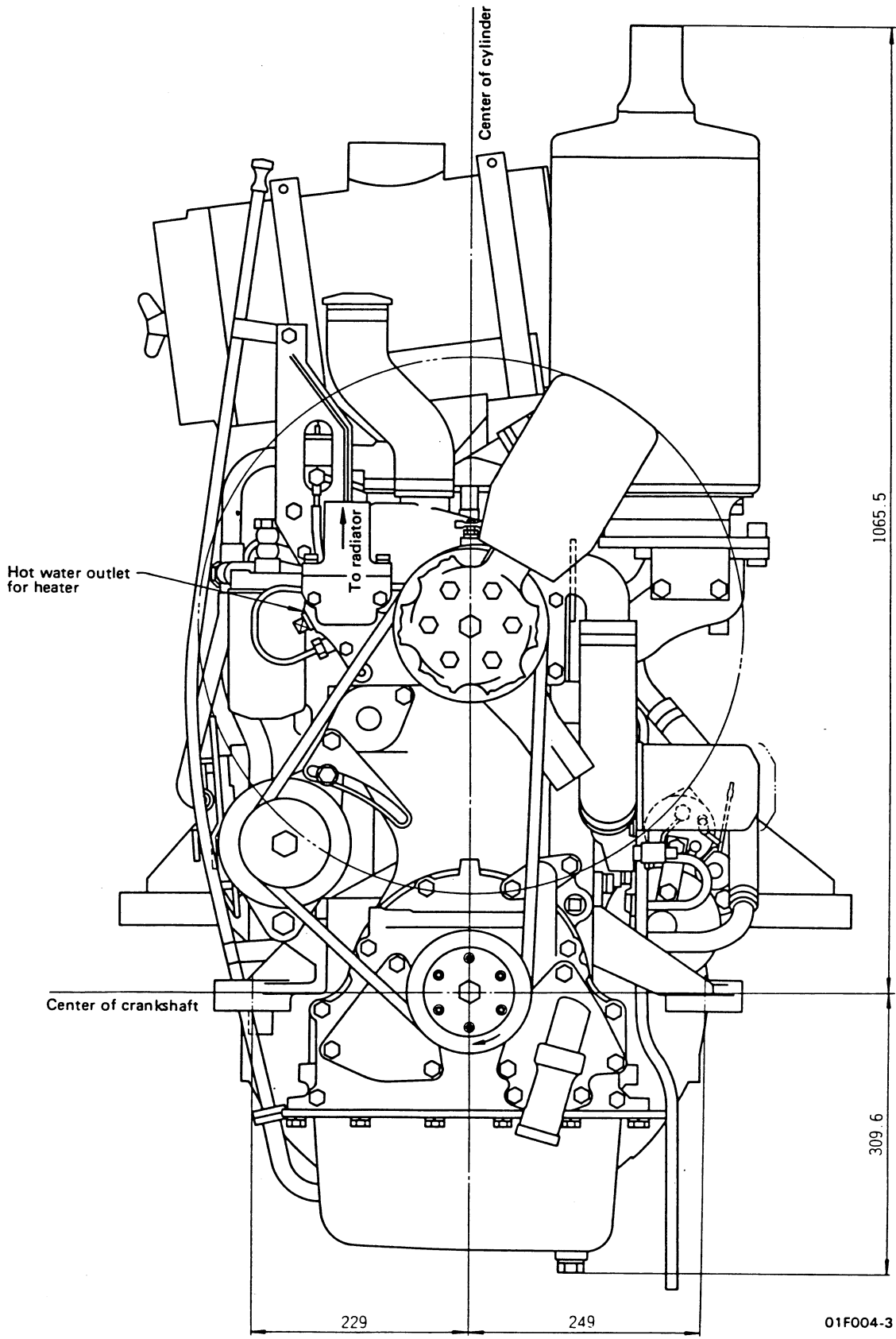

01F004-3



S4D105-3 REAR VIEW (For D45A, P-1)

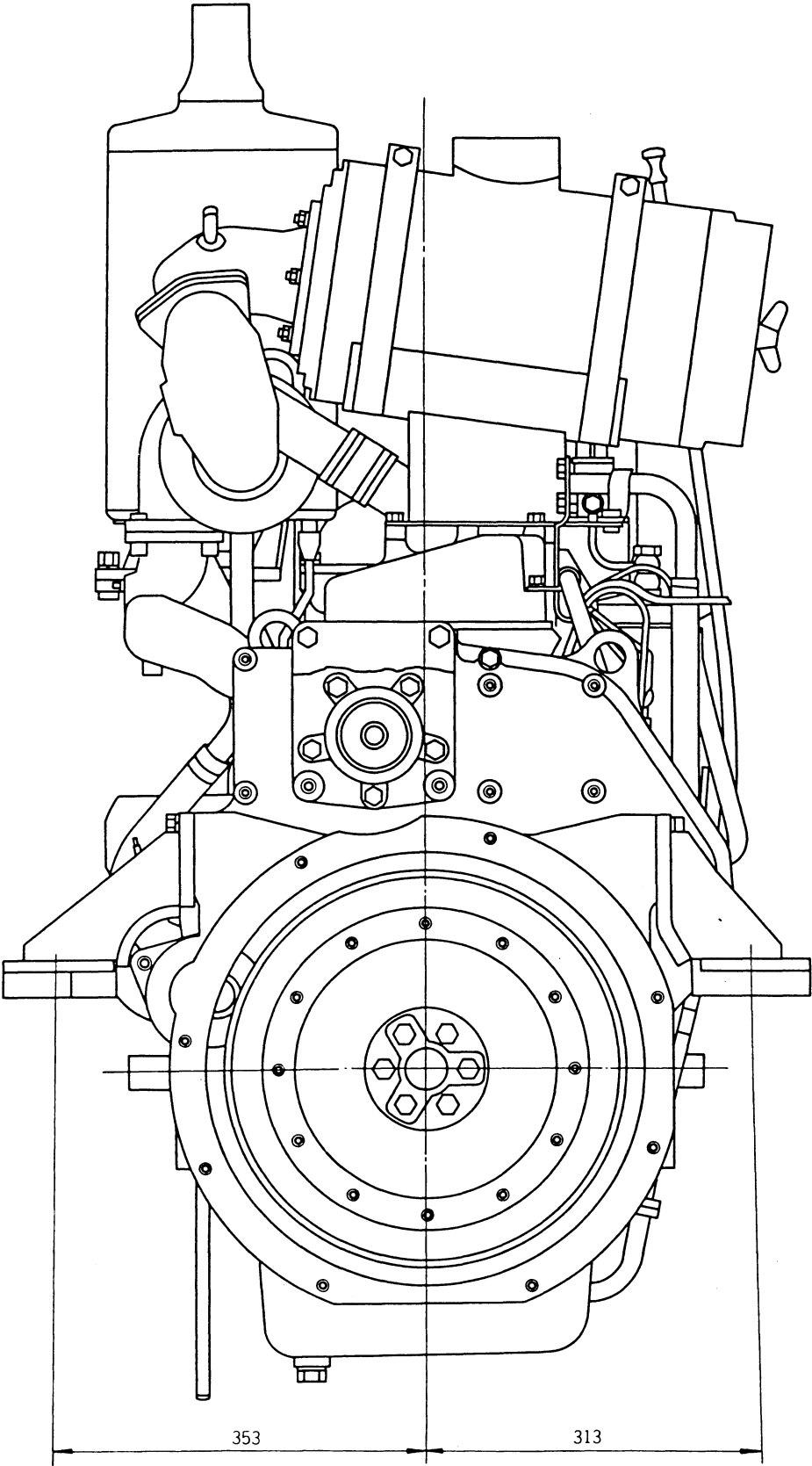

01F004-4

# PERFORMANCE CURVE

4D105-3C for D31A·P·S·Q-16

4D105-3R for CD40·40C-1

Flywheel horsepower: 63HP/2,350 rpm  
 Max. torque: 25 kgm/1,400 rpm  
 Min. fuel consumption ratio: 170 g/HP.h

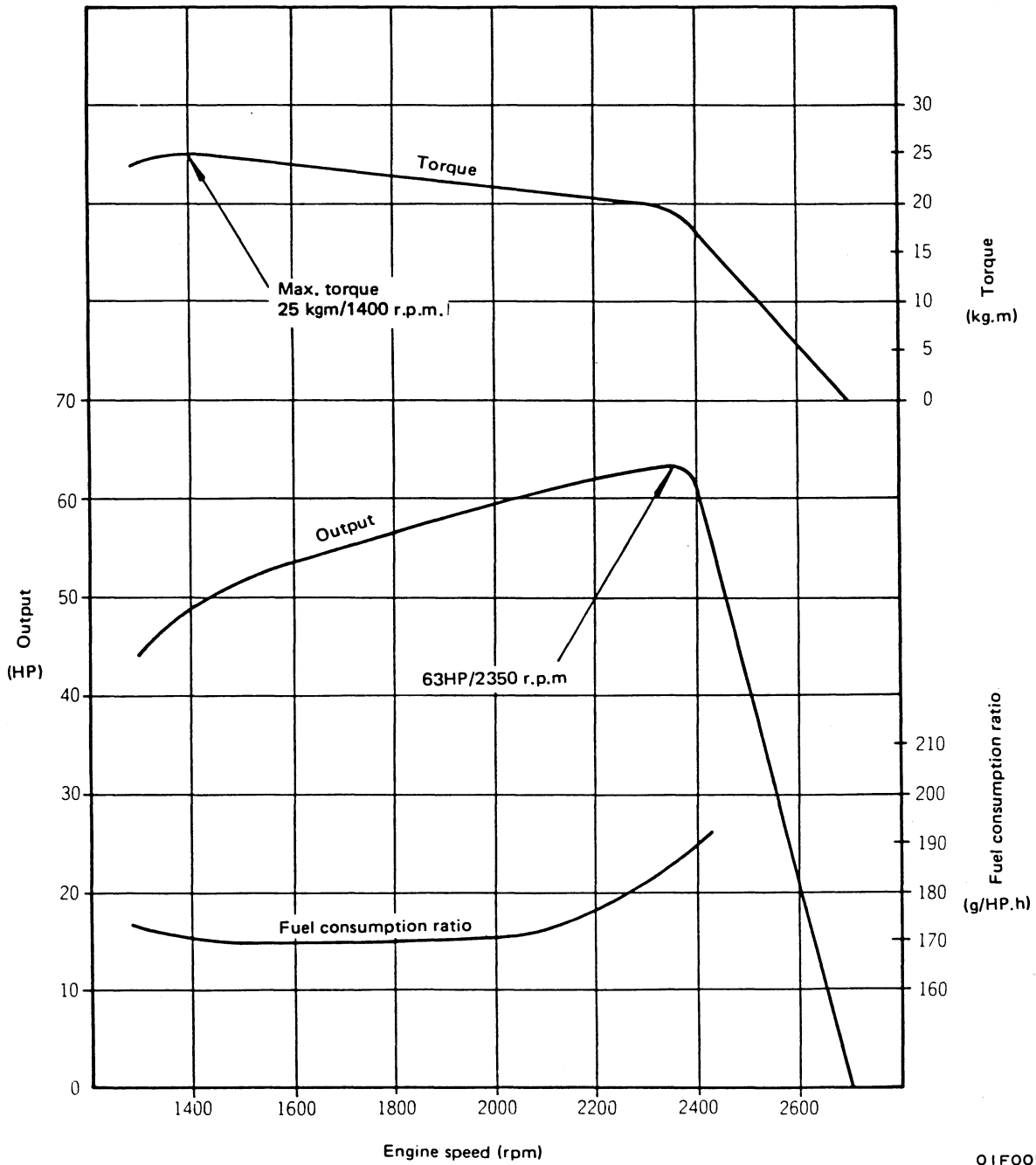

01F005

4D105-3D for GD22AC-1

Flywheel horsepower: 65HP/2,300 rpm  
Max. torque: 24 kgm/1,350 rpm  
Min. fuel consumption ratio: 170 g/HP.h

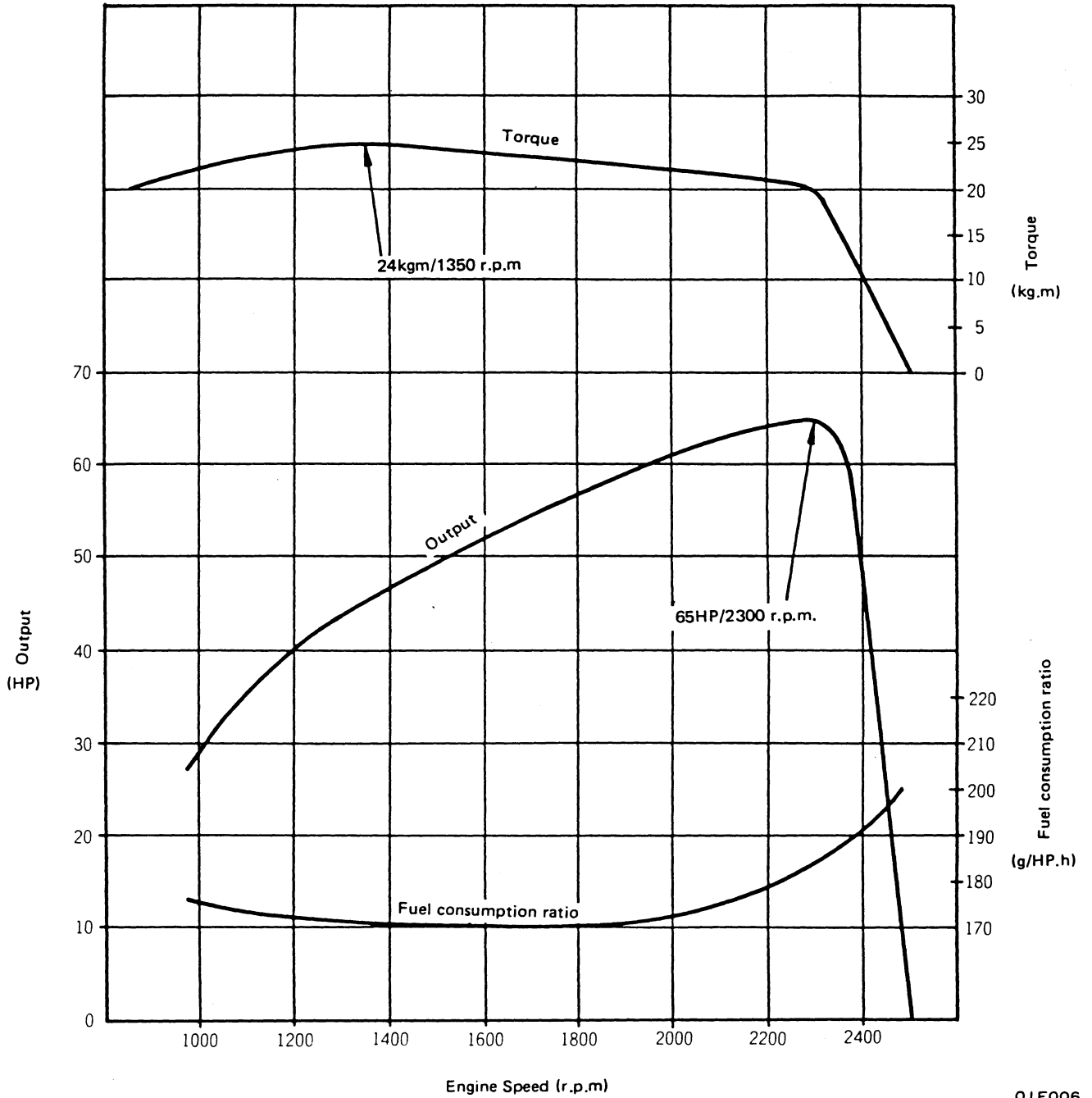

01F006

4D105-3G for GD28AC-1

Flywheel horsepower: 75HP/2,400 rpm  
Max. torque: 26.8 kg.m/1,400 rpm  
Min. fuel consumption ratio: 175 g/HP.h

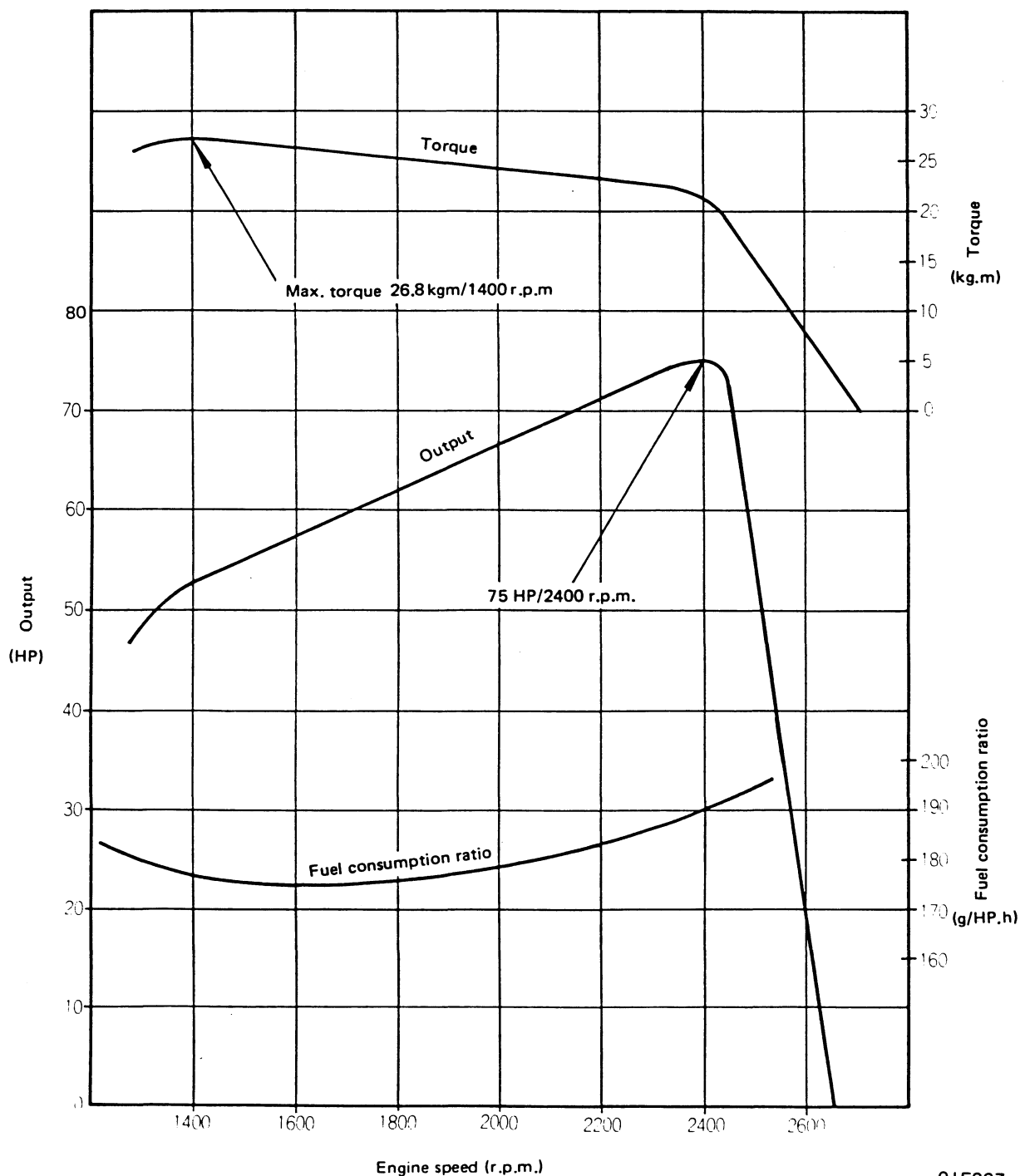

01F007