

Shop Manual

930E-2

DUMP TRUCK

SERIAL NUMBERS **A30296, A30297, A30300**

KOMATSU

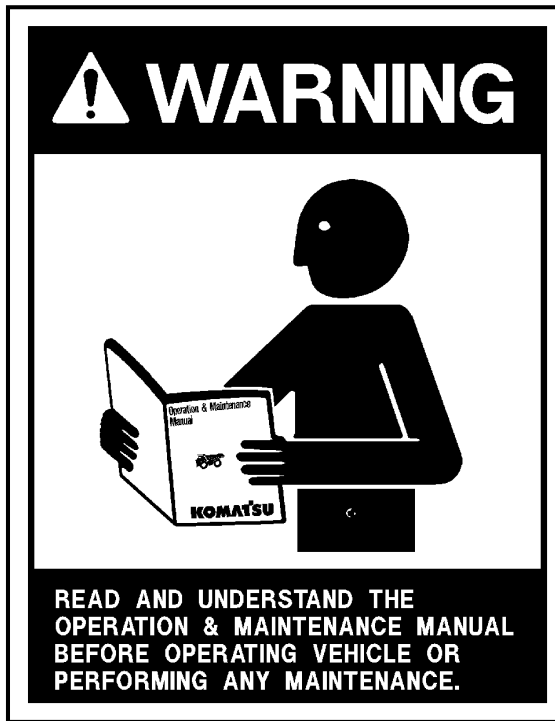

Unsafe use of this machine may cause serious injury or death. Operators and maintenance personnel must read and understand this manual before operating or maintaining this machine.

This manual should be kept in or near the machine for reference, and periodically reviewed by all personnel who will come into contact with it.

This material is proprietary to Komatsu America Corp (KAC), and is not to be reproduced, used, or disclosed except in accordance with written authorization from KAC.

It is the policy of the Company to improve products whenever it is possible and practical to do so. The Company reserves the right to make changes or add improvements at any time without incurring any obligation to install such changes on products sold previously.

Because of continuous research and development, periodic revisions may be made to this publication. Customers should contact their local Komatsu distributor for information on the latest revision.

CALIFORNIA

Proposition 65 Warning

Diesel engine exhaust, some of its constituents, and certain vehicle components contain or emit chemicals known to the State of California to cause cancer, birth defects or other reproductive harm.

CALIFORNIA

Proposition 65 Warning

Battery posts, terminals and related accessories contain lead and lead compounds, chemicals known to the State of California to cause cancer and birth defects or other reproductive harm. Wash hands after handling.

NOTES

FOREWORD

This Shop Manual is written for use by the service technician and is designed to help the technician become fully knowledgeable of the truck and all its systems in order to keep it running and in production. All maintenance personnel should read and understand the materials in this manual before performing maintenance and/or operational checks on the truck. All safety notices, warnings and cautions should be understood and followed when accomplishing repairs on the truck.

The first section covers component descriptions, truck specifications and safe work practices, as well as other general information. The major portion of the manual pertains to disassembly, service and reassembly. Each major serviceable area is dealt with individually. For example: The disassembly, service and reassembly of the radiator group is discussed as a unit. The same is true of the engine and engine accessories, and so on through the entire mechanical detail of the truck. Disassembly should be carried only as far as necessary to accomplish needed repairs.

The illustrations used in this manual are, at times, typical of the component shown and may not necessarily depict a specific model.

This manual shows dimensioning of U.S. standard and metric (SI) units throughout and all references to "Right", "Left", "Front", or "Rear" are made with respect to the operator's normal seated position, unless specifically stated otherwise.

Standard torque requirements are shown in torque charts in the general information section and individual torques are provided in the text in bold face type, such as **100 ft.lbs. (135 N.m)** torque. All torque specifications have $\pm 10\%$ tolerance unless otherwise specified.

A Product Identification plate is normally located on the truck frame in front of the right side front wheel and designates the Truck Model Number, Product Identification Number (vehicle serial number), and Maximum G.V.W. (Gross Vehicle Weight) rating.

The KOMATSU Truck Model designation consists of three numbers and one letter (i.e. 930E). The three numbers represent the basic truck model. The letter "M" designates a Mechanical drive and the letter "E" designates an Electrical propulsion system.

The Product Identification Number (vehicle serial number) contains information which will identify the original manufacturing bill of material for this unit. This complete number will be necessary for proper ordering of many service parts and/or warranty consideration.

The Gross Vehicle Weight (GVW) is what determines the load on the drive train, frame, tires, and other components. The vehicle design and application guidelines are sensitive to the **total maximum Gross Vehicle Weight (GVW)** and this **means the total weight**: the Empty Vehicle Weight + the fuel & lubricants + the payload.

To determine allowable payload: Service all lubricants for proper level and fill fuel tank of empty truck (which includes all accessories, body liners, tailgates, etc.) and then weigh truck. Record this value and subtract from the GVW rating. The result is the allowable payload.

NOTE: Accumulations of mud, frozen material, etc. become a part of the GVW and reduces allowable payload. To maximize payload and to keep from exceeding the GVW rating, these accumulations should be removed as often as practical.

Exceeding the allowable payload will reduce expected life of truck components.



This “ALERT” symbol is used with the signal words, “DANGER”, “WARNING”, and “CAUTION” in this manual to alert the reader to hazards arising from improper operating and maintenance practices.



“DANGER” identifies a specific potential hazard WHICH WILL RESULT IN EITHER INJURY OR DEATH if proper precautions are not taken.



“WARNING” identifies a specific potential hazard WHICH MAY RESULT IN EITHER INJURY OR DEATH if proper precautions are not taken.



“CAUTION” is used for general reminders of proper safety practices OR to direct the reader’s attention to avoid unsafe or improper practices which may result in damage to the

TABLE OF CONTENTS

SUBJECT	SECTION
GENERAL INFORMATION	A
STRUCTURES	B
ENGINE SYSTEMS.....	C
ELECTRIC SYSTEM (24 VDC. NON-PROPULSION)	D
ELECTRIC PROPULSION AND CONTROL.....	E
DRIVE AXLE, SPINDLES AND WHEELS.....	G
HYDRAIR® II SUSPENSIONS	H
BRAKE CIRCUIT.....	J
HYDRAULIC SYSTEM	L
OPTIONS AND SPECIAL TOOLS.....	M
OPERATOR'S CAB	N
LUBRICATION AND SERVICE	P
ALPHABETICAL INDEX	Q
SYSTEM SCHEMATICS	R

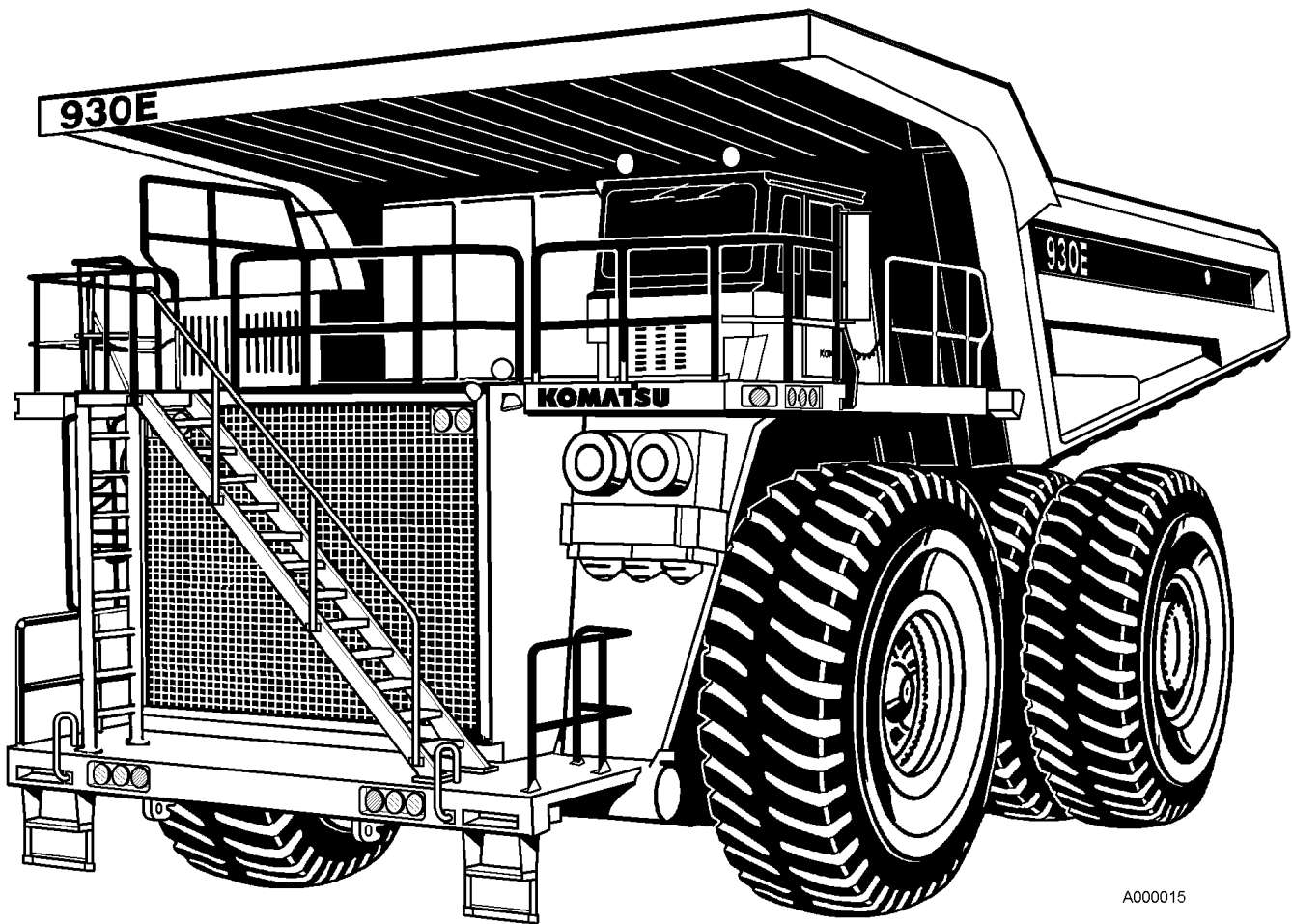

A000015

KOMATSU MODEL 930E DUMP TRUCK

SECTION A
GENERAL INFORMATION

INDEX

TRUCK COMPONENT DESCRIPTION & SPECIFICATIONS	A2-1
GENERAL SAFETY AND TRUCK OPERATION	A3-1
WARNINGS AND CAUTIONS.....	A4-1
CHARTS AND TABLES.....	A5-1
STORAGE PROCEDURES	A7-1

NOTES

MAJOR COMPONENT DESCRIPTION

Truck And Engine

The 930E Dump Truck is an off-highway, rear dump truck with AC Electric Drive. The gross vehicle weight is 1,100,000 lbs. (498 960 kg). The engine is a Komatsu SSDA16V160 rated @ 2700 HP (2014 kW).

Alternator (GE-GTA42)

The diesel engine drives an in-line alternator at engine speed. The alternator produces AC current which is rectified to DC within the main control cabinet. The rectified DC power is converted back to AC by groups of devices called "inverters", also within the main control cabinet. Each inverter consists of six "phase modules" under the control of a "gate drive unit" (GDU). The GDU controls the operation of each phase module.

Each phase module contains an air-cooled solid-state switch referred to as a "gate turn-off thyristor" (GTO). The GTO cycles on and off at varying frequencies to create an AC power signal from the DC supply.

The AC power signal produced by each inverter is a variable-voltage, variable-frequency signal (VVVF). Frequency and voltage are changed to suit the operating conditions.

AC Induction Traction Motorized Wheels

The alternator output supplies electrical energy to the two wheel motors attached to the rear axle housing. The motorized wheels use three-phase AC induction motors with full-wave AC power.

The two wheel motors convert electrical energy back to mechanical energy through built-in gear trains within the wheel motor assembly. The direction of the wheel motors is controlled by a forward or reverse hand selector switch located on the center console.

Blower

Both the inverters and the wheel motors produce heat while in operation and must be cooled. Cooling air is provided by a dual impeller in-line blower mounted on the alternator.

Suspension

HYDRAIR®II suspension cylinders located at each wheel provide a smooth and comfortable ride for the operator and dampens shock loads to the chassis during loading and operation.

Operator's Cab

The operator cab has been engineered for operator comfort and to allow for efficient and safe operation of the truck. The cab provides wide visibility, with an integral 4-post ROPS/FOPS structure, and an advanced analog operator environment. It includes a tinted safety-glass windshield and power-operated side windows, a deluxe interior with a fully adjustable seat with lumbar support, a fully adjustable/tilt steering wheel, controls mounted within easy reach of the operator, and an analog instrument panel which provides the operator with all instruments and gauges which are necessary to control and/or monitor the truck's operating systems.

Power Steering

The truck is equipped with a full time power steering system which provides positive steering control with minimum operator effort. The system includes nitrogen-charged accumulators which automatically provide emergency power if the steering hydraulic pressure is reduced below an established minimum.

Dynamic Retarding

The dynamic retarding is used to slow the truck during normal operation or control speed coming down a grade. The dynamic retarding ability of the electric system is controlled by the operator through the activation of the retarder pedal (or by operating a lever on the steering wheel) in the operators cab and by setting the RSC (Retarder Speed Control). Dynamic Retarding is automatically activated, if the truck speed goes to a preset overspeed setting.

Brake System

Service brakes at each wheel are oil-cooled multiple disc brakes applied by an all-hydraulic actuation system. Depressing the brake pedal actuates both front and rear brakes, after first applying the retarder. All wheel brakes will be applied automatically, if system pressure decreases below a preset minimum.

The parking brake is a dry disc type, mounted inboard on each rear wheel motor, and is spring-applied and hydraulically-released with wheel speed application protection (will not apply with truck moving).

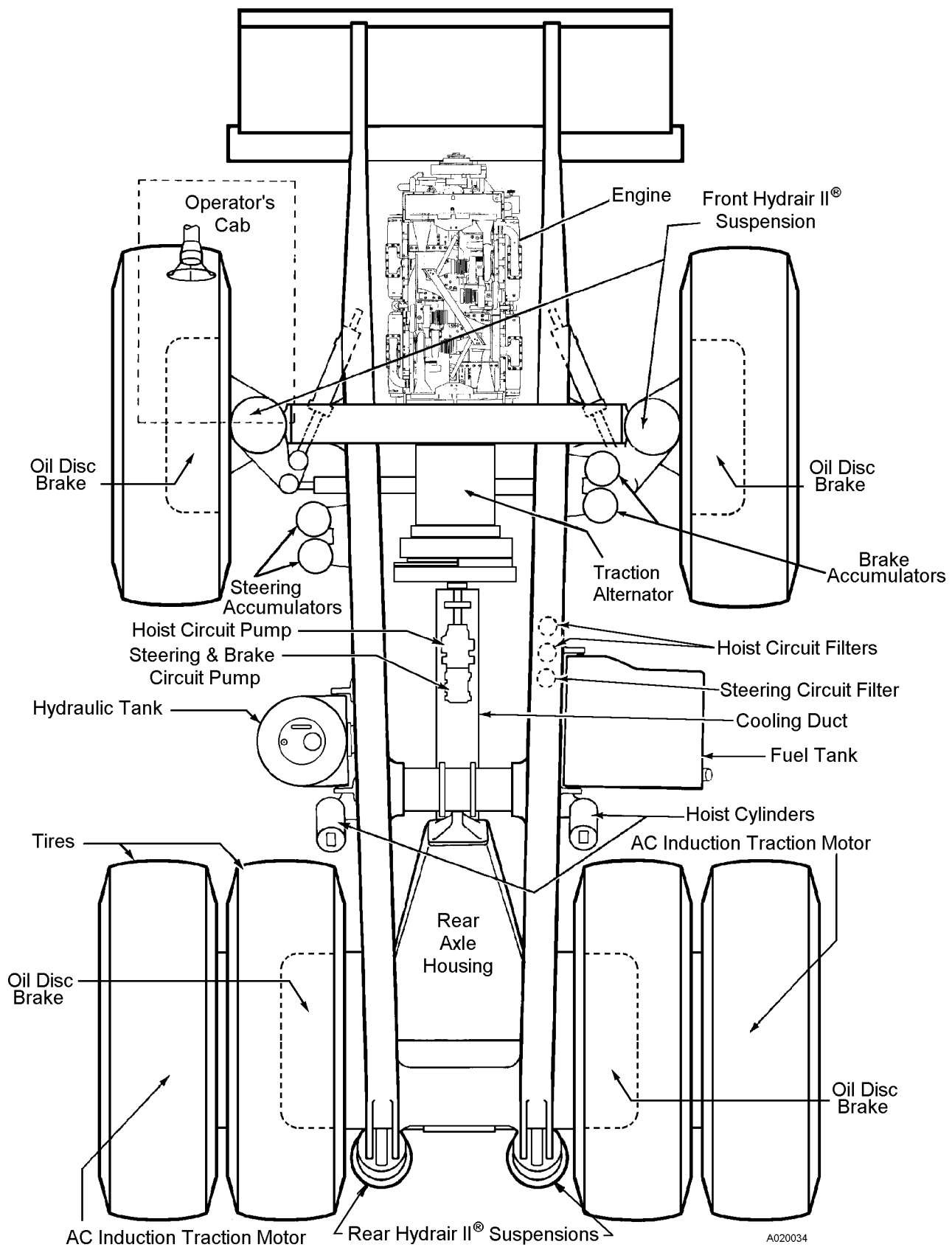

930E MAJOR COMPONENTS

SPECIFICATIONS

These specifications are for the standard Komatsu 930E truck. Customer options may change this listing.

ENGINE

Komatsu SSDA16V160

No. of Cylinders	16
Operating Cycle	4-Stroke
Low Idle	1750 rpm
High Idle	1910 rpm
Full Load	1900 rpm
Rated Brake HP	2700 HP (2014 kW) @ 1900 RPM
Flywheel HP	2550 HP (1902 kW) @ 1900 RPM
Weight* (Dry)	21,182 pounds (9608 kg)

* Weight does not include Radiator, Sub-frame, or Alternator

AC ELECTRIC DRIVE SYSTEM

(AC/DC Current)

Alternator	General Electric GTA - 42
Dual Impeller, In-Line Blower	12,000 cfm (340 m ³ /min)
Motorized Wheels	GDY106 AC Induction Traction Motors
	Wheel Slip/Slide Control
Standard Gear Ratio*	32.62:1
Maximum Speed	40 MPH (64.5 km/h)

*NOTE: Wheel motor application depends upon GVW, haul road grade and length, rolling resistance, and other parameters. Komatsu & G.E. must analyze each job condition to assure proper application.

DYNAMIC RETARDING

Electric Dynamic Retarding	Standard
Maximum Rating	5400 HP (4026 kW)
Continuous	3300 HP (2460 kW)

Continuously rated high-density blown grids with retard at engine idle and retard in reverse propulsion.

BATTERY ELECTRIC SYSTEM

Batteries	bumper mounted
	4 x 8D & 2 x 30H 12 Volt Batteries in Series/Parallel
	220 Ampere-Hour Capacity
	With Disconnect Switch
Alternator	26 Volt, 260 Ampere Output
Lighting	24 Volt
Starters (2)	24 Volt

SERVICE CAPACITIES

	U.S. Gallons	(Liters)
Crankcase *	74	280
* Includes Lube Oil Filters		
Cooling System	157	594
Fuel	1200	4542
Hydraulic System	350	1325
Wheel Motor Gear Box	.25/Wheel	.95/Wheel

HYDRAULIC SYSTEMS

Hoist & Brake Cooling Pump:	Tandem Gear
Rated @	246 GPM (931 l/min.) @ 1900 RPM
	and 2500 psi (17 237 kPa)
Steering/Brake Pump:	Pressure Compensated Piston
Rated @	65 GPM (246 l/min.) @ 1900 RPM
	and 2750 psi (18 961 kPa)
Relief Pressure-Hoist	2500 psi (17.2 MPa)
Relief Pressure-Steering/Brake	4000 psi (27.6 MPa)
Hoist Cylinders (2)	3-Stage Hydraulic
Tank (Vertical/Cylindrical)	Non-Pressurized
Tank Capacity	250 US Gal. (947 Liters)
Filtration	In-line replaceable elements
Suction	Single, Full Flow, 100 Mesh
Hoist & Steering Filters	Beta ₁₂ Rating =200
	Dual In-Line, High Pressure

SERVICE BRAKES

All Hydraulic Actuation	with Traction System
	Wheel Slip / Slide Control
Front & Rear Oil-Cooled Multiple Discs-	each wheel
Total Friction Area / Brake	15,038 in ² (97 019 cm ²)
Maximum Apply Pressure	2500 psi (17 238 kPa)

STEERING

Turning Circle (SAE)	97 ft. 7 in. (30.4 m)
Twin hydraulic cylinders with accumulator assist to provide constant rate steering.	
Emergency power steering automatically provided by accumulators.	

STANDARD DUMP BODY CAPACITIES AND DIMENSIONS

Capacity,

Heaped @ 2:1 (SAE)	276 yd ³ (211 m ³)
Struck	224 yd ³ (171 m ³)
Width (Inside)	26 ft. 9 in. (8.15 m)
Depth	10 ft. 7 in. (3.2 m)
Loading Height	23 ft. (7.01 m)
Dumping Angle	45°

TIRES

Radial Tires (standard)	53/80 R63
.	Rock Service, Tubeless
Rims	(patented Phase I rims)

WEIGHT DISTRIBUTION

Empty Vehicle Pounds . . . (Kilograms)
Front Axle (49.3%) 226,699 (102 830)
Rear Axle (50.7%) 233,137 (105 750)
Total (50% Fuel) 459,836 (208 580)

Loaded Vehicle Pounds . . . (Kilograms)
Front Axle (33.9%) 363,000 (164 656)
Rear Axle (66.1%) 737,000 (334 301)
Total * 1,100,000 (498 957)

*Not to exceed 1,100,000 lbs. (498 957 kg) including options, fuel, and payload. Weights in excess of this amount require factory approval.

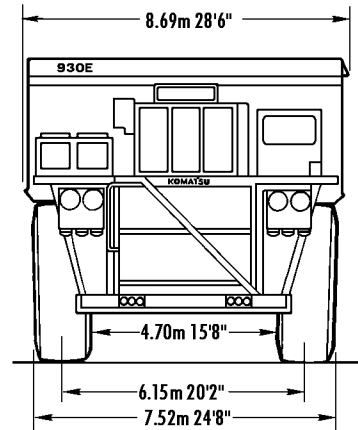
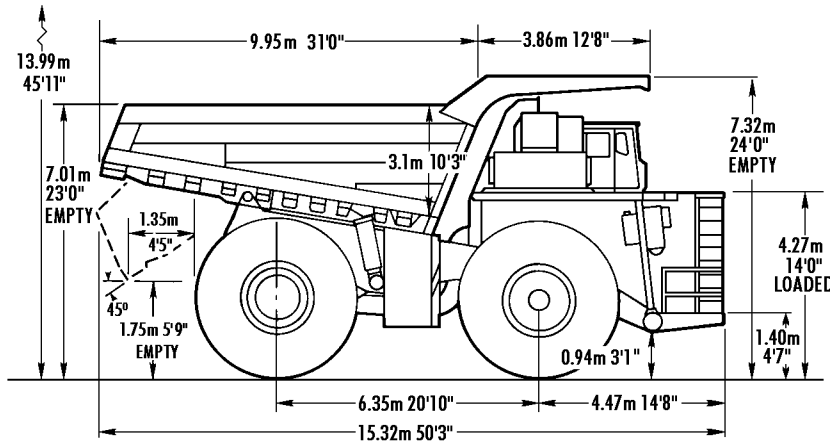

All Dimensions with 171/211m³ 224/276 yd³ Body

BODIES	Struck		2:1 Heap		Loading Height	
	M ³	Yd ³	M ³	Yd ³	M	Feet
Standard	171	224	211	276	7.01	23'0"

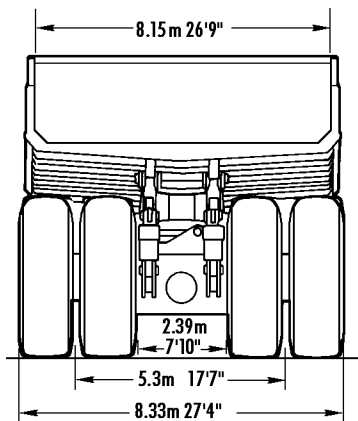

A020025

SECTION A3

GENERAL SAFETY AND OPERATING INSTRUCTIONS

INDEX

GENERAL SAFETY	A3-3
Safety Rules	A3-3
Safety Features	A3-3
Clothing And Personal Items	A3-3
Unauthorized Modification	A3-3
Leaving The Operator's Seat	A3-4
Mounting And Dismounting	A3-4
Fire Prevention For Fuel And Oil	A3-4
Precautions When Handling At High Temperatures	A3-5
Asbestos Dust Hazard Prevention	A3-5
Prevention Of Injury By Work Equipment	A3-5
Fire Extinguisher And First Aid Kit	A3-5
Precautions When Using ROPS	A3-6
Precautions For Attachments	A3-6
PRECAUTIONS DURING OPERATION	A3-7
Safety Is Thinking Ahead	A3-7
Safety At The Worksite	A3-7
Fire Prevention	A3-7
Preparing For Operation	A3-7
Ventilation For Enclosed Areas	A3-7
In Operator's Cab - Before Starting The Engine	A3-8
Mirrors, Windows, And Lights	A3-8
OPERATING THE MACHINE	A3-8
When Starting The Engine	A3-8
Truck Operation - General	A3-8
Check When Traveling In Reverse	A3-9
Traveling	A3-9
Traveling On Slopes	A3-10
Ensure Good Visibility	A3-10
Operate Carefully On Snow	A3-10
Avoid Damage To Dump Body	A3-10
Driving Near High Voltage Cables	A3-10
When Dumping	A3-11
Working On Loose Ground	A3-11
When Loading	A3-11
Parking The Machine	A3-11
TOWING	A3-11
WORKING NEAR BATTERIES	A3-12
Starting With Booster Cables	A3-12
PRECAUTIONS FOR MAINTENANCE	A3-13
BEFORE PERFORMING MAINTENANCE	A3-13
Warning Tag	A3-13
Proper Tools	A3-13

Stopping The Engine Before Service	A3-13
Securing The Dump Body	A3-13
DURING MAINTENANCE	A3-14
Personnel	A3-14
Attachments	A3-14
Working Under The Machine	A3-14
Keep The Machine Clean	A3-14
Rules To Follow When Adding Fuel Or Oil	A3-14
Radiator Water Level	A3-15
Use Of Lighting	A3-15
Precautions With The Battery	A3-15
Handling High Pressure Hoses	A3-15
Precautions With High Pressure Oil	A3-15
Precautions When Performing Maintenance At High Temperature Or High Pressure	A3-16
Rotating Fan And Belts	A3-16
Waste Materials	A3-16
TIRES	A3-17
Handling Tires	A3-17
Storing Tires After Removal	A3-17
ADDITIONAL JOB SITE RULES	A3-18
WHEN REPAIRS ARE NECESSARY	A3-19
SPECIAL PRECAUTIONS FOR WORKING ON A 930E TRUCK	A3-20
Preliminary Procedures before Welding or Performing Maintenance	A3-20
Normal Engine Shutdown Procedure	A3-20
Engine Shutdown Procedure before Welding or Performing Maintenance	A3-21
TRUCK OPERATION	A3-23
PREPARING FOR OPERATION	A3-23
Safety Is Thinking Ahead	A3-23
At The Truck - Ground Level Walk Around Inspection	A3-23
ENGINE START-UP SAFETY PRACTICES	A3-26
Cold Weather Starting	A3-27
AFTER ENGINE HAS STARTED	A3-27
MACHINE OPERATION SAFETY PRECAUTIONS	A3-28
MACHINE OPERATION ON THE HAUL ROAD	A3-28
DYNAMIC RETARDING OPERATION	A3-29
Dynamic Retarder Control Lever	A3-29
Dynamic Retarder/Service Brake Pedal	A3-29
Starting On A Grade With A Loaded Truck	A3-30
PASSING	A3-30
LOADING	A3-30
DUMPING	A3-30
Raising The Dump Body	A3-30
Lowering The Dump Body	A3-31
TOWING	A3-32
SAFE PARKING PROCEDURES	A3-33
NORMAL ENGINE SHUTDOWN PROCEDURE	A3-33
DELAYED ENGINE SHUTDOWN PROCEDURE	A3-33
SUDDEN LOSS OF ENGINE POWER	A3-34

GENERAL SAFETY

Safety records of most organizations will show that the greatest percentage of accidents are caused by unsafe acts of persons. The remainder are caused by unsafe mechanical or physical conditions. Report all unsafe conditions to the proper authority.

The following safety rules are provided as a guide for the operator. However, local conditions and regulations may add many more to this list.



Read and follow all safety precautions. Failure to do so may result in serious injury or death.

Safety Rules

- Only trained and authorized personnel can operate and maintain the machine.
- Follow all safety rules, precautions and instructions when operating or performing maintenance on the machine.
- When working with another operator or a person on work site traffic duty, be sure all personnel understand all hand signals that are to be used.

Safety Features

- Ensure all guards and covers are in their proper position. Have any damaged guards and covers repaired. (See Walk-Around Inspection, Operating Instructions - Section 3)
- Learn the proper use of safety features such as safety locks, safety pins, and seat belts, and use these safety features properly.
- Never remove any safety features. Always keep them in good operating condition.
- Improper use of safety features could result in serious bodily injury or death.

Clothing And Personal Items

- Avoid loose clothing, jewelry, and loose long hair. They can catch on controls or in moving parts and cause serious injury or death. Additionally, never wear oily clothes as they are flammable.
- Wear a hard hat, safety glasses, safety shoes, mask and gloves when operating or maintaining a machine. Always wear safety goggles, hard hat and heavy gloves if your job involves scattering metal chips or minute materials--particularly when driving pins with a hammer or when cleaning air cleaner elements with compressed air. Also, ensure that the work area is free from other personnel during such tasks.

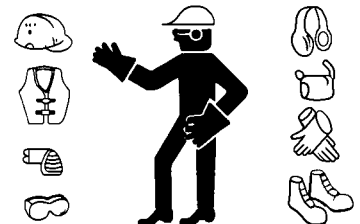

A0055010

Unauthorized Modification

- Any modification made to this vehicle without authorization from Komatsu America Corp. can possibly create hazards.
- Before making any modification, consult the authorized regional Komatsu America Corp. distributor. Komatsu will not be responsible for any injury or damage caused by any unauthorized modification.

Leaving The Operator's Seat

- When preparing to leave the operator's seat, do not touch any control lever that is not locked. To prevent accidental operations from occurring, always perform the following:
- Move the shift control lever to NEUTRAL and apply the parking brake.
- Lower the dump body, set the dump lever to the FLOAT position.
- Stop the engine. When exiting the machine, always lock compartments, and take the keys with you. If the machine should suddenly move or move in an unexpected way, this may result in serious bodily injury or death.

Mounting And Dismounting

- Never jump on or off the machine. Never climb on or off a machine while it is moving.
- When climbing on or off a machine, face the machine and use the hand-hold and steps.
- Never hold any control levers when getting on or off a machine.
- Always maintain three-point contact with the hand-holds and steps to ensure that you support yourself.
- When bringing tools into the operator's compartment, always pass them by hand or pull them up by rope.
- If there is any oil, grease, or mud on the hand-holds or steps, wipe them clean immediately. Always keep these components clean. Repair any damage and tighten any loose bolts.
- Use the handrails and steps marked by arrows in the diagram below when getting on or off the machine.

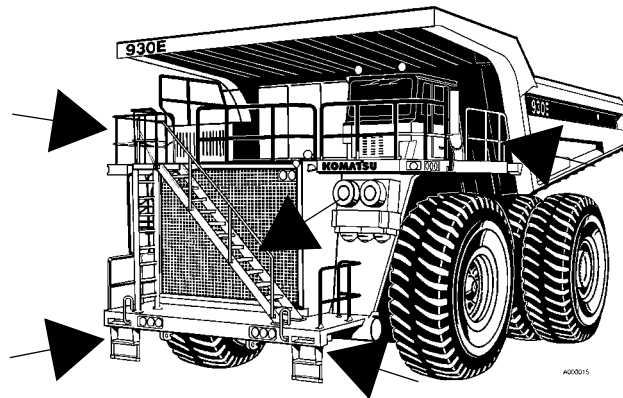

Fire Prevention For Fuel And Oil

- Fuel, oil, and antifreeze can be ignited by a flame. Fuel is extremely flammable and can be hazardous.
- Keep flames away from flammable fluids.
- Stop the engine and never smoke when refueling.
- Tighten all fuel and oil tank caps securely.
- Refueling and oiling should be done in well ventilated areas.
- Keep oil and fuel in a designated location and do not allow unauthorized persons to enter.



Precautions When Handling At High Temperatures

- Immediately after machine operation, engine coolant, engine oil, and hydraulic oil are at high temperatures and are pressurized. If the cap is removed, the fluids drained, the filters are replaced, etc., there is danger of serious burns. Allow the heat and pressure to dissipate before performing such tasks and follow proper procedures as outlined in the service manual.
- To prevent hot coolant from spraying:
 - 1) Stop the engine.
 - 2) Wait for the coolant temperature to decrease.
 - 3) Turn the radiator cap slowly to release the pressure before removing.
- To prevent hot engine oil spray:
 - 1) Stop the engine.
 - 2) Wait for the oil temperature to cool down.
 - 3) Turn the cap slowly to release the pressure before removing the cap.



Asbestos Dust Hazard Prevention

Asbestos dust is hazardous to your health when inhaled. If you handle materials containing asbestos fibers, follow the guidelines below:

- Never use compressed air for cleaning.
- Use water for cleaning to control dust.
- Operate the machine or perform tasks with the wind to your back, whenever possible.
- Use an approved respirator when necessary.

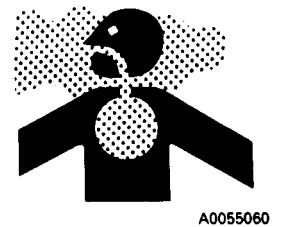

Prevention Of Injury By Work Equipment

- Never enter or put your hand or arm or any other part of your body between movable parts such as the dump body, chassis or cylinders. If the work equipment is operated, clearances will change and may lead to serious bodily injury or death.

Fire Extinguisher And First Aid Kit

- Ensure fire extinguishers are accessible and proper usage techniques are known.
- Provide a first aid kit at the storage point.
- Know what to do in the event of a fire.
- Keep the phone numbers of persons you should contact in case of an emergency on hand.

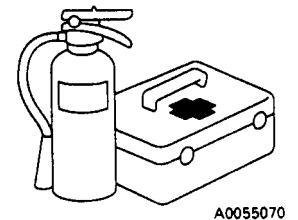

Precautions When Using ROPS

- The Rollover Protection Structure (ROPS) must be properly installed for machine operation.
- The ROPS is intended to protect the operator if the machine should roll over. It is designed not only to support the load of the machine, but also to absorb the energy of the impact.
- ROPS structures installed on equipment manufactured and designed by Komatsu America Corp. fulfill all of the regulations and standards for all countries. If it is modified or repaired without authorization from Komatsu, or is damaged when the machine rolls over, the strength of the structure will be compromised and will not be able to fulfill its intended purpose. Optimum strength of the structure can only be achieved if it is repaired or modified as specified by Komatsu.
- When modifying or repairing the ROPS, always consult your nearest Komatsu distributor.
- Even with the ROPS installed, the operator must always use the seat belt when operating the machine.

Precautions For Attachments

- When installing and using optional equipment, read the instruction manual for the attachment and the information related to attachments in this manual.
- Do not use attachments that are not authorized by Komatsu America Corp., or the authorized regional Komatsu distributor. Use of unauthorized attachments could create a safety problem and adversely affect the proper operation and useful life of the machine.
- Any injuries, accidents, and product failures resulting from the use of unauthorized attachments will not be the responsibility of Komatsu America Corp., or the authorized regional Komatsu distributor.