

Shop Manual

BULLDOZER

D65EX -17

D65PX -17

D65WX -17

SERIAL NUMBERS

D65EX- 1001

D65PX- 1001

D65WX-1001

and up

KOMATSU

Bulldozer

D65EX-17 D65PX- 17 D65WX-17

| Model | Serial Number |
|-------|---------------|
|-------|---------------|

| | |
|----------------------------------|-------------|
| D65EX-17 D65PX-17 D65WX-17 | 1001 and up |
|----------------------------------|-------------|

00 Index and foreword

Index

| | |
|---|--------|
| 00 Index and foreword | 00-1 |
| Index | 00-2 |
| Foreword, safety and general information | 00-15 |
| Important safety notice | 00-15 |
| How to read the shop manual | 00-20 |
| Explanation of terms for maintenance standard | 00-22 |
| Handling of fuel system devices | 00-24 |
| Handling of intake system parts | 00-25 |
| Handling of hydraulic equipment | 00-26 |
| Method of disconnecting and connecting push-pull type coupler | 00-28 |
| Handling of electrical equipment | 00-31 |
| How to read electric wire code | 00-39 |
| Precautions when performing operation | 00-42 |
| Standard tightening torque table | 00-45 |
| List of abbreviation | 00-49 |
| Conversion table | 00-53 |
| 01 Specification | 01-2 |
| Specifications | 01-3 |
| Specification drawing | 01-3 |
| Specifications | 01-6 |
| Weight table | 01-30 |
| Table of fuel, coolant and lubricants | 01-38 |
| 10 Structure and function | 10-3 |
| Engine and cooling system | 10-4 |
| Engine related parts | 10-4 |
| Damper | 10-6 |
| Cooling system | 10-8 |
| Cooling fan pump | 10-10 |
| Cooling fan motor | 10-24 |
| Power train | 10-32 |
| Power train | 10-32 |
| HSS system | 10-35 |
| Overall drawing of power train unit | 10-37 |
| Power train mount | 10-39 |
| Power train hydraulic piping drawing | 10-40 |
| Transmission, steering, and brake control | 10-42 |
| Universal joint | 10-44 |
| Torque converter and PTO | 10-45 |
| Transmission | 10-51 |
| Transmission control valve | 10-64 |
| Forward and reverse clutch ECMV and gear shift clutch ECMV | 10-66 |
| Lockup clutch ECMV | 10-73 |
| Main relief valve and torque converter relief valve | 10-77 |
| Transmission lubricating oil relief valve | 10-80 |
| Bevel gear shaft, HSS, and brake | 10-81 |
| Brake valve | 10-102 |
| Final drive | 10-106 |
| Undercarriage and frame | 10-110 |
| Main frame | 10-110 |
| Suspension | 10-112 |
| Track frame and idler cushion | 10-114 |
| Hydraulic system | 10-116 |
| Hydraulic piping drawing | 10-116 |
| Work equipment control | 10-120 |
| Hydraulic tank | 10-122 |
| CLSS | 10-124 |
| Scavenging pump | 10-127 |

| | |
|---|--------|
| Steering lubricating oil pump and power train pump..... | 10-128 |
| HSS pump..... | 10-129 |
| HSS motor | 10-150 |
| Control valve | 10-159 |
| Blade PPC valve..... | 10-186 |
| Ripper PPC valve..... | 10-194 |
| Quick drop valve | 10-198 |
| Work equipment lock solenoid valve | 10-201 |
| Pitch selector solenoid valve | 10-206 |
| Angle control EPC valve | 10-207 |
| Hydraulic oil cooler bypass valve..... | 10-212 |
| PPC accumulator..... | 10-213 |
| Work equipment | 10-214 |
| Work equipment..... | 10-214 |
| Ripper..... | 10-217 |
| Piston valve..... | 10-218 |
| Cab and its attachments..... | 10-220 |
| ROPS cab | 10-220 |
| Cab mount | 10-222 |
| Electrical system | 10-223 |
| Engine control system | 10-223 |
| Cooling system control system..... | 10-226 |
| Palm command control system..... | 10-228 |
| Machine monitor system..... | 10-232 |
| KOMTRAX system..... | 10-252 |
| System component part..... | 10-255 |
| Sensors | 10-270 |
| 20 Standard value table | 20-2 |
| Standard service value table..... | 20-3 |
| Standard value table for engine | 20-3 |
| Standard value table for machine | 20-5 |
| 30 Testing and adjusting | 30-3 |
| General information on testing and adjusting..... | 30-4 |
| Tools for testing, adjusting, and troubleshooting..... | 30-4 |
| Engine and cooling system..... | 30-8 |
| Testing engine speed | 30-8 |
| Measuring boost pressure..... | 30-10 |
| Measuring exhaust gas temperature | 30-11 |
| Measuring exhaust gas color..... | 30-13 |
| Measuring and adjusting valve clearance..... | 30-15 |
| Measuring compression pressure..... | 30-17 |
| Measuring blowby pressure | 30-19 |
| Measuring engine oil pressure..... | 30-21 |
| Measuring EGR valve and KVGT oil pressure..... | 30-22 |
| Releasing remaining pressure from fuel system..... | 30-23 |
| Measuring fuel pressure | 30-24 |
| Measuring fuel delivery, return rate and leakage | 30-31 |
| Handling cylinder cutout mode operation..... | 30-35 |
| Handling no injection cranking operation | 30-36 |
| Bleeding air from fuel system | 30-37 |
| Checking fuel circuit for leakage | 30-38 |
| Testing and adjusting air conditioner compressor belt tension | 30-39 |
| Replacing alternator belt..... | 30-40 |
| Adjusting fuel dial and decelerator pedal | 30-41 |
| Power train system | 30-43 |
| Measuring power train oil pressure | 30-43 |
| Adjusting transmission output shaft speed sensor (replacement procedure)..... | 30-48 |
| Simple test procedure for brake performance | 30-49 |
| Adjusting brake pedal | 30-50 |

| | |
|---|--------|
| Adjusting parking brake lever | 30-52 |
| Retrieval of disabled machine using brake release device | 30-54 |
| Undercarriage and frame | 30-57 |
| Adjusting idler clearance | 30-57 |
| Checking sprocket wear | 30-58 |
| Checking and adjusting track shoe tension | 30-59 |
| Hydraulic system | 30-60 |
| Releasing remaining pressure in work equipment cylinder | 30-60 |
| Measuring and adjusting work equipment and HSS oil pressure | 30-61 |
| Measuring source pressure of control circuit | 30-64 |
| Measuring PPC valve output pressure | 30-65 |
| Adjusting play of work equipment PPC valve | 30-68 |
| Isolating the parts causing hydraulic drift in blade and ripper | 30-70 |
| Measure internal oil leakage of work equipment cylinder | 30-71 |
| Checking fan speed | 30-72 |
| Measuring fan circuit oil pressure | 30-73 |
| Bleeding air from hydraulic circuit | 30-74 |
| Work equipment | 30-76 |
| Adjusting work equipment lock lever | 30-76 |
| Adjustment of straight tilt dozer | 30-77 |
| Cab and its attachments | 30-79 |
| Adjusting operator's cab | 30-79 |
| Adjusting play of blade center ball | 30-82 |
| Electrical system | 30-83 |
| Special functions of machine monitor | 30-83 |
| Handling voltage circuit of engine controller | 30-143 |
| Adjustment method when controller has been replaced | 30-144 |
| Testing diodes | 30-146 |
| Pm clinic | 30-147 |
| Pm Clinic service | 30-147 |
| Pm Clinic check sheet | 30-153 |
| 40 Troubleshooting | 40-8 |
| General information on troubleshooting | 40-9 |
| Instruction on troubleshooting | 40-9 |
| How to proceed troubleshooting | 40-11 |
| Check before troubleshooting | 40-12 |
| Testing procedure before troubleshooting | 40-14 |
| Classification and procedure for troubleshooting | 40-23 |
| Classification and procedures for troubleshooting numbers | 40-25 |
| Information mentioned in troubleshooting table | 40-28 |
| Troubleshooting method for open circuit in wiring harness of pressure sensor system | 40-30 |
| Connector list and layout | 40-32 |
| Connector contact identification | 40-45 |
| T-branch box and T-branch adapter table | 40-82 |
| Fuse locations table | 40-88 |
| Precautions for cleaning and replacing KDPF (KCSF, KDOC) | 40-91 |
| Troubleshooting by failure code (Display of code) | 40-93 |
| Failure codes table | 40-93 |
| Failure code [1500L0] Transmission clutch:Abnormal | 40-104 |
| Failure code [15SAL1] Forward clutch:Fill High | 40-105 |
| Failure code [15SALH] Forward clutch:Fill Low | 40-107 |
| Failure code [15SBL1] Reverse clutch:Fill High | 40-109 |
| Failure code [15SBLH] Reverse clutch:Fill Low | 40-111 |
| Failure code [15SEL1] Speed 1st clutch:Fill High | 40-113 |
| Failure code [15SELH] Speed 1st clutch:Fill Low | 40-115 |
| Failure code [15SFL1] Speed 2nd clutch:Fill High | 40-117 |
| Failure code [15SFLH] Speed 2nd clutch:Fill Low | 40-119 |
| Failure code [15SGL1] Speed 3rd clutch:Fill High | 40-121 |
| Failure code [15SGLH] Speed 3rd clutch:Fill Low | 40-123 |

| | |
|--|--------|
| Failure code [15S JL1] L/U :Fill Hihg | 40-125 |
| Failure code [15S JLH] L/U :Fill low | 40-127 |
| Failure code [1800MW] P/L clutch:Slip | 40-129 |
| Failure code [879AKA] Air Conditioner Inner Sensor Disconnection | 40-130 |
| Failure code [879AKB] Air Conditioner Inner Sensor Disconnection | 40-131 |
| Failure code [879BKA] Air Conditioner Outside Air Sensor Disconnection | 40-132 |
| Failure code [879BKB] Air Conditioner Outside Air Sensor Disconnection | 40-133 |
| Failure code [879CKA] Ventilating Sensor Disconnection | 40-134 |
| Failure code [879CKB] Ventilating Sensor Short Circuit | 40-135 |
| Failure code [879DKZ] Sunlight Sensor Open Or Short Circuit | 40-136 |
| Failure code [879EMC] Ventilation Abnormal | 40-137 |
| Failure code [879FMC] A/M Damper Abnormal | 40-138 |
| Failure code [879GKX] Refrigerant Abnormality | 40-139 |
| Failure code [989L00] Engine Controller Lock Caution 1 | 40-140 |
| Failure code [989M00] Engine Controller Lock Caution 2 | 40-141 |
| Failure code [989N00] Engine Controller Lock Caution 3 | 40-142 |
| Failure code [A1U0N3]: KDPF Dry Request (HC Release) | 40-143 |
| Failure code [A1U0N4] KDPF Dry Request (HC Release) | 40-145 |
| Failure code [AA10NX] Air Cleaner Clogging | 40-147 |
| Failure code [AB00KE] Battery Charge Voltage Low | 40-148 |
| Failure code [B@BAZG] Engine Oil Pressure Low | 40-150 |
| Failure code [B@BCNS] Eng Water Overheat | 40-151 |
| Failure code [B@CENS] P/L Oil Overheat | 40-152 |
| Failure code [B@HANS] Hyd Oil Overheat | 40-153 |
| Failure code [CA115] Eng Ne and Bkup Speed Sens Error | 40-154 |
| Failure code [CA122] Chg Air Press Sensor High Error | 40-155 |
| Failure code [CA123] Chg Air Press Sensor Low Error | 40-157 |
| Failure code [CA131] Throttle Sensor High Error | 40-159 |
| Failure code [CA132] Throttle Sensor Low Error | 40-161 |
| Failure code [CA144] Coolant Temp Sens High Error | 40-163 |
| Failure code [CA145] Coolant Temp Sens Low Error | 40-165 |
| Failure code [CA153] Chg Air Temp Sensor High Error | 40-167 |
| Failure code [CA154] Chg Air Temp Sensor Low Error | 40-169 |
| Failure code [CA187] Sensor 2 Supply Volt Low Error | 40-171 |
| Failure code [CA234] Eng Overspeed | 40-173 |
| Failure code [CA221] Ambient Press Sens High Error | 40-174 |
| Failure code [CA222] Ambient Press Sens Low Error | 40-176 |
| Failure code [CA227] Sens Supply 2 Volt High Error | 40-178 |
| Failure code [CA238] Ne Speed Sens Supply Volt Error | 40-179 |
| Failure code [CA239] Ne Speed Sens Supply Volt High Error | 40-180 |
| Failure code [CA271] IMV/PCV1 Short Error | 40-182 |
| Failure code [CA272] IMV/PCV1 Open Error | 40-184 |
| Failure code [CA281] Pump Press Balance Error | 40-186 |
| Failure code [CA295] Ambient Pressure Sensor In Range Error | 40-187 |
| Failure code [CA322] Inj #1(L#1) Open/Short Error | 40-188 |
| Failure code [CA323] Inj #5 (L#5) Open/Short Error | 40-190 |
| Failure code [CA324] Inj #3(L#3) Open/Short Error | 40-192 |
| Failure code [CA325] Inj #6 (L#6) Open/Short Error | 40-194 |
| Failure code [CA331] Inj #2(L#2) Open/Short Error | 40-196 |
| Failure code [CA332] Inj #4 (L#4) Open/Short Error | 40-198 |
| Failure code [CA343] ECM Critical Internal Failure | 40-200 |
| Failure code [CA351] Injectors Drive Circuit Error | 40-201 |
| Failure code [CA352] Sensor 1 Supply Volt Low Error | 40-202 |
| Failure code [CA356] Mass Air Flow Sensor High Error | 40-204 |
| Failure code [CA357] Mass Air Flow Sensor Low Error | 40-206 |
| Failure code [CA386] Sens Supply 1 Volt High Error | 40-208 |
| Failure code [CA428] Water in Fuel Sensor High Error | 40-209 |
| Failure code [CA429] Water in Fuel Sensor Low Error | 40-211 |
| Failure code [CA435] Eng Oil Press SW Error | 40-213 |

| | |
|---|--------|
| Failure code [CA441] Battery Voltage Low Error | 40-214 |
| Failure code [CA442] Battery Voltage High Error | 40-216 |
| Failure code [CA449] Rail Press Very High Error | 40-217 |
| Failure code [CA451] Rail Press Sensor High Error | 40-219 |
| Failure code [CA452] Rail Press Sensor Low Error | 40-221 |
| Failure code [CA488] Chg Air Temp High Torque Derate | 40-223 |
| Failure code [CA515] Rail Press Sens Sup Volt High Error | 40-224 |
| Failure code [CA516] Rail Press Sens Sup Volt Low Error | 40-226 |
| Failure code [CA553] Rail Press High Error | 40-228 |
| Failure code [CA555] Crankcase Press High Error 2 | 40-229 |
| Failure code [CA556] Crankcase Pressure High Error 3 | 40-230 |
| Failure code [CA559] Rail Pump Press Low Error | 40-231 |
| Failure code [CA595] Turbocharger Speed High Error 2 | 40-235 |
| Failure code [CA687] Turbo Speed Low Error | 40-236 |
| Failure code [CA689] Eng Ne Speed Sensor Error | 40-238 |
| Failure code [CA691] Intake Air Temp Sens High Error | 40-242 |
| Failure code [CA692] Intake Air Temp Sens Low Error | 40-244 |
| Failure code [CA697] ECM Internal Temp Sensor High Error | 40-246 |
| Failure code [CA698] ECM Internal Temp Sensor Low Error | 40-247 |
| Failure code [CA731] Eng Bkup Speed Sens Phase Error | 40-248 |
| Failure code [CA778] Eng Bkup Speed Sensor Error | 40-250 |
| Failure code [CA1117] Engine Controller Partial Data Lost Error | 40-255 |
| Failure code [CA1664] KDOC Malfunction | 40-256 |
| Failure code [CA1691] Regeneration Ineffective | 40-258 |
| Failure code [CA1695] Sensor 5 Supply Volt High Error | 40-261 |
| Failure code [CA1696] Sensor 5 Supply Volt Low Error | 40-262 |
| Failure code [CA1843] Crankcase Press Sens High Error | 40-264 |
| Failure code [CA1844] Crankcase Press Sens Low Error | 40-266 |
| Failure code [CA1879] KDPF Delta P Sensor High Error | 40-268 |
| Failure code [CA1881] KDPF Delta P Sensor Low Error | 40-270 |
| Failure code [CA1883] KDPF Delta P Sens In Range Error | 40-272 |
| Failure code [CA1921] KDPF Soot Level High Error 1 | 40-275 |
| Failure code [CA1922] KDPF Soot Level High Error 2 | 40-277 |
| Failure code [CA1942] Crankcase Press Sensor In Range Error | 40-281 |
| Failure code [CA1993] KDPF Delta Pressure Low Error | 40-282 |
| Failure code [CA2185] Throt Sensor Sup Volt High Error | 40-283 |
| Failure code [CA2186] Throt Sensor Sup Volt Low Error | 40-285 |
| Failure code [CA2249] Rail Press Very Low Error | 40-287 |
| Failure code [CA2265] Fuel Feed Pump Open Error | 40-288 |
| Failure code [CA2266] Fuel Feed Pump Short Error | 40-290 |
| Failure code [CA2271] EGR Valve Pos Sens High Error | 40-292 |
| Failure code [CA2272] EGR Valve Pos Sens Low Error | 40-294 |
| Failure code [CA2288] Turbo Speed High Error 1 | 40-297 |
| Failure code [CA2311] IMV Solenoid Error | 40-298 |
| Failure code [CA2349] EGR Valve Solenoid Open Error | 40-299 |
| Failure code [CA2353] EGR Valve Solenoid Short Error | 40-301 |
| Failure code [CA2357] EGR Valve Servo Error | 40-303 |
| Failure code [CA2373] Exhaust Manifold Press Sens High error | 40-304 |
| Failure code [CA2374] Exhaust Manifold Press Sens Low error | 40-306 |
| Failure code [CA2375] EGR Orifice Temp Sens High Error | 40-308 |
| Failure code [CA2376] EGR Orifice Temp Sens Low Error | 40-310 |
| Failure code [CA2381] KVGt Pos Sens High Error | 40-312 |
| Failure code [CA2382] KVGt Pos Sens Low Error | 40-314 |
| Failure code [CA2383] KVGt Solenoid Open Error | 40-316 |
| Failure code [CA2386] KVGt Solenoid Short Error | 40-318 |
| Failure code [CA2387] KVGt Valve Servo Error | 40-320 |
| Failure code [CA2554] Exh Manifold Press Sens In Range error | 40-321 |
| Failure code [CA2555] Grid Htr Relay Volt Low Error | 40-322 |
| Failure code [CA2556] Grid Htr Relay Volt High Error | 40-324 |

| | |
|---|--------|
| Failure code [CA2637] KDOC Blocked..... | 40-326 |
| Failure code [CA2639] Manual Stationary Regeneration Request..... | 40-328 |
| Failure code [CA2961] EGR Orifice Temp High Error 1 | 40-331 |
| Failure code [CA2973] Chg Air Press Sensor In Range Error | 40-332 |
| Failure code [CA3133] KDPF Outlet Press Sens High Error | 40-333 |
| Failure code [CA3134] KDPF Outlet Press Sens Low Error..... | 40-335 |
| Failure code [CA3135] KDPF Outlet Press Sens In Range Error | 40-337 |
| Failure code [CA3251] KDOC Inlet Temp High Error..... | 40-340 |
| Failure code [CA3253] KDOC Temp Error - Non Regeneration | 40-343 |
| Failure code [CA3254] KDOC Outlet Temp High Error 1 | 40-344 |
| Failure code [CA3255] KDPF Temp Error - Non Regeneration..... | 40-347 |
| Failure code [CA3256] KDPF Outlet Temp High Error 1 | 40-348 |
| Failure code [CA3311] KDOC Outlet Temp High Error 2..... | 40-349 |
| Failure code [CA3312] KDPF Outlet Temp High Error 2 | 40-350 |
| Failure code [CA3313] KDOC Inlet Temp Sensor Low Error | 40-353 |
| Failure code [CA3314] KDOC Inlet Temp Sens High Error | 40-356 |
| Failure code [CA3315] KDOC Inlet Temp Sens In Range Error..... | 40-360 |
| Failure code [CA3316] KDOC Outlet Temp Sens Low Error | 40-364 |
| Failure code [CA3317] KDOC Outlet Temp Sens High Error..... | 40-367 |
| Failure code [CA3318] KDOC Outlet Temp Sens In Range Error | 40-371 |
| Failure code [CA3319] KDPF Outlet Temp Sens High Error | 40-375 |
| Failure code [CA3321] KDPF Outlet Temp Sens Low Error | 40-379 |
| Failure code [CA3322] KDPF Outlet Temp Sens In Range Error..... | 40-382 |
| Failure code [CA3419] Mass Air Flow Sensor Sup Volt High Error | 40-386 |
| Failure code [CA3421] Mass Air Flow Sensor Sup Volt Low Error | 40-388 |
| Failure code [CA3741] Rail Press Valve Trip Error..... | 40-390 |
| Failure code [D130KA] Neutral relay:Open | 40-391 |
| Failure code [D130KB] Neutral relay:Short circuit..... | 40-393 |
| Failure code [D19DKA] Amber light relay:Open | 40-395 |
| Failure code [D19DKB] Amber light relay:Short circuit | 40-397 |
| Failure code [D19JKZ] Personal Code Relay Abnormality..... | 40-399 |
| Failure code [D811MC] KOMTRAX Error..... | 40-402 |
| Failure code [D862KA] GPS Antenna Open Circuit | 40-403 |
| Failure code [D8ALKA] Operating Lamp Open Circuit(KOMTRAX) | 40-404 |
| Failure code [D8ALKB] Operating Lamp Short Circuit(KOMTRAX) | 40-406 |
| Failure code [D8AQKR] CAN2 Discon(KOMTRAX)..... | 40-407 |
| Failure code [DAF0MB] Monitor Memory Error..... | 40-408 |
| Failure code [DAF0MC] Monitor Malfunction..... | 40-409 |
| Failure code [DAF8KB] Camera Power Supply Short Circuit | 40-410 |
| Failure code [DAF9KQ] Model Selection Abnormality | 40-412 |
| Failure code [DAFGMC] GPS Module Error..... | 40-413 |
| Failure code [DAFLKA] Operating Lamp Open Circuit(Monitor) | 40-414 |
| Failure code [DAFLKB] Operating Lamp Short Circuit(Monitor) | 40-416 |
| Failure code [DAFQKR] CAN2 Discon | 40-417 |
| Failure code [DAZ9KQ] A/C Model Selection Abnormality..... | 40-418 |
| Failure code [DAZQKR] CAN2 Discon (Aircon ECU) | 40-419 |
| Failure code [DB2QKR] CAN2 Discon (Engine Con) | 40-423 |
| Failure code [DB2RKR] CAN1 Discon (Engine Con) | 40-428 |
| Failure code [DBE0KT] PT controller:Abnormality in controller..... | 40-433 |
| Failure code [DBE1KK] PT controller:Source voltage low | 40-434 |
| Failure code [DBE2KK] PT controller:Output voltage low | 40-436 |
| Failure code [DBE5KK] PT:Sensor volt 5V (0) Out of normal range | 40-438 |
| Failure code [DBE6KK] PT:Sensor volt 24V Out of normal range | 40-440 |
| Failure code [DBE7KK] PT:Sensor volt 5V (1) Out of normal range | 40-442 |
| Failure code [DBE9KQ] PT controller:Type select signal | 40-444 |
| Failure code [DBELKA] Operating Lamp Open Circuit(PT Con)..... | 40-445 |
| Failure code [DBELKB] Operating Lamp Short Circuit(PT Con)..... | 40-447 |
| Failure code [DBEQKR] CAN2 Discon (PT Con)..... | 40-448 |
| Failure code [DBERKR] CAN1 Discon (PT Con)..... | 40-449 |

00 Index and foreword

Index

| | |
|--|--------|
| Failure code [DD12KA] Shift up Sw:Open | 40-450 |
| Failure code [DD12KB] Shift up Sw:Short circuit | 40-452 |
| Failure code [DD13KA] Shift down Sw:Open | 40-454 |
| Failure code [DD13KB] Shift down Sw:Short circuit | 40-456 |
| Failure code [DD14KA] Parking lever Sw:Open | 40-458 |
| Failure code [DD14KB] Parking lever Sw:Short circuit | 40-460 |
| Failure code [DDKFL4] Left Angle Sw:Signal mismatch | 40-462 |
| Failure code [DDKGL4] Right Angle Sw:Signal mismatch | 40-464 |
| Failure code [DDKHKA] iB Sw:Open | 40-466 |
| Failure code [DDKHKB] iB Sw:Short circuit | 40-468 |
| Failure code [DDN7KA] Weq pitch SW: Open | 40-470 |
| Failure code [DDN7KB] Pitch select solenoid:Short circuit | 40-472 |
| Failure code [DDNLKA] Weq lock Sw:Open | 40-474 |
| Failure code [DDNLKB] Weq lock Sw:Short circuit | 40-476 |
| Failure code [DGS1KA] Hyd oil temp sensor:Open | 40-478 |
| Failure code [DGS1KX] Hyd oil temp: signal abnormal | 40-479 |
| Failure code [DGT1KA] T/C oil temp sensor:Open | 40-481 |
| Failure code [DGT1KX] T/C oil temp sensor:Out of normal range | 40-482 |
| Failure code [DH21KA] Weq pressure sensor:Open | 40-484 |
| Failure code [DH21KB] Work equipment pressure sensor:Hot Short | 40-486 |
| Failure code [DHA4KA] Air Cleaner Clogging Sensor Open Circuit | 40-488 |
| Failure code [DHTDKA] T/C pressure sensor:Open | 40-489 |
| Failure code [DHTDKB] T/C pressure sensor:Hot Short | 40-491 |
| Failure code [DK10KA] Fuel control Dial:Open | 40-493 |
| Failure code [DK10KB] Fuel control Dial:Short circuit | 40-495 |
| Failure code [DK30KA] ST lever1:Open | 40-497 |
| Failure code [DK30KB] ST lever:Hot Short | 40-499 |
| Failure code [DK30KX] ST lever:Main and Sub Error | 40-501 |
| Failure code [DK30KZ] ST lever:Main and Sub Error | 40-502 |
| Failure code [DK30L8] ST lever:Signal mismatch | 40-503 |
| Failure code [DK31KA] ST lever2:Open | 40-504 |
| Failure code [DK31KB] ST lever2:Hot Short | 40-506 |
| Failure code [DK40KA] Brake potentiometer:Open | 40-508 |
| Failure code [DK40KB] Brake potentiometer:Hot Short | 40-510 |
| Failure code [DK55KX] FR lever:Main and Sub Error | 40-512 |
| Failure code [DK55KZ] FR lever:Main and Sub Error | 40-513 |
| Failure code [DK55L8] FR lever:Signal mismatch | 40-514 |
| Failure code [DK56KA] FR lever1:Open | 40-515 |
| Failure code [DK56KB] FR lever1:Hot Short | 40-517 |
| Failure code [DK57KA] FR lever2:Open | 40-519 |
| Failure code [DK57KB] FR lever2:Hot Short | 40-521 |
| Failure code [DKH1KA] Pitch angle sensor:Open | 40-523 |
| Failure code [DKH1KB] Pitch angle sensor:Hot Short | 40-525 |
| Failure code [DLM3KA] Fan rev. sensor:Open | 40-527 |
| Failure code [DLM3MB] Fan control:Mismatch | 40-529 |
| Failure code [DLT3KA] T/M out-speed sensor:Open | 40-530 |
| Failure code [DLT3KB] T/M out-speed sensor:Short circuit | 40-532 |
| Failure code [DV20KB] Back-up alarm :Short Circuit | 40-533 |
| Failure code [DW5AKA] Pitch select solenoid:Disconnection | 40-535 |
| Failure code [DW5AKB] Pitch select solenoid:Short circuit | 40-536 |
| Failure code [DW5AKY] Pitch select solenoid:Hot short | 40-537 |
| Failure code [DW7BKA] Fan reverse solenoid:Open | 40-539 |
| Failure code [DW7BKB] Fan reverse solenoid:Short circuit | 40-541 |
| Failure code [DWN1KA] Hss EPC RH:Open | 40-542 |
| Failure code [DWN1KB] Hss EPC RH:Short circuit | 40-543 |
| Failure code [DWN1KY] Hss EPC RH:Hot short | 40-544 |
| Failure code [DWN2KA] Hss EPC LH:Open | 40-546 |
| Failure code [DWN2KB] Hss EPC LH:Short circuit | 40-547 |
| Failure code [DWN2KY] Hss EPC LH:Hot short | 40-548 |

| | |
|--|--------|
| Failure code [DWN5KA] Fan pump solenoid 1 :Open | 40-550 |
| Failure code [DWN5KB] Fan pump solenoid 1 :Short circuit | 40-551 |
| Failure code [DWN5KY] Fan pump solenoid 1: Hot short | 40-552 |
| Failure code [DXA2KA] TVC solenoid 1: Open | 40-554 |
| Failure code [DXA2KB] TVC solenoid 1: Short circuit | 40-555 |
| Failure code [DXA2KY] TVC solenoid 1: Hot short | 40-556 |
| Failure code [DXH1KA] Lock-up ECMV:Open..... | 40-558 |
| Failure code [DXH1KB] Lock-up ECMV: Short circuit | 40-560 |
| Failure code [DXH1KY] Lock-up ECMV: Hot short | 40-561 |
| Failure code [DXH4KA] 1st clutch ECMV:Open | 40-563 |
| Failure code [DXH4KB] 1st clutch ECMV:Short circuit | 40-564 |
| Failure code [DXH4KY] 1st clutch ECMV:Hot short | 40-565 |
| Failure code [DXH5KA] 2nd clutch ECMV:Open | 40-567 |
| Failure code [DXH5KB] 2nd clutch ECMV:Short circuit | 40-568 |
| Failure code [DXH5KY] 2nd clutch ECMV:Hot short | 40-569 |
| Failure code [DXH6KA] 3rd clutch ECMV:Open | 40-571 |
| Failure code [DXH6KB] 3rd clutch ECMV:Short circuit..... | 40-572 |
| Failure code [DXH6KY] 3rd clutch ECMV:Hot short..... | 40-573 |
| Failure code [DXH7KA] R clutch ECMV:Open | 40-575 |
| Failure code [DXH7KB] R clutch ECMV:Short circuit | 40-576 |
| Failure code [DXH7KY] R clutch ECMV:Hot short | 40-577 |
| Failure code [DXH8KA] F clutch ECMV:Open..... | 40-579 |
| Failure code [DXH8KB] F clutch ECMV:Short circuit..... | 40-580 |
| Failure code [DXH8KY] F clutch ECMV:Hot short..... | 40-581 |
| Failure code [DXJ4KA] Weq lock Sol.:Open | 40-583 |
| Failure code [DXJ4KB] Weq lock Sol.:Short circuit | 40-585 |
| Failure code [DXJCKA] Blade angle left EPC:Open..... | 40-586 |
| Failure code [DXJCKB] Blade angle left EPC:Short circuit | 40-587 |
| Failure code [DXJCKY] Blade angle left EPC:Hot short | 40-588 |
| Failure code [DXJDKA] Blade angle right EPC:Open | 40-590 |
| Failure code [DXJDKB] Blade angle right EPC:Short circuit | 40-591 |
| Failure code [DXJDKY] Blade angle right EPC:Hot short | 40-592 |
| Troubleshooting of electrical system (E-mode) | 40-594 |
| E-1 Engine does not start (Engine does not crank)..... | 40-594 |
| E-2 Manual preheating does not work | 40-600 |
| E-3 Automatic preheating does not work | 40-603 |
| E-4 While preheating is working, preheating monitor does not light up | 40-605 |
| E-5 When starting switch is turned to ON position, machine monitor displays nothing..... | 40-607 |
| E-6 When starting switch is turned to ON position (with engine stopped), basic check monitor lights up | 40-610 |
| E-7 Air cleaner clogging monitor lights up in yellow while engine is running | 40-611 |
| E-8 Charge level monitor lights up while engine is running | 40-612 |
| E-9 Engine coolant temperature monitor lights up while engine is running | 40-614 |
| E-10 Engine oil pressure monitor lights up while engine is running | 40-615 |
| E-11 Power train oil temperature monitor lights up while engine is running | 40-616 |
| E-12 Hydraulic oil temperature monitor lights up while engine is running | 40-617 |
| E-13 Engine coolant temperature gauge does not indicate correct temperature | 40-618 |
| E-14 Fuel level gauge does not indicate correct level | 40-619 |
| E-15 Power train oil temperature gauge (multi-gauge) does not indicate correct temperature | 40-621 |
| E-16 Hydraulic oil temperature gauge (multi-gauge) does not indicate correct temperature | 40-622 |
| E-17 Operation mode does not change | 40-623 |
| E-18 Gearshift mode does not change | 40-624 |
| E-19 Operating customize switch does not display customize screen | 40-625 |
| E-20 Modifying setting on customize screen does not change setting of machine | 40-626 |
| E-21 Reverse slow mode does not function properly | 40-627 |
| E-22 Alarm buzzer does not sound or does not stop sounding | 40-628 |
| E-23 While starting switch is in OFF position, service meter is not displayed | 40-629 |

| | |
|--|--------|
| E-24 Service mode cannot be selected | 40-630 |
| E-25 Horn does not sound | 40-631 |
| E-26 Horn does not stop sounding | 40-632 |
| E-27 Backup alarm does not sound | 40-633 |
| E-28 Backup alarm does not stop sounding | 40-635 |
| E-29 Headlamp does not light up | 40-636 |
| E-30 Rear lamp does not light up | 40-639 |
| E-31 No wiper operates continuously or intermittently | 40-641 |
| E-32 Front wiper does not operate (Failure in both continuous and intermittent operations) | 40-644 |
| E-33 Rear wiper does not operate (Failure in both continuous and intermittent operations) | 40-647 |
| E-34 Left door wiper does not operate (Failure of both continuous and intermittent operations) | 40-650 |
| E-35 Right door wiper does not operate (Failure of both continuous and intermittent operations) | 40-653 |
| E-36 KOMTRAX system does not operate properly | 40-656 |
| Troubleshooting of hydraulic and mechanical system (H-mode) | 40-658 |
| Information mentioned in troubleshooting table (H mode) | 40-658 |
| System diagram of hydraulic and mechanical system | 40-659 |
| List of Failure Mode and Cause | 40-661 |
| H-1 Machine lacks power (insufficient drawbar pull) | 40-664 |
| H-2 Machine cannot travel (at 2nd or 3rd speed) | 40-666 |
| H-3 Machine does not start at all gear speeds | 40-667 |
| H-4 Machine travels only in one direction, either forward or in reverse | 40-668 |
| H-5 Large time lag at gear shifting or directional selection | 40-669 |
| H-6 Machine cannot be steered (machine does not turn left or right) | 40-670 |
| H-7 Steering speed or power is insufficient | 40-671 |
| H-8 Brake does not operate | 40-672 |
| H-9 Torque converter does not lock up | 40-673 |
| H-10 Power train oil overheats | 40-674 |
| H-11 Unusual noise is heard from around HSS and work equipment pump or HSS motor | 40-675 |
| H-12 All work equipment operates slowly | 40-676 |
| H-13 All work equipment does not operate | 40-677 |
| H-14 Blade lift speed or power is low | 40-678 |
| H-15 Blade tilt speed or power is low | 40-679 |
| H-16 Blade angle speed or power is low | 40-680 |
| H-17 Ripper lift speed or power is low | 40-681 |
| H-18 Hydraulic drift of lifted blade is large | 40-682 |
| H-19 Hydraulic drift of tilted blade is large | 40-683 |
| H-20 Hydraulic drift of lifted ripper is large | 40-684 |
| H-21 Fans speed is abnormal (high, low, or no rotation) | 40-685 |
| H-22 Unusual noise is heard from around fan | 40-687 |
| Troubleshooting of engine (S-mode) | 40-688 |
| Information contained in troubleshooting table (S mode) | 40-688 |
| S-1 When starting switch is turned to START position, engine is not cranked | 40-689 |
| S-2 The engine cranks but exhaust smoke does not come out | 40-690 |
| S-3 Fuel is being injected but engine does not start (incomplete combustion: engine cranks but does not start) | 40-691 |
| S-4 Startability is poor | 40-692 |
| S-5 Engine does not pick up smoothly | 40-694 |
| S-6 Engine stops during operation | 40-696 |
| S-7 Engine runs rough or is unstable | 40-698 |
| S-8 Engine lacks power | 40-699 |
| S-9 Exhaust gas is black (KDPF gets clogged in a short time) | 40-701 |
| S-10 Engine oil consumption is excessive | 40-703 |
| S-11 Engine oil becomes contaminated early | 40-704 |
| S-12 Fuel consumption is excessive | 40-705 |

| | |
|---|--------|
| S-13 Oil is in coolant (or coolant spurts or coolant level goes down)..... | 40-706 |
| S-14 Oil pressure drops | 40-707 |
| S-15 Fuel mixes into engine oil | 40-708 |
| S-16 Water mixes into engine oil (milky) | 40-709 |
| S-17 Coolant temperature rises too high (overheating) | 40-710 |
| S-18 Unusual noise is made | 40-711 |
| S-19 Vibration is excessive | 40-712 |
| S-20 Air cannot be bled from fuel circuit | 40-713 |
| S-21 Frequent active regeneration..... | 40-714 |
| S-22 Active regeneration is long | 40-715 |
| S-23 White smoke is exhausted during active regeneration | 40-716 |
| 50 Disassembly and assembly | 50-3 |
| General information on disassembly and assembly..... | 50-4 |
| How to read this manual | 50-4 |
| Coating materials list | 50-6 |
| Special tool list..... | 50-10 |
| Sketches of special tools | 50-20 |
| Engine and cooling system | 50-35 |
| Removal and installation of supply pump assembly | 50-35 |
| Removal and installation of fuel injector assembly | 50-40 |
| Removal and installation of cylinder head assembly | 50-54 |
| Removal and installation of radiator assembly | 50-72 |
| Removal and installation of aftercooler and assembly | 50-77 |
| Removal and installation of hydraulic oil cooler assembly | 50-80 |
| Removal and installation of power train oil cooler assembly | 50-82 |
| Removal and installation of cooling fan drive assembly | 50-84 |
| Removal and installation of cooling fan motor assembly | 50-86 |
| Removal and installation of engine assembly | 50-88 |
| Removal and installation of damper assembly | 50-95 |
| Removal and installation of engine front seal | 50-98 |
| Removal and installation of engine rear seal..... | 50-101 |
| Removal and installation of engine hood assembly | 50-109 |
| Removal and installation of fuel tank assembly | 50-111 |
| Removal and installation of KDPF assembly..... | 50-113 |
| Disassembly and assembly of KDPF | 50-117 |
| Removal and installation of KCCV assembly | 50-125 |
| Removal and installation of air cleaner assembly | 50-129 |
| Power train..... | 50-130 |
| Removal and installation of power train unit assembly | 50-130 |
| Disconnecting and connecting of power train unit assembly | 50-135 |
| Disassembly and assembly of PTO | 50-140 |
| Disassembly and assembly of torque converter | 50-144 |
| Disassembly and assembly of TORQFLOW transmission..... | 50-153 |
| Disassembly and assembly of HSS | 50-177 |
| Removal and installation of final drive assembly | 50-196 |
| Disassembly and assembly of final drive | 50-198 |
| Undercarriage and frame..... | 50-211 |
| Removal and installation of track frame assembly | 50-211 |
| Removal and installation of idler assembly | 50-213 |
| Disassembly and assembly of idler | 50-215 |
| Removal and installation of recoil spring assembly..... | 50-219 |
| Disassembly and assembly of recoil spring | 50-220 |
| Removal and installation of track roller assembly | 50-224 |
| Disassembly and assembly of track roller..... | 50-225 |
| Removal and installation of carrier roller assembly | 50-228 |
| Disassembly and assembly of carrier roller..... | 50-229 |
| Separation and connection of track shoe assembly (Standard type track shoe) | 50-232 |
| Separation and connection of track shoe assembly (PLUS type track shoe) | 50-235 |
| Overall disassembly and assembly of track shoe (standard type track shoe) | 50-236 |

00 Index and foreword

Index

| | |
|--|--------|
| Overall disassembly and assembly of track shoe (PLUS type track shoe) | 50-249 |
| Disassembly and assembly of one link in field (standard type track shoe)..... | 50-261 |
| Disassembly and assembly of one link in field (PLUS type track shoe)..... | 50-268 |
| Removal and installation of pivot shaft assembly | 50-273 |
| Removal and installation of equalizer bar assembly | 50-274 |
| Disassembly and assembly of equalizer bar side bushing..... | 50-276 |
| Hydraulic system | 50-277 |
| Removal and installation of hydraulic tank assembly | 50-277 |
| Removal and installation of control valve assembly | 50-280 |
| Disassembly and assembly of control valve..... | 50-284 |
| Disassembly and assembly of blade PPC valve..... | 50-285 |
| Disassembly and assembly of ripper PPC valve | 50-286 |
| Removal and installation of HSS pump and cooling fan pump assembly | 50-287 |
| Removal and installation of steering lubrication pump and power train pump assembly | 50-289 |
| Removal and installation of cooling scavenging pump assembly | 50-291 |
| Removal and installation of HSS motor assembly | 50-292 |
| Disassembly and assembly of hydraulic cylinder..... | 50-294 |
| Work equipment | 50-300 |
| Removal and installation of blade assembly (ST-TPP dozer)..... | 50-300 |
| Removal and installation of blade assembly (PAT dozer) | 50-302 |
| Removal and installation of ripper assembly | 50-304 |
| Cab and its attachments | 50-307 |
| Removal and installation of ROPS cab assembly..... | 50-307 |
| Removal and installation of operator's cab glass (adhesion glass)..... | 50-313 |
| Removal and installation of operator's seat..... | 50-318 |
| Removal and installation of seat belt..... | 50-319 |
| Removal and installation of air conditioner unit assembly..... | 50-320 |
| Removal and installation of air conditioner compressor assembly..... | 50-324 |
| Electric system | 50-325 |
| Removal and installation of machine monitor assembly | 50-325 |
| Removal and installation of engine controller assembly | 50-326 |
| Removal and installation of power train controller assembly..... | 50-327 |
| Removal and installation of mass air flow and temperature sensor | 50-329 |
| Removal and installation of KOMTRAX terminal | 50-330 |
| 60 Maintenance standard | 60-2 |
| Engine and cooling system | 60-3 |
| Engine mount | 60-3 |
| Damper | 60-4 |
| Cooling system | 60-6 |
| Cooling fan pump..... | 60-7 |
| Cooling fan motor..... | 60-10 |
| Power train..... | 60-12 |
| Power train mount..... | 60-12 |
| Universal joint..... | 60-14 |
| Torque converter and PTO | 60-15 |
| Transmission | 60-18 |
| Transmission control valve..... | 60-22 |
| Forward-reverse clutch ECMV and gear shift clutch ECMV | 60-23 |
| Lockup clutch ECMV | 60-24 |
| Main relief valve and torque converter relief valve | 60-25 |
| Transmission lubricating oil relief valve | 60-26 |
| Bevel gear shaft, HSS, and brake | 60-27 |
| Brake valve | 60-32 |
| Final drive | 60-33 |
| Sprocket..... | 60-36 |
| Undercarriage and frame | 60-40 |
| Main frame | 60-41 |
| Suspension | 60-43 |

| | |
|--|--------|
| Track frame and idler cushion | 60-45 |
| Idler | 60-47 |
| Track roller | 60-49 |
| Carrier roller | 60-53 |
| Track shoe | 60-55 |
| Hydraulic system | 60-60 |
| Hydraulic tank | 60-60 |
| Scavenging pump | 60-61 |
| Steering lubricating pump and power train pump | 60-62 |
| HSS pump | 60-63 |
| HSS motor | 60-65 |
| Control valve | 60-67 |
| Blade PPC valve | 60-74 |
| Ripper PPC valve | 60-76 |
| Quick drop valve | 60-78 |
| Work equipment lock solenoid valve | 60-80 |
| Angle control EPC valve | 60-83 |
| Work equipment | 60-84 |
| Work equipment | 60-84 |
| Cutting edge and end bit | 60-92 |
| Ripper | 60-94 |
| Lift cylinder | 60-95 |
| Tilt cylinder | 60-96 |
| Pitch cylinder | 60-97 |
| Angle cylinder | 60-98 |
| Ripper cylinder | 60-99 |
| Cab and its attachments | 60-100 |
| Cab mount | 60-100 |
| 80 Appendix | 80-2 |
| Air conditioner | 80-3 |
| Precautions for refrigerant | 80-3 |
| Air conditioner component | 80-4 |
| Configuration and function of refrigeration cycle | 80-7 |
| Outline of refrigeration cycle | 80-8 |
| Air conditioner unit | 80-10 |
| Dual pressure switch | 80-16 |
| Air conditioner controller | 80-17 |
| Air conditioner compressor | 80-18 |
| Condenser | 80-19 |
| Receiver drier | 80-20 |
| Sunlight sensor | 80-21 |
| Outside air temperature sensor | 80-22 |
| Procedure for testing and troubleshooting | 80-23 |
| Circuit diagram and arrangement of connector pins | 80-25 |
| System diagram | 80-27 |
| Input and output signals of the air conditioner controller | 80-28 |
| Layout of air conditioner related parts and connectors | 80-30 |
| Testing air leakage (duct) | 80-39 |
| Testing with self-diagnosis function | 80-42 |
| How to enter the electrical system abnormality record screen in service mode of machine monitor | 80-43 |
| Testing vent (mode) changeover | 80-45 |
| Testing FRESH/RECIRC air changeover | 80-46 |
| Testing sunlight sensor | 80-47 |
| Testing (dual) pressure switch for refrigerant | 80-48 |
| Testing relays | 80-49 |
| Troubleshooting chart 1 | 80-50 |
| Troubleshooting chart 2 | 80-51 |
| Information mentioned in troubleshooting table | 80-54 |

00 Index and foreword

Index

| | |
|--|-------|
| Failure code list related to air conditioner..... | 80-55 |
| Failure code [879AKA] A/C Inner sensor Open Circuit..... | 80-56 |
| Failure code [879AKB] A/C Inner sensor Short Circuit..... | 80-57 |
| Failure code [879BKA] A/C Outer sensor Open Circuit..... | 80-58 |
| Failure code [879BKB] A/C Outer sensor Short Circuit..... | 80-60 |
| Failure code [879CKA] Ventilating sensor Open Circuit..... | 80-62 |
| Failure code [879CKB] Ventilating sensor Short Circuit..... | 80-63 |
| Failure code [879DKZ] Sunlight sensor Open or Short Circuit..... | 80-64 |
| Failure code [879EMC] Ventilating Damper Abnormality..... | 80-66 |
| Failure code [879FMC] Air Mix Damper Abnormality..... | 80-67 |
| Failure code [879GKX] Refrigerant Abnormality..... | 80-68 |
| A-1 Troubleshooting for power supply system (Air conditioner does not operate)..... | 80-69 |
| A-2 Troubleshooting for compressor system (Air is not cooled)..... | 80-71 |
| A-3 Troubleshooting for blower motor system (Air does not come out or air flow is abnormal)..... | 80-74 |
| A-4 Troubleshooting for FRESH/RECIRC air changeover..... | 80-76 |
| Troubleshooting with gauge pressure..... | 80-78 |
| Connection of service tool..... | 80-81 |
| Precautions for disconnecting and connecting air conditioner piping..... | 80-82 |
| Handling of compressor oil..... | 80-84 |
| 90 Diagrams and drawings..... | 90-2 |
| Hydraulic circuit diagram..... | 90-3 |
| Symbols in hydraulic circuit diagram..... | 90-3 |
| Power train hydraulic circuit diagram..... | 90-7 |
| Hydraulic circuit diagram..... | 90-9 |
| Electric circuit diagram..... | 90-21 |
| Symbols in electric circuit diagram..... | 90-21 |
| Electric circuit diagram..... | 90-25 |
| Electric circuit diagram for air conditioner unit..... | 90-51 |
| Index..... | 1 |

Foreword, safety and general information

Important safety notice

(Rev. 2011/02)

- Appropriate servicing and repair are extremely important to ensure safe operation of the machine. The Shop Manual describes the effective and safe servicing and repair methods recommended by Komatsu. Some of these methods require the use of special tools designed by Komatsu for the specific purpose.
- The symbol mark  is used for such matters that require special precautions during the work. The work indicated with the warning mark should be performed according to the instructions with special attention to the precautions. Should a hazardous situation occur or be anticipated during such work, be sure to keep safe first and take every necessary measure.

General precautions

 **Inappropriate handling creates an extreme danger. Read and understand what is described in the Operation and Maintenance Manual before operating the machine. In addition read this manual carefully and understand its contents before starting work.**

- Before performing any greasing or repairs, read all the safety labels stuck to the machine. For the locations of the safety labels and detailed explanation of precautions, see the Operation and Maintenance Manual.
- Locate a place in the repair workshop to keep tools and removed parts. Always keep the tools and parts in their correct places. Always keep the work area clean and make sure that there is no dirt, water, or oil on the floor. Smoke only in the areas provided for smoking. Never smoke while working.
- When performing any work, always wear safety shoes and helmet. Do not wear loose work clothes, or clothes with buttons missing.
 1. Always wear the protective eyeglasses when hitting parts with a hammer.
 2. Always wear the protective eyeglasses when grinding parts with a grinder, etc.
- When performing any work with two or more workers, always agree on the operating procedure before starting. Always inform your fellow workers before starting any step of the work. During the work, hang UNDER REPAIR warning tag in the operator's compartment.
- Only qualified workers must perform the work and operation which require license or qualification.
- Keep all tools in good condition. Learn the correct way to use them, and use the proper ones of them. Before starting work, thoroughly check the tools, machine, forklift truck, service car, etc.
- If welding repairs are needed, always have a trained and experienced welder perform the work. When performing welding work, always

wear welding gloves, apron, shielding goggles, cap and other clothes suited for welding work.

- Before starting work, warm up your body thoroughly to start work under good condition.
- Avoid continuing work for long hours and take rests at proper intervals to keep your body in good condition. Take rests in specified safe places.

Safety points

| | |
|----|--|
| 1 | Good arrangement |
| 2 | Correct work clothes |
| 3 | Following work standard |
| 4 | Making and checking signals |
| 5 | Prohibition of operation and handling by unlicensed workers |
| 6 | Safety check before starting work |
| 7 | Wearing protective goggles (for cleaning or grinding work) |
| 8 | Wearing shielding goggles and protectors (for welding work) |
| 9 | Good physical condition and preparation |
| 10 | Precautions against work which you are not used to or you are used to too much |

Preparation work

- Before adding oil or making any repairs, park the machine on a hard and level ground, and apply the parking brake and chock the wheels or tracks to prevent the machine from moving.
- Before starting work, lower the work equipment (blade, ripper, bucket, etc.) to the ground. If this is not possible, insert the lock pin or use blocks to prevent the work equipment from falling. In addition, be sure to lock all the control levers and hang warning tag on them.
- When disassembling or assembling, support the machine with blocks, jacks, or stands before starting the work.
- Remove all mud and oil from the steps or other places used to get on and off the machine. Always use the handrails, ladders or steps when getting on or off the machine. Never jump on or off the machine. When a scaffolding is not

provided, use steps or a step ladder to secure your footing.

Precautions during work

- For the machine equipped with a battery disconnect switch, before starting the work, check that the system operating lamp is turned OFF, and then turn the battery disconnect switch to the OFF (○) position and pull the switch key out. For machines without a battery disconnect switch, before starting the work, remove the cables from the battery. Always remove the cable from the negative (–) terminal first.
- Before disconnecting or removing components of the oil, water, or air circuits, first release the remaining pressure completely from the circuit. When removing the oil filter cap, a drain plug, or an oil pressure pickup plug, loosen it slowly to prevent the oil from spurting out.
- The coolant and oil in the circuits are hot when the engine is shut down. Be careful not to get scalded. Wait for the oil and coolant to cool before performing any work on the oil or water circuits.
- Before starting work, shut down the engine. When working on or around a rotating part, in particular, shut down the engine. When checking the machine without stopping the engine (measuring oil pressure, revolving speed, temperature, etc.), take extreme care not to get rolled or caught in rotating parts or moving parts.
- When raising a heavy component (heavier than 25 kg), use a hoist or crane. Before starting work, check that the slings (wire ropes, chains, and hooks) are free from damage. Always use slings which have ample capacity and install them to proper places. Operate the hoist or crane slowly to prevent the component from hitting any other part. Do not work with any part still raised by the hoist or crane.
- When removing a cover which is under internal pressure or under reaction force of a spring, always leave two bolts in diagonal positions. Loosen those two bolts gradually and alternately to release the pressure, and then remove the cover.
- When removing components, be careful not to break or damage the electrical wiring. Damaged wiring may cause electrical fires.
- When removing piping, stop the fuel or oil from spilling out. If any fuel or oil drips onto the floor, wipe it off immediately. Fuel or oil on the floor can cause you to slip and can even cause fires.
- As a general rule, do not use gasoline to wash parts. Do not use it to clean electrical parts, in particular.
- Be sure to assemble all parts again in their original places. Replace any damaged parts and parts which must not be reused with new parts.

When installing hoses and wires, be sure that they will not be damaged by contact with other parts when the machine is operated.

- When installing high pressure hoses and tubes, make sure that they are not twisted. Damaged hoses and tubes are dangerous, so be extremely careful when installing hoses and tubes for high-pressure circuits. In addition, check that connections of them are correct.
- When assembling or installing parts, always tighten them to the specified torques. When installing protective parts such as guards, or parts which vibrate violently or rotate at high speeds, be particularly careful to check that they are installed correctly.
- When aligning two holes, never insert your fingers or hand. Be careful not to get your fingers caught in a hole.
- When measuring hydraulic pressure, check that the measuring tools are correctly installed.
- Take care when removing or installing the tracks of track-type machines. When removing the track, the track separates suddenly, so never let anyone stand at either end of the track.
- If the engine is operated for a long time in a place which is not ventilated well, you may suffer from gas poisoning. Accordingly, open the windows and doors to ventilate well.

Precautions for slinging work and making signals

- Only one appointed worker must make signals and co-workers must communicate with each other frequently. The appointed signaler must make specified signals clearly at a place where he (she) is well seen from the operator's seat and where he (she) can see the working condition easily. The signaler must always stand in front of the load and guide the operator safely.
 1. Do not stand under the load.
 2. Do not step on the load.
- Check the slings before starting sling work.
- Keep putting on gloves during sling work. (Put on leather gloves, if available.)
- Measure the weight of the load by the eye and check its center of gravity.
- Use proper sling according to the weight of the load and method of slinging. If too thick wire ropes are used to sling a light load, the load may slip and fall.
- Do not sling a load with one wire rope alone. If it is slung by one wire rope, it may rotate and slip out of the rope. Install two or more wire ropes symmetrically.

 Slings with one rope may cause turning of the load during hoisting, untwisting of the rope, or slipping of the rope from its original

winding position on the load, which can result in a dangerous accident.

- Limit the hanging angle to 60 degrees, as a rule.
- Do not sling a heavy load (25 kg or more) with ropes forming a wide hanging angle from the hook.
- ★ When hoisting a load with two or more ropes, the force subjected to each rope will increase with the hanging angle. The figure below shows the variation of allowable load in kN {kg} when hoisting is made with two ropes, each of which is allowed to sling up to 9.8 kN {1,000 kg} vertically, at various hanging angles. When the two ropes sling a load vertically, up to 19.6 kN {2,000 kg} of total weight can be suspended. This weight is reduced to 9.8 kN {1,000 kg} when the two ropes make a hanging angle of 120 degrees. If the two ropes sling a 19.6 kN {2,000 kg} load at a lifting angle of 150 degrees, each rope is subjected to a force as large as 39.2 kN {4,000 kg}.

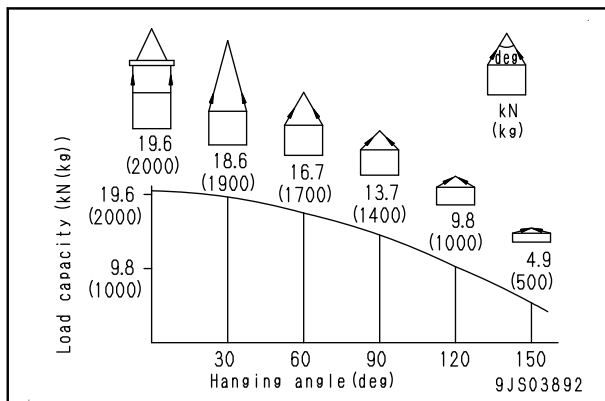

- When installing wire ropes to an angular load, apply pads to protect the wire ropes. If the load is slippery, apply proper material to prevent the wire rope from slipping.
- Use the specified eyebolts and fix wire ropes, chains, etc. to them with shackles, etc.
- Apply wire ropes to the middle portion of the hook.
- ★ Slings near the tip of the hook may cause the rope to slip off the hook during hoisting. The hook has the maximum strength at the middle part.

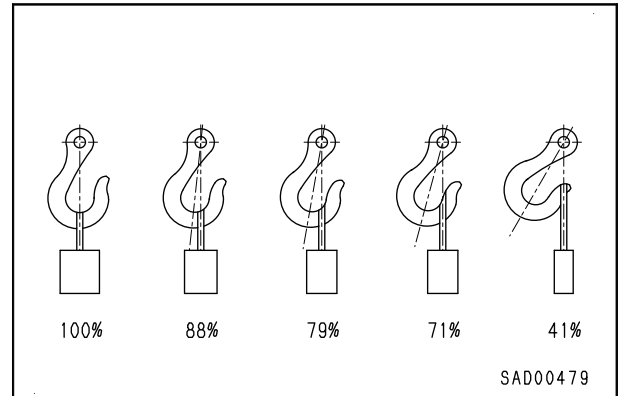

- Do not use twisted or kinked wire ropes.
- When lifting up a load, observe the following.
 1. Wind in the crane slowly until wire ropes are stretched. When settling the wire ropes with the hand, do not grasp them but press them from above. If you grasp them, your fingers may be caught.
 2. After the wire ropes are stretched, stop the crane and check the condition of the slung load, wire ropes, and pads.
 3. If the load is unstable or the wire rope or chains are twisted, lower the load and lift it up again.
 4. Do not lift up the load at an angle.
- When lowering a load, observe the following.
 1. When lifting down a load, stop it temporarily at 30 cm above the floor, and then lower it slowly.
 2. Check that the load is stable, and then remove the sling.
 3. Remove kinks and dirt from the wire ropes and chains used for the sling work, and put them in the specified place.

Precautions for using mobile crane

- ★ Read the Operation and Maintenance Manual of the crane carefully in advance and operate the crane safely.

Precautions for using overhead traveling crane

- ⚠ When raising a heavy part (heavier than 25 kg), use a hoist, etc. . In disassembly and assembly, the weight of a part heavier than 25 kg is indicated after the mark of .

- Before starting work, inspect the wire ropes, brake, clutch, controller, rails, over wind stop device, ground fault circuit interrupter, crane collision prevention device, and power application warning lamp, and check safety.
- Observe the signals for sling work.
- Operate the hoist at a safe place.
- Check the direction indicator plates (north, south, east, and west) and the directions of the control buttons without fail.

00 Index and foreword

Foreword, safety and general information

- Do not sling a load at an angle. Do not move the crane while the slung load is swinging.
- Do not raise or lower a load while the crane is moving longitudinally or laterally.
- Do not drag a sling.
- When lifting up a load, stop it just after it leaves the ground and check safety, and then lift it up.
- Consider the travel route in advance and lift up a load to a safe height.
- Place the control switch in a position where it will not be an obstacle to work and passage.
- After operating the hoist, do not swing the control switch.
- Remember the position of the main switch so that you can turn off the power immediately in an emergency.
- If the hoist stops because of a power failure, turn the power switch OFF. When turning on a switch which was turned OFF by the ground fault circuit interrupter, check that the devices related to that switch are not in operating condition.
- If you find an obstacle around the hoist, stop the operation.
- After finishing the work, stop the hoist at the specified position and raise the hook to at least two meters above the floor. Do not leave the sling attached to the hook.

Selecting wire ropes

- Select adequate ropes depending on the weight of parts to be hoisted, referring to the table below

Wire ropes (standard "Z" twist ropes without galvanizing) (JIS G3525, No. 6, Type 6x37-A)

| Nominal diameter of rope | Allowable load | |
|--------------------------|----------------|------|
| | kN | ton |
| mm | | |
| 10 | 8.8 | 0.9 |
| 12 | 12.7 | 1.3 |
| 14 | 17.3 | 1.7 |
| 16 | 22.6 | 2.3 |
| 18 | 28.6 | 2.9 |
| 20 | 35.3 | 3.6 |
| 25 | 55.3 | 5.6 |
| 30 | 79.6 | 8.1 |
| 40 | 141.6 | 14.4 |
| 50 | 221.6 | 22.6 |
| 60 | 318.3 | 32.4 |

- ★ The allowable load is one-sixth of the breaking strength of the rope to be used (Safety coefficient: 6).

Precautions for disconnecting and connecting hoses and tubes in air conditioner circuit

Disconnection

⚠ Disconnection although the refrigerant (refrigerant gas: R134a) used on the machine's air conditioner is less destructive to the ozone layer for environmental friendliness, it is not allowed to be released into the atmosphere as is. Whenever disconnecting the air conditioner gas circuit, be sure to recover the refrigerant gas to reuse it.

- ★ Ask a qualified person for collection, and charge of the refrigerant (R134a).
- ★ Never release the refrigerant (R134a) to the atmosphere.

⚠ If refrigerant gas (R134a) gets in your eyes, you may lose your sight. And if it touches your skins, you may suffer from frostbite. Accordingly, put on protective eyeglasses, gloves and working suits with long sleeves while you are collecting or filling the refrigerant (R134a).

- When loosening the nuts fixing air conditioner hoses and tubes, be sure to use two wrenches; use one wrench to fix and use the other one to loosen the nut.

Connection

- When installing the air conditioner hoses and tubes, take care to prevent any dirt, dust or water from entering.
- When installing the air conditioner hoses and tubes, check that O-rings are fitted to their joints.
- Once an O-ring is used, it is deformed and deteriorated. Accordingly, do not reuse it.
- When removing O-rings, use a soft tool so that the piping will not be damaged.
- Check that there is no defect or deterioration on the O-ring.
- Apply compressor oil for refrigerant (R134a) to the O-ring.
 - ★ However, do not apply oil to the threads portion of a bolt, nut or union.

| Manufacturer | Part name |
|-----------------------|--------------------------------|
| DENSO | ND-OIL8 |
| VALEO THERMAL SYSTEMS | ZXL100PG (equivalent to PAG46) |
| SANDEN | SP-10 |

- When tightening nuts of the air conditioner hoses and tubes, be sure to use two wrenches. Use one wrench to fix and tighten the nut with

the other wrench to the specified torque (Use a torque wrench for tightening).

★ Example of fitting of O-ring

- An O-ring is fitted to every joint of hoses and tubes in the air conditioner circuit.

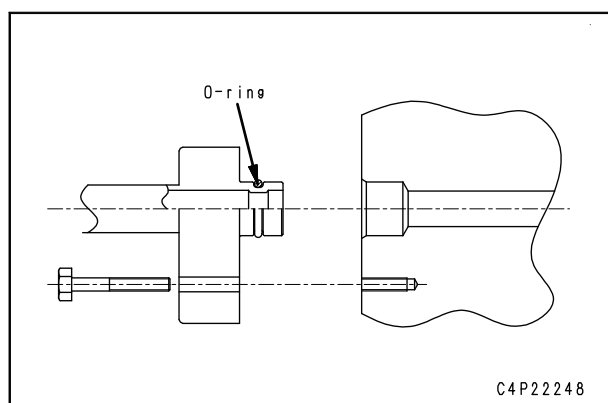
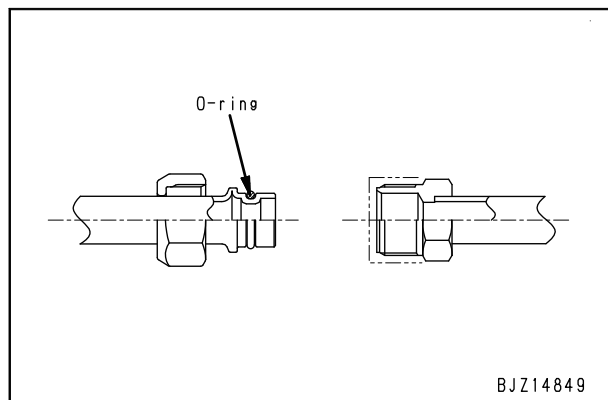

- ★ For tightening torques, see "Others", "Precautions for disconnection and connection of air conditioner piping".