

Operation & Maintenance Manual

SEAM008300

D375A-2

BULLDOZER

SERIAL NUMBERS D375A-16305 and up

WARNING

Unsafe use of this machine may cause serious injury or death. Operators and maintenance personnel must read this manual before operating or maintaining this machine. This manual should be kept near the machine for reference and periodically reviewed by all personnel who will come into contact with it.

NOTICE

Komatsu has Operation & Maintenance Manuals written in some other languages. If a foreign language manual is necessary, contact your local distributor for availability.

KOMATSU

This manual provides rules and guidelines which will help you use this machine safely and effectively. Keep this manual handy and have all personnel read it periodically. If this manual has been lost or has become dirty and can not be read, request a replacement manual from Komatsu or your Komatsu distributor.

If you sell the machine, be sure to give this manual to the new owners.

Continuing improvements in the design of this machine can lead to changes in detail which may not be reflected in this manual. Consult Komatsu or your Komatsu distributor for the latest available information of your machine or for questions regarding information in this manual.

This manual may contain attachments and optional equipment that are not available in your area. Consult Komatsu or your Komatsu distributor for those items you may require.

WARNING

- **Improper operation and maintenance of this machine can be hazardous and could result in serious injury or death.**
- **Operators and maintenance personnel should read this manual thoroughly before beginning operation or maintenance.**
Keep this manual in a readily available place near the machine, and have all personnel involved in working on the machine read the manual periodically.
- **Some actions involved in operation and maintenance of the machine can cause a serious accident, if they are not done in a manner described in this manual.**
- **The procedures and precautions given in this manual apply only to intended uses of the machine. If you use your machine for any unintended uses that are not specifically prohibited, you must be sure that it is safe for you and others. In no event should you or others engage in prohibited uses or actions as described in this manual.**
- **Komatsu delivers machines that comply with all applicable regulations and standards of the country to which it has been shipped. If this machine has been purchased in another country or purchased from someone in another country, it may lack certain safety devices and specifications that are necessary for use in your country. If there is any question about whether your product complies with the applicable standards and regulations of your country, consult Komatsu or your Komatsu distributor before operating the machine.**
- **The description of safety is given in SAFETY INFORMATION on page 0-2 and in SAFETY from page 1-1.**

2. SAFETY INFORMATION

Most accidents are caused by the failure to follow fundamental safety rules for the operation and maintenance of machines. To avoid accidents, read, understand and follow all precautions and warnings in this manual and on the machine before performing operation and maintenance.

To identify safety messages in this manual and on machine labels, the following signal words are used.

 **DANGER** - This word is used on safety messages and safety labels where there is a high probability of serious injury or death if the hazard is not avoided. These safety messages or labels usually describe precautions that must be taken to avoid the hazard. Failure to avoid this hazard may also result in serious damage to the machine.

 **WARNING** - This word is used on safety messages and safety labels where there is a potentially dangerous situation which could result in serious injury or death if the hazard is not avoided. These safety messages or labels usually describe precautions that must be taken to avoid the hazard. Failure to avoid this hazard may also result in serious damage to the machine.

 **CAUTION** - This word is used on safety messages and safety labels for hazards which could result in minor or moderate injury if the hazard is not avoided. This word might also be word for hazards where the only result could be damage to the machine.

NOTICE - This word is used for precautions that must be taken to avoid actions which could shorten the life of the machine.

Safety precautions are described in SAFETY from page 1-1.

Komatsu cannot predict every circumstance that might involve a potential hazard in operation and maintenance. Therefore the safety messages in this manual and on the machine may not include all possible safety precautions. If any procedures or actions not specifically recommended or allowed in this manual are used, you must be sure that you and others can do such procedures and actions safely and without damaging the machine. If you are unsure about the safety of some procedures, contact your Komatsu distributor.

3. INTRODUCTION

3.1 INTENDED USE

This Komatsu BULLDOZER is designed to be used mainly for the following work.

- Dozing
- Cutting into hard or frozen ground or ditching
- Felling trees, removing stumps
- Pushing
- Ripping

See the section "12.16 WORK POSSIBLE USING BULL DOZER" for further details.

3.2 FEATURES

- Increase in production through use of lock-up torque converter
- Big increase in durability of undercarriage
- Reduction in fuel costs and undercarriage costs through use of mode selection system
- Simplification of inspection and maintenance through use of monitoring system and centralization of maintenance on one side
- Improvement in operator comfort through use of large cab

3.3 BREAKING IN THE MACHINE

NOTICE

Before operating the machine for the first time, check that there is coolant in the radiator. If the machine is delivered with no coolant in the radiator, flush the inside of the radiator thoroughly with tap water, then fill the radiator with coolant.

Your Komatsu machine has been thoroughly adjusted and tested before shipment.

However, operating the machine under severe conditions at the beginning can adversely affect the performance and shorten the machine life.

Be sure to break in the machine for the initial 100 hours (as indicated by the service meter.)

During breaking in:

- Idle the engine for 5 minutes after starting it up.
- Avoid operation with heavy loads or at high speeds.
- Avoid sudden starts, sudden acceleration, sudden steering and sudden stops except in cases of emergency.

The precautions given in this manual for operating, maintenance, and safety procedures are only those that apply when this product is used for the specified purpose. If the machine is used for a purpose that is not listed in this manual, Komatsu cannot bear any responsibility for safety. All consideration of safety in such operations is the responsibility of the user.

Operations that are prohibited in this manual must never be carried out under any circumstances.

4. LOCATION OF PLATES, TABLE TO ENTER SERIAL NO. AND DISTRIBUTOR

4.1 MACHINE SERIAL NO. PLATE POSITION

Under the front of the console box on the right side of the operator's seat.

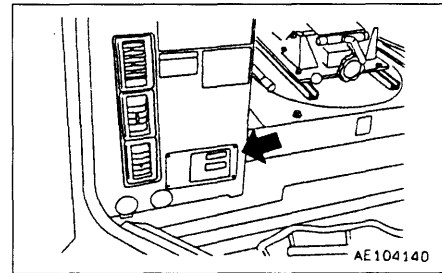

4.2 ENGINE SERIAL NO. PLATE POSITION

On the upper left side of the engine cylinder block, when seen from the fan.

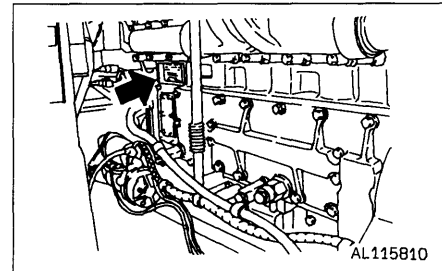

4.3 BLADE SERIAL NO. PLATE POSITION

This is located at the right side of blade back surface.

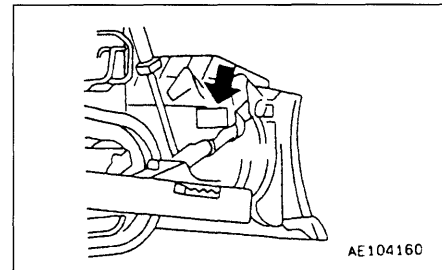

4.4 RIPPER SERIAL NO. PLATE POSITION

This is located at the left side surface of ripper beam.

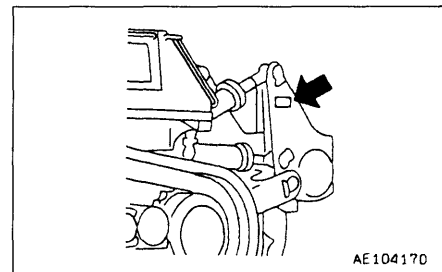

4.5 TABLE TO ENTER SERIAL NO. AND DISTRIBUTOR

Machine serial No.:	
Engine serial No.:	
Distributor name:	
Address:	Phone:
Service personnel for your machine:	

REMARKS

5. CONTENTS

1. Foreword	0- 1
2. Safety information	0- 2
3. Introduction	0- 3
4. Location of plates, table to enter serial No. and distributor	0- 4

SAFETY

6. General precautions	1- 2
7. Precautions during operation	1- 8
7.1 Before starting engine	1- 8
7.2 Operating machine	1-10
7.3 Transportation	1-13
7.4 Battery	1-14
7.5 Towing	1-15
8. Precautions for maintenance	1-16
8.1 Before carrying out maintenance	1-16
8.2 During maintenance	1-18
9. Position for attaching safety labels	1-23
9.1 Position for attaching safety labels	1-23
9.2 Content and use of warning plates	1-26

OPERATION

10. General view	2- 2
10.1 General view of machine	2- 2
10.2 General view of controls and gauges	2- 3
11. Explanation of components	2- 4
11.1 Monitor panel	2- 4
11.2 Lamps	2-14
11.3 Switches	2-15
11.4 Control levers and pedals	2-17
11.5 Dust indicator	2-22
11.6 Fuse box	2-22
11.7 Connector for additional lamp	2-24
11.8 Door lock	2-24
11.9 Car stereo	2-25
11.10 Operating the air conditioner	2-31

12. Operation	2-37
12.1 Check before starting engine	2-37
12.2 Starting engine	2-50
12.3 Operations and checks after starting engine	2-55
12.4 Moving machine	2-56
12.5 Shifting gear	2-57
12.6 Shifting between forward and reverse	2-58
12.7 Steering machine	2-59
12.8 Stopping machine	2-61
12.9 Precautions for operation	2-62
12.10 Work possible using bulldozer	2-64
12.11 Ripper operation	2-65
12.12 Adjustment of work equipment	2-68
12.13 Parking machine	2-71
12.14 Check after finishing work	2-72
12.15 Stopping engine	2-73
12.16 Check after stopping engine	2-74
12.17 Locking	2-74
12.18 Tips longer undercarriage life	2-75
13. Transportation	2-77
13.1 Loading, unloading work	2-77
13.2 Precautions for loading	2-78
13.3 Lifting position	2-78
13.4 Precautions for transportation	2-79
13.5 Removal of cab	2-79
14. Cold weather operation	2-82
14.1 Precautions for low temperature	2-82
14.2 After completion of work	2-84
14.3 After cold weather	2-84
15. Long-term storage	2-85
15.1 Before storage	2-85
15.2 During storage	2-85
15.3 After storage	2-86
16. Troubleshooting	2-87
16.1 After running out of fuel	2-87
16.2 Method of towing machine	2-87
16.3 If battery is discharged	2-87
16.4 Other trouble	2-90

MAINTENANCE

17. Guides to maintenance	3- 2
18. Outlines of service	3- 5
18.1 Outline of oil, fuel, coolant	3- 5
18.2 Relating to electric system	3- 7
19. Wear parts list	3- 8
20. Use of fuel, coolant and lubricants according to ambient temperature	3- 9
21. Standard tightening torques for bolts and nuts	3-13
21.1 Introduction of necessary tools	3-13
21.2 Torque list	3-14
22. Periodic replacement of safety critical parts	3-15
23. Maintenance schedule chart	3-18
24. Service Procedure	3-21
24.1 Initial 250 hours service	3-21
24.2 When required	3-22
24.3 Check before starting	3-38
24.4 Every 250 hours service	3-45
24.5 Every 500 hours service	3-53
24.6 Every 1000 hours service	3-56
24.7 Every 2000 hours service	3-60
24.8 Every 4000 hours service	3-65

SPECIFICATIONS

25. Specifications	4- 2
---------------------------------	------

OPTIONS, ATTACHMENTS

26. General precautions	5- 2
26.1 Precautions related to safety	5- 2
27. Using seat belt	5- 3
27.1 Fasten the belt and remove it in the following manner	5- 3
28. SELECTION OF TRACK SHOE	5- 4
28.1 Selection of track shoe	5- 4
29. Procedure for selecting ripper point	5- 5
29.1 Procedure for selecting ripper point	5- 5
30. Handling cap with lock	5- 6
30.1 Opening and closing lockable cap	5- 6

SAFETY

 **WARNING**

Read and follow all safety precautions. Failure to do so may result in serious injury or death.

This safety section also contains precautions for optional equipment and attachments.

6. GENERAL PRECAUTIONS

⚠ WARNING: For reasons of safety, always follow these safety precautions.

SAFETY RULES

- ONLY trained and authorized personnel can operate and maintain the machine.
- Follow all safety rules, precautions and instructions when operating or performing maintenance on the machine.
- When working with another operator or a person on worksite traffic duty, be sure all personnel understand all hand signals that are to be used.

SAFETY FEATURES

- Be sure all guards and covers are in their proper position. Have guards and covers repaired if damaged.
Proper position → See "12.1.1 WALK-AROUND CHECK".
- Use safety features such as the safety lock and seat belts properly.
- NEVER remove any safety features. ALWAYS keep them in good operating condition.
Safety lever → See "12.10 PARKING MACHINE".
Seat belts → See "27. USING SEAT BELT".
- Improper use of safety features could result in serious bodily injury or death.

CLOTHING AND PERSONAL PROTECTIVE ITEMS

- Avoid loose clothing, jewelry, and loose long hair. They can catch on controls or in moving parts and cause serious injury or death. Also, do not wear oily clothes because they are flammable.
- Wear a hard hat, safety glasses, safety shoes, mask or gloves when operating or maintaining the machine. Always wear safety goggles, hard hat and heavy gloves if your job involves scattering metal chips or minute materials - this is so particularly when driving pins with a hammer and when cleaning the air cleaner element with compressed air.
Check also that there is no one near the machine.
Cleaning of air cleaner element → See "24.2 WHEN REQUIRED" in service procedure.

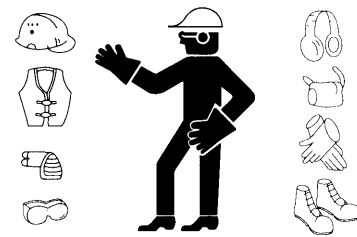

A0055010

UNAUTHORIZED MODIFICATION

- Any modification made without authorization from Komatsu can create hazards.
- Before making a modification, consult your Komatsu distributor. Komatsu will not be responsible for any injury or damage caused by any unauthorized modification.

STANDING UP FROM THE SEAT

To avoid hitting unlocked control levers, before standing up from operator's seat, do the following:

- Move gear shift lever to neutral and move SAFETY LEVER (located left of seat) to LOCK position.
- Lower work equipment to ground and move SAFETY LEVER (located right of seat) to LOCK position.
- Depress the brake pedal and move BRAKE LOCK LEVER (located right of seat) to LOCK position.

Sudden and unwanted machine movement can cause serious injury or death.

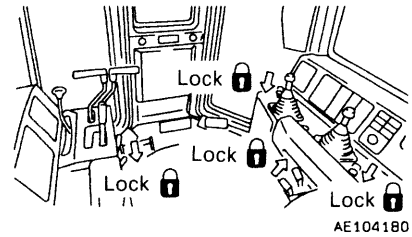

MOUNTING AND DISMOUNTING

- NEVER jump on or off the machine. NEVER get on or off a moving machine.
- When mounting and dismounting, face the machine and use the handholds and steps. Maintain three-point contact to be sure that you do not fall from the machine.
- Do not hold any control levers when getting on or off the machine.
- Repair any damaged handhold or step, and tighten any loose bolts. Handholds and steps must be free of oil, grease and excessive dirt.
- When mounting or dismounting, use the points marked with arrows in the diagram below.
- Use the parts marked by arrow A in the diagram below when getting on or off machine. Never use the parts marked by arrow B when getting on or off the machine. Use them only when moving along the top of the track or when checking or carrying out maintenance inside the side cover, or when filling the tank with oil.

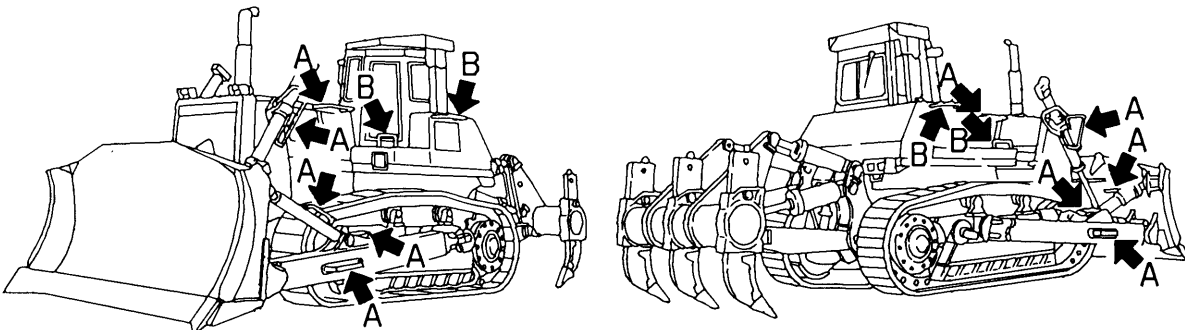

AL115820

FIRE PREVENTION FOR FUEL AND OIL

Fuel, oil, and antifreeze can be ignited by a flame. Fuel is particularly **FLAMMABLE** and can be **HAZARDOUS**.

- Keep a flame away from flammable fluids.
- Stop the engine and do not smoke when refueling.
- Tighten all fuel and oil caps securely.
- Refueling and oiling should be made in well ventilated areas.
- Keep oil and fuel in the determined place and do not allow unauthorized persons to enter.



A0055020



A0055030



A0055040

BURN HAZARD PREVENTION

- If the coolant, engine oil, power train oil or hydraulic oil is hot, use a heavy cloth, gloves, heavy clothing and safety glasses or goggles before checking or touching.
- To prevent hot water from spurting out:
 - 1) Turn engine off.
 - 2) Allow water to cool.
 - 3) Slowly loosen cap to relieve pressure before removing.
- To prevent hot oil from spurting out:
 - 1) Turn engine off.
 - 2) Allow oil to cool.
 - 3) Slowly loosen cap to relieve pressure before removing.

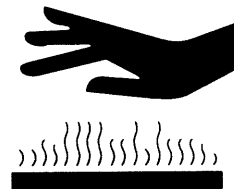

A0055050

ASBESTOS DUST HAZARD PREVENTION

- Asbestos dust can be HAZARDOUS to your health if it is inhaled.
- If you handle materials containing asbestos fibers, follow these guidelines as given below:
 - 1) NEVER use compressed air for cleaning.
 - 2) Use water for cleaning to minimize dust cloud.
 - 3) Operate the machine with the wind to your back, whenever possible.
 - 4) Use an approved respirator if necessary.



A0055060

CRUSHING OR CUTTING PREVENTION

- Do not enter, or put your hand or arm or any other part of your body between movable parts such as between the work equipment and cylinders, or between the machine and the blade or ripper or any other attachment.
- If the work equipment is operated, the clearance will change and this may lead to serious damage or personal injury.

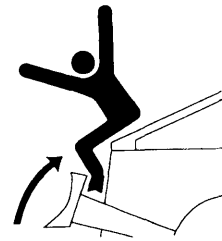

A0055230

FIRE EXTINGUISHER AND FIRST AID KIT

- Be sure fire extinguishers have been provided and know how to use them.
- Know where a first aid kit is located.
- Know what to do in the event of a fire.
- Be sure you know the phone numbers of persons you should contact in case of an emergency.

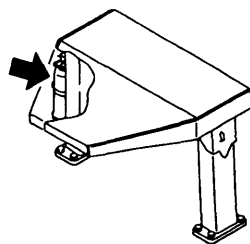

AE104200

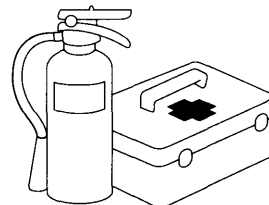

A0055070

PRECAUTIONS FOR ROPS

- Do not operate machine with ROPS removed if equipped.
- The ROPS is installed to protect the operator if the machine should overturn. It is designed not only to take the load when the machine overturns, but also to absorb the impact energy.
- The Komatsu ROPS fulfills all worldwide regulations and standards, but if any unauthorized modification is carried out on it, or if it is damaged when the machine overturns, its strength will be reduced and it will not be able to provide its original capacity. It will be able to provide this capacity only if modifications and repairs are carried out in the specified way.
- When carrying out modification or repairs, always consult your Komatsu distributor first.
- Even when the ROPS is installed, if you do not fasten your seat belt securely, it cannot protect you properly. Always fasten your seat belt when operating the machine.
Seat belts → See "27. USING SEAT BELT."

PRECAUTIONS FOR ATTACHMENTS

- When installing and using an optional attachment, read the instruction manual for the attachment and the information related to attachments in this manual.
- Do not use attachments that are not authorized by Komatsu or your Komatsu distributor. Use of unauthorized attachments could create a safety problem and adversely affect the proper operation and useful life of the machine.
- Any injuries, accidents, product failures resulting from the use of unauthorized attachments will not be the responsibility of Komatsu.

7. PRECAUTIONS DURING OPERATION

⚠ WARNING: For reasons of safety, always follow these safety precautions.

7.1 BEFORE STARTING ENGINE

SAFETY AT WORKSITE

- Before starting the engine, thoroughly check the area for any unusual conditions that could be dangerous.
- Before starting the engine, examine the terrain and soil conditions of the worksite. Determine the best and safest method of operation.
- If you need to operate on a street, protect pedestrians and cars by designating a person for worksite traffic duty or by installing fences around the worksite.
- If water lines, gas lines, and high-voltage electrical lines may be buried under the worksite, contact each utility and identify their locations. Be careful not to sever or cut any of these lines.
- Check the depth and flow of water before operating in water or crossing a river. NEVER be in water which is in excess of the permissible water depth.
Permissible water depth → See "12.9.1 PERMISSIBLE WATER DEPTH".

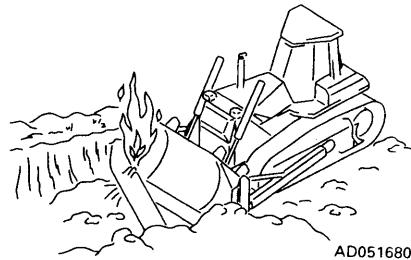

AD051680

FIRE PREVENTION

- Thoroughly remove wood chips, leaves, paper and other flammable things accumulated on the engine compartment. They could cause a fire.
- Check fuel, lubrication, and hydraulic systems for leaks. Have any leaks repaired. Wipe up any excess oil, fuel or other flammable fluids.
Check point → See "12.1.1 WALK-AROUND CHECK".
- Be sure a fire extinguisher is present and working.



A0055020

IN OPERATOR'S CAB

- Do not leave tools or spare parts lying around in the operator's compartment. They may damage or break the control levers on switches.
- Keep the cab floor, controls, steps and handholds free of oil, grease, snow, and excess dirt.
- Check the seat belt, buckle and hardware for damage or wear. Replace any worn or damaged parts. Always use seat belts when operating your machine.
Seat belts → See "27. USING SEAT BELT".

VENTILATION FOR ENCLOSED AREAS

- If it is necessary to start the engine within an enclosed area, provide adequate ventilation. Exhaust fumes from the engine can KILL.



A0055060

PRECAUTIONS FOR MIRRORS, WINDOWS AND LIGHTS

- Remove all dirt from the surface of the windows and lights to ensure that you can see well.
- Adjust the rear view mirror so that you can see clearly from the operator's seat, and always keep the surface of the mirror clean. If any glass is broken, replace it with a new part.
- Check that the head lamps and rear lamps are installed to match the operating conditions. Check also that they light up properly.

PRECAUTIONS FOR SLIDING GLASS INTERMEDIATE LOCK

The sliding glass intermediate lock is to prevent rattling of the glass. Even when the lock is used, the glass may move because of the shock when starting or stopping suddenly. Do not put your head or hands out of the window during operations.

CHECK THOROUGHLY BEFORE STARTING

Always carry out all checks before starting.

7.2 OPERATING MACHINE

WHEN STARTING ENGINE

- Walk around your machine again just before mounting it, checking for people and objects that might be in the way.
- NEVER start the engine if a warning tag has been attached to the control.
- When starting the engine, sound the horn as an alert.
- Start and operate the machine only while seated.
- Do not allow anyone other than the operator to ride in the cab or on the machine body.
- For machines equipped with backup alarm, check that the warning device operates correctly.

PRECAUTIONS WHEN MOVING FORWARD OR BACKWARD

Before moving machine or its attachments:

- Honk horn to alert people nearby.
- Be sure no one is around machine, particularly behind machine.
- Use spotter if necessary, particularly if you are moving in reverse.
- When operating in areas that may be hazardous or have poor visibility, designate a person to direct worksite traffic.
- Prevent people from entering the line of travel of the machine.

Follow above even if equipped with backup alarm and mirrors.

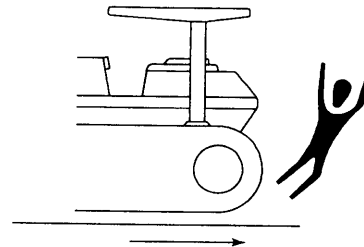

A0055080

TRAVELING ON SLOPES

- Traveling on hills, banks or slopes that are steep could result in the machine tipping over or slipping.
- On hills, banks or slopes, carry the work equipment closer to the ground, approximately 20 to 30 cm (8 to 12 in) above the ground. In case of emergency, quickly lower the work equipment to the ground to help the machine stop and prevent it from tipping over.
- Do not change direction on slopes. Avoid sideways travel whenever possible: rather travel up and down the slopes.
- Do not travel up and down on grass, fallen leaves, and wet steel plates. These materials may allow the machine to slip, if it is traveling sideways. Keep travel speed very low.
- When traveling downhill, drive slowly and use the engine as a brake.
- When traveling downhill with the machine being pushed by its own weight, the machine may steer in the opposite direction, so be careful when steering.
Reverse steering when traveling downhill → See "12.7.2 TURNING WHILE DESCENDING A SLOPE".

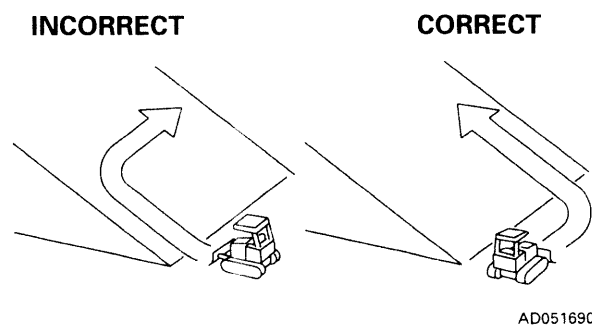

VISIBILITY

- Turn ON the head lamps and rear lamp, when working at night or at dark sites. Provide additional lights for the worksite if necessary.
- If visibility is diminished by fog, snow or rain, stop operation. Wait until there is adequate visibility for safe operation.

WORKING ON SNOWY SITE

- Snow-covered and frozen ground may allow the machine to slip sideways, even if the grade is not steep. Slow down the machine when traveling on such ground. Avoid rapid starts, stops, and steering.
- In snow removal work, pay special attention to the edge of the road and to objects under the snow.

WORKING ON LOOSE GROUND

- Avoid operating your machine too close to the edge of cliffs, overhangs, and deep ditches. If these areas collapse, your machine could fall or tip over and result in serious injury or death. Remember that the soil after heavy rain or blasting is weakened in these areas.
- Earth laid on the ground and the soil near ditches are loose. They can collapse under the weight or vibration of your machine.
- Install the HEAD GUARD or FOPS if working in areas where there is danger of falling rocks and dirt.
- When working in places where there is danger of falling rocks or danger of the machine turning over, install ROPS and a seat belt.

PARKING THE MACHINE

- Park on level ground whenever possible. If not possible, block the tracks, lower the blade to the ground and thrust the edge of the blade in the ground.

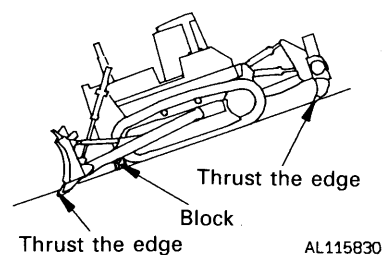

- When parking on public roads, provide fences and signs, such as flags or lights, on the machine to warn passersby to be careful. Be sure that the machine, flags or lights do not obstruct traffic.
Parking procedure → See "12.10 PARKING MACHINE".
- Before leaving the machine, lower the work equipment to the ground, move the SAFETY LEVER to LOCK position, stop the engine, and lock all the doors, windows, and covers and remove the key(s).
Work equipment posture → See "12.10 PARKING MACHINE".
Locks → See "12.14 LOCKING".