

Shop Manual

HYDRAULIC
EXCAVATOR

PC210LC-10

SERIAL NUMBERS 450001 and up

KOMATSU

SHOP MANUAL

HYDRAULIC EXCAVATOR

PC210LC-10

Model Serial Number

PC210LC-10 450001 and up

00 Index and foreword

00 Index and foreword

Index

Index (ALL-0310-001-A-00-A)

00 Index and foreword	00-1
Index	00-2
Foreword, safety and general information	00-14
Important safety notice	00-14
How to read the shop manual	00-21
Explanation of terms for maintenance standard	00-23
Handling equipment of fuel system devices	00-25
Handling of intake system parts	00-26
Handling of hydraulic equipment	00-27
Method of disconnecting and connecting of push-pull type coupler	00-29
Handling of electrical equipment	00-32
How to read electric wire code	00-40
Precautions when performing operation	00-43
Practical use of KOMTRAX	00-47
Standard tightening torque table	00-48
List of abbreviation	00-52
Conversion table	00-57
01 Specification	01-1
Table of contents	01-2
Specifications	01-3
Specification drawing	01-3
Working range drawings	01-4
Specifications	01-5
Weight table	01-8
Table of fuel, coolant, and lubricants	01-9
10 Structure and function	10-1
Table of contents	10-2
Engine and cooling system	10-3
Engine related parts	10-3
KVTG	10-5
EGR system piping drawing	10-12
EGR system circuit diagram	10-14
EGR valve	10-16
EGR cooler	10-18
KCCV layout drawing	10-19
KCCV ventilator	10-21
KDPF	10-23
Cooling system	10-27
Power train	10-29
Power train system	10-29
Swing circle	10-31
Swing machinery	10-32
Final drive	10-34
Undercarriage and frame	10-36
Track frame and idler cushion	10-36
Hydraulic system	10-38
Hydraulic equipment layout drawing	10-38
Valve control	10-40
Hydraulic tank	10-42
CLSS	10-44
Main pump	10-49
Control valve	10-74
Swing motor	10-131
Travel motor	10-143
PPC valve	10-156
Solenoid valve	10-178
Attachment circuit selector valve (for high pressure circuit)	10-181

Attachment circuit selector valve (for low pressure circuit).....	10-183
Center swivel joint.....	10-186
Accumulator.....	10-188
Work equipment.....	10-189
Work equipment.....	10-189
Work equipment shim.....	10-190
Bucket play adjustment shim.....	10-191
Cab and its attachments.....	10-192
Cab mount and cab tipping stopper.....	10-192
ROPS cab.....	10-193
Electrical system.....	10-194
Electrical control system.....	10-194
Machine monitor system.....	10-245
KOMTRAX system.....	10-267
Sensor.....	10-270
20 Standard value tables.....	20-1
Table of contents.....	20-2
Standard service value table.....	20-3
Standard value table for engine.....	20-3
Standard value table for machine.....	20-5
Standard value table for electrical system.....	20-18
30 Testing and adjusting.....	30-1
Table of contents.....	30-2
General information on testing and adjusting.....	30-3
Tools for testing and adjusting.....	30-3
Sketch of tools for testing and adjusting.....	30-7
Engine and cooling system.....	30-8
Testing engine speed.....	30-8
Testing boost pressure.....	30-9
Testing exhaust gas color.....	30-11
Measuring and adjusting valve clearance.....	30-13
Testing compression pressure.....	30-16
Testing blowby pressure.....	30-20
Testing engine oil pressure.....	30-21
Testing EGR valve and KVGT oil pressures.....	30-22
Measuring fuel pressure.....	30-23
Measuring fuel delivery, return and leakage.....	30-29
Bleeding air from fuel system.....	30-34
Checking fuel circuit for leakage.....	30-36
Handling cylinder cutout mode operation.....	30-37
Handling no injection cranking operation.....	30-38
Checking and adjusting air conditioner compressor belt tension.....	30-39
Replacing fan belt.....	30-41
Power train.....	30-42
Testing swing circle bearing clearance.....	30-42
Undercarriage and frame.....	30-43
Testing and adjusting track shoe tension.....	30-43
Hydraulic system.....	30-44
Releasing remaining pressure from hydraulic circuit.....	30-44
Testing and adjusting oil pressure in work equipment, swing, and travel circuits.....	30-45
Testing oil pressure of control circuit.....	30-49
Testing and adjusting oil pressure in pump PC control circuit.....	30-52
Testing and adjusting oil pressure in pump LS control circuit.....	30-55
Testing output pressure of solenoid valve.....	30-60
Testing PPC valve output pressure.....	30-64
Adjusting play of work equipment and swing PPC valves.....	30-66
Testing pump swash plate sensor.....	30-67
Isolating the parts causing hydraulic drift in work equipment.....	30-68
Testing oil leakage.....	30-69

Bleeding air from hydraulic circuit	30-72
Cab and its attachments	30-74
Checking cab tipping stopper	30-74
Adjusting mirrors	30-75
Electrical system	30-77
Special functions of machine monitor	30-77
Adjusting rearview camera angle	30-148
Handling voltage circuit of engine controller	30-150
Handling battery disconnect switch	30-151
Testing diodes	30-152
Pm clinic	30-153
Pm Clinic service	30-153
40 Troubleshooting	40-1
Table of contents	40-2
General information on troubleshooting	40-9
Troubleshooting points	40-9
Sequence of events in troubleshooting	40-11
Testing before troubleshooting	40-13
Inspection procedure before troubleshooting	40-15
Preparation work for troubleshooting of electrical system	40-34
Classification and procedure for troubleshooting	40-38
Symptom of probable failure and troubleshooting No.	40-41
Information in troubleshooting table	40-44
Diagnostic procedure for wiring harness open circuit of pressure sensor system	40-46
Connector list and layout	40-48
Connector contact identification	40-59
T-branch box and T-branch adapter table	40-95
Fuse location table	40-101
Precautions for KDPF (KCSF and KDOC) Cleaning and Replacement	40-103
Fabrication of dummy temperature sensor (for KDOC and KDPF temperature sensors)	40-106
Fabrication of short-circuit connector (for CA1883 and CA3135)	40-107
Failure codes table	40-108
Troubleshooting by failure code (Display of code)	40-117
Failure code [879AKA] A/C Inner Sensor Open Circuit	40-117
Failure code [879AKB] A/C Inner Sensor Short Circuit	40-118
Failure code [879BKA] A/C Outer Sensor Open Circuit	40-119
Failure code [879BKB] A/C Outer Sensor Short Circuit	40-120
Failure code [879CKA] Ventilating Sensor Open Circuit	40-121
Failure code [879CKB] Ventilating Sensor Short Circuit	40-122
Failure code [879DKZ] Sunlight Sensor Open or Short Circuit	40-123
Failure code [879EMC] Ventilation Damper Abnormality	40-124
Failure code [879FMC] Air Mix Damper Abnormality	40-125
Failure code [879GKX] Refrigerant Abnormality	40-126
Failure code [989L00] Engine Controller Lock Caution1	40-127
Failure code [989M00] Engine Controller Lock Caution2	40-128
Failure code [989N00] Engine Controller Lock Caution3	40-129
Failure code [A1U0N3]: KDPF Dry Request (HC Release)	40-130
Failure code [A1U0N4] KDPF Dry Request (HC Release)	40-132
Failure code [AA10NX] Air Cleaner Clogging	40-134
Failure code [AB00KE] Charge Voltage Low	40-136
Failure code [B@BAZG] Engine Oil Pressure Low	40-138
Failure code [B@BAZK] Eng Oil Level Low	40-139
Failure code [B@BCNS] Engine Coolant Overheat	40-140
Failure code [B@BCZK] Radiator Coolant Level Low	40-141
Failure code [B@HANS] Hyd Oil Overheat	40-143
Failure code [CA115] Eng Ne and Bkup Speed Sens Error	40-144
Failure code [CA122] Chg Air Press Sensor High Error	40-145
Failure code [CA123] Chg Air Press Sensor Low Error	40-147

Failure code [CA131] Throttle Sensor High Error.....	40-149
Failure code [CA132] Throttle Sensor Low Error	40-151
Failure code [CA144] Coolant Temp Sens High Error	40-153
Failure code [CA145] Coolant Temp Sens Low Error	40-155
Failure code [CA153] Chg Air Temp Sensor High Error	40-157
Failure code [CA154] Chg Air Temp Sensor Low Error.....	40-159
Failure code [CA187] Sensor 2 Supply Volt Low Error	40-161
Failure code [CA221] Ambient Press Sens High Error	40-163
Failure code [CA222] Ambient Press Sens Low Error	40-165
Failure code [CA227] Sensor 2 Supply Volt High Error.....	40-167
Failure code [CA234] Eng Overspeed	40-168
Failure code [CA238] Ne Speed Sensor Supply Volt Error	40-169
Failure code [CA239] Ne Speed Sens Supply Volt High Error.....	40-170
Failure code [CA271] IMV/PCV1 Short Error	40-171
Failure code [CA272] IMV/PCV1 Open Error	40-173
Failure code [CA295] Ambient Press Sens In Range Error.....	40-175
Failure code [CA322] Inj #1(L#1) Open/Short Error	40-176
Failure code [CA323] Inj #5(L#5) Open/Short Error	40-178
Failure code [CA324] Inj #3(L#3) Open/Short Error	40-180
Failure code [CA325] Inj #6(L#6) Open/Short Error	40-182
Failure code [CA331] Inj #2(L#2) Open/Short Error	40-184
Failure code [CA332] Inj #4(L#4) Open/Short Error	40-186
Failure code [CA343] ECM Critical Internal Failure	40-188
Failure code [CA351] Injectors Drive Circuit Error	40-189
Failure code [CA352] Sensor 1 Supply Volt Low Error	40-190
Failure code [CA356] Mass Air Flow Sensor High Error	40-192
Failure code [CA357] Mass Air Flow Sensor Low Error	40-194
Failure code [CA386] Sensor 1 Supply Volt High Error.....	40-196
Failure code [CA428] Water in Fuel Sensor High Error	40-197
Failure code [CA429] Water in Fuel Sensor Low Error	40-199
Failure code [CA435] Eng Oil Press Sw Error	40-201
Failure code [CA441] Battery Voltage Low Error	40-202
Failure code [CA442] Battery Voltage High Error.....	40-204
Failure code [CA449] Rail Press Very High Error.....	40-205
Failure code [CA451] Rail Press Sensor High Error.....	40-206
Failure code [CA452] Rail Press Sensor Low Error	40-208
Failure code [CA488] Chg Air Temp High Torque Derate	40-210
Failure code [CA515] Rail Press Sens Sup Volt High Error	40-211
Failure code [CA516] Rail Press Sens Sup Volt Low Error	40-213
Failure code [CA553] Rail Press High Error	40-215
Failure code [CA555] Crankcase Press High Error 1	40-216
Failure code [CA556] Crankcase Press High Error 2	40-217
Failure code [CA559] Rail Press Low Error.....	40-218
Failure code [CA595] Turbo Speed High Error 2	40-220
Failure code [CA687] Turbo Speed Low Error.....	40-221
Failure code [CA689] Eng Ne Speed Sensor Error.....	40-223
Failure code [CA691] Intake Air Temp Sens High Error.....	40-225
Failure code [CA692] Intake Air Temp Sens Low Error.....	40-227
Failure code [CA697] ECM Int Temp Sensor High Error	40-229
Failure code [CA698] ECM Int Temp Sensor Low Error.....	40-230
Failure code [CA731] Eng Bkup Speed Sens Phase Error	40-231
Failure code [CA778] Eng Bkup Speed Sensor Error.....	40-233
Failure code [CA1117] Persistent Data Lost Error.....	40-238
Failure code [CA1664] KDOC Malfunction.....	40-239
Failure code [CA1691] Regeneration Ineffective	40-241
Failure code [CA1695] Sensor 5 Supply Volt High Error.....	40-244
Failure code [CA1696] Sensor 5 Supply Volt Low Error	40-246
Failure code [CA1843] Crankcase Press Sens High Error.....	40-248
Failure code [CA1844] Crankcase Press Sens Low Error	40-250

Failure code [CA1879] KDPF Delta P Sensor High Error	40-252
Failure code [CA1881] KDPF Delta P Sensor Low Error	40-254
Failure code [CA1883] KDPF Delta P Sens In Range Error	40-256
Failure code [CA1921] KDPF Soot Load High Error 1	40-259
Failure code [CA1922] KDPF Soot Load High Error 2	40-262
Failure code [CA1942] Crankcase Press Sens In Range Error	40-267
Failure code [CA1993] KDPF Delta Pressure Low Error	40-268
Failure code [CA2185] Throt Sensor Sup Volt High Error	40-271
Failure code [CA2186] Throt Sensor Sup Volt Low Error	40-273
Failure code [CA2249] Rail Press Very Low Error	40-275
Failure code [CA2271] EGR Valve Pos Sens High Error	40-276
Failure code [CA2272] EGR Valve Pos Sens Low Error	40-278
Failure code [CA2288] Turbo Speed High Error 1	40-281
Failure code [CA2311] IMV Solenoid Error	40-282
Failure code [CA2349] EGR Valve Solenoid Open Error	40-283
Failure code [CA2353] EGR Valve Solenoid Short Error	40-285
Failure code [CA2357] EGR Valve Servo Error	40-287
Failure code [CA2373] Exhaust Manifold Press Sens High error	40-288
Failure code [CA2374] Exhaust Manifold Press Sens Low error	40-290
Failure code [CA2375] EGR Orifice Temp Sens High Error	40-292
Failure code [CA2376] EGR Orifice Temp Sens Low Error	40-294
Failure code [CA2381] KVGTT Pos Sens High Error	40-296
Failure code [CA2382] KVGTT Pos Sens Low Error	40-298
Failure code [CA2383] KVGTT Solenoid Open Error	40-301
Failure code [CA2386] KVGTT Solenoid Short Error	40-303
Failure code [CA2387] KVGTT Servo Error	40-305
Failure code [CA2554] Exh Manifold Press Sens In Range Error	40-306
Failure code [CA2555] Grid Htr Relay Volt Low Error	40-307
Failure code [CA2556] Grid Htr Relay Volt High Error	40-309
Failure code [CA2637] KDOC Face Plugging	40-311
Failure code [CA2639] Manual Stationary Regeneration Request	40-313
Failure code [CA2961] EGR Orifice Temp High Error 1	40-316
Failure code [CA2973] Chg Air Press Sensor In Range Error	40-317
Failure code [CA3133] KDPF Outlet Press Sens High Error	40-318
Failure code [CA3134] KDPF Outlet Press Sens Low Error	40-320
Failure code [CA3135] KDPF Outlet Press Sens In Range Error	40-322
Failure code [CA3251] KDOC Inlet Temp High Error	40-326
Failure code [CA3253] KDOC Temp Error - Non Regeneration	40-329
Failure code [CA3254] KDOC Outlet Temp High Error 1	40-332
Failure code [CA3255] KDPF Temp Error - Non Regeneration	40-335
Failure code [CA3256] KDPF Outlet Temp High Error 1	40-338
Failure code [CA3311] KDOC Outlet Temp High Error 2	40-341
Failure code [CA3312] KDPF Outlet Temp High Error 2	40-344
Failure code [CA3313] KDOC Inlet Temp Sensor Low Error	40-347
Failure code [CA3314] KDOC Inlet Temp Sens High Error	40-350
Failure code [CA3315] KDOC Inlet Temp Sens In Range Error	40-353
Failure code [CA3316] KDOC Outlet Temp Sens Low Error	40-357
Failure code [CA3317] KDOC Outlet Temp Sens High Error	40-360
Failure code [CA3318] KDOC Outlet Temp Sens In Range Error	40-364
Failure code [CA3319] KDPF Outlet Temp Sens High Error	40-368
Failure code [CA3321] KDPF Outlet Temp Sens Low Error	40-372
Failure code [CA3322] KDPF Outlet Temp Sens In Range Error	40-375
Failure code [CA3419] Mass Air Flow Sensor Sup Volt High Error	40-379
Failure code [CA3421] Mass Air Flow Sensor Sup Volt Low Error	40-381
Failure code [CA3741] Rail Press Valve Trip Error	40-383
Failure code [D110KB] Battery Relay Output Voltage	40-384
Failure code [D19JKZ] Personal Code Relay Abnormality	40-386
Failure code [D811MC] KOMTRAX Error	40-389
Failure code [D862KA] GPS Antenna Open Circuit	40-390

Failure code [D8ALKA] System Operating Lamp Disconnection (KOMTRAX).....	40-391
Failure code [D8ALKB] System Operating Lamp Short Circuit (KOMTRAX)	40-393
Failure code [D8AQKR] CAN2 Discon (KOMTRAX)	40-394
Failure code [DA20MC] Pump Controller.....	40-395
Failure code [DA22KK] Pump Solenoid Power Low Error.....	40-396
Failure code [DA25KP] 5V Sensor 1 Power Abnormality.....	40-398
Failure code [DA29KQ] Model Selection Abnormality	40-401
Failure code [DA2LKA] System Operating Lamp Disconnection (Pump Con)	40-403
Failure code [DA2LKB] System Operating Lamp Short Circuit (Pump Con)	40-405
Failure code [DA2QKR] CAN2 Discon (Pump Con).....	40-406
Failure code [DA2RKR] CAN1 Discon (Pump Con).....	40-409
Failure code [DAF0MB] Monitor ROM Abnormality.....	40-410
Failure code [DAF0MC] Monitor Error	40-411
Failure code [DAF8KB] Camera Power Supply Short Circuit	40-412
Failure code [DAF9KQ] Model Selection Abnormality	40-414
Failure code [DAFGMC] GPS Module Error.....	40-415
Failure code [DAFLKA] Operating Lamp Open Circuit(Monitor)	40-416
Failure code [DAFLKB] System Operating Lamp Short Circuit (Monitor).....	40-418
Failure code [DAFQKR] CAN2 Discon (Monitor)	40-419
Failure code [DAZ9KQ] A/C Model Selection Abnormality.....	40-420
Failure code [DAZQKR] CAN2 Discon (AC).....	40-421
Failure code [DB2QKR] CAN2 Discon (Engine Con)	40-426
Failure code [DB2RKR] CAN1 Discon (Engine Con)	40-431
Failure code [DGH2KB] Hyd Oil Sensor Short	40-435
Failure code [DHA4KA] Air Cleaner Clog Sensor Open Circuit	40-437
Failure code [DHPAMA] F Pump Press Sensor Abnormality.....	40-438
Failure code [DHPBMA] R Pump Press Sensor Abnormality	40-441
Failure code [DHS3MA] Arm IN PPC Sen. Abnormality	40-444
Failure code [DHS4MA] Bucket Curl PPC Press Sensor Abnormality	40-446
Failure code [DHS8MA] Boom Raise PPC Press Sensor Abnormality.....	40-449
Failure code [DHS9MA] Boom LOWER Press Sensor Abnormality.....	40-452
Failure code [DHSAMA] Swing RH PPC Press Sensor Abnormality	40-455
Failure code [DHSBMA] Swing LH PPC Press Sensor Abnormality	40-458
Failure code [DHSCMA] Arm Dump PPC Press Sensor Abnormality	40-461
Failure code [DHSDMA] Bucket Dump PPC Press Sensor Abnormality	40-464
Failure code [DHSFMA] Travel Fwd LH PPC Press Sensor Abnormality	40-467
Failure code [DHSGMA] Travel Fwd RH PPC Press Sensor Abnormality	40-470
Failure code [DHSHMA] Travel Rev LH PPC Press Sensor Abnormality	40-473
Failure code [DHSJMA] Travel Rev RH PPC Press Sensor Abnormality	40-476
Failure code [DKR0MA] F pump S/P sensor Abnormality.....	40-479
Failure code [DKR1MA] R pump S/P sensor Abnormality	40-481
Failure code [DR21KX] Camera 2 Picture Rev. Drive Abnormality	40-483
Failure code [DR31KX] Camera 3 Picture Rev. Drive Abnormality	40-485
Failure code [DV20KB] Travel Alarm Short Circuit.....	40-487
Failure code [DW43KA] Travel Speed Sol Open Circuit	40-489
Failure code [DW43KB] Travel Speed Sol Short Circuit	40-491
Failure code [DW45KA] Swing holding brake Sol Open Circuit.....	40-493
Failure code [DW45KB] Swing holding brake Sol Short Circuit	40-496
Failure code [DW91KA] Travel Junction Sol Open Circuit	40-499
Failure code [DW91KB] Travel Junction Sol Short Circuit.....	40-501
Failure code [DWA2KA] Attachment Sol Open Circuit.....	40-503
Failure code [DWA2KB] Attachment Sol Short Circuit.....	40-505
Failure code [DWK0KA] 2-Stage Relief Sol Open Circuit	40-507
Failure code [DWK0KB] 2-stage Relief Sol Short Circuit	40-509
Failure code [DWK2KA] Variable Back Press Sol Open Circuit.....	40-511
Failure code [DWK2KB] Variable Back Press Sol Short Circuit.....	40-513
Failure code [DWK8KA] Swing Press C/O Sol Open Circuit	40-515
Failure code [DWK8KB] Swing Press C/O Sol Short Circuit	40-517
Failure code [DXA8KA] PC-EPC (F) Sol Open Circuit.....	40-519

Failure code [DXA8KB] PC-EPC (F) Sol Short Circuit.....	40-521
Failure code [DXA9KA] PC-EPC (R) Sol Open Circuit	40-523
Failure code [DXA9KB] PC-EPC (R) Sol Short Circuit	40-525
Failure code [DXE0KA] LS-EPC Sol Open Circuit	40-527
Failure code [DXE0KB] LS-EPC Sol Short Circuit	40-529
Failure code [DXE4KA] Attachment Flow EPC Open Circuit	40-531
Failure code [DXE4KB] Attachment Flow EPC Short Circuit.....	40-533
Failure code [DXE5KA] Merge-divide Main Sol Open Circuit	40-535
Failure code [DXE5KB] Merge-divide Main Sol Short Circuit	40-537
Failure code [DXE6KA] Merge-divide LS Sol Open Circuit	40-539
Failure code [DXE6KB] Merge-divide LS Sol Short Circuit	40-541
Failure code [DY20KA] Wiper Working Abnormality	40-543
Failure code [DY20MA] Wiper Parking Abnormality.....	40-545
Failure code [DY2CKB] Washer Drive Short Circuit.....	40-547
Failure code [DY2DKB] Wiper Drive (Fwd) Short Circuit	40-549
Failure code [DY2EKB] Wiper Drive (Rev) Short Circuit.....	40-551
Troubleshooting of electrical system (E-mode)	40-553
E-1 Engine does not start (Engine does not crank).....	40-553
E-2 Manual preheating system does not work.....	40-559
E-3 Automatic preheating system does not work.....	40-562
E-4 Preheating monitor does not light up when preheater is operated	40-564
E-5 When starting switch is turned to ON position, machine monitor displays nothing.....	40-566
E-6 When starting switch is turned to ON position (before starting engine), engine oil level monitor lights up in yellow.....	40-569
E-7 When starting switch is turned to ON position (before starting engine), radiator coolant level monitor lights up in yellow	40-570
E-8 Coolant temperature monitor lights up in white while engine is running	40-571
E-9 Hydraulic oil temperature monitor lights up in white while engine is running	40-572
E-10 Charge level monitor lights up while engine is running	40-573
E-11 Fuel level monitor lights up in red while engine is running.....	40-574
E-12 Air cleaner clogging monitor lights up in yellow while engine is running	40-575
E-13 Water separator monitor lights up while engine is running	40-576
E-14 Coolant temperature monitor lights up in red while engine is running.....	40-577
E-15 Hydraulic oil temperature monitor lights up in red while engine is running	40-578
E-16 Engine oil pressure monitor lights up in red while engine is running	40-579
E-17 Fuel gauge indicates either full or empty and does not move.....	40-580
E-18 Fuel gauge indicates incorrect amount (indicates neither full nor empty).....	40-581
E-19 Coolant temperature gauge indicates either Min. or Max. and does not move	40-582
E-20 Coolant temperature gauge indicates incorrect temperature (indicates neither Min. nor Max.).....	40-583
E-21 Hydraulic oil temperature gauge indicates either Min. or Max. and does not move	40-584
E-22 Hydraulic oil temperature gauge indicates incorrect temperature (indicates neither Min. nor Max.)	40-586
E-23 Content of display on machine monitor is different from that of actual machine	40-587
E-24 Machine monitor does not display some items	40-588
E-25 Function switch does not work.....	40-589
E-26 Automatic preheating system does not work (In cold season).....	40-590
E-27 Auto-deceleration monitor does not light up or does not go out when auto-deceleration switch is operated	40-591
E-28 Auto-deceleration is not actuated or canceled when lever is operated	40-592
E-29 Working mode selection screen is not displayed when working mode switch is operated	40-593
E-30 Engine or hydraulic pump setting does not change when working mode is changed.....	40-594
E-31 Travel speed monitor does not change when travel speed switch is operated	40-595
E-32 Travel speed does not change while travel speed selection is changed.....	40-596
E-33 Alarm buzzer does not stop sounding.....	40-597

E-35 Service mode cannot be selected	40-599
E-36 Any of work equipment, swing and travel does not work.....	40-600
E-37 Any of work equipment, swing and travel cannot be locked	40-602
E-38 Machine cannot swing while swing brake cancel switch is canceled	40-603
E-39 Swing brake does not operate while swing brake cancel switch is locked	40-605
E-40 One-touch power maximizing function does not work or monitor is not displayed	40-607
E-41 One-touch power maximizing function cannot be canceled	40-609
E-42 Travel alarm does not sound when machine travels.....	40-610
E-43 Alarm does not stop sounding while machine is stopped.....	40-611
E-44 Horn does not sound	40-612
E-45 Horn does not stop sounding.....	40-614
E-46 Wiper monitor does not light up or go out when wiper switch is operated	40-615
E-47 Wiper does not operate when wiper switch is operated	40-616
E-48 Window washer does not operate when window washer switch is operated.....	40-618
E-49 BOOM LOWER indication is not displayed properly with monitoring function	40-619
E-50 ARM DUMP indication is not displayed properly with monitoring function	40-620
E-51 ARM IN indication is not displayed properly with monitoring function.....	40-621
E-52 BOOM RAISE indication is not displayed properly with monitoring function	40-622
E-53 BUCKET CURL indication is not displayed properly with monitoring function	40-623
E-54 BUCKET DUMP indication is not displayed properly with monitoring function	40-624
E-55 SWING indication is not displayed properly with monitoring function	40-625
E-56 TRAVEL indication is not displayed properly with monitoring function.....	40-626
E-57 Service is not displayed properly with monitoring function	40-627
E-58 Attachment hydraulic circuit cannot be changed.....	40-630
E-59 KOMTRAX system does not operate normally	40-631
Troubleshooting of hydraulic and mechanical system (H-mode).....	40-633
Information described in troubleshooting table (H-mode)	40-633
System chart for hydraulic system	40-634
Failure mode and cause table	40-636
H-1 All of work equipment, swing and travel operation lacks speed or power	40-644
H-2 Engine speed drops significantly or engine stalls	40-647
H-3 All work equipment, swing and travel does not work	40-650
H-4 Unusual sound is heard from around hydraulic pump	40-651
H-5 Fine control performance or response is poor	40-652
H-6 Boom speed or power is low	40-654
H-7 Arm speed or power is low.....	40-658
H-8 Bucket speed or power is low.....	40-663
H-9 Work equipment does not move in single operation.....	40-666
H-10 Hydraulic drift of boom is large	40-667
H-11 Hydraulic drift of arm is large	40-668
H-12 Hydraulic drift of bucket is large.....	40-669
H-13 Time lag of work equipment is large	40-670
H-14 When part of work equipment is relieved singly, other parts of work equipment move	40-672
H-15 One-touch power maximizing function does not operate	40-673
H-16 In combined operation of work equipment, equipment having heavier load moves slower.....	40-674
H-17 In combined operations of swing and boom RAISE, boom rising speed is low.....	40-675
H-18 In combined operations of swing and travel, travel speed drops largely	40-676
H-19 Machine does not travel straight	40-677
H-20 Travel speed is slow	40-680
H-21 Machine is hard to steer or travel power is low	40-682
H-22 Travel speed does not change, or travel speed is too slow or fast.....	40-685
H-23 One of tracks does not run	40-686
H-24 Upper structure does not swing to the right or left.....	40-688
H-25 Upper structure swing only to the right or left	40-689
H-26 Swing acceleration or swing speed is low in both directions (right and left)	40-690
H-27 Swing acceleration performance is poor or swing speed is slow in only one direction.....	40-691

H-28 Upper structure overruns excessively when it stops swinging (both right and left).....	40-692
H-29 Upper structure overruns excessively when it stops swinging (either right or left)	40-693
H-30 Shock is large when upper structure stops swinging.....	40-694
H-31 Large unusual noise is heard when upper structure stops swinging	40-695
H-32 Swing drift on a slope is large while swing holding brake is applied.....	40-696
H-33 Swing drift on a slope is large while swing holding brake is released.....	40-697
H-34 Attachment hydraulic circuit cannot be changed while attachment is installed.....	40-698
H-35 Oil flow in attachment circuit cannot be controlled	40-699
Troubleshooting of engine (S-mode).....	40-700
Information mentioned in troubleshooting table (S mode).....	40-700
S-1 When starting switch is turned to START position, engine does not crank	40-701
S-2 Engine cranks but no exhaust smoke comes out.....	40-702
S-3 Fuel is being injected but engine does not start (misfiring: engine cranks but does not start).....	40-703
S-4 Engine startability is poor.....	40-704
S-5 Engine does not pick up smoothly	40-706
S-6 Engine stops during operation	40-708
S-7 Engine runs rough or is unstable	40-710
S-8 Engine lacks power	40-711
S-9 Exhaust smoke is black (KDPF clogs up early)	40-713
S-10 Engine oil consumption is excessive	40-715
S-11 Engine oil becomes contaminated early.....	40-716
S-12 Fuel consumption is excessive	40-717
S-13 Oil is in coolant (or coolant spurts or coolant level goes down).....	40-718
S-14 Engine oil pressure drops	40-719
S-15 Fuel is contaminated in engine oil	40-720
S-16 Coolant is contaminated in engine oil (Oil becomes cloudy white).....	40-721
S-17 Coolant temperature rises too high (overheating)	40-722
S-18 Unusual noise is heard	40-723
S-19 Vibration is excessive	40-724
S-20 Air cannot be bled from fuel circuit	40-725
S-21 Active regeneration is executed frequently	40-726
S-22 Active regeneration takes time.....	40-727
S-23 White smoke is exhausted during active regeneration	40-728
50 Disassembly and assembly	50-1
Table of contents	50-2
General information on disassembly and assembly.....	50-4
How to read this manual	50-4
Coating materials list	50-6
Special tools list	50-10
Sketches of special tools	50-15
Engine and cooling system.....	50-19
Removal and installation of supply pump assembly.....	50-19
Removal and installation of injector assembly	50-24
Removal and installation of cylinder head assembly.....	50-33
Removal and installation of radiator assembly	50-53
Removal and installation of hydraulic oil cooler assembly	50-55
Removal and installation of aftercooler assembly	50-58
Removal and installation of engine and main pump assembly	50-60
Removal and installation of engine front oil seal.....	50-72
Removal and installation of engine rear oil seal.....	50-76
Removal and installation of fuel cooler assembly	50-79
Removal and installation of fuel tank assembly	50-80
Removal and installation of engine hood assembly	50-83
Removal and installation of KDPF assembly.....	50-86
Disassembly and assembly of KDPF	50-94
Removal and installation of KCCV assembly	50-102
Removal and installation of air cleaner assembly	50-106

Power train.....	50-109
Removal and installation of travel motor and final drive assembly	50-109
Disassembly and assembly of final drive	50-110
Removal and installation of swing motor and swing machinery assembly	50-118
Disassembly and assembly of swing machinery.....	50-121
Removal and installation of swing circle assembly	50-128
Undercarriage and frame.....	50-129
Separation and connection of track shoe assembly	50-129
Removal and installation of sprocket.....	50-132
Removal and installation of idler and idler cushion assembly	50-133
Disassembly and assembly of idler assembly	50-134
Disassembly and assembly of idler cushion.....	50-137
Disassembly and assembly of track roller assembly	50-139
Disassembly and assembly of carrier roller.....	50-141
Removal and installation of revolving frame assembly	50-144
Removal and installation of counterweight assembly	50-146
Hydraulic system	50-149
Removal and installation of center swivel joint assembly	50-149
Disassembly and assembly of center swivel joint	50-152
Removal and installation of hydraulic tank assembly	50-153
Removal and installation of main pump assembly	50-157
Removal and installation of control valve assembly	50-161
Disassembly and assembly of control valve.....	50-168
Disassembly and assembly of work equipment PPC valve.....	50-173
Disassembly and assembly of travel PPC valve	50-175
Work equipment	50-178
Removal and installation of work equipment assembly	50-178
Disassembly and assembly of work equipment cylinder.....	50-181
Cab and its attachments	50-187
Removal and installation of operator's cab assembly.....	50-187
Removal and installation of operator cab glass (adhered glass)	50-192
Removal and installation of front window assembly	50-202
Removal and installation of floor frame assembly.....	50-208
Removal and installation of air conditioner unit assembly.....	50-214
Removal and installation of operator's seat.....	50-218
Removal and installation of seat belt.....	50-220
Removal and installation of front wiper assembly	50-222
Electrical system	50-229
Removal and installation of air conditioner compressor assembly.....	50-229
Removal and installation of air conditioner condenser assembly	50-232
Removal and installation of engine controller assembly	50-234
Removal and installation of pump controller assembly.....	50-236
Removal and installation of machine monitor assembly	50-239
Removal and installation of pump swash plate sensor.....	50-241
Removal and installation of mass air flow and temperature sensor	50-242
Removal and installation of KOMTRAX terminal assembly	50-243
60 Maintenance standard.....	60-1
Table of contents	60-2
Engine and cooling system	60-3
Engine mount	60-3
Cooling system	60-4
Power train.....	60-5
Swing circle	60-5
Swing machinery	60-6
Final drive	60-8
Sprocket.....	60-10
Undercarriage and frame.....	60-12
Track frame and idler cushion	60-12
Idler	60-14

Track roller	60-16
Carrier roller	60-17
Track shoe	60-18
Hydraulic system	60-24
Hydraulic tank	60-24
Main pump	60-25
Control valve	60-26
Swing motor	60-36
Travel motor	60-38
Work equipment and swing PPC valve	60-41
Travel PPC valve	60-44
1st-line attachment PPC valve (with EPC valve)	60-47
2nd-line attachment PPC valve	60-50
Solenoid valve	60-52
Attachment circuit selector valve (for high-pressure circuit)	60-53
Attachment circuit selector valve (for low-pressure circuit)	60-54
Center swivel joint	60-55
Work equipment	60-56
Work equipment	60-56
Boom cylinder (large diameter piston)	60-65
Arm cylinder	60-66
Bucket cylinder	60-67
80 Appendix	80-1
Table of contents	80-2
Air conditioner components	80-3
Precautions for refrigerant	80-3
Air conditioner component	80-4
Configuration and function of refrigeration cycle	80-7
Outline of refrigeration cycle	80-8
Air conditioner unit	80-10
Dual pressure switch	80-17
Air conditioner controller	80-18
Compressor	80-19
Air conditioner condenser	80-20
Sunlight sensor	80-22
Outer temperature sensor (outside air temperature sensor)	80-23
Procedure for testing and troubleshooting	80-24
Circuit diagram and arrangement of connector pins	80-26
System diagram	80-28
Input and output signals of the air conditioner controller	80-29
Parts and connectors layout	80-31
Testing air leakage (duct)	80-35
Testing with self-diagnosis function	80-38
Testing vent (mode) changeover	80-40
Testing FRESH/RECIRC air changeover	80-42
Testing sunlight sensor	80-43
Testing (dual) pressure switch for refrigerant	80-44
Testing relays	80-45
Troubleshooting chart 1	80-46
Troubleshooting chart 2	80-47
Information in troubleshooting table	80-50
Failure code list related to air conditioner	80-51
Failure code [879AKA] A/C Inner Sensor Open Circuit	80-52
Failure code [879AKB] A/C Inner Sensor Short Circuit	80-53
Failure code [879BKA] A/C Outer sensor Open Circuit	80-54
Failure code [879BKB] A/C Outer sensor Short Circuit	80-56
Failure code [879CKA] Ventilating Sensor Open Circuit	80-58
Failure code [879CKB] Ventilating Sensor Short Circuit	80-59
Failure code [879DKZ] Sunlight sensor Open or Short Circuit	80-60

Failure code [879EMC] Ventilation Damper Abnormality	80-62
Failure code [879FMC] Air Mix Damper Abnormality	80-63
Failure code [879GKX] Refrigerant Abnormality	80-64
A-1 Troubleshooting for power supply system (Air conditioner does not operate)	80-65
A-2 Troubleshooting of compressor system (Air is not cooled).....	80-67
A-3 Troubleshooting for blower motor system (No air comes out or air flow is abnormal)	80-70
A-4 Troubleshooting for FRESH/RECIRC air changeover	80-72
Troubleshooting with gauge pressure.....	80-74
Connection of service tool.....	80-77
Precautions for disconnecting and connecting air conditioner piping	80-79
Handling of compressor oil.....	80-81
Desiccant replacement	80-83
90 Diagrams and drawings	90-1
Table of contents	90-2
Hydraulic circuit diagram	90-3
Symbols in hydraulic circuit diagram	90-3
Hydraulic circuit diagram.....	90-7
Electric circuit diagram	90-9
Symbols in electric circuit diagram	90-9
Electric circuit diagram.....	90-13
Electric circuit diagram for air conditioner unit	90-25
Index.....	1

Foreword, safety and general information (ALL-0370-001-A-00-A)

Important safety notice (ALL-1120-012-A-01-A)

(Rev. 2012/01)

- Appropriate servicing and repair are extremely important to ensure safe operation of the machine. The shop manual describes the effective and safe servicing and repair methods recommended by Komatsu. Some of these methods require the use of the special tools designed by Komatsu for the specific purpose.
- The symbol mark  is used for such matters that require special cautions during the work. The work indicated by the caution mark should be performed according to the instructions with special attention to the cautions. Should hazardous situation occur or be anticipated during such work, be sure to keep safe first and take every necessary measure.

General precautions

 **Inappropriate handling causes an extreme danger. Read and understand what is described in the operation and maintenance manual before operating the machine. Read and understand what is described in this manual before starting the work.**

- Before performing any greasing or repairs, read all the safety labels stuck to the machine. For the locations of the safety labels and detailed explanation of precautions, see the operation and maintenance manual.
- Locate a place in the repair workshop to keep the tools and removed parts. Always keep the tools and parts in their correct places. Always keep the work area clean and make sure that there is no dirt, water or oil on the floor. Smoke only in the areas provided for smoking. Never smoke while working.
- When performing any work, always wear the safety shoes and helmet. Do not wear loose work cloths, or clothes with buttons missing.
 1. Always wear the protective eyeglasses when hitting parts with a hammer.
 2. Always wear the protective eyeglasses when grinding parts with a grinder, etc.
- When performing any work with two or more workers, always agree on the working procedure before starting. While working, always keep conversations of the work between your fellow workers and your self on any step of the work. During the work, hang the warning tag of "UNDER WORKING" in the operator's compartment.
- Only qualified workers must perform the work and operation which require license or qualification.
- Keep the tools in good condition. And learn the correct way to use the tools, and use the proper ones among them. Before starting the work, thoroughly check the tools, forklift truck, service car, etc.
- If welding repairs is required, always have a trained and experienced welder with good

knowledge of welding perform the work. When performing welding work, always wear welding gloves, apron, shielding goggles, cap, etc.

- Before starting work, warm up your body thoroughly to start work under good condition.
- Avoid continuing work for long hours and take rests with proper intervals to keep your body in good condition. Take a rest in a specified safe place.

Safety points

1	Good arrangement
2	Correct work clothes
3	Observance of work standard
4	Practice of making and checking signals
5	Prohibition of operation and handling by unlicensed workers
6	Safety check before starting work
7	Wearing protective goggles (for cleaning or grinding work)
8	Wearing shielding goggles and protectors (for welding work)
9	Good physical condition and preparation
10	Precautions against work which you are not used to or you are used to too much

Preparation

- Before adding oil or making any repairs, place the machine on a firm and level ground, and apply the parking brake and chock the wheels or tracks to prevent the machine from moving.
- Before starting work, lower the work equipment (blade, ripper, bucket, etc.) to the ground. If it is not possible to lower the equipment to the ground, insert the lock pin or use blocks to prevent the work equipment from falling. And be sure to lock all the work equipment control levers and hang a warning tag on them.
- When performing the disassembling or assembling work, support the machine securely with blocks, jacks, or stands before starting the work.
- Remove all of mud and oil from the steps or other places used to get on and off the machine completely. Always use the handrails, ladders of

steps when getting on or off the machine. Never jump on or off the machine. When the scaffold is not provided, use steps or stepladder to secure your footing.

Precautions during work

- For the machine equipped with the battery disconnect switch, check that the system operating lamp is turned off before starting the work. Then, turn the battery disconnect switch to the OFF (○) position and remove the switch key. For the machine not equipped with the battery disconnect switch, remove the cable from the battery before starting the work. Be sure to remove the negative end (-) of the battery cable first.
- Release the remaining pressure in the circuits completely before the work when the parts in the circuits of oil, fuel, coolant and air are disconnected or removed. When the cap of the oil filter, drain plug or oil pressure pickup plug is removed, loose them slowly to prevent the oil from spurting out.
- When removing or installing the checking plug or the piping in the fuel circuit, wait 30 seconds or longer after the engine is shut down and start the work after the remaining pressure is released from the fuel circuit.
- Immediately after the engine is shut down, the coolant and oil in the circuits are hot. Be careful not to get scalded by the hot coolant and oil. Start the work after checking that the coolant and oil are cooled down sufficiently.
- Start the work after the engine is shut down. Be sure to shut down the engine when working on or around the rotating parts in particular. When checking the machine without shutting down the engine (measuring oil pressure, engine speed, oil or coolant temperature), take extreme care not to get caught in the rotating parts or the working equipment.
- The hoist or crane must be used to sling the components weighing 25 kg or heavier. Check the slings (wire rope, nylon sling, chain and hook) for damage before the work. Use the slings with ample capacity and install them to the proper places. Operate the hoist or crane slowly to prevent the component from hitting any other part. Do not work with any part still raised by the hoist or crane.
- When removing the part which is under internal pressure or reaction force of the spring, always leave two bolts in diagonal positions. Loosen those two bolts gradually and alternately and release the pressure, then, remove the part.
- When removing the part, be careful not to break or damage the electrical wiring. The damaged wiring may cause electrical fires.
- When removing piping, prevent the fuel or oil from spilling out. If any fuel or oil drips onto the floor, wipe it off immediately. Fuel or oil on the floor can cause you to slip and can even cause fires.
- As a general rule, do not use gasoline to wash parts. Do not use gasoline to clean the electrical parts, in particular.
- Reinstall the parts removed to their original places. Replace the damaged parts and the parts which must not be used with new ones. When installing the hoses and wiring harnesses, be careful that they are not damaged by contacting with other parts when the machine is operated.
- When connecting the high pressure hoses and tubes, make sure that they are not twisted. The damaged high pressure hoses and tubes are very dangerous when they are installed. So, be extremely careful when connecting the high pressure pipings. In addition, check that their connections are correct.
- When assembling or installing the parts, be sure to tighten the bolts to the specified torque. When installing the protective parts such as guards, or the parts which vibrate violently or rotate at high speeds, be sure to check that they are installed correctly.
- When aligning two holes, never insert your fingers or hand into the holes. Align the holes with care so that your fingers are not caught in the hole.
- When measuring hydraulic pressure, check that the measuring tools are correctly installed.
- Pay attention to safety when removing and installing the tracks of the track type machines. When removing the track, it separates suddenly. The workers should not stand at either end of the track.
- If the engine is operated for a long time in a closed place which is not ventilated well, you may suffer from gas poisoning. Accordingly, open the windows and doors to ventilate the place well.

Precautions for slinging work and making signals

- Only one appointed worker must make signals and co-worker must communicate with each other frequently. The appointed signaler must make specified signals clearly at the place where the signaler is well seen from the operator's seat and where the signaler can see the working condition easily. The signaler must always stand in front of the load and guide the operator safely.
 1. Do not stand under the load.
 2. Do not step on the load.
- Check the slings before starting sling work.

00 Index and foreword

Foreword, safety and general information

- Keep putting on the gloves during sling work. (Put on the leather gloves, if available.)
- Measure the weight of the load by the eye and check its center of gravity.
- Use the proper sling according to the weight of the load and method of slinging. If too thick wire ropes are used to sling a light load, the load may slip and fall.
- Do not sling a load with one wire rope only. If do so, the load may rotate or the sling gets loose and the sling may slip off. Install two or more wire ropes symmetrically.

⚠ Slinging with one rope may cause turning of the load during hoisting, untwisting of the rope, or slipping of the rope from its original slinging position on the load, which can result in a dangerous accident.

- Hanging angle must be 60 degrees or smaller as a rule.
- When hanging a heavy load (25kg or heavier), the hanging angle of the rope must be narrower than that of the hook.
 - ★ When slinging a load with two ropes or more, the larger the hanging angle is, the larger the tension of each rope. The figure below shows the variation of allowable load in kN {kg} when hoisting is made with two ropes, each of which is allowed to sling up to 9.8 kN {1000kg} a load vertically, at various hanging angles. When the two ropes sling a load vertically, up to 19.6 kN {2000 kg} of total weight can be suspended. This weight is reduced to 9.8 kN {1000 kg} when the two ropes make a hanging angle of 120 degrees. If the two ropes sling a 19.6 kN {2000 kg} load at a hanging angle of 150 degrees, each rope is subjected to a force as large as 39.2 kN {4000 kg}.

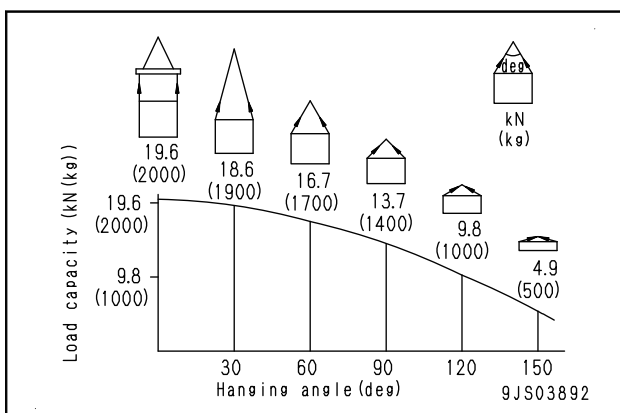

- When installing wire ropes to an angular load, apply pads to protect the wire ropes. If the load is slippery, apply proper material to prevent the wire rope from slipping.

- Use the specified eye bolts and fix wire ropes, chains, etc. to them with shackles, etc.
- Apply wire ropes to the middle portion of the hook.
 - ★ Slinging near the tip of the hook may cause the rope to slip off the hook during hoisting. The hook has the maximum strength at the middle part.

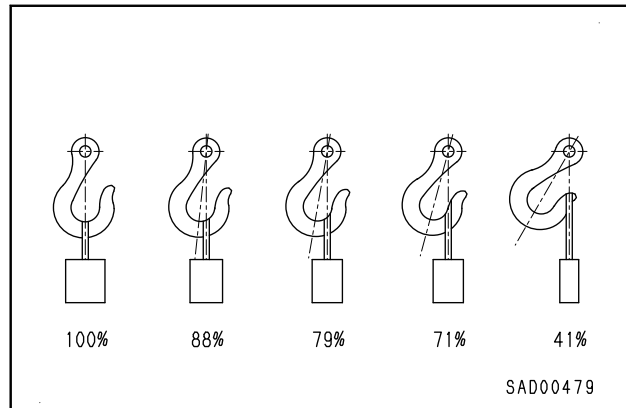

- Do not use twisted or kinked wire ropes.
- When slinging up a load, observe the following.
 1. Wind up the rope slowly until the wire rope tensions. When putting your hands on the wire ropes, do not grasp them but press them down from above. If you grasp them, your fingers may be caught.
 2. After the wire ropes are stretched, stop the crane and check the condition of the slung load, wire ropes, and pads.
 3. If the load is unstable or the wire rope or chains are twisted, lower the load and lift it up again.
 4. Do not lift up the load at an angle.
- When lowering a load, pay attention to the following.
 1. When lifting down a load, stop it temporarily at 30 cm above the floor, and then lower it slowly.
 2. Check that the load is stable, and then remove the sling.
 3. Remove kinks and dirt from the wire ropes and chains used for the sling work, and put them in the specified place.

Precautions for using mobile crane

- ★ Read the Operation and Maintenance Manual of the crane carefully in advance and operate the crane safely.

Precautions for using overhead traveling crane

⚠ The hoist or crane must be used to sling the components weighing 25 kg or heavier. A part weighing 25 kg or heavier in "disassembly and assembly" section is indicated with the symbol of .

- Before starting work, check the wire ropes, brake, clutch, controller, rails, over winding prevention device, ground fault circuit interrupter for electric shock prevention, crane collision prevention device, and energizing warning lamp, and check the following safety items.
- Observe the signals for sling work.
- Operate the hoist at a safe place.
- Be sure to check the directions of the direction indication plate (north, south, east and west) and the operating button.
- Do not sling a load at an angle. Do not move the crane while the slung load is swinging.
- Do not raise or lower a load while the crane is moving longitudinally or laterally.
- Do not drag a sling.
- When lifting up a load, stop it just after it leaves the ground and check safety, and then lift it up.
- Consider the travel route in advance and lift up a load to a safe height.
- Place the control switch in a position where it will not be an obstacle to work and passage.
- After operating the hoist, do not swing the control switch.
- Remember the position of the main switch so that you can turn off the power immediately in an emergency.
- Shut down the main switch when the hoist stops because of a blackout. When turning on a switch which is turned OFF by the ground fault circuit interrupter for electric shock prevention, check that the devices related to that switch are not in operating condition.
- If you find an obstacle around the hoist, stop the operation.
- After finishing the work, stop the hoist at the specified position and raise the hook to at least two meters above the floor. Do not leave the sling attached to the hook.

Selecting wire ropes

- Select adequate ropes depending on the weight of the parts to be hoisted, referring to the table below

Wire ropes (standard "Z" twist ropes without galvanizing) (JIS G3525, Type 6x37-A)

Nominal diameter of rope	Allowable load	
	kN	ton
mm		
10	8.8	0.9

Nominal diameter of rope	Allowable load	
	kN	ton
mm		
12	12.7	1.3
14	17.3	1.7
16	22.6	2.3
18	28.6	2.9
20	35.3	3.6
25	55.3	5.6
30	79.6	8.1
40	141.6	14.4
50	221.6	22.6
60	318.3	32.4

★ The allowable load is calculated as one sixth of the breaking load of the rope to be used (safety coefficient: 6).

Precautions for disconnecting and connecting hoses and tubes in air conditioner circuit

Disconnection

⚠ When replacing the air conditioner unit, air conditioner compressor, condenser or receiver drier, etc., collect the refrigerant (air conditioner gas: R134a) from the air conditioner circuit before disconnecting the air conditioner hoses.

- ★ Ask a qualified person for collecting, adding and filling operations of the refrigerant (air conditioner gas: R134a).
- ★ Never release the refrigerant (air conditioner gas: R134a) to the atmosphere.

⚠ If refrigerant gas (air conditioner gas: R134a) gets in your eyes, you may lose your sight. And if it touches your skin, you may suffer from frostbite. Put on protective eyeglasses, gloves and working cloth with long sleeves while collecting the refrigerant or filling the air conditioner circuit with the refrigerant.

- When loosening the nuts fixing air conditioner hoses and tubes, be sure to use two wrenches; use one wrench to fix and use the other one to loosen the nut.

Connection

- When installing the hose for the air conditioner circuit, take care not to allow invasion of dirt, dusts and water into the hose.
- Check that the O-rings are fitted to the joints when connecting the air conditioner piping.
- Once an O-ring is used, it is deformed and deteriorated. Accordingly, do not reuse it.
- When removing the O-rings, use a soft tool so that the piping is not damaged.

00 Index and foreword**Foreword, safety and general information**

- Check that the O-ring is not damaged or deteriorated.
- Apply compressor oil for refrigerant (R134a) to the O-ring.
 - ★ However, do not apply oil to the threaded portion of a bolt, nut or union.

Manufacturer	Part name
DENSO	ND-OIL8
VALEO THERMAL SYSTEMS	ZXL100PG (equivalent to PAG46)
SANDEN	SP-10

- When tightening nuts of the air conditioner hoses and tubes, be sure to use two wrenches. Use one wrench to fix and tighten the nut with the other wrench to the specified torque (Use a torque wrench for tightening).
- ★ Example of fitting of O-ring
 - An O-ring is fitted to every joint of the air conditioner piping.

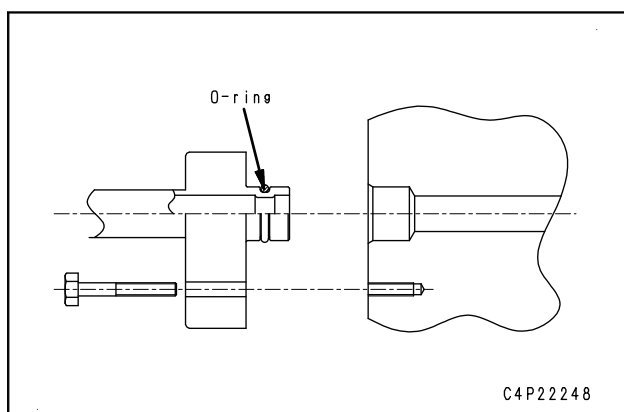
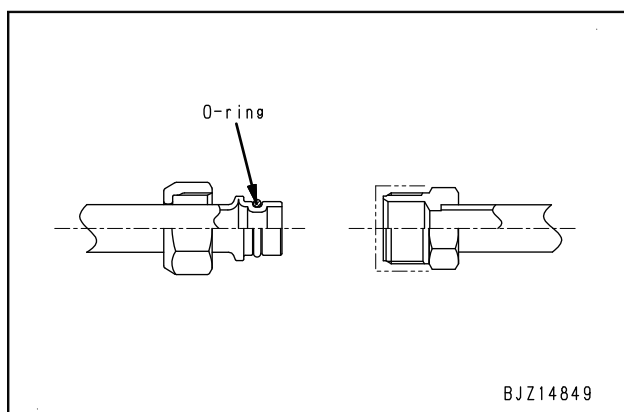

**For tightening torques, see "Others",
"Precautions for disconnection and connection
of air conditioner piping".**