

SHOP MANUAL

KOMATSU

D40A,P-3

D41A,E,P-3

D41A-3A

MACHINE MODEL	SERIAL No.
D40A-3	60001 and up
D40P-3	60001 and up
D40PL-3	60001 and up
D40PLL-3	60001 and up
D41A-3	60001 and up
D41E-3	60001 and up
D41P-3	60001 and up
D41A-3A	60001 and up

- This shop manual may contain attachments and optional equipment that are not available in your area. Please consult your local Komatsu distributor for those items you may require. Materials and specifications are subject to change without notice.
- D40 · 41-3 mount the 6D105-1 engine.
For details of the engine, see the 105 Series Engine Shop Manual.

CONTENTS

	No. of page
01 GENERAL	01-1
10 ENGINE	
11 STRUCTURE AND FUNCTION	11-1
12 TESTING AND ADJUSTING	12-1
13 DISASSEMBLY AND ASSEMBLY	13-1
20 POWER TRAIN	
21 STRUCTURE AND FUNCTION	21-1
22 TESTING AND ADJUSTING	22-1
23 DISASSEMBLY AND ASSEMBLY	23-1
24 MAINTENANCE STANDARD	24-1
30 UNDERCARRIAGE	
31 STRUCTURE AND FUNCTION	31-1
33 DISASSEMBLY AND ASSEMBLY	33-1
34 MAINTENANCE STANDARD	34-1
60 HYDRAULIC SYSTEM	
61 STRUCTURE AND FUNCTION	61-1
62 TESTING AND ADJUSTING	62-1
63 DISASSEMBLY AND ASSEMBLY	63-1
64 MAINTENANCE STANDARD	64-1
70 WORK EQUIPMENT	
71 STRUCTURE AND FUNCTION	71-1
73 DISASSEMBLY AND ASSEMBLY	73-1
74 MAINTENANCE STANDARD	74-1
90 OTHERS	
90 ELECTRICAL SYSTEM	90-1

The affected pages are indicated by the use of the following marks. It is requested that necessary actions must be taken to these pages according to the list below.

Mark	Indication	Action required
○	Page to be newly added	Add
●	Page to be replaced	Replace
()	Page to be deleted	Discard

Pages having no marks are not revised at this time.

LIST OF REVISED PAGES

Mark	Pages	Revision number	Mark	Pages	Revision number	Mark	Pages	Revision number	Mark	Pages	Revision number	Mark	Pages	Revision number
●	00- 1	⑦		11- 7			13-25	①		21- 4	⑤		21-43	①
	00- 2	⑤		12- 1	①		13-26	①		21- 5	⑤		21-44	①
●	00- 2 -1	⑦		12- 3	①		13-27	①		21- 6	④		21-45	①
●	00- 2 -2	⑦		12- 4	④		13-28	①		21- 7			21-45-1	③
●	00- 2 -3	⑦		12- 5	④		13-29	①		21- 8			21-45-2	③
	00- 3			12- 6	①		13-30	①		21- 9			21-46	⑤
	00- 4			12- 7	①		13-32	①		21-10			21-46-1	③
	00- 5			12- 8	①		13-33	①		21-11			21-47	②
	00- 6			12- 9	①		13-34	①		21-12			21-48	
	00- 7			12-10	①		13-35	①		21-13			21-49	
	00- 8			12-11	①		13-36	①		21-14			21-50	①
	00- 9			12-12	①		13-37	①		21-15			21-51	①
	00-10			12-13	①		13-38	①		21-16			21-52	①
	01- 0	①		12-14	①		13-39	①		21-17			21-52-1	③
	01- 1	⑥		12-15	①		13-40	①		21-18			21-53	③
	01- 2	③		12-16	①		13-41	①		21-19			21-54	③
	01- 3	④		12-17	①		13-42	①		21-20			21-55	
	01- 4	④		12-18	①		13-43	①		21-21			21-56	①
	01- 5	④		12-19	①		13-44	①		21-22			21-57	①
	01- 6	④		13- 1	①		13-45	①		21-23			21-58	①
	01- 6 -1	③		13- 3	①		13-46	①		21-24	⑤		21-59	③
	01- 6 -2	③		13- 4	①		13-47	①		21-24-1	⑤		21-60	
	01- 6 -4	③		13- 5	①		13-48	①		21-25			21-61	
	01- 6 -5	③		13- 6	①		13-49	①		21-26			21-62	③
	01- 6 -6	③		13- 7	①		13-50	①		21-27			21-63	③
	01- 7	③		13- 8	①		13-51	①		21-28	②		22- 1	①
	01- 9	④		13- 9	①		13-52	①		21-29			22- 3-	④
	01-10	④		13-10	①		13-53	①		21-30			22- 4	①
	01-11	④		13-11	①		13-54	①		21-31			22- 5	①
	01-12	③		13-12	①		13-55	①		21-32			22- 6	①
	01-13	⑥		13-13	①		13-56	①		21-33	④		22- 7	①
	01-14	⑥		13-14	①		13-57	①		21-34			22- 8	①
	01-15	⑥		13-16	①		13-58	①		21-35	②		22- 9	①
	11- 0	①		13-17	①		13-59	①		21-36	②		22-10	⑥
	11- 1	①		13-18	①		13-60	①		21-37	②		22-10-1	⑥
	11- 2			13-19	①		13-61	①		21-38			22-10-2	⑥
	11- 3			13-20	①		21- 0	①		21-39	①		22-11	①
	11- 4			13-21	①		21- 1	③		21-40	①		22-12	①
	11- 5			13-22	①		21- 2	⑤		21-41	⑤		22-13	①
	11- 6			13-24	①		21- 3	⑤		21-42			22-14	①



Mark	Pages	Revision number	Mark	Pages	Revision number	Mark	Pages	Revision number	Mark	Pages	Revision number	Mark	Pages	Revision number
22-15		①	23-53-1		⑥	23-107		①	23-165		①	33- 3		①
22-16		④	23-53-2		⑤	23-108		①	23-166		①	33- 4		①
22-17		④	23-53-3		⑥	23-109		①	23-167		①	33- 5		①
22-17-1		⑥	23-53-4		⑥	23-110		①	23-168		①	33- 6		①
22-18		⑤	23-54		①	23-111		①	23-169		①	33- 7		①
22-19		⑤	23-55		①	23-112		①	23-170		①	33- 8		①
23- 1		①	23-56		⑤	23-113		①	23-171		①	33- 9		①
23- 3		①	23-57		①	23-114		①	23-172		①	33-10		①
23- 4		①	23-58		①	23-115		①	23-173		④	33-11		①
23- 5		①	23-59		①	23-116		①	23-174		①	33-12		①
23- 6		①	23-60		①	23-117		⑥	23-175		①	33-13		①
23- 7		①	23-61		①	23-118		①	23-176		①	33-14		①
23- 8		①	23-62		①	23-119		①	23-177		①	33-15		①
23- 9		①	23-63		①	23-120		①	24- 0		①	33-16		①
23-10		①	23-64		①	23-122		①	24- 1		③	33-17		①
23-11		①	23-65		①	23-123		①	24- 2		③	33-18		①
23-12		①	23-66		①	23-124		①	24- 3		③	33-20		①
23-14		①	23-67		①	23-125		①	24- 4		③	33-21		①
23-15		①	23-68		①	23-126		①	24- 5-1		③	33-22		①
23-16		①	23-69		①	23-127		①	24- 5-2		③	33-23		①
23-17		①	23-70		①	23-128		①	24- 6		②	33-24		①
23-18		①	23-71		①	23-129		①	24- 7		⑤	33-25		①
23-19		①	23-72		①	23-130		①	24- 7-1		⑤	34- 0		①
23-20		①	23-73		①	23-132		①	24- 8		③	34- 1		③
23-21		①	23-74		①	23-133		①	24- 8-1		③	34- 2		③
23-22		①	23-75		①	23-134		①	24- 8-2		③	34- 2 -1		③
23-23		①	23-76		①	23-135		④	24- 10		③	34- 2 -2		③
23-24		①	23-77		①	23-136		①	24- 11		③	34- 3		③
23-25		①	23-78		①	23-137		①	24- 12		③	34- 3 -1		③
23-26		①	23-79		①	23-138		①	24- 13		⑥	34- 3 -2		③
23-27		①	23-80		①	23-139		①	24- 14		③	34- 3 -3		③
23-28		①	23-81		①	23-140		①	24- 15		④	34- 3 -4		③
23-29		①	23-82		①	23-141		①	24- 16		②	34- 4		
23-30		①	23-83		①	23-142		①	24- 16-1		③	34- 5		
23-31		①	23-84		①	23-143		①	24- 16-2		③	34- 6		③
23-32		①	23-86		①	23-144		①	24- 17		③	34- 7		②
23-33		①	23-87		①	23-145		①	24- 18		③	34- 8		③
23-34		①	23-88		①	23-146		①	24- 19		④	34- 9		③
23-35		①	23-89		①	23-148		①	24- 20		③	34-10		②
23-36		①	23-90		①	23-149		①	24- 21		②	34-11		③
23-38		①	23-91		①	23-150		①	31- 0		①	34-12		②
23-39		①	23-92		①	23-151		①	31- 1		③	34-13		④
23-40		①	23-93		①	23-152		①	31- 2		③	34-14		
23-41		①	23-94		①	23-153		①	31- 2-1		②	34-15		
23-42		①	23-95		①	23-154		①	31- 3		②	34-16		③
23-43		①	23-96		①	23-155		①	31- 4			61- 0		①
23-44		①	23-97		①	23-156		①	31- 5			61- 1		②
23-45		①	23-98		①	23-157		①	31- 6			61- 2		②
23-46		①	23-99		①	23-158		①	31- 7			61- 3		②
23-48		⑥	23-100		①	23-159		①	31- 8		③	61- 3 -1		②
23-49		①	23-101		①	23-160		①	31- 8-1		③	61- 4		②
23-50		①	23-102		①	23-161		①	31- 8-2		③	61- 5		②
23-51		⑥	23-103		①	23-162		①	31- 8-3		③	61- 5 -1		②
23-52		①	23-104		①	23-163		①	31- 9			61- 5 -2		③
23-53		⑥	23-106		①	20-164		①	33- 1		①	61- 6		②

Mark	Pages	Revision number	Mark	Pages	Revision number	Mark	Pages	Revision number	Mark	Pages	Revision number
61- 6 -1		②	64- 5		③						
61- 7		②	71- 0		①						
61- 8		②	71- 1		②						
61- 8 -1		②	71- 2								
61- 9			71- 3		②						
61- 9 -1		②	71- 4		②						
61- 9 -2		②	73- 1		①						
61-10		①	73- 3		④						
61-11		①	73- 4		①						
61-12		②	73- 5		①						
61-13		②	73- 6		①						
61-14		③	73- 7		①						
61-15		③	73- 8		④						
61-16		②	73- 9		④						
61-17		②	74- 0		①						
61-18		②	74- 1		③						
62- 1		①	74- 2		③						
62- 3		①	74- 3		③						
62- 4		①	74- 4		③						
62- 5		①	74- 5		③						
62- 6		①	74- 6		②						
62- 7		①	74- 7		②						
62- 8		①	90- 0		①						
62- 9		①	● 90- 1		⑦						
62-10		①	(90- 2)								
63- 1		①	○ 90- 3		⑦						
63- 3		①	○ 90- 4		⑦						
63- 4		①									
63- 5		①									
63- 6		①									
63- 7		①									
63- 8		①									
63- 9		①									
63-10		①									
63-12		①									
63-13		①									
63-14		①									
63-15		①									
63-16		①									
63-17		①									
63-18		①									
63-19		①									
63-20		①									
63-21		①									
64- 0		①									
64- 1		③									
64- 2		③									
64- 3		③									
64- 3 -1		③									
64- 3 -2		③									
64- 4		③									
64- 4 -1		③									
64- 4 -2		③									
64- 4 -3		③									
64- 4 -4		③									



IMPORTANT SAFETY NOTICE

Proper service and repair is extremely important for the safe operation of your machine. The service and repair techniques recommended by Komatsu and described in this manual are both effective and safe methods of operation. Some of these operations require the use of tools specially designed by Komatsu for the purpose.

To prevent injury to workers, the symbols  and  are used to mark safety precautions in this manual. The cautions accompanying these symbols should always be followed carefully. If any dangerous situation arises or may possibly arise, first consider safety, and take the necessary actions to deal with the situation.



SAFETY

GENERAL PRECAUTIONS

Mistakes in operation are extremely dangerous. Read the Operation and Maintenance Manual carefully **BEFORE** operating the machine.

1. Before carrying out any greasing or repairs, read all the precautions given on the decals which are fixed to the machine.
2. When carrying out any operation, always wear safety shoes and helmet. Do not wear loose work clothes, or clothes with buttons missing.
 - Always wear safety glasses when hitting parts with a hammer.
 - Always wear safety glasses when grinding parts with a grinder, etc.
3. If welding repairs are needed, always have a trained, experienced welder carry out the work. When carrying out welding work, always wear welding gloves, apron, glasses, cap and other clothes suited for welding work.
4. When carrying out any operation with two or more workers, always agree on the operating procedure before starting. Always inform your fellow workers before starting any step of the operation. Before starting work, hang **UNDER REPAIR** signs on the controls in the operator's compartment.
5. Keep all tools in good condition and learn the correct way to use them.

6. Decide a place in the repair workshop to keep tools and removed parts. Always keep the tools and parts in their correct places. Always keep the work area clean and make sure that there is no dirt or oil on the floor. Smoke only in the areas provided for smoking. Never smoke while working.

PREPARATIONS FOR WORK

7. Before adding oil or making any repairs, park the machine on hard, level ground, and block the wheels or tracks to prevent the machine from moving.
8. Before starting work, lower blade, ripper, bucket or any other work equipment to the ground. If this is not possible, insert the safety pin or use blocks to prevent the work equipment from falling. In addition, be sure to lock all the control levers and hang warning signs on them.
9. When disassembling or assembling, support the machine with blocks, jacks or stands before starting work.
10. Remove all mud and oil from the steps or other places used to get on and off the machine. Always use the handrails, ladders or steps when getting on or off the machine. Never jump on or off the machine. If it is impossible to use the handrails, ladders or steps, use a stand to provide safe footing.

PRECAUTIONS DURING WORK

11. When removing the oil filler cap, drain plug or hydraulic pressure measuring plugs, loosen them slowly to prevent the oil from spurting out.
Before disconnecting or removing components of the oil, water or air circuits, first remove the pressure completely from the circuit.
12. The water and oil in the circuits are hot when the engine is stopped, so be careful not to get burned.
Wait for the oil and water to cool before carrying out any work on the oil or water circuits.
13. Before starting work, remove the leads from the battery. Always remove the lead from the negative (—) terminal first.
14. When raising heavy components, use a hoist or crane.
Check that the wire rope, chains and hooks are free from damage.
Always use lifting equipment which has ample capacity.
Install the lifting equipment at the correct places. Use a hoist or crane and operate slowly to prevent the component from hitting any other part. Do not work with any part still raised by the hoist or crane.
15. When removing covers which are under internal pressure or under pressure from a spring, always leave two bolts in position on opposite sides. Slowly release the pressure, then slowly loosen the bolts to remove.
16. When removing components, be careful not to break or damage the wiring. Damaged wiring may cause electrical fires.
17. When removing piping, stop the fuel or oil from spilling out. If any fuel or oil drips on to the floor, wipe it up immediately. Fuel or oil on the floor can cause you to slip, or can even start fires.
18. As a general rule, do not use gasoline to wash parts. In particular, use only the minimum of gasoline when washing electrical parts.
19. Be sure to assemble all parts again in their original places.
Replace any damaged parts with new parts.
 - When installing hoses and wires, be sure that they will not be damaged by contact with other parts when the machine is being operated.
20. When installing high pressure hoses, make sure that they are not twisted. Damaged tubes are dangerous, so be extremely careful when installing tubes for high pressure circuits. Also, check that connecting parts are correctly installed.
21. When assembling or installing parts, always use the specified tightening torques. When installing protective parts such as guards, or parts which vibrate violently or rotate at high speed, be particularly careful to check that they are installed correctly.
22. When aligning two holes, never insert your fingers or hand. Be careful not to get your fingers caught in a hole.
23. When measuring hydraulic pressure, check that the measuring tool is correctly assembled before taking any measurements.
24. Take care when removing or installing the tracks of track-type machines.
When removing the track, the track separates suddenly, so never let anyone stand at either end of the track.

FOREWORD

This shop manual has been prepared as an aid to improve the quality of repairs by giving the serviceman an accurate understanding of the product and by showing him the correct way to perform repairs and make judgements. Make sure you understand the contents of this manual and use it to full effect at every opportunity.

This shop manual mainly contains the necessary technical information for operations performed in a service workshop.

For ease of understanding, the manual is divided into chapters for each main group of components; these chapters are further divided into the following sections.

STRUCTURE AND FUNCTION

This section explains the structure and function of each component. It serves not only to give an understanding of the structure, but also serves as reference material for troubleshooting.

TESTING AND ADJUSTING

This section explains checks to be made before and after performing repairs, as well as adjustments to be made at completion of the checks and repairs.

Troubleshooting charts correlating "Problems" to "Causes" are also included in this section.

DISASSEMBLY AND ASSEMBLY

This section explains the order to be followed when removing, installing, disassembling or assembling each component, as well as precautions to be taken for these operations.

MAINTENANCE STANDARD

This section gives the judgement standards when inspecting disassembled parts.

NOTICE

The specifications contained in this shop manual are subject to change at any time and without any advance notice. Contact your KOMATSU distributor for the latest information.

HOW TO READ THE SHOP MANUAL

VOLUMES

Shop manuals are issued as a guide to carrying out repairs. They are divided as follows:

- Chassis volume:** Issued for every machine model
- Engine volume:** Issued for each engine series
- Electrical volume** : } Each issued as one
- Attachments volume** : } volume to cover all models

These various volumes are designed to avoid duplicating the same information. Therefore to deal with all repairs for any model, it is necessary that chassis, engine, electrical and attachment volumes are ready.

DISTRIBUTION AND UPDATING

Any additions, amendments or other changes will be sent to KOMATSU distributors. Get the most up-to-date information before you start any work.

FILING METHOD

- See the page number on the bottom of the page. File the pages in correct order.
- Following examples show how to read the page number.

Example 1 (Chassis volume):

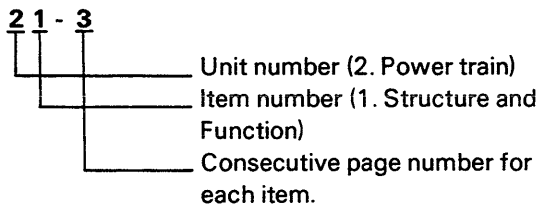

Example 2 (Engine volume):

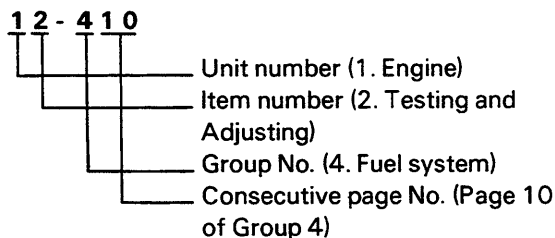

- Additional pages: Additional pages are indicated by a hyphen (-) and number after the page number. File as in the example.

Example:



REVISED EDITION MARK (① ② ③....)

When a manual is revised, an edition mark is recorded on the bottom outside corner of the pages.

REVISIONS

Revised pages are shown at the LIST OF REVISED PAGES on the between the title page and SAFETY page.

SYMBOLS

So that the shop manual can be of ample practical use, important places for safety and quality are marked with the following symbols.

Symbol	Item	Remarks
	Safety	Special safety precautions are necessary when performing the work.
		Extra special safety precautions are necessary when performing the work because it is under internal pressure.
	Caution	Special technical precautions or other precautions for preserving standards are necessary when performing the work.
	Weight	Weight of parts or systems. Caution necessary when selecting hoisting wire, or when working posture is important, etc.
	Tightening torque	Places that require special attention for the tightening torque during assembly.
	Coat	Places to be coated with adhesives and lubricants etc.
	Oil, water	Places where oil, water or fuel must be added, and the capacity.
	Drain	Places where oil or water must be drained, and quantity to be drained.

HOISTING INSTRUCTIONS

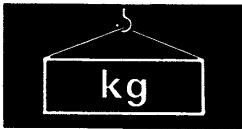

! Heavy parts (25 kg or more) must be lifted with a hoist etc. In the **Disassembly and Assembly** section, every part weighing 25 kg or more is indicated clearly with the symbol kg

1. If a part cannot be smoothly removed from the machine by hoisting, the following checks should be made:
 - Check for removal of all bolts fastening the part to the relative parts.
 - Check for existence of another part causing interference with the part to be removed.

2. Wire ropes

- 1) Use adequate ropes depending on the weight of parts to be hoisted, referring to the table below:

Wire ropes (Standard "Z" or "S" twist ropes without galvanizing)	
Rope diameter (mm)	Allowable load (tons)
10	1.0
11.2	1.4
12.5	1.6
14	2.2
16	2.8
18	3.6
20	4.4
22.4	5.6
30	10.0
40	18.0
50	28.0
60	40.0

The allowable load value is estimated to be one-sixth or one-seventh of the breaking strength of the rope used.

- 2) Sling wire ropes from the middle portion of the hook.

Slinging near the edge of the hook may cause the rope to slip off the hook during hoisting, and a serious accident can result. Hooks have maximum strength at the middle portion.

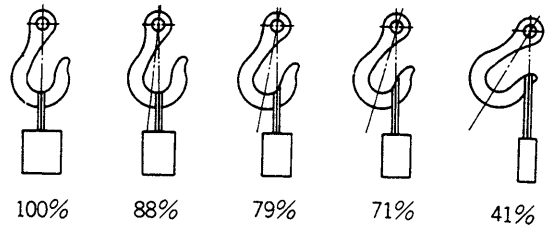

FS0064

- 3) Do not sling a heavy load with one rope alone, but sling with two or more ropes symmetrically wound on to the load.

! Slinging with one rope may cause turning of the load during hoisting, untwisting of the rope, or slipping of the rope from its original winding position on the load, which can result in a dangerous accident.

- 4) Do not sling a heavy load with ropes forming a wide hanging angle from the hook.

When hoisting a load with two or more ropes, the force subjected to each rope will increase with the hanging angles. The table below shows the variation of allowable load (kg) when hoisting is made with two ropes, each of which is allowed to sling up to 1000 kg vertically, at various hanging angles.

When two ropes sling a load vertically, up to 2000 kg of total weight can be suspended. This weight becomes 1000 kg when two ropes make a 120° hanging angle. On the other hand, two ropes are subjected to an excessive force as large as 4000 kg if they sling a 2000 kg load at a lifting angle of 150°.

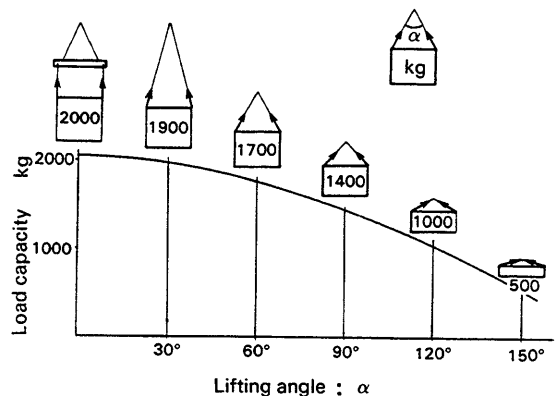

FS0065



STANDARD TIGHTENING TORQUE



STANDARD TIGHTENING TORQUE

1. STANDARD TIGHTENING TORQUE OF BOLTS AND NUTS

The following charts give the standard tightening torques of bolts and nuts. Exceptions are given in sections of "Disassembly and Assembly".

Thread diameter of bolt (mm)	Width across flat (mm)		
		kgm	Nm
6	10	1.35±0.15	13.2±1.4
8	13	3.2±0.3	31.4±2.9
10	17	6.7±0.7	65.7±6.8
12	19	11.5±1.0	112±9.8
14	22	18.0±2.0	177±19
16	24	28.5±3	279±29
18	27	39±4	383±39
20	30	56±6	549±58
22	32	76±8	745±78
24	36	94.5±10	927±98
27	41	135±15	1320±140
30	46	175±20	1720±190
33	50	225±25	2210±240
36	55	280±30	2750±290
39	60	335±35	3280±340

This torque table does not apply to the bolts with which nylon packings or other non-ferrous metal washers are to be used, or which require tightening to otherwise specified torque.

★ Nm (newton meter): 1Nm ≅ 0.1 kgm

2. TIGHTENING TORQUE OF SPLIT FLANGE BOLTS

Use these torques for split flange bolts.

Thread diameter of bolt (mm)	Width across flats (mm)	Tightening torque	
		kgm	Nm
10	14	6.7±0.7	65.7±6.8
12	17	11.5±1	112±9.8
16	22	28.5±3	279±29

STANDARD TIGHTENING TORQUE



3. TIGHTENING TORQUE FOR NUTS OF FLARED

Use these torques for nut part of flared.

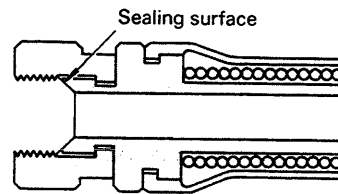

FS0068

Thread diameter of nut part (mm)	Width across flats of nut part (mm)	Tightening torque	
		kgm	Nm
14	19	2.5 ± 0.5	24.5 ± 4.9
18	24	5 ± 2	49 ± 19.6
22	27	8 ± 2	78.5 ± 19.6
24	32	14 ± 3	137.3 ± 29.4
30	36	18 ± 3	176.5 ± 29.4
33	41	20 ± 5	196.1 ± 49
36	46	25 ± 5	245.2 ± 49
42	55	30 ± 5	294.2 ± 49

COATING MATERIALS

The recommended coating materials prescribed in Komatsu Shop Manuals are listed below.

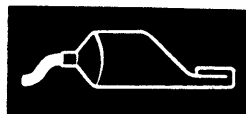

Nomenclature	Komatsu code	Applications
Adhesives	LT-1A	Used to apply rubber pads, rubber gaskets, and cork plugs.
	LT-1B	Used to apply resin, rubber, metallic and non-metallic parts when a fast, strong seal is needed.
	LT-2*	Preventing bolts, nuts and plugs from loosening and leaking oil.
	LT-3	Provides an airtight, electrically insulating seal. Used for aluminum surfaces.
Liquid gasket	LG-1	Used with gaskets and packings to increase sealing effect.
	LG-3	Heat-resistant gasket for precombustion chambers and exhaust piping.
	LG-4	Used by itself on mounting surfaces on the final drive and transmission cases. (Thickness after tightening: 0.07 – 0.08 mm)
	LG-5	Used by itself to seal grease fittings, tapered screw fittings and tapered screw fittings in hydraulic circuits of less than 50 mm in diameter.
Antifriction compound (Lubricant including molybdenum disulfide)	LM-P	Applied to bearings and taper shafts to facilitate press-fitting and to prevent sticking, burning or rusting.
Grease (Lithium grease)	G2-LI	Applied to bearings, sliding parts and oil seals for lubrication, rust prevention and facilitation of assembling work.
Vaseline	—	Used for protecting battery electrode terminals from corrosion.

*LT-2 is also called LOCTITE in the shop manuals.



ELECTRIC WIRE CODE

In the wiring diagrams, various colors and symbols are employed to indicate the thickness of wires. This wire code table will help you understand WIRING DIAGRAMS.

Example: 5WB indicates a cable having a nominal number 5 and white coating with black stripe.

CLASSIFICATION BY THICKNESS

Nominal number	Copper wire			Cable O.D. (mm)	Current rating (A)	Applicable circuit
	Number strands	Dia. of strands (mm)	Cross section (mm ²)			
0.85	11	0.32	0.88	2.4	12	Starting, lighting, signal etc.
2	26	0.32	2.09	3.1	20	Lighting, signal etc.
5	65	0.32	5.23	4.6	37	Charging and signal
15	84	0.45	13.36	7.0	59	Starting (Glow plug)
40	85	0.80	42.73	11.4	135	Starting
60	127	0.80	63.84	13.6	178	Starting
100	217	0.80	109.1	17.6	230	Starting

CLASSIFICATION BY COLOR AND CODE

Priority	Classification	Circuits							
		Charging	Ground	Starting	Lighting	Instrument	Signal	Other	
1	Primary	Code	W	B	B	R	Y	G	L
		Color	White	Black	Black	Red	Yellow	Green	Blue
2	Auxiliary	Code	WR	—	BW	RW	YR	GW	LW
		Color	White & Red	—	Black & White	Red & White	Yellow & Red	Green & White	Blue & White
3	Auxiliary	Code	WB	—	BY	RB	YB	GR	LR
		Color	White & Black	—	Black & Yellow	Red & Black	Yellow & Black	Green & Red	Blue & Red
4	Auxiliary	Code	WL	—	BR	RY	YG	GY	LY
		Color	White & Blue	—	Black & Red	Red & Yellow	Yellow & Green	Green & Yellow	Blue & Yellow
5	Auxiliary	Code	WG	—	—	RG	YL	(GB)	(LB)
		Color	White & Green	—	—	Red & Green	Yellow & Blue	(Green & Black)	(Blue & Black)
6	Auxiliary	Code	—	—	—	RL	YW	(GL)	—
		Color	—	—	—	Red & Blue	Yellow & White	(Green & Blue)	—

SHOP MANUAL

D40·41A,P-3

SERIAL NO. D40A, P-3 6001 and up
SERIAL NO. D41A, P-3 6001 and up

01 GENERAL

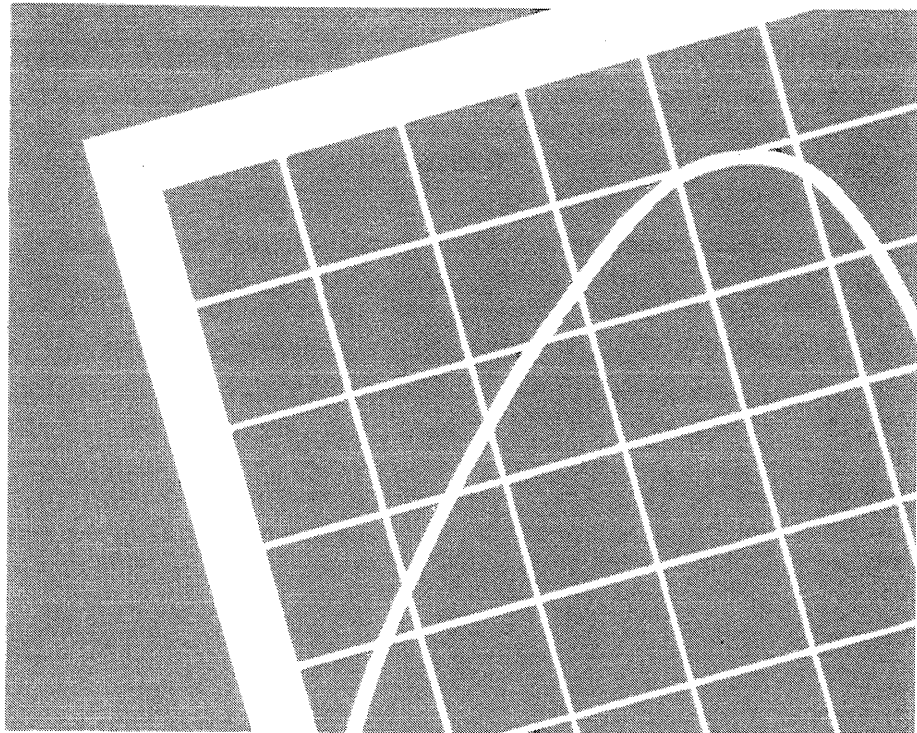

GENERAL

General view	01- 2
Assembly drawing	01- 5
Specifications	01- 6-4
Engine assembly drawing	01- 9
Engine specifications	01-11
Weight table	01-12
Table of fuel, coolant and lubricants	01-14

GENERAL VIEW

D40A-3

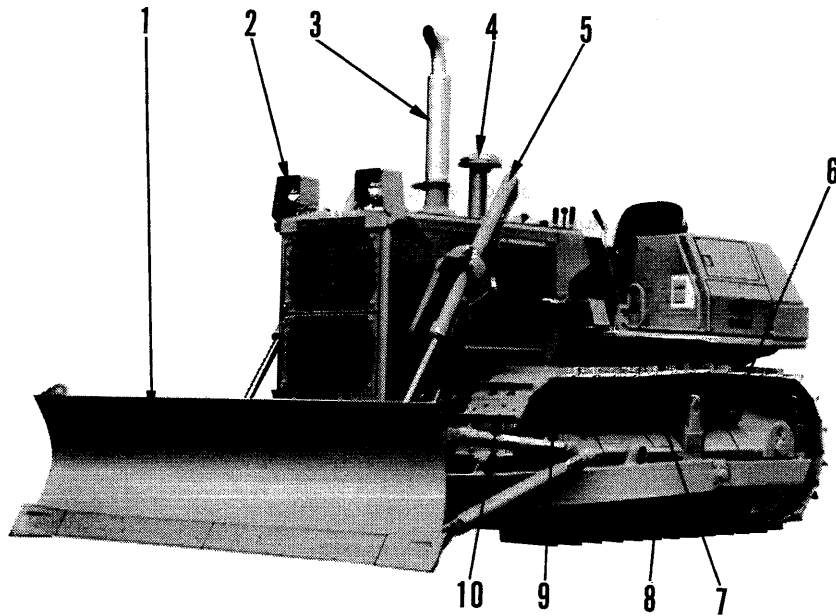

- 1. Blade
- 2. Head lamp
- 3. Exhaust pipe
- 4. Cap for air cleaner
- 5. Lift cylinder
- 6. Sprocket
- 7. Carrier roller
- 8. Track roller
- 9. Idler
- 10. Track shoe

124P001

D40P-3

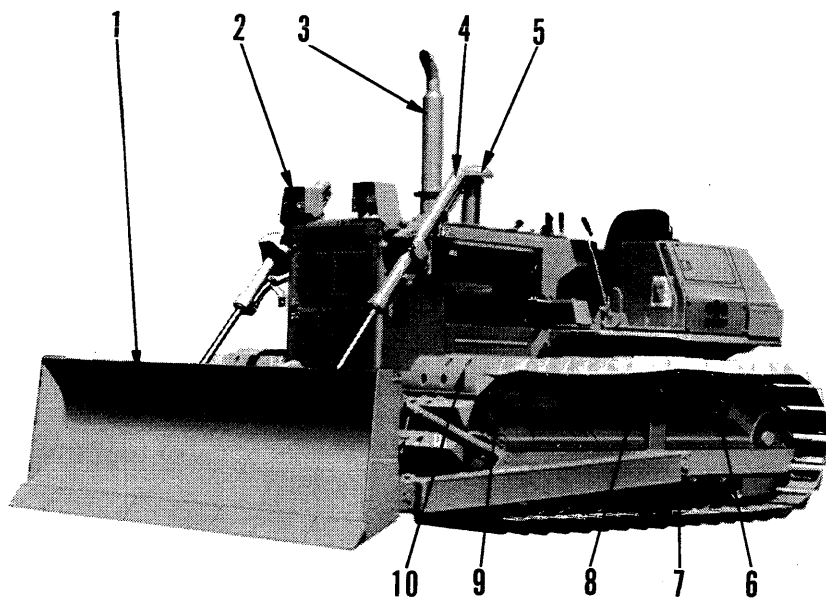

- 1. Blade
- 2. Head lamp
- 3. Exhaust pipe
- 4. Lift cylinder
- 5. Cap for air cleaner
- 6. Sprocket
- 7. Track roller
- 8. Carrier roller
- 9. Idler
- 10. Track shoe

124P002

D41A-3

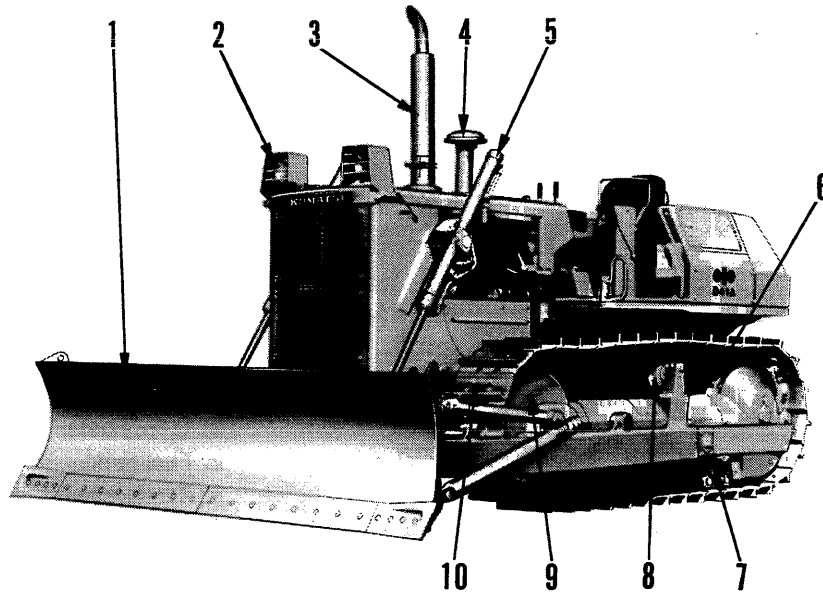

- 1. Blade
- 2. Head lamp
- 3. Exhaust pipe
- 4. Cap for air cleaner
- 5. Lift cylinder
- 6. Sprocket
- 7. Track roller
- 8. Carrier roller
- 9. Idler
- 10. Track shoe

124P003

D41P-3

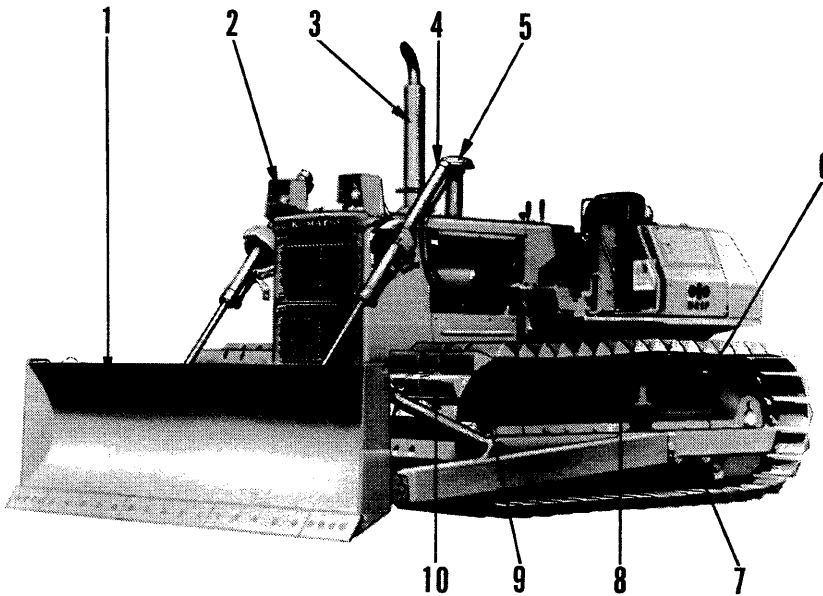

- 1. Blade
- 2. Head lamp
- 3. Exhaust pipe
- 4. Lift cylinder
- 5. Cap for air cleaner
- 6. Sprocket
- 7. Track roller
- 8. Carrier roller
- 9. Idler
- 10. Track shoe

124P004

D41A-3A

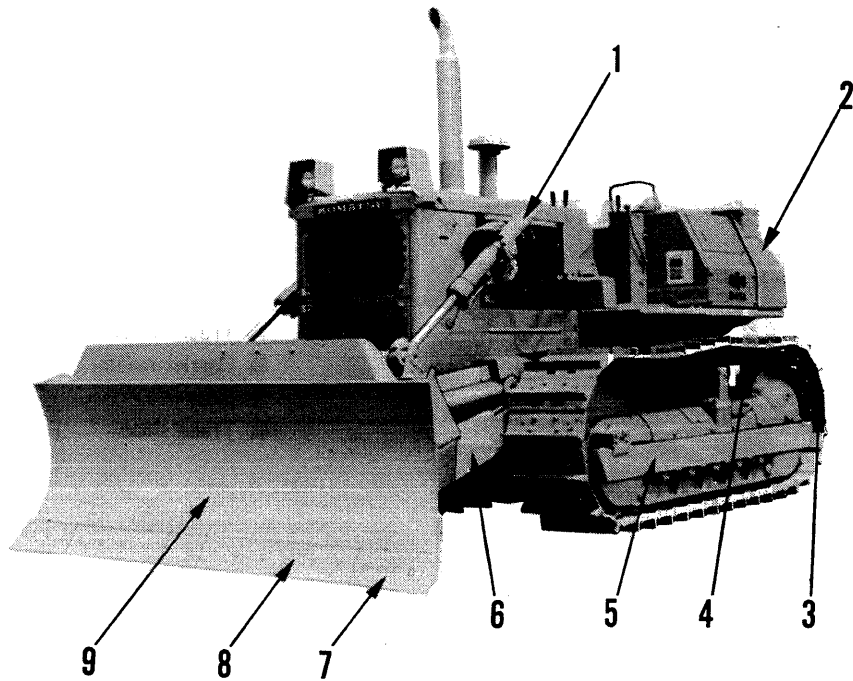

- 1. Lift cylinder
- 2. Fuel tank
- 3. Track shoe
- 4. Sprocket
- 5. Track frame
- 6. Blade frame
- 7. End bit
- 8. Cutting edge
- 9. Blade

124P005

ASSEMBLY DRAWING

D40A-3

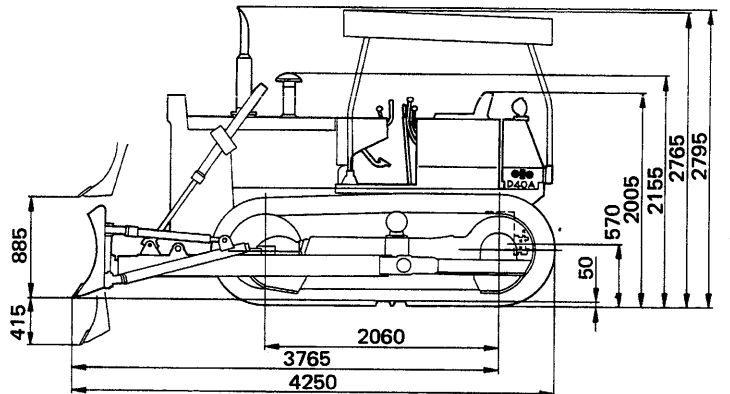
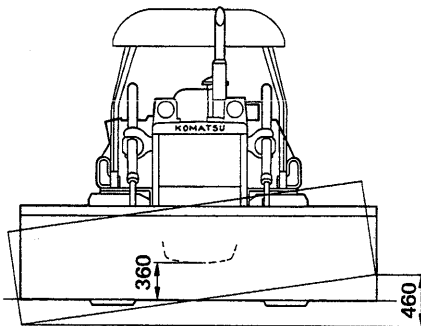
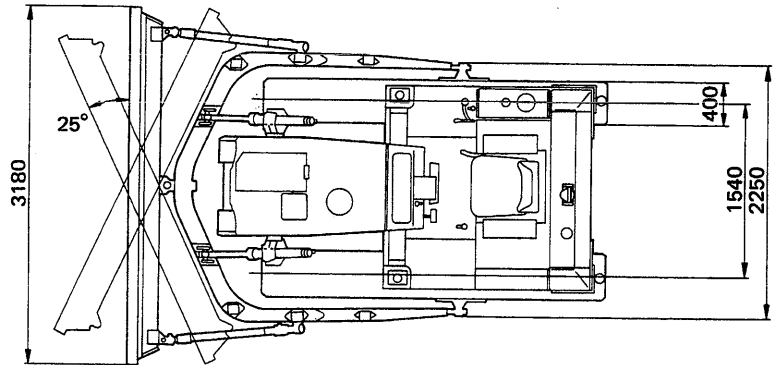

D40P-3

F120C001

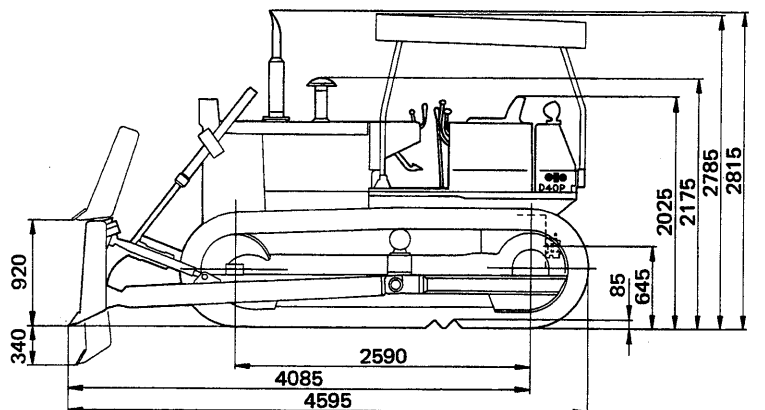
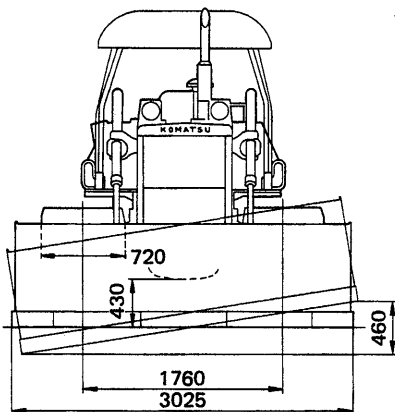

F120C002

D40-41 A,P-3

01-5

D41A-3

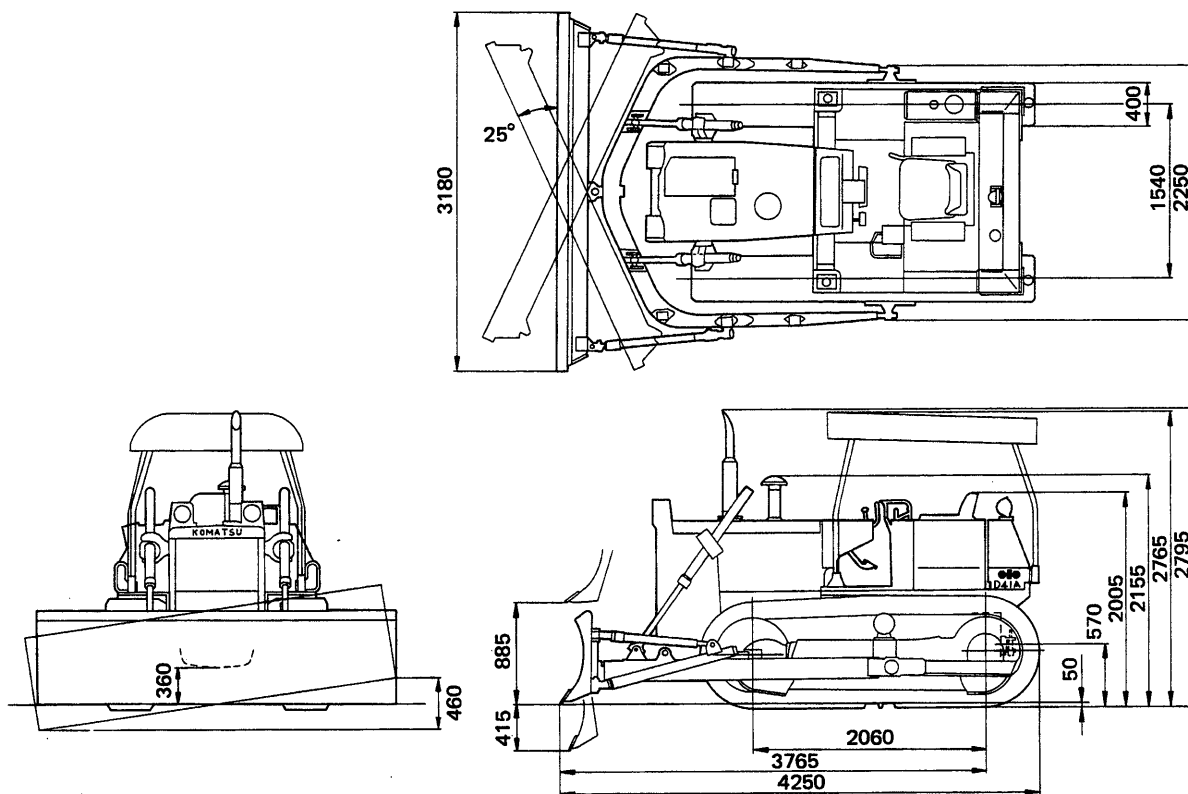

D41P-3

F I 20C003

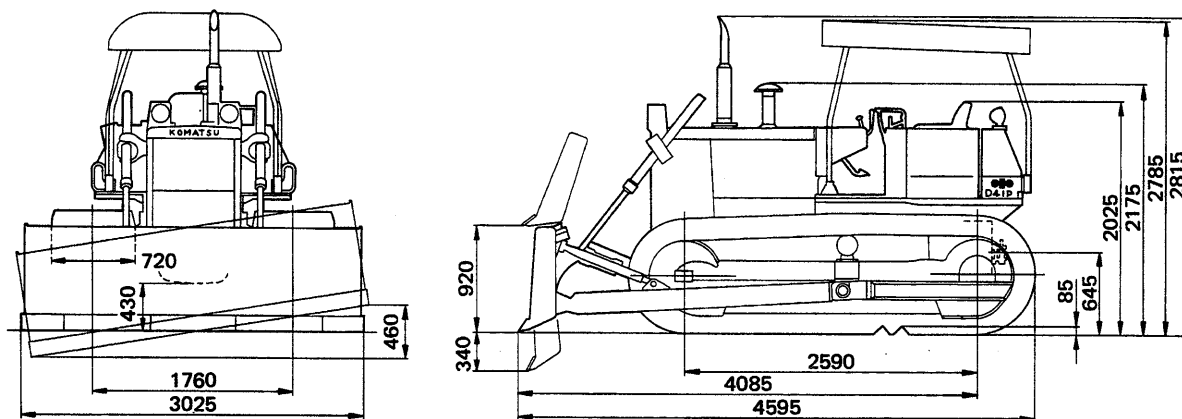

F I 20C004