

Operation & Maintenance Manual



D85EX-15

D85PX-15

BULLDOZER

SERIAL NUMBER

D85EX-15 - 10001 and up

D85PX-15 - 1001 and up



WARNING

Unsafe use of this machine may cause serious injury or death. Operators and maintenance personnel must read this manual before operating or maintaining this machine. This manual should be kept inside the cab for reference and periodically reviewed by all personnel who will come into contact with the machine.

KOMATSU

FOREWORD

FOREWORD

This manual provides rules and guidelines which will help you use this machine safely and effectively. The precautions in this manual must be followed at all times when performing operation and maintenance. Most accidents are caused by the failure to follow fundamental safety rules for the operation and maintenance of machines. Accidents can be prevented by knowing beforehand conditions that may cause a hazard when performing operation and maintenance.

WARNING

Operators and maintenance personnel must always do as follows before beginning operation or maintenance.

- **Always be sure to read and understand this manual thoroughly before performing operation and maintenance.**
- **Read the safety messages given in this manual and the safety labels affixed to the machine thoroughly and be sure that you understand them fully.**

Keep this manual at the storage location for the Operation and Maintenance Manual given below, and have all personnel read it periodically.

If this manual has been lost or has become dirty and cannot be read, request a replacement manual immediately from Komatsu or your Komatsu distributor.

If you sell the machine, be sure to give this manual to the new owners together with the machine.

Komatsu delivers machines that comply with all applicable regulations and standards of the country to which it has been shipped. If this machine has been purchased in another country or purchased from someone in another country, it may lack certain safety devices and specifications that are necessary for use in your country. If there is any question about whether your product complies with the applicable standards and regulations of your country, consult Komatsu or your Komatsu distributor before operating the machine.

Location to Keep Operation & Maintenance Manual
In Door Pocket Inside of Cab Door

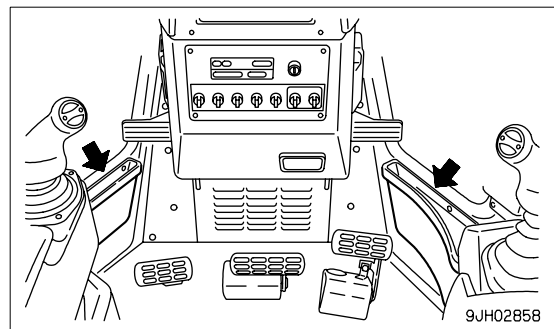

SAFETY INFORMATION

To enable you to use this machine safely, safety precautions and labels are given in this manual and affixed to the machine to give explanations of situations involving potential hazards and of the methods of avoiding such situations.

Signal words

The following signal words are used to inform you that there is a potential hazardous situation that may lead to personal injury or damage.

In this manual and on machine labels, the following signal words are used to express the potential level of hazard.



Indicates an imminently hazardous situation which, if not avoided, will result in death or serious injury.



Indicates a potentially hazardous situation which, if not avoided, could result in death or serious injury.



Indicates a potentially hazardous situation which, if not avoided, may result in minor or moderate injury. This word is used also to alert against unsafe practices that may cause property damage.

Example of safety message using signal word



When standing up from the operator's seat, always place the safety lock lever in the LOCK position. If you accidentally touch the control levers when they are not locked, this may cause a serious injury or death.

Other signal words

In addition to the above, the following signal words are used to indicate precautions that should be followed to protect the machine or to give information that is useful to know.

NOTICE

This word is used for precautions that must be taken to avoid actions which could shorten the life of the machine.

REMARKS

This word is used for information that is useful to know.

- Safety labels

Safety labels are affixed to the machine to inform the operator or maintenance worker on the spot when carrying out operation or maintenance of the machine that may involve hazard.

This machine uses “Safety labels using words” and “Safety labels using pictograms” to indicate safety procedures.

Example of safety label using words

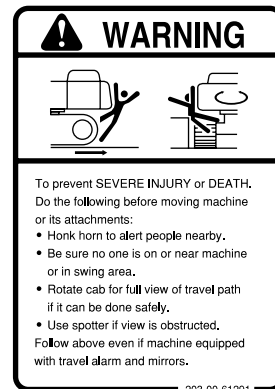

Part No.

Safety labels using pictogram

Safety pictograms use a picture to express a level of hazardous condition equivalent to the signal word. These safety pictograms use pictures in order to let the operator or maintenance worker understand the level and type of hazardous condition at all times. Safety pictograms show the type of hazardous condition at the top or left side, and the method of avoiding the hazardous condition at the bottom or right side. In addition, the type of hazardous condition is displayed inside a triangle and the method of avoiding the hazardous condition is shown inside a circle.



Part No

Komatsu cannot predict every circumstance that might involve a potential hazard in operation and maintenance. Therefore, the safety messages in this manual and on the machine may not include all possible safety precautions.

If any procedures or actions not specifically recommended or allowed in this manual are used, it is your responsibility to take the necessary steps to ensure safety.

In no event should you engage in prohibited uses or actions described in this manual.

The explanations, values, and illustrations in this manual were prepared based on the latest information available at that time. Continuing improvements in the design of this machine can lead to changes in detail which may not be reflected in this manual. Consult Komatsu or your Komatsu distributor for the latest available information of your machine or for questions regarding information in this manual.

The numbers in circles in the illustrations correspond to the numbers in () in the text. (For example: ① -> (1))

Noise emission levels

Two labels indicating the machine noise level are affixed on the machine.

- Sound pressure level at the operator's station, measured according to ISO6396 (Dynamic test method, simulated working cycle)
- Sound power level emitted by the machine, measured according to ISO 6395 (Dynamic test method, simulated working cycle). This is the guaranteed value as specified in European directive 2000/14/EC.

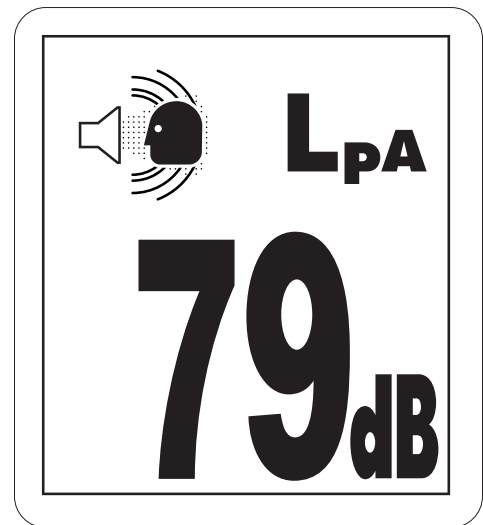

Vibration levels

When used for its intended purpose, levels of vibration for the earth-moving machine transmitted from the operator's seat are lower than or equal to the tested vibrations for the relative machinery class in compliance with ISO 7096.

- If equipped with air suspension seat

The actual acceleration value for the hands and arms is less than or equal to 2.5 m/s². The actual acceleration value for the body is less than or equal to 0.5 m/s².

- If equipped with mechanical suspension seat

The actual acceleration value for the hands and arms is less than or equal to 2.5 m/s². The actual acceleration value for the body is 0.52 m/s².

These values were determined using a representative machine and measured during the typical operating condition indicated below according to the measurement procedures that are defined in the standards ISO 2631/1 and ISO 5349.

Operating condition:

(WHEEL LOADER:) V-shape loading

(HYDRAULIC EXCAVATORS:) Excavating (Digging-loading-rotating-unloading-rotating)

(TRACTOR DOZER:) Dozing and spreading material through forward/reversing motion

(Rigid/Articulate dumper:) Work cycle (including waiting, travelling, loading, travelling with load, unloading, and travelling without load)

Guide to Reduce Vibration Levels on Machine

The following guides can help an operator of this machine to reduce the whole body vibration levels:

1. Use the correct equipment and attachments.
2. Maintain the machine according to this manual
 - Tire pressures (for wheeled machines), tension of crawler (for crawler machines)
 - Brake and steering systems
 - Controls, hydraulic system and linkages
3. Keep the terrain where the machine is working and traveling in good condition
 - Remove any large rocks or obstacles
 - Fill any ditches and holes
 - Site manager should provide machine operators with machine and schedule time to maintain terrain conditions
4. Use a seat that meets ISO 7096 and keep the seat maintained and adjusted
 - Adjust the seat and suspension for the weight and size of the operator
 - Wear seat belt
 - Inspect and maintain the seat suspension and adjustment mechanisms
5. Steer, brake, accelerate, shift gears (for wheeled machines), and move the attachment levers and pedals slowly so that the machine moves smoothly
6. Adjust the machine speed and travel path to minimize the vibration level
 - When pushing with bucket or blade, avoid sudden loading; load gradually
 - Drive around obstacles and rough terrain conditions
 - Slow down when it is necessary to go over rough terrain
 - Make the curve radius of traveling path as large as possible
 - Travel at low speed when traveling around sharp curves
7. Minimize vibrations for long work cycle or long distance traveling
 - Reduce speed to prevent bounce
 - Transport machines long distances between worksites
8. The following guidelines can be effective to minimize risks of low back pain
 - Operate the machine only when you are in good health.
 - Provide breaks to reduce long periods of sitting in the same posture
 - Do not jump down from the cab or machine
 - Do not repeatedly handle and lift loads

INTRODUCTION

This Komatsu machine is designed to be used mainly for the following work:

- Dozing
- Cutting into hard or frozen ground or ditching
- Felling trees, removing stumps
- Pushing
- Ripping

For further details, see "WORK POSSIBLE USING BULLDOZER (3-92)".

FRONT/REAR, LEFT/RIGHT DIRECTIONS OF MACHINE

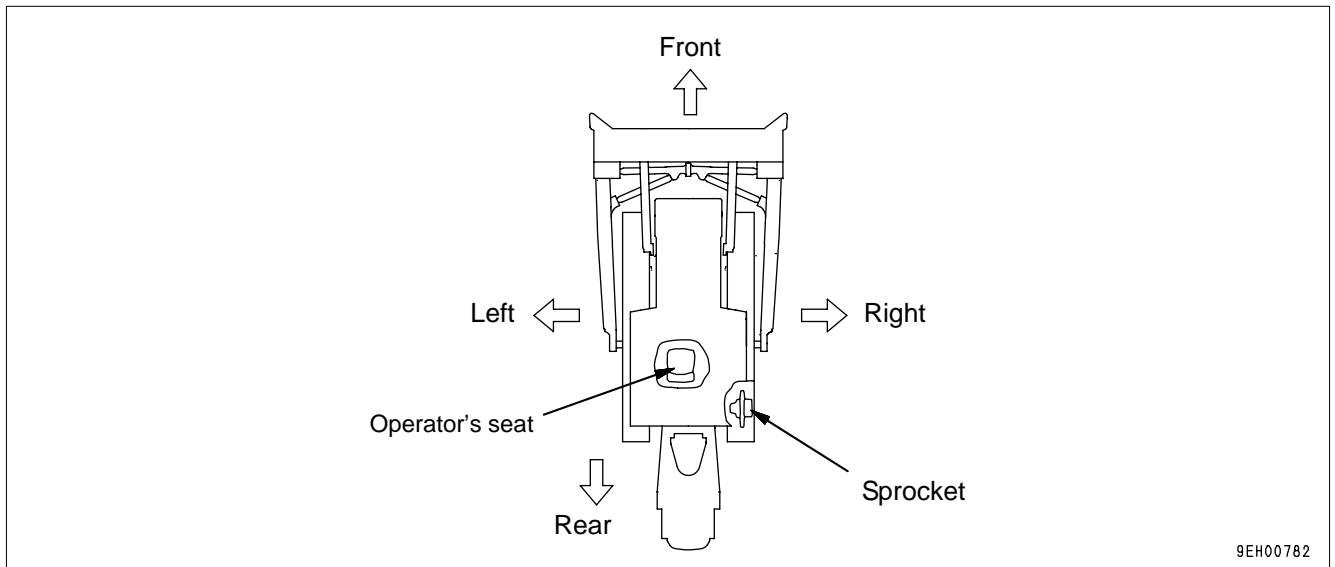

In this manual, the terms front, rear, left, and right refer to the travel direction as seen from the operator's seat when the operator's seat is facing the front and the sprocket is at the rear of the machine.

NECESSARY INFORMATION

When requesting service or ordering replacement parts, please inform your Komatsu distributor of the following items.

MACHINE SERIAL NO. PLATE AND POSITION

Under the front of the console box on the right side of the operator's seat.

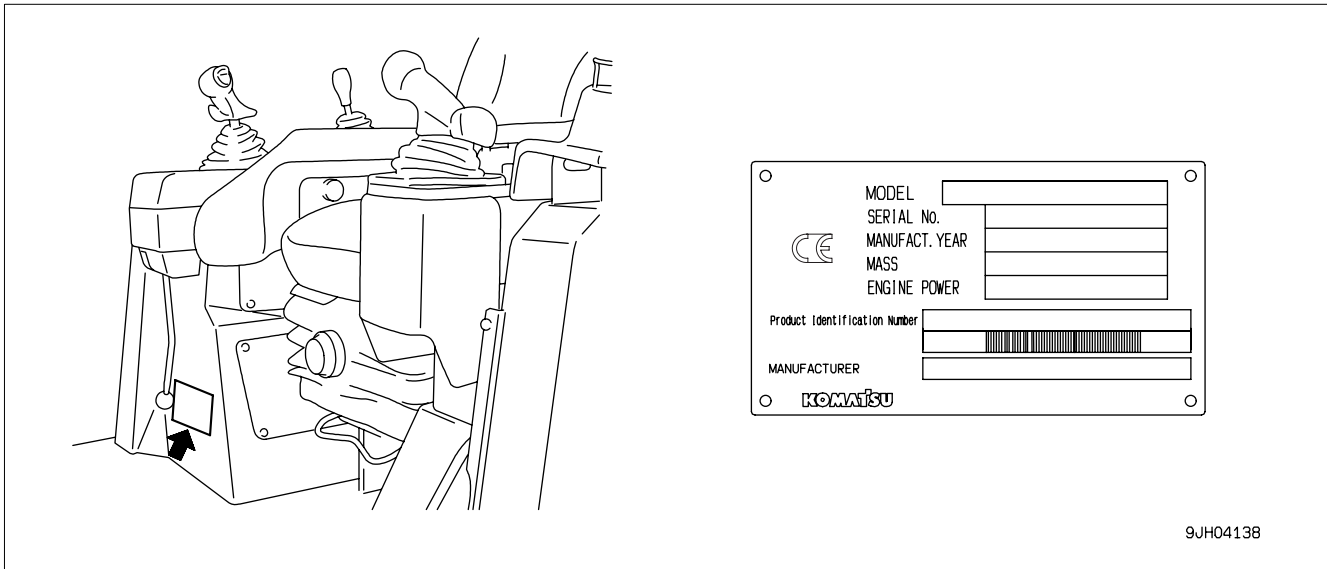

ENGINE SERIAL NO. PLATE AND POSITION

This is at the rear of the starting motor on the rights side of the engine.
(The EMISSION CONTROL INFORMATION LABEL is at the front surface of the engine oil filler on the left side of the engine.)

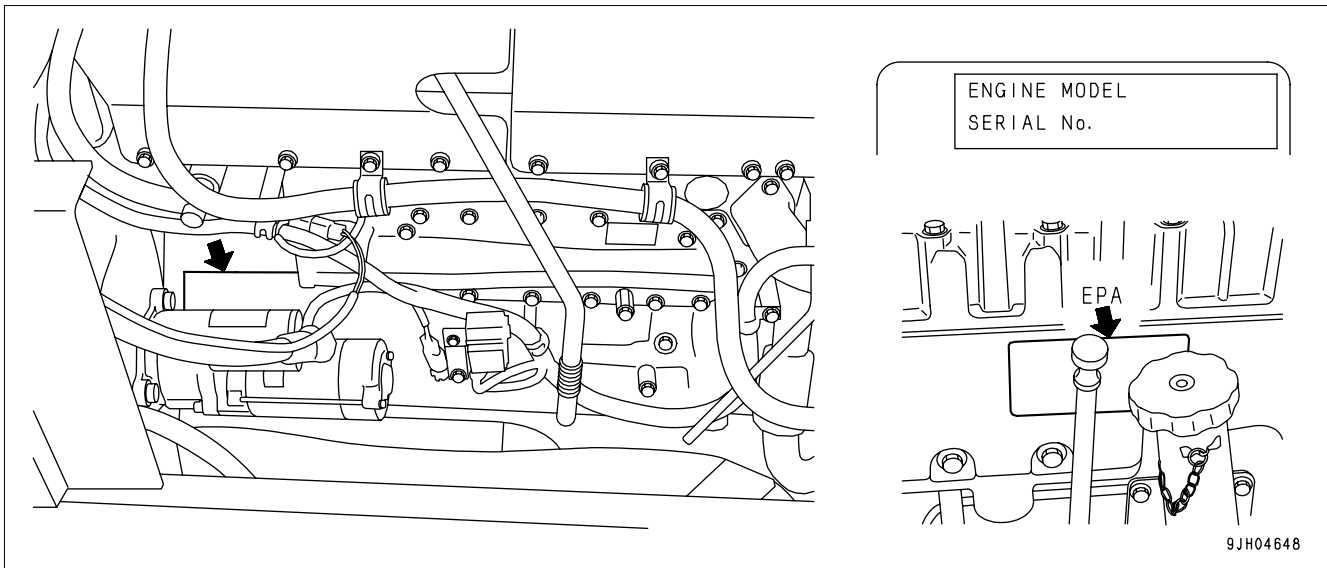

EPA: Environmental Protection Agency, U.S.A.

BLADE SERIAL NO. PLATE POSITION

This is located at the upper right of blade back surface.

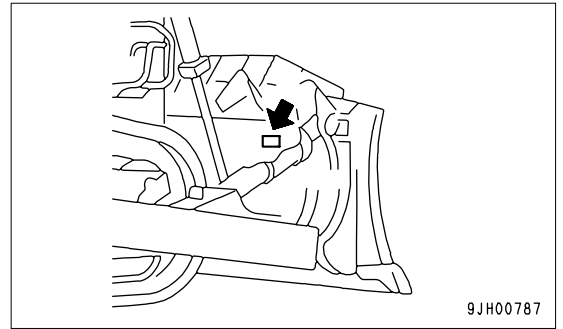

RIPPER SERIAL NO. PLATE POSITION

This is located at the left side surface of ripper beam.

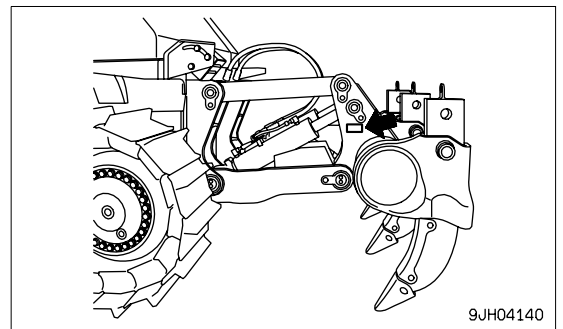

ROPS, FOPS NO. PLATE POSITION

This is located at the top left.

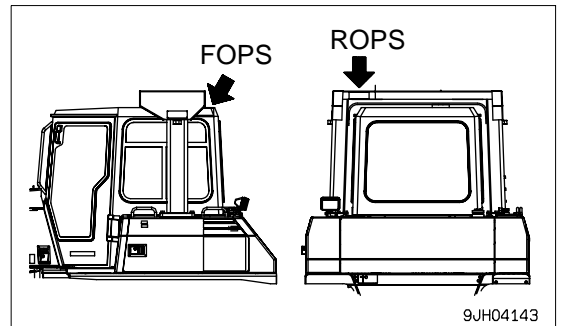

POSITION OF SERVICE METER

On top of the machine monitor

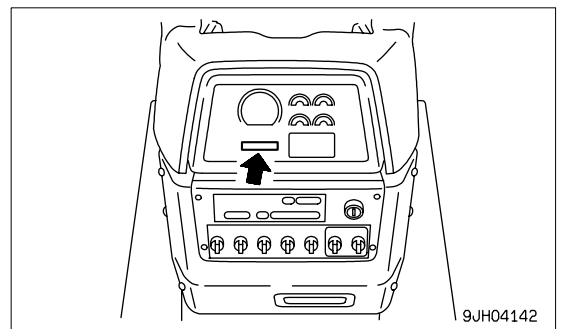

TABLE OF ENTER SERIAL NO. AND DISTRIBUTOR

Machine serial No.

Engine serial No.

Product Identification Number

Manufacturers name:	KOMATSU LTD.
Address:	3-6 Akasaka Minato-ku, 101 Tokyo Japan

Distributor
Address

Phone

Service personnel for your
machine:

MACHINE SERIAL NUMBER PLATE

Valid until 31 December 2003

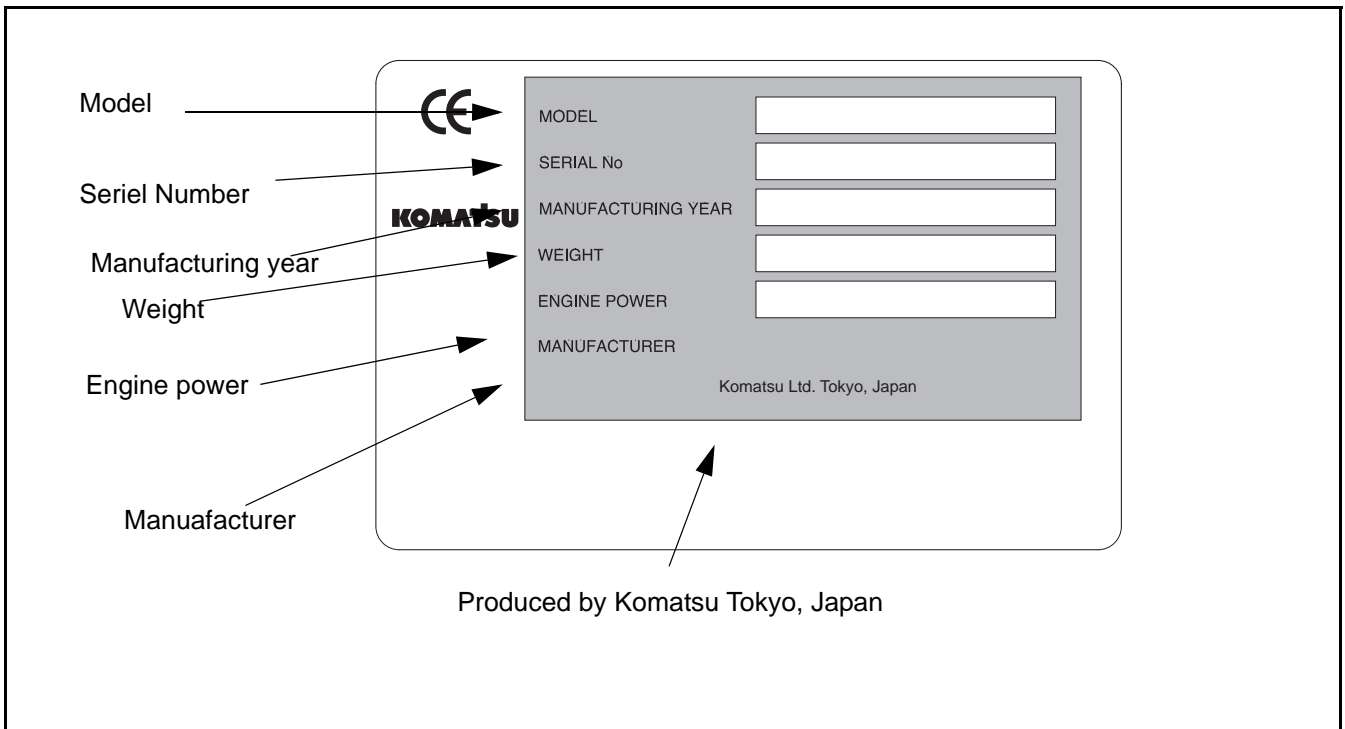

Valid as of 1 January 2004

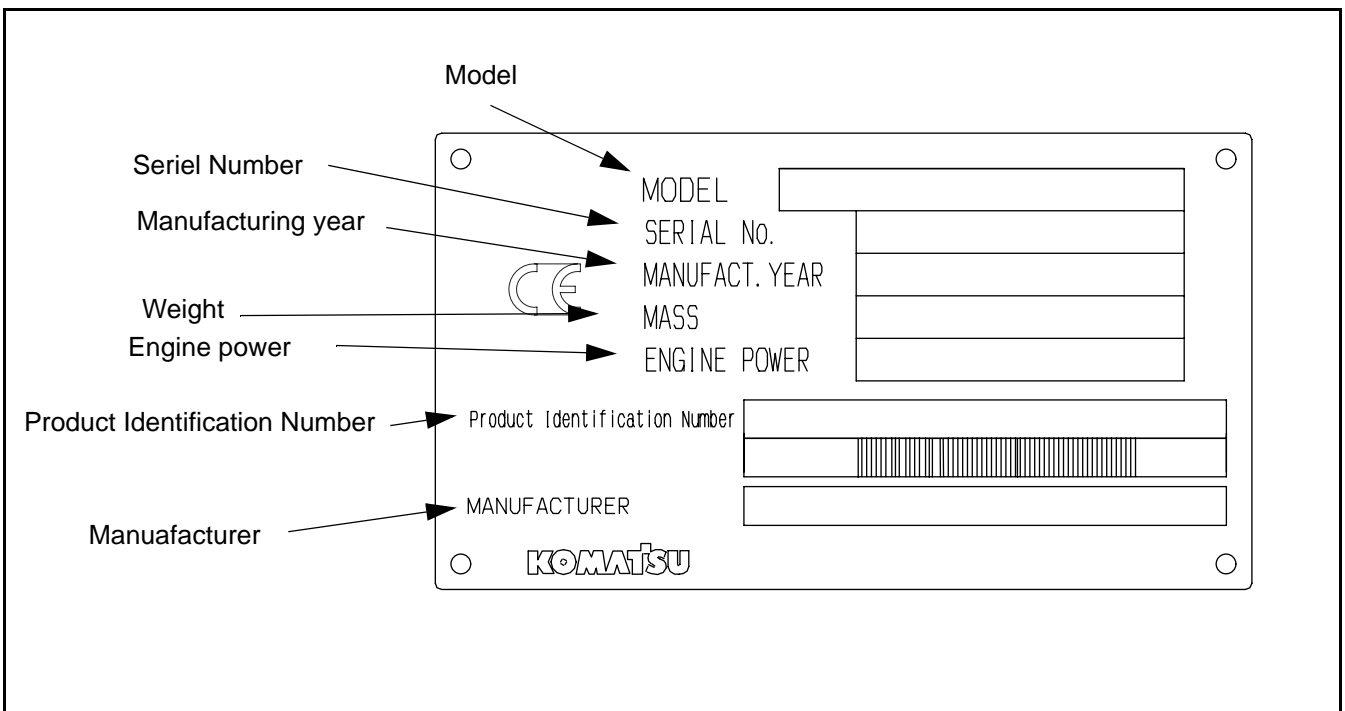

CONTENTS

FOREWORD

FOREWORD	1-2
SAFETY INFORMATION	1-3
Noise emission levels	1-5
Vibration levels.....	1-5
Guide to Reduce Vibration Levels on Machine.....	1-6
INTRODUCTION	1-7
FRONT/REAR, LEFT/RIGHT DIRECTIONS OF MACHINE	1-7
NECESSARY INFORMATION	1-8
MACHINE SERIAL NO. PLATE AND POSITION	1-8
ENGINE SERIAL NO. PLATE AND POSITION	1-8
BLADE SERIAL NO. PLATE POSITION	1-9
RIPPER SERIAL NO. PLATE POSITION.....	1-9
ROPS, FOPS NO. PLATE POSITION	1-9
POSITION OF SERVICE METER	1-9
TABLE OF ENTER SERIAL NO. AND DISTRIBUTOR	1-10
MACHINE SERIAL NUMBER PLATE.....	1-11

SAFETY

SAFETY	2-2
SAFETY LABELS	2-4
POSITIONS OF SAFETY PICTOGRAMS	2-4
SAFETY LABELS	2-5
GENERAL PRECAUTIONS	2-9
PRECAUTIONS FOR OPERATION	2-16
BEFORE STARTING ENGINE	2-16
OPERATION.....	2-17
TRANSPORTATION.....	2-20
BATTERY	2-20
TOWING	2-22
PRECAUTIONS FOR MAINTENANCE	2-23

OPERATION

GENERAL VIEW	3-2
---------------------------	-----

GENERAL VIEW OF MACHINE	3-2
GENERAL VIEW OF CONTROLS AND GAUGES.....	3-3
EXPLANATION OF COMPONENTS.....	3-5
FRONT PANEL.....	3-5
CHECK MONITOR GROUP	3-7
CAUTION MONITOR GROUP	3-8
EMERGENCY CAUTION ITEMS	3-10
METER GROUP	3-12
SWITCH.....	3-16
LAMP	3-19
METHOD OF USING DISPLAY PANEL B (Multi-information)	3-21
SWITCH.....	3-28
CONTROL LEVERS, PEDALS	3-31
DUST INDICATOR	3-36
FUSE BOX.....	3-37
CIRCUIT BREAKER.....	3-38
FUSE CAPACITY AND NAME OF CIRCUIT.....	3-38
FUSIBLE LINK.....	3-39
DOOR OPEN LOCK	3-40
SASH GLASS INTERMEDIATE LOCK.....	3-40
DOOR POCKET	3-41
ASHTRAY	3-41
CAR STEREO, HANDLING	3-42
EXPLANATION OF COMPONENTS.....	3-42
METHOD OF OPERATION	3-47
PRECAUTION WHEN USING.....	3-49
AIR CONDITIONER.....	3-50
GENERAL LOCATIONS AND FUNCTION OF CONTROL PANEL	3-50
METHOD OF OPERATION	3-52
PRECAUTIONS WHEN USING	3-53
SET SO THAT COLD AIR DOES NOT DIRECTLY BLOW ONTO THE GLASS SURFACE	3-53
CHECKS DURING OFF-SEASON	3-53
PROCEDURE FOR REPLACING RECEIVER	3-53
CHECK COMPRESSOR BELT TENSION AND REFRIGERANT (GAS) LEVEL.....	3-54
CLEANING AIR FILTER	3-54
ACCUMULATOR, HANDLING.....	3-54
METHOD OF RELEASING PRESSURE IN OPERATING CIRCUIT ON MACHINE EQUIPPED WITH ACCUMULATOR	3-54
OPERATION.....	3-55
CHECK BEFORE STARTING ENGINE, ADJUST.....	3-55
WALK-AROUND CHECK	3-55
CHECK BEFORE STARTING	3-56
ADJUSTMENT.....	3-65
OPERATIONS AND CHECKS BEFORE STARTING ENGINE.....	3-69
STARTING ENGINE	3-71
NORMAL STARTING	3-71

CONTENTS

STARTING IN COLD WEATHER 3-72

OPERATIONS AND CHECKS AFTER STARTING ENGINE 3-75

 BREAKING IN THE MACHINE 3-75

 NORMAL OPERATION 3-75

 IN COLD AREAS 3-77

STOPPING ENGINE 3-78

CHECK AFTER STOPPING ENGINE 3-78

MOVING MACHINE OFF 3-79

STOPPING MACHINE 3-81

SHIFTING GEAR 3-82

SHIFTING BETWEEN FOEWARD AND REVERSE 3-84

STEERING MACHINE 3-86

 NORMAL TURNING 3-86

 TURNING WHILE DESCENDING A SLOPE 3-87

PRECAUTIONS FOR OPERATION 3-88

 PAY ATTENTION TO GAUGES 3-88

 PERMISSIBLE WATER DEPTH 3-88

 PRECAUTIONS WHEN TRAVELING UP OR DOWN HILLS 3-88

 PRECAUTIONS ON SLOPE 3-88

 METHOD OF USING BRAKES 3-88

 PROHIBITED TO KEEP THE DOOR OPEN DURING OPERATIONS 3-89

 IT IS PROHIBITED TO MODIFY THE CAB GLASS IN ANY WAY THAT WILL OBSTRUCT THE VIEW
 3-89

 PRECAUTIONS FOR BLIND SPOTS CAUSED BY CAB STAY AND ROPS STAY 3-89

PARKING MACHINE 3-89

CHECK AFTER FINISHING WORK 3-91

LOCKING 3-91

WORK POSSIBLE USING BULLDOZER 3-92

 DOZING 3-92

 CUTTING INTO HARD OR FROZEN GROUND OR DITCHING 3-92

 FELLING TREES, REMOVING STUMPS 3-92

 PUSHER OPERATIONS 3-92

 SMOOTHING 3-93

ADJUSTING POSTURE OF WORK EQUIPMENT 3-94

 BLADE ADJUSTMENT 3-94

 However, the more the digging angle is changed, the more the change becomes in the amount of tilt on the
 left and right sides provided by the tilt cylinder. 3-95

 ADJUSTING RIPPER 3-96

TIPS FOR LONGER UNDERCARRIAGE LIFE 3-98

 OPERATION METHOD 3-98

 INSPECTION AND ADJUSTING 3-98

 INSPECTION AND REPAIR 3-99

TRANSPORTATION 3-100

 TRANSPORTATION PROCEDURE 3-100

 LOADING, UNLOADING WORK 3-100

 PRECAUTIONS FOR LOADING 3-100

 METHOD OF LIFTING MACHINE 3-101

PRECAUTIONS FOR TRANSPORTATION	3-102
TRAVELING ON ROADS	3-102
REMOVAL OF CAB	3-102
INSTALLATION OF CAB	3-103
INSTALLATION OF ROPS	3-103
COLD WEATHER OPERATION	3-104
PRECAUTIONS FOR LOW TEMPERATURE	3-104
FUEL AND LUBRICANTS	3-104
COOLANT	3-104
BATTERY	3-104
AFTER COMPLETION OF WORK	3-105
AFTER COLD WEATHER	3-105
LONG-TERM STORAGE	3-106
BEFORE STORAGE	3-106
DURING STORAGE	3-106
AFTER STORAGE	3-106
TROUBLESHOOTING	3-107
AFTER RUNNING OUT OF FUEL	3-107
PROCEDURE FOR BLEEDING AIR	3-107
METHOD OF TOWING MACHINE	3-108
IF BATTERY IS DISCHARGED	3-109
STARTING ENGINE WITH BOOSTER CABLE	3-109
OTHER TROUBLE	3-112
ELECTRICAL SYSTEM	3-112
MONITOR PANEL	3-113
CHASSIS	3-114
ENGINE	3-116
 MAINTENANCE	
GUIDES TO MAINTENANCE	4-2
OUTLINES OF SERVICE	4-5
HANDLING OIL, FUEL, COOLANT, AND PERFORMING OIL CLINIC	4-5
OIL	4-5
FUEL	4-5
COOLANT	4-5
GREASE	4-6
CARRYING OUT KOWA (Komatsu Oil Wear Analysis)	4-6
STORING OIL AND FUEL	4-7
FILTERS	4-7
OUTLINE OF ELECTRIC SYSTEM	4-7
WEAR PARTS LIST	4-8
WEAR PARTS LIST	4-8

CONTENTS

USE OF FUEL, COOLANT AND LUBRICANTS ACCORDING TO AMBIENT TEMPERATURE	4-9
PROPER SELECTION OF FUEL, COOLANT AND LUBRICANTS	4-9
STANDARD TIGHTENING TORQUES FOR BOLTS AND NUTS	4-13
TORQUE LIST	4-13
PERIODIC REPLACEMENT OF SAFETY CRITICAL PARTS	4-14
SAFETY CRITICAL PARTS.....	4-15
MAINTENANCE SCHEDULE CHART	4-17
MAINTENANCE SCHEDULE CHART	4-17
INITIAL 250 HOURS SERVICE(OONLY AFTER THE FIRST 250 HOURS)	4-17
WHEN REQUIRED	4-17
CHECK BEFORE STARTING	4-17
EVERY 250 HOURS SERVICE	4-17
EVERY 500 HOURS SERVICE	4-17
EVERY 1000 HOURS SERVICE	4-18
EVERY 2000 HOURS SERVICE	4-18
EVERY 4000 HOURS SERVICE	4-18
EVERY 8000 HOURS SERVICE	4-18
SERVICE PROCEDURE	4-19
INITIAL 250 HOURS SERVICE(OONLY AFTER THE FIRST 250 HOURS).....	4-19
WHEN REQUIRED	4-19
CHECK BEFORE STARTING	4-37
EVERY 250 HOURS SERVICE	4-38
EVERY 500 HOURS SERVICE	4-45
EVERY 1000 HOURS SERVICE	4-49
EVERY 2000 HOURS SERVICE	4-53
EVERY 4000 HOURS SERVICE	4-58
EVERY 8000 HOURS SERVICE	4-61

SPECIFICATIONS

SPECIFICATIONS	5-2
-----------------------------	-----

ATTACHMENTS, OPTIONS

GENERAL PRECAURIONS	6-2
PRECAUTIONS RELATED TO SAFETY	6-2
SELECTION OF TRACK SHOE	6-3
SELECTION OF TRACK SHOES.....	6-3
PROCEDURE FOR SELECTING RIPPER POINT	6-4
PROCEDURE FOR SELECTING RIPPER POINT.....	6-4

CAP WITH LOCK, HANDLING 6-5
 METHOD OF OPENING AND CLOSING CAP WITH LOCK..... 6-5

INDEX

COLOPHON

Komatsu Bulldozer D85 Ex Px 15 Operation Maintenance Manual

Full download: <http://manualplace.com/download/komatsu-bulldozer-d85-ex-px-15-operation-maintenance-manual/>

CONTENTS
