

# Shop Manual

# GALEO

## D51EX-22

## D51PX-22

### CRAWLER TRACTOR

SERIAL NUMBERS **D51EX-22** **B10001** and UP  
**D51PX-22** **B10001**

This material is proprietary to Komatsu America Corp. and is not to be reproduced, used, or disclosed except in accordance with written authorization from Komatsu America Corp.

It is our policy to improve our products whenever it is possible and practical to do so. We reserve the right to make changes or add improvements at any time without incurring any obligation to install such changes on products sold previously.

Due to this continuous program of research and development, periodic revisions may be made to this publication. It is recommended that customers contact their distributor for information on the latest revision.

## CONTENTS

GENERAL .....	01-1
STRUCTURE, FUNCTION AND MAINTENANCE STANDARD .....	10-1
STANDARD VALUE TABLES .....	20-1
TESTING AND ADJUSTING .....	30-1
TROUBLESHOOTING.....	40-1
DISASSEMBLY AND ASSEMBLY.....	50-1
OTHER.....	90-1

# FOREWORD

The affected pages are indicated by using the following marks. It is requested that necessary actions be taken to these pages according to the table below.

Mark	Indication	Action
○	New page to be added	Add
●	Page to be replaced	Replace
( )	Page to be deleted	Discard

Mark	Page	Rev
●	00-1	④
	00-2	①
●	00-2-1	④
●	00-2-2	④
●	00-2-3	④
●	00-2-4	④
●	00-2-5	④
●	00-2-6	④
●	00-2-7	④
●	00-2-8	④
●	00-2-9	④
○	00-2-10	④
	00-3	
	00-4	
	00-5	
	00-6	
	00-7	
	00-8	
	00-9	
	00-10	
	00-11	
	00-12	
	00-13	
	00-14	
	00-15	
	00-16	
	00-17	
	00-18	
	00-19	

Mark	Page	Rev
	00-20	
	00-21	
	00-22	
	00-23	
	00-24	
	00-25	
	00-26	
	00-27	
	00-28	
	01-1	
	01-2	③
	01-3	③
	01-4	
	01-5	
	01-6	③
	01-7	
	01-8	
	01-9	
	01-10	
	01-11	
	01-12	
	10-1	③
	10-2	③
	10-3	
	10-4	
	10-5	
	10-6	

Mark	Page	Rev
	10-7	
	10-8	
	10-9	
	10-10	
	10-11	
	10-12	
	10-13	
	10-14	
	10-15	
	10-16	
	10-17	
	10-18	
	10-19	
	10-20	
	10-21	
	10-22	
	10-23	
	10-24	
	10-25	
	10-26	
	10-27	
	10-28	③
	10-29	③
	10-30	
	10-31	
	10-32	
	10-33	③
	10-34	③
	10-35	③

Mark	Page	Rev
	10-36	③
	10-37	③
	10-38	③
	10-39	③
	10-40	③
	10-41	③
	10-42	③
	10-43	③
	10-44	③
	10-45	③
	10-46	③
	10-47	③
	10-48	③
	10-49	③
	10-50	③
	10-51	③
	10-52	③
	10-53	③
	10-54	③
	10-55	③
	10-56	③
	10-57	③
	10-58	③
	10-59	③
	10-60	③
	10-61	③
	10-62	③
	10-63	③
	10-64	③

# FOREWORD

Mark	Page	Rev	Mark	Page	Rev	Mark	Page	Rev	Mark	Page	Rev
	10-65	③		10-98	③		10-131	③		10-164	
	10-66	③		10-99	③		10-132	③		10-165	
	10-67	③		10-100	③		10-133	③		10-166	
	10-68	③		10-101	③		10-134	③		10-167	
	10-69	③		10-102	③		10-135	③		10-168	
	10-70	③		10-103	③		10-136	③		10-169	
	10-71	③		10-104	③		10-137	③		10-170	
	10-72	③		10-105	③		10-138	③		10-171	
	10-73	③		10-106	③		10-139	③		10-172	
	10-74	③		10-107	③		10-140	③		10-173	
	10-75	③		10-108	③		10-141	③		10-174	
	10-76	③		10-109	③		10-142			10-175	
	10-77	③		10-110	③		10-143			10-176	
	10-78	③		10-111	③		10-144			10-177	
	10-79	③		10-112	③		10-145			10-178	
	10-80	③		10-113	③		10-146			10-179	
	10-81	③		10-114	③		10-147			10-180	
	10-82	③		10-115	③		10-148			10-181	
	10-83	③		10-116	③		10-149			10-182	
	10-84	③		10-117	③		10-150			10-183	
	10-85	③		10-118	③		10-151			10-184	
	10-86	③		10-119	③		10-152			10-185	
	10-87	③		10-120	③		10-153			10-186	
	10-88	③		10-121	③		10-154			10-187	
	10-89	③		10-122	③		10-155			10-188	
	10-90	③		10-123	③		10-156				
	10-91	③		10-124	③		10-157			20-1	
	10-92	③		10-125	③		10-158		●	20-2	④
	10-93	③		10-126	③		10-159			20-3	
	10-94	③		10-127	③		10-160			20-4	
	10-95	③		10-128	③		10-161			20-5	
	10-96	③		10-129	③		10-162			20-6	
	10-97	③		10-130	③		10-163			20-7	

# FOREWORD

Mark	Page	Rev	Mark	Page	Rev	Mark	Page	Rev	Mark	Page	Rev
	20-8			30-30			30-63			30-96	
	20-9			30-31			30-64			30-97	
	20-10			30-32			30-65			30-98	
				30-33			30-66			30-99	
	30-1			30-34			30-67			30-100	
	30-2			30-35			30-68			30-101	
	30-3			30-36			30-69			30-102	
	30-4			30-37			30-70			30-103	
	30-5			30-38			30-71			30-104	
	30-6			30-39			30-72			30-105	
	30-7			30-40			30-73			30-106	
	30-8			30-41			30-74			30-107	
	30-9			30-42			30-75			30-108	
	30-10			30-43			30-76			30-109	
	30-11			30-44			30-77			30-110	
	30-12			30-45			30-78			30-111	
	30-13			30-46			30-79			30-112	
	30-14			30-47			30-80			30-113	
	30-15			30-48			30-81			30-114	
	30-16			30-49			30-82			30-115	
	30-17			30-50			30-83			30-116	
	30-18			30-51			30-84			30-117	
	30-19			30-52			30-85			30-118	
	30-20			30-53			30-86			30-119	
	30-21			30-54			30-87			30-120	
	30-22			30-55			30-88			30-121	
	30-23			30-56			30-89			30-122	
	30-24			30-57			30-90			30-123	
	30-25			30-58			30-91			30-124	
	30-26			30-59			30-92			30-125	
	30-27			30-60			30-93			30-126	
	30-28			30-61			30-94			30-127	
	30-29			30-62			30-95			30-128	

# FOREWORD

Mark	Page	Rev	Mark	Page	Rev	Mark	Page	Rev	Mark	Page	Rev
	30-129			40-121			40-202	①		40-235	①
	30-130			40-122			40-203	①		40-236	①
	30-131			40-123			40-204	①		40-237	①
	30-132			40-124			40-205	①		40-238	①
	30-133			40-125			40-206	①		40-239	①
	30-134			40-126			40-207	①		40-240	①
	30-135			40-127			40-208	①		40-241	①
	30-136			40-128			40-209	①		40-242	①
	30-137			40-129			40-210	①		40-243	①
	30-138			40-130			40-211	①		40-244	①
	30-139			40-131			40-212	①		40-245	①
	30-140			40-132			40-213	①		40-246	①
				40-133			40-214	①		40-247	①
	40-101			40-134			40-215	①		40-248	①
	40-102			40-135			40-216	①		40-249	①
	40-103			40-136			40-217	①		40-250	①
	40-104			40-137			40-218	①		40-251	①
	40-105			40-138			40-219	①		40-252	①
	40-106			40-139			40-220	①		40-253	①
	40-107			40-140			40-221	①		40-254	①
	40-108			40-141			40-222	①		40-255	①
	40-109			40-142			40-223	①		40-256	①
	40-110			40-143			40-224	①		40-257	①
	40-111			40-144			40-225	①		40-258	①
	40-112			40-145			40-226	①		40-259	①
	40-113			40-146			40-227	①		40-260	①
	40-114			40-147			40-228	①		40-261	①
	40-115			40-148			40-229	①		40-262	①
	40-116			40-149			40-230	①		40-263	①
	40-117			40-150			40-231	①		40-264	①
	40-118			40-151			40-232	①		40-265	①
	40-119						40-233	①		40-266	①
	40-120			40-201	①		40-234	①		40-267	①

# FOREWORD

Mark	Page	Rev	Mark	Page	Rev	Mark	Page	Rev	Mark	Page	Rev
	40-268	①		40-301	①		40-334	①		40-367	①
	40-269	①		40-302	①		40-335	①		40-368	①
	40-270	①		40-303	①		40-336	①		40-369	①
	40-271	①		40-304	①		40-337	①		40-370	①
	40-272	①		40-305	①		40-338	①		40-371	①
	40-273	①		40-306	①		40-339	①		40-372	①
●	40-274	④		40-307	①		40-340	①		40-373	①
	40-275	①		40-308	①		40-341	①		40-374	①
	40-276	①		40-309	①		40-342	①		40-375	①
	40-277	①		40-310	①		40-343	①		40-376	①
	40-278	①		40-311	①		40-344	①		40-377	①
	40-279	①		40-312	①		40-345	①		40-378	①
	40-280	①		40-313	①		40-346	①		40-379	①
	40-281	①		40-314	①		40-347	①		40-380	①
	40-282	①		40-315	①		40-348	①		40-381	①
	40-283	①		40-316	①		40-349	①		40-382	①
	40-284	①		40-317	①		40-350	①		40-383	①
	40-285	①		40-318	①		40-351	①		40-384	①
	40-286	①		40-319	①		40-352	①		40-385	①
	40-287	①		40-320	①		40-353	①		40-386	①
	40-288	①		40-321	①		40-354	①		40-387	①
	40-289	①		40-322	①		40-355	①		40-388	①
	40-290	①		40-323	①		40-356	①		40-389	①
	40-291	①		40-324	①		40-357	①		40-390	①
	40-292	①		40-325	①		40-358	①		40-391	①
	40-293	①		40-326	①		40-359	①		40-392	①
	40-294	①		40-327	①		40-360	①		40-393	①
	40-295	①		40-328	①		40-361	①		40-394	①
	40-296	①		40-329	①		40-362	①		40-395	①
	40-297	①		40-330	①		40-363	①		40-396	①
	40-298	①		40-331	①		40-364	①		40-397	①
	40-299	①		40-332	①		40-365	①		40-398	①
	40-300	①		40-333	①		40-366	①		40-399	①

# FOREWORD

Mark	Page	Rev	Mark	Page	Rev	Mark	Page	Rev	Mark	Page	Rev
	40-400	①		40-433	①		40-466	①		40-522	①
	40-401	①		40-434	①		40-467	①		40-523	①
	40-402	①		40-435	①		40-468	①		40-524	①
	40-403	①		40-436	①		40-469	①		40-525	①
	40-404	①		40-437	①		40-470	①		40-526	①
	40-405	①		40-438	①		40-471	①		40-527	①
	40-406	①		40-439	①		40-472	①		40-528	①
	40-407	①		40-440	①		40-473	①		40-529	①
	40-408	①		40-441	①		40-474	①		40-530	①
	40-409	①		40-442	①		40-475	①		40-531	①
	40-410	①		40-443	①		40-476	①		40-532	①
	40-411	①		40-444	①					40-533	①
	40-412	①		40-445	①		40-501	①		40-534	①
	40-413	①		40-446	①		40-502	①		40-535	①
	40-414	①		40-447	①		40-503	①		40-536	①
	40-415	①		40-448	①		40-504	①		40-537	①
	40-416	①		40-449	①		40-505	①		40-538	①
	40-417	①		40-450	①		40-506	①		40-539	①
	40-418	①		40-451	①		40-507	①		40-540	①
	40-419	①		40-452	①		40-508	①		40-541	①
	40-420	①		40-453	①		40-509	①		40-542	①
	40-421	①		40-454	①		40-510	①		40-543	①
	40-422	①		40-455	①		40-511	①		40-544	①
	40-423	①		40-456	①		40-512	①		40-545	①
	40-424	①		40-457	①		40-513	①		40-546	①
	40-425	①		40-458	①		40-514	①		40-547	①
	40-426	①		40-459	①		40-515	①		40-548	①
	40-427	①		40-460	①		40-516	①		40-549	①
	40-428	①		40-461	①		40-517	①		40-550	①
	40-429	①		40-462	①		40-518	①		40-551	①
	40-430	①		40-463	①		40-519	①		40-552	①
	40-431	①		40-464	①		40-520	①		40-553	①
	40-432	①		40-465	①		40-521	①		40-554	①



# FOREWORD

Mark	Page	Rev	Mark	Page	Rev	Mark	Page	Rev	Mark	Page	Rev
	40-555	①		40-613	①		40-721	①	●	50-29	④
	40-556	①		40-614	①		40-722	①	●	50-30	④
	40-557	①		40-615	①		40-723	①	●	50-31	④
	40-558	①		40-616	①		40-724	①	●	50-32	④
	40-559	①		40-617	①				●	50-33	④
	40-560	①		40-618	①	●	50-1	④	●	50-34	④
	40-561	①		40-619	①	●	50-2	④	●	50-35	④
	40-562	①		40-620	①	●	50-3	④	●	50-36	④
	40-563	①		40-621	①		50-4	①	●	50-37	④
	40-564	①		40-622	①		50-5	①	●	50-38	④
	40-565	①		40-623	①		50-6	①	●	50-39	④
	40-566	①		40-624	①		50-7	①	●	50-40	④
	40-567	①				●	50-8	④	●	50-41	④
	40-568	①		40-701	①		50-9	①	●	50-42	④
	40-569	①		40-702	①	●	50-10	④	●	50-43	④
	40-570	①		40-703	①	●	50-11	④	●	50-44	④
	40-571	①		40-704	①	●	50-12	④	●	50-45	④
	40-572	①		40-705	①	●	50-13	④	●	50-46	④
	40-573	①		40-706	①	●	50-14	④	●	50-47	④
	40-574	①		40-707	①	●	50-15	④	●	50-48	④
				40-708	①	●	50-16	④	●	50-49	④
	40-601	①		40-709	①	●	50-17	④	●	50-50	④
	40-602	①		40-710	①	●	50-18	④	●	50-51	④
	40-603	①		40-711	①	●	50-19	④	●	50-52	④
	40-604	①		40-712	①	●	50-20	④	●	50-53	④
	40-605	①		40-713	①	●	50-21	④	●	50-54	④
	40-606	①		40-714	①	●	50-22	④	●	50-55	④
	40-607	①		40-715	①	●	50-23	④	●	50-56	④
	40-608	①		40-716	①	●	50-24	④	●	50-57	④
	40-609	①		40-717	①	●	50-25	④	●	50-58	④
	40-610	①		40-718	①	●	50-26	④	●	50-59	④
	40-611	①		40-719	①	●	50-27	④	●	50-60	④
	40-612	①		40-720	①	●	50-28	④	●	50-61	④

# FOREWORD

Mark	Page	Rev	Mark	Page	Rev	Mark	Page	Rev	Mark	Page	Rev
●	50-62	④	●	50-95	④	●	50-128	④	●	50-161	④
●	50-63	④	●	50-96	④	●	50-129	④	●	50-162	④
●	50-64	④	●	50-97	④	●	50-130	④	●	50-163	④
●	50-65	④	●	50-98	④	●	50-131	④	●	50-164	④
●	50-66	④	●	50-99	④	●	50-132	④	●	50-165	④
●	50-67	④	●	50-100	④	●	50-133	④	●	50-166	④
●	50-68	④	●	50-101	④	●	50-134	④	●	50-167	④
●	50-69	④	●	50-102	④	●	50-135	④	●	50-168	④
●	50-70	④	●	50-103	④	●	50-136	④	●	50-169	④
●	50-71	④	●	50-104	④	●	50-137	④	●	50-170	④
●	50-72	④	●	50-105	④	●	50-138	④	●	50-171	④
●	50-73	④	●	50-106	④	●	50-139	④	●	50-172	④
●	50-74	④	●	50-107	④	●	50-140	④	●	50-173	④
●	50-75	④	●	50-108	④	●	50-141	④	●	50-174	④
●	50-76	④	●	50-109	④	●	50-142	④	●	50-175	④
●	50-77	④	●	50-110	④	●	50-143	④	●	50-176	④
●	50-78	④	●	50-111	④	●	50-144	④	●	50-177	④
●	50-79	④	●	50-112	④	●	50-145	④	●	50-178	④
●	50-80	④	●	50-113	④	●	50-146	④	●	50-179	④
●	50-81	④	●	50-114	④	●	50-147	④	●	50-180	④
●	50-82	④	●	50-115	④	●	50-148	④	●	50-181	④
●	50-83	④	●	50-116	④	●	50-149	④	●	50-182	④
●	50-84	④	●	50-117	④	●	50-150	④	●	50-183	④
●	50-85	④	●	50-118	④	●	50-151	④	●	50-184	④
●	50-86	④	●	50-119	④	●	50-152	④	●	50-185	④
●	50-87	④	●	50-120	④	●	50-153	④	●	50-186	④
●	50-88	④	●	50-121	④	●	50-154	④	●	50-187	④
●	50-89	④	●	50-122	④	●	50-155	④	●	50-188	④
●	50-90	④	●	50-123	④	●	50-156	④	●	50-189	④
●	50-91	④	●	50-124	④	●	50-157	④	●	50-190	④
●	50-92	④	●	50-125	④	●	50-158	④	●	50-191	④
●	50-93	④	●	50-126	④	●	50-159	④	●	50-192	④
●	50-94	④	●	50-127	④	●	50-160	④	●	50-193	④

# FOREWORD

Mark	Page	Rev	Mark	Page	Rev	Mark	Page	Rev	Mark	Page	Rev
●	50-194	④	●	50-227	④	●	50-260	④	●	50-293	④
●	50-195	④	●	50-228	④	●	50-261	④	●	50-294	④
●	50-196	④	●	50-229	④	●	50-262	④	●	50-295	④
●	50-197	④	●	50-230	④	●	50-263	④	●	50-296	④
●	50-198	④	●	50-231	④	●	50-264	④	●	50-297	④
●	50-199	④	●	50-232	④	●	50-265	④	●	50-298	④
●	50-200	④	●	50-233	④	●	50-266	④	○	50-299	④
●	50-201	④	●	50-234	④	●	50-267	④	○	50-300	④
●	50-202	④	●	50-235	④	●	50-268	④	○	50-301	④
●	50-203	④	●	50-236	④	●	50-269	④	○	50-302	④
●	50-204	④	●	50-237	④	●	50-270	④	○	50-303	④
●	50-205	④	●	50-238	④	●	50-271	④	○	50-304	④
●	50-206	④	●	50-239	④	●	50-272	④	○	50-305	④
●	50-207	④	●	50-240	④	●	50-273	④	○	50-306	④
●	50-208	④	●	50-241	④	●	50-274	④	○	50-307	④
●	50-209	④	●	50-242	④	●	50-275	④	○	50-308	④
●	50-210	④	●	50-243	④	●	50-276	④	○	50-309	④
●	50-211	④	●	50-244	④	●	50-277	④	○	50-310	④
●	50-212	④	●	50-245	④	●	50-278	④	○	50-311	④
●	50-213	④	●	50-246	④	●	50-279	④	○	50-312	④
●	50-214	④	●	50-247	④	●	50-280	④	○	50-313	④
●	50-215	④	●	50-248	④	●	50-281	④	○	50-314	④
●	50-216	④	●	50-249	④	●	50-282	④	○	50-315	④
●	50-217	④	●	50-250	④	●	50-283	④	○	50-316	④
●	50-218	④	●	50-251	④	●	50-284	④	○	50-317	④
●	50-219	④	●	50-252	④	●	50-285	④	○	50-318	④
●	50-220	④	●	50-253	④	●	50-286	④	○	50-319	④
●	50-221	④	●	50-254	④	●	50-287	④	○	50-320	④
●	50-222	④	●	50-255	④	●	50-288	④	○	50-321	④
●	50-223	④	●	50-256	④	●	50-289	④	○	50-322	④
●	50-224	④	●	50-257	④	●	50-290	④	○	50-323	④
●	50-225	④	●	50-258	④	●	50-291	④	○	50-324	④
●	50-226	④	●	50-259	④	●	50-292	④	○	50-325	④

# FOREWORD

Mark	Page	Rev
○	50-326	④
○	50-327	④
○	50-328	④
○	50-329	④
○	50-330	④
○	50-331	④
○	50-332	④
○	50-333	④
○	50-334	④
○	50-335	④
○	50-336	④
○	50-337	④
○	50-338	④
○	50-339	④
○	50-340	④
○	50-341	④
○	50-342	④
○	50-343	④
○	50-344	④
○	50-345	④
○	50-346	④
○	50-347	④
○	50-348	④
○	50-349	④
○	50-350	④
○	50-351	④
○	50-352	④
○	50-353	④
○	50-354	④
	90-1	
	90-3	
	90-4	
	90-5	



Mark	Page	Rev
	90-7	
	90-9	
	90-11	
	90-13	
	90-15	
●	90-17	④
	90-19	
	90-21	
	90-23	
	90-25	③
	90-27	③
	90-29	
	90-31	
	90-33	
	90-35	
	90-37	③

# SAFETY

## SAFETY NOTICE

### IMPORTANT SAFETY NOTICE

Proper service and repair is extremely important for the safe operation of your machine. The service and repair techniques recommended and described in this manual are both effective and safe methods of operation. Some of these operations require the use of tools specially designed for the purpose.

To prevent injury to workers, the symbols  and  are used to mark safety precautions in this manual. The cautions accompanying these symbols should always be followed carefully. If any dangerous situation arises or may possibly arise, first consider safety, and take the necessary actions to deal with the situation.

### GENERAL PRECAUTIONS

Mistakes in operation are extremely dangerous. Read the OPERATION & MAINTENANCE MANUAL carefully BEFORE operating the machine.

1. Before carrying out any greasing or repairs, read all the precautions given on the decals which are fixed to the machine.
2. When carrying out any operation, always wear safety shoes and helmet. Do not wear loose work clothes, or clothes with buttons missing.
  - Always wear safety glasses when hitting parts with a hammer.
  - Always wear safety glasses when grinding parts with a grinder, etc.
3. If welding repairs are needed, always have a trained, experienced welder carry out the work. When carrying out welding work, always wear welding gloves, apron, glasses, cap and other clothes suited for welding work.
4. When carrying out any operation with two or more workers, always agree on the operating procedure before starting. Always inform your fellow workers before starting any step of the operation. Before starting work, hang UNDER REPAIR signs on the controls in the operator's compartment.
5. Keep all tools in good condition and learn the correct way to use them.
6. Decide a place in the repair workshop to keep tools and removed parts. Always keep the tools and parts in their correct places. Always keep the work area clean and make sure that there is no dirt or oil on the floor. Smoke only in the areas provided for smoking. Never smoke while working.

### PREPARATIONS FOR WORK

1. Before adding oil or making repairs, park the machine on hard, level ground, and block the wheels or tracks to prevent the machine from moving.
2. Before starting work, lower blade, ripper, bucket or any other work equipment to the ground. If this is not possible, insert the safety pin or use blocks to prevent the work equipment from falling. In addition, be sure to lock all the control levers and hang warning signs on them.
3. When disassembling or assembling, support the machine with blocks, jacks or stands before starting work.
4. Remove all mud and oil from the steps or other places used to get on and off the machine. Always use the handrails, ladders or steps when getting on or off the machine. Never jump on or off the machine. If it is impossible to use the handrails, ladders or steps, use a stand to provide safe footing.

### PRECAUTIONS DURING WORK

1. When removing the oil filler cap, drain plug or hydraulic pressure measuring plugs, loosen them slowly to prevent the oil from spurting out. Before disconnecting or removing components of the oil, water or air circuits, first remove the pressure completely from the circuit.
2. The water and oil in the circuits are hot when the engine is stopped, so be careful not to get burned. Wait for the oil and water to cool before carrying out any work on the oil or water circuits.
3. Before starting work, remove the leads from the battery. ALWAYS remove the lead from the negative (-) terminal first.

4. When raising heavy components, use a hoist or crane. Check that the wire rope, chains and hooks are free from damage. Always use lifting equipment which has ample capacity. Install the lifting equipment at the correct places. Use a hoist or crane and operate slowly to prevent the component from hitting any other part. Do not work with any part still raised by the hoist or crane.
5. When removing covers which are under internal pressure or under pressure from a spring, always leave two bolts in position on opposite sides. Slowly release the pressure, then slowly loosen the bolts to remove.
6. When removing components, be careful not to break or damage the wiring. Damaged wiring may cause electrical fires.
7. When removing piping, stop the fuel or oil from spilling out. If any fuel or oil drips on to the floor, wipe it up immediately. Fuel or oil on the floor can cause you to slip, or can even start fires.
8. Never use flammable liquids to clean parts, use only non-flammable approved cleaning solutions to clean parts.
9. Be sure to assemble all parts again in their original places. Replace any damaged part with new parts.
  - When installing hoses and wires, be sure that they will not be damaged by contact with other parts when the machine is being operated.
10. When installing high pressure hoses, make sure that they are not twisted. Damaged tubes are dangerous, so be extremely careful when installing tubes for high pressure circuits. Also check that connecting parts are correctly installed.
11. When assembling or installing parts, always use the specified tightening torques. When installing protective parts such as guards, or parts which vibrate violently or rotate at high speed, be particularly careful to check that they are installed correctly.
12. When aligning two holes, never insert your fingers or hand. Be careful not to get your fingers caught in a hole.
13. When measuring hydraulic pressure, check that the measuring tool is correctly assembled before taking any measurements.
14. Take care when removing or installing the tracks of track-type machines. When removing the track, the track separates suddenly, so never let anyone stand at either end of the track.

## GENERAL

This shop manual has been prepared as an aid to improve the quality of repairs by giving the serviceman an accurate understanding of the product and by showing him the correct way to perform repairs and make judgements. Make sure you understand the contents of this manual and use it to full effect at every opportunity.

This shop manual mainly contains the necessary technical information for operations performed in a service workshop. For ease of understanding, the manual is divided into the following sections. These sections are further divided into each main group of components.

### GENERAL

This section lists the general machine dimensions, performance specifications, component weights, and fuel, coolant and lubricant specification charts.

### STRUCTURE, FUNCTION AND MAINTENANCE STANDARD

This section explains the structure and function of each component. It serves not only to give an understanding of the structure, but also serves as reference material for troubleshooting. In addition, this section gives the judgement standards when inspecting disassembled parts.

### TESTING AND ADJUSTING

This section explains checks to be made before and after performing repairs, as well as adjustments to be made at completion of the checks and repairs.

### TROUBLESHOOTING

Troubleshooting charts correlating "Problems" to "Causes" are also included in this section.

### DISASSEMBLY AND ASSEMBLY

This section explains the order to be followed when removing, installing, disassembling or assembling each component, as well as precautions to be taken for these operations.

### OTHER

This section has the foldout drawings for the machine.

#### NOTICE

The specifications contained in this shop manual are subject to change at any time and without any advance notice. Contact your distributor for the latest information.

## HOW TO READ THE SHOP MANUAL

### VOLUMES

Shop manuals are issued as a guide to carrying out repairs. They are divided as follows:

**Chassis volume:** Issued for every machine model

**Engine volume:** Issued for each engine series

**Electrical volume:** Each issued as one to cover all models

**Attachment volume:** Each issued as one to cover all models

These various volumes are designed to avoid duplication of information. Therefore to deal with all repairs for any model, it is necessary that chassis, engine, electrical and attachment be available.

### DISTRIBUTION AND UPDATING

Any additions, amendments or other changes will be sent to your distributors. Get the most up-to-date information before you start any work.

### FILING METHOD

- See the page number on the bottom of the page. File the pages in correct order.
- Following examples show how to read the page number:  
Example:

10 - 3

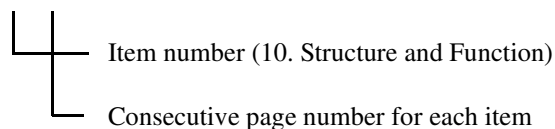

- Additional pages: Additional pages are indicated by a hyphen (-) and numbered after the page number. File as in the example.

Example:

10-4

10-4-1

10-4-2

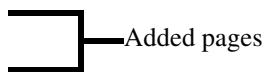

10-5

### REVISED EDITION MARK

When a manual is revised, an edition mark (①②③...) is recorded on the bottom outside corner of the pages.

### REVISIONS

Revised pages are shown at the LIST OF REVISED PAGES between the title page and SAFETY page.

### SYMBOLS

So that the shop manual can be of ample practical use, important places for safety and quality are marked with the following symbols.

Symbol	Item	Remarks
	Safety	Special safety precautions are necessary when performing the work.
★	Caution	Special technical precautions or other precautions for preserving standards are necessary when performing the work.
	Weight	Weight of parts or systems. Caution necessary when selecting hoisting wire or when working posture is important, etc.
	Tightening torque	Places that require special attention for tightening torque during assembly.
	Coat	Places to be coated with adhesives and lubricants etc.
	Fill	Places where oil, water or fuel must be added, and the capacity.
	Drain	Places where oil or water must be drained, and quantity to be drained.



# HOISTING INSTRUCTIONS

## HOISTING



**WARNING!** Heavy parts (25 kg or more) must be lifted with a hoist etc. In the DISASSEMBLY AND ASSEMBLY section, every part weighing 25 kg or more is indicated clearly with the symbol.



- If a part cannot be smoothly removed from the machine by hoisting, the following checks should be made:
  1. Check for removal of all bolts fastening the part to the relative parts.
  2. Check for existence of another part causing interface with the part to be removed.

## WIRE ROPES

1. Use adequate ropes depending on the weight of parts to be hoisted, referring to the table below:

Wire ropes  
(Standard “Z” or “S” twist ropes without galvanizing)

Rope diameter	Allowable load	
	kN	tons
mm		
10	9.8	1.0
11.2	13.7	1.4
12.5	15.7	1.6
14	21.6	2.2
16	27.5	2.8
18	35.3	3.6
20	43.1	4.4
22.4	54.9	5.6
30	98.1	10.0
40	176.5	18.0
50	274.6	28.0
60	392.2	40.0

- ★ The allowable load value is estimated to be 1/6 or 1/7 of the breaking strength of the rope used. Sling wire ropes from the middle portion of the hook.
2. Slings near the edge of the hook may cause the rope to slip off the hook during hoisting, and a serious accident

can result. Hooks have maximum strength at the middle portion.

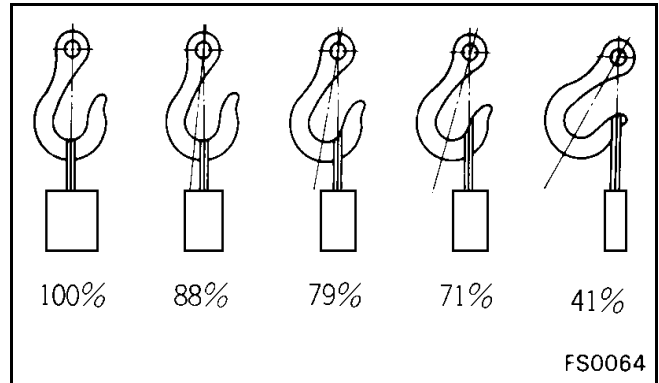

3. Do not sling a heavy load with one rope alone, but sling with two or more ropes symmetrically wound on to the load.



**WARNING!** Slings with one rope may cause turning of the load during hoisting, untwisting of the rope, or slipping of the rope from its original winding position on the load, which can result in a dangerous accident

4. Do not sling a heavy load with ropes forming a wide hanging angle from the hook. When hoisting a load with two or more ropes, the force subjected to each rope will increase with the hanging angles. The table below shows the variation of allowable load (kg) when hoisting is made with two ropes, each of which is allowed to sling up to 1000 kg vertically, at various hanging angles. When two ropes sling a load vertically, up to 2000 kg of total weight can be suspended. This weight becomes 1000 kg when two ropes make a 120° hanging angle. On the other hand, two ropes are subject to an excessive force as large as 4000 kg if they sling a 2000 kg load at a lifting angle of 150°.

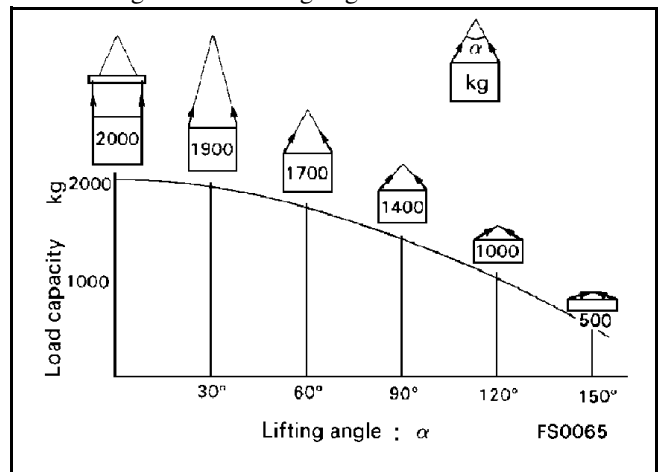

# PUSH PULL COUPLER

**WARNING!** Before carrying out the following work, release the residual pressure from the hydraulic tank. For details, see TESTING AND ADJUSTING, Releasing residual pressure from hydraulic tank.

**WARNING!** Even if the residual pressure is released from the hydraulic tank, some hydraulic oil flows out when the hose is disconnected. Accordingly, prepare an oil receiving container.

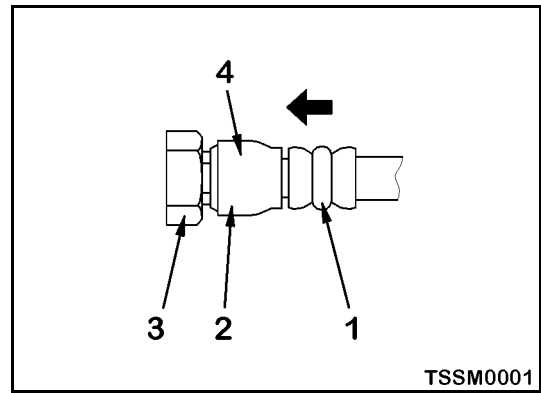

## TYPE 1

### DISCONNECTION

1. Release the residual pressure from the hydraulic tank. For details, see TESTING AND ADJUSTING, Releasing residual pressure from hydraulic tank.
2. Hold the adapter (1) and push the hose joint (2) into the mating adapter (3). The adapter can be pushed in about 3.5 mm. Do not hold the rubber cap portion (4).
3. After the hose joint (2) is pushed into the adapter (3), press the rubber cap portion (4) against the adapter until it clicks.
4. Hold the hose adapter (1) or hose (5) and pull it out. Since some hydraulic oil flows out, prepare an oil receiving container.

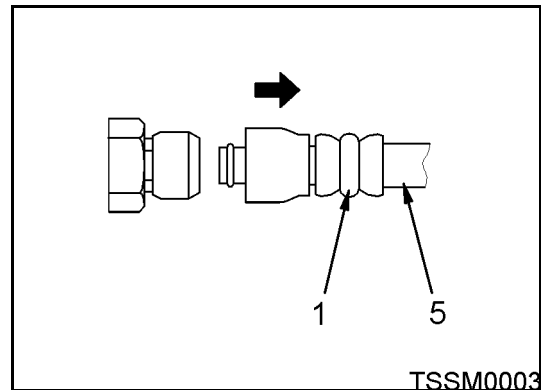
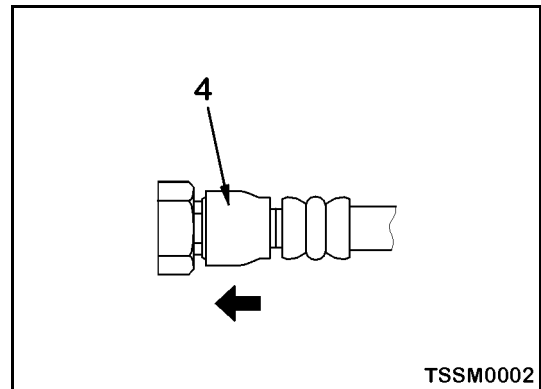

### CONNECTION

1. Hold the hose adapter (1) or hose (5) and insert it in the mating adapter (3), aligning them with each other. Do not hold the rubber cap portion (4).
2. After inserting the hose in the mating adapter, pull it back to check its connecting condition. When the hose is pulled back, the rubber cap portion moves toward the hose about 3.5 mm. This does not indicate an abnormality.

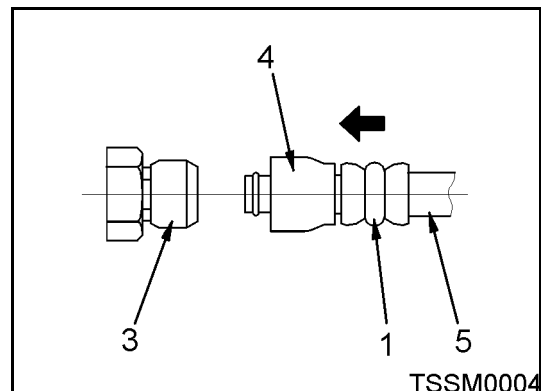

## TYPE 2

## DISCONNECTION

1. Hold the mouthpiece of the tightening portion and push body (2) in straight until sliding prevention ring (1) contacts contact surface **a** of the hexagonal portion at the male end.
2. Hold in the condition in Step 1, and turn the lever (4) to the right - clockwise.
3. Hold in the condition in Steps 1 and 2, and pull out the whole body (2) to disconnect it.

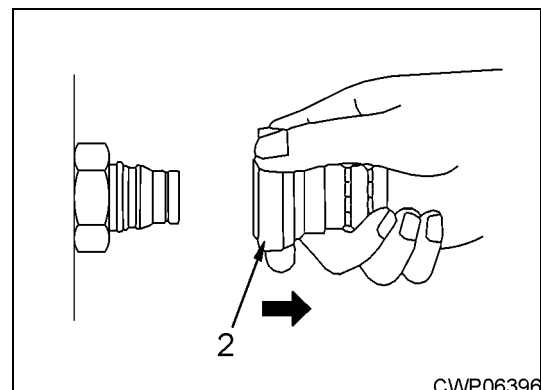
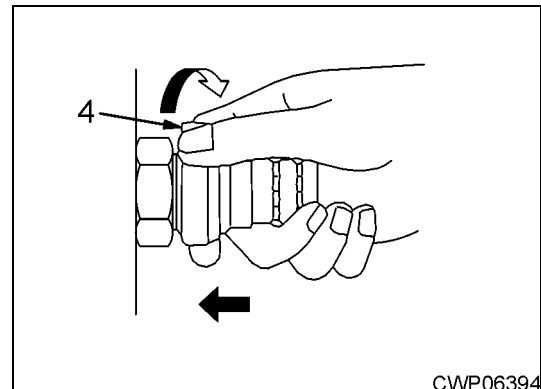
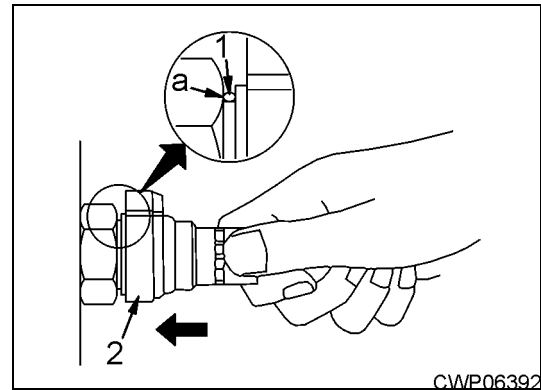

## CONNECTION

1. Hold the connector of the tightening portion and push body (2) in straight until sliding prevention ring (1) contacts surface **a** of the hexagonal portion at the male end to connect it.

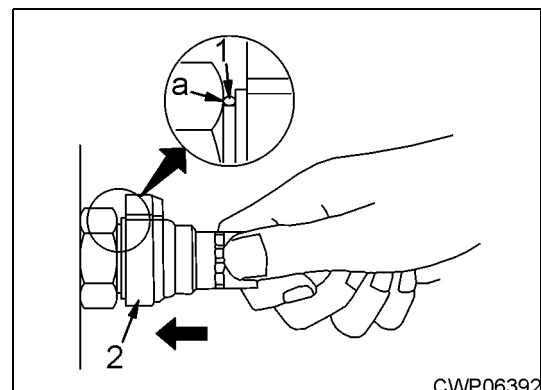

## TYPE 3

### DISCONNECTION

1. Hold the connector of the tightening portion and push the body (2) in straight until sliding prevention ring (1) contacts surface **a** of the hexagonal portion at the male end.
2. Hold in the condition in Step 1, and push until the cover (3) contacts surface **a** of the hexagonal portion at the male end.
3. Hold in the condition in Steps 1 and 2, and pull out the whole body (2) to disconnect it.

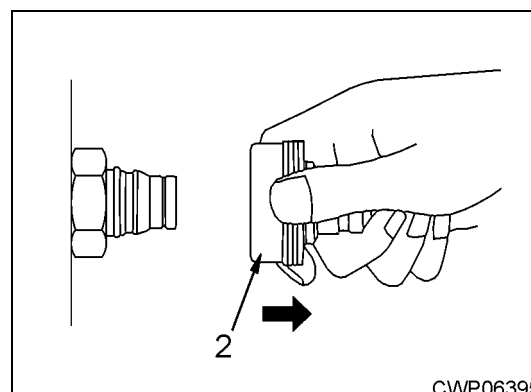
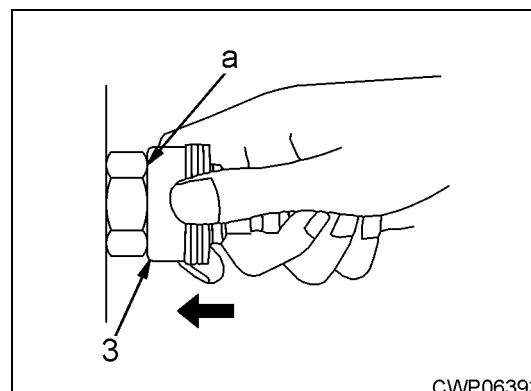
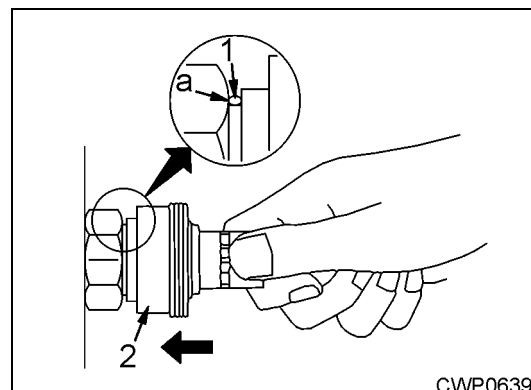

### CONNECTION

1. Hold the connector of the tightening portion and push the body (2) in straight until the slide prevention ring (1) contacts surface **a** of the hexagonal portion at the male end to connect it.

