

HYDRAULIC EXCAVATOR

SHOP MANUAL

model

SK 220 v SK 220lc v

This is the shop manual for KOBELCO hydraulic excavator. Contained is the necessary technical data concerning the maintenance and repair of this model. The manual is divided into the following four major sections; GENERAL, SYSTEMS, COMPONENTS and PROCEDURE.

*GENERAL

- LQ01. SPECIFICATION
— OPERATION AND CONTROLS
(Refer to Operators Manual)
- LQ03. LOCATION AND
WEIGHT OF COMPONENTS

- LQ04. MAINTENANCE STANDARD AND
TEST PROCEDURE
— PREVENTIVE MAINTENANCE
(Refer to Operators Manual)
- LQ07. WORKING STANDARD
- LQ08. STANDARD MAN-HOUR TABLE

*SYSTEMS

- LQ12. HYDRAULIC SYSTEM
- LQ15. SWING FRAME
- LQ18. TRAVEL SYSTEM
- LQ21. ATTACHMENTS

- LQ22. CONTROL SYSTEM
- LQ25. ELECTRICAL SYSTEM
- LQ26. AIR-CONDITIONER SYSTEM
- LQ29. TROUBLE SHOOTING

*COMPONENTS

- 12. HYDRAULIC PUMP
- 13. CONTROL VALVE
- 14. OTHER VALVES
- 15. HYDRAULIC MOTOR

- 16. SWIVEL JOINT
- 17. HYDRAULIC CYLINDER
- 21. REDUCTION UNIT
- 50. ENGINE

*PROCEDURE

When checking or repairing the machine we suggest that you refer to this manual carefully. We hope that reference to this manual will help to maintain a high level of working efficiency and reliability. For further details on maintenance and checks refer to the "OPERATORS MANUAL" which has been supplied with the machine.

Although all data was correct at the time of printing, due to continual design changes and improvements, some contents may not conform to the actual machine. Take special care to order parts only after confirming the validity of the part number in the "PARTS MANUAL".

If you notice any explanatory discrepancies, after consulting one of our representatives, please update your manual according to the latest data. However, in the event of any specification changes, we will issue revised edition.

INDEX

KOBELCO

Book code No. S5LQ0007E①

WARNING

SAFETY

WARNING

The proper and safe lubrication and maintenance for this machine, recommended by KOBELCO are outlined in the OPERATION & MAINTENANCE GUIDE for this machine.

Improper performance of lubrication or maintenance procedures is dangerous and could result in injury or death. Read and understand the OPERATION & MAINTENANCE GUIDE before performing any lubrication or maintenance.

The serviceman or mechanic may be unfamiliar with many of the systems on this machine. This makes it important to use caution when performing service work. A knowledge of the system and or components is important before the removal or disassembly of any component.

Because of the size of some of the machine components, the serviceman or mechanic should check the weights noted in this Manual. Use proper lifting procedures when removing any components.

Following is a list of basic precautions that should always be observed.

1. Read and understand all Warning plates and decals on the machine before operating, lubricating or repairing this product.
2. Always wear protective glasses and protective shoes when working around machines. In particular, wear protective glasses when pounding on any part of the machine or its attachments with a hammer or sledge. Use welders gloves, hood/goggles, apron and other protective clothing appropriate to the welding job being performed. Do not wear loose-fitting or torn clothing. Remove all rings from fingers when working on machinery.
3. Disconnect battery and discharge any capacitors before starting to work on machine. Hang "Do Not Operate" tag in the Operator's Compartment.
4. If possible, make all repairs with the machine parked on a level, hard surface. Block machine so it does not roll while working on or under machine.
5. Do not work on any machine that is supported only by lift jacks or a hoist. Always use blocks or jack stands to support the machine before performing any disassembly.

WARNING

Do not operate this machine unless you have read and understand the instructions in the OPERATOR'S MANUAL. Improper machine operation is dangerous and could result in injury or death.

6. Relieve all pressure in air, oil or water systems before any lines, fittings or related items are disconnected or removed. Always make sure all raised components are blocked correctly and be alert for possible pressure when disconnecting any device from a system that utilizes pressure.
7. Lower the bucket, blade, ripper or other implements to the ground before performing any work on the machine. If this cannot be done, make sure the bucket, blade, ripper or other implement is blocked correctly to prevent it from dropping unexpectedly.
8. Use steps and grab handles when mounting or dismounting a machine. Clean any mud or debris from steps, walkways or work platforms before using. Always face machine when using steps, ladders and walkways. When it is not possible to use the designed access system, provide ladders, scaffolds, or work platforms to perform safe repair operations.
9. To avoid back injury, use a hoist when lifting components which weigh 23 kg (50 lbs) or more. Make sure all chains, hooks, slings, etc., are in good condition and are in the correct capacity. Be sure hooks are positioned correctly. Lifting eyes are not to be side loaded during a lifting operation.
10. To avoid burns, be alert for hot parts on machines which have just been stopped and hot fluids in lines, tubes and compartments.
11. Be careful when removing cover plates. Gradually back off the last two bolts or nuts located at opposite ends of the cover or device and pry cover loose to relieve any spring or other pressure, before removing the last two bolts or nuts completely.
12. Be careful when removing filler caps, breathers and plugs on the machine. Hold a rag over the cap or plug to prevent being sprayed or splashed by liquids under pressure. The danger is even greater if the machine has just been stopped because fluids can be hot.

A WARNING

13. Always use tools that are in good condition and be sure you understand how to use them before performing any service work.
 14. Reinstall all fasteners with same part number. Do not use a lesser quality fastener if replacements are necessary.
 15. Repairs which require welding should be performed only with the benefit of the appropriate reference information and by personnel adequately trained and knowledgeable in welding procedures. Determine type of metal being welded and select correct welding procedure and electrodes, rods or wire to provide a weld metal strength equivalent at least to that of parent metal. Always disconnect battery during welding operations to protect sensitive electric equipment.
 16. Do not damage wiring during removal operations. Reinstall the wiring so it is not damaged nor will it be damaged in operation by contacting sharp corners, or by rubbing against some object or hot surface. Do not connect wiring to a line containing fluid.
 17. Be sure all protective devices including guards and shields are properly installed and functioning correctly before starting a repair. If a guard or shield must be removed to perform the repair work, use extra caution.
 18. Loose or damaged fuel, lubricant and hydraulic lines, tubes and hoses can cause fires. Do not bend or strike high pressure lines or install ones which have been bent or damaged. Inspect lines, tubes and hoses carefully. Do not check for leaks with your hands. Pin hole (very small) leaks can result in a high velocity oil stream that will be invisible close to the hose. This oil can penetrate the skin and cause personal injury. Use cardboard or paper to locate pin hole leaks.
 19. Tighten connections to the correct torque. Make sure that all heat shields, clamps and guards are installed correctly to avoid excessive heat, vibration or rubbing against other parts during operation. Shields that protect against oil spray onto hot exhaust components in event of a line, tube or seal failure must be installed correctly.
 20. Do not operate a machine if any rotating part is damaged or contacts any other part during operation. Any high speed rotating component that has been damaged or altered should be checked for balance before reusing.
 21. On track-type machines, be careful when servicing or separating tracks. Chips can fly when removing or installing a track pin. Wear safety glasses and long sleeve shirts. Track can unroll very quickly when separated. Keep away from front and rear of machine. The machine can move unexpectedly when both tracks are disengaged from the sprockets. Block the machine to prevent it from moving.
 22. Caution should be used to avoid breathing dust that may be generated when handling components containing asbestos fibers. If this dust is inhaled, it can be hazardous to your health. Components in KOBELCO products that may contain asbestos fibers are brake pads, brake band and lining assemblies, clutch plates and some gaskets. The asbestos used in these components is usually bound in a resin or sealed in some way. Normal handling is not hazardous as long as airborne dust which contains asbestos is not generated.
- If dust which may contain asbestos is present, there are several common sense guidelines that should be followed.
- a. Never use compressed air for cleaning.
 - b. Avoid brushing or grinding of asbestos containing materials.
 - c. For clean up, use wet methods or a vacuum equipped with a high efficiency particulate air (HEPA) filter.
 - d. Use exhaust ventilation on permanent machining jobs.
 - e. Wear an approved respirator if there is no other way to control the dust.
 - f. Comply with applicable rules and regulations for the work place.
 - g. Follow environmental rules and regulations for disposal of asbestos.
 - h. Avoid areas where asbestos particles may be in the air.



SHOP MANUAL

model

SK 220 v SK 220LC v

TABLE OF CONTENTS

1. SPECIFICATION
2. OPERATION AND CONTROLS (Refer to Operators Manual)
3. LOCATION AND WEIGHT OF COMPONENTS
4. MAINTENANCE STANDARDS AND TEST PROCEDURES
5.
6. PREVENTIVE MAINTENANCE (Refer to Operators Manual)
7. WORKING STANDARDS
8. STANDARD MAN-HOUR TABLE

LQ01

LQ03

LQ04

LQ07

LQ08

○How to Index each Shop Manual Section

The GENERAL of this shop manual consists of 8 headings as shown above. Each section can be easily referred to by indexes appended to the margin of the page as indicated on the right. Please use the indexes for speedy reference.

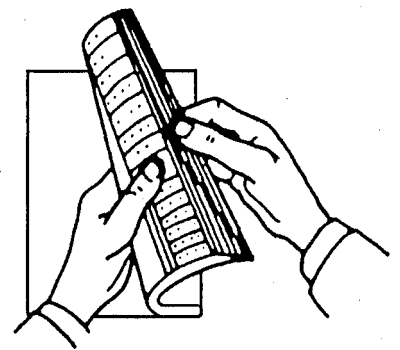

KOBELCO

GENERAL

Book code No. S5LQ0106E

KOBELCO

SHOP MANUAL

SK 220 v

SK 220LC v

LQ01

SPECIFICATION

TABLE OF CONTENTS

1. NAME OF COMPONENTS	1
2. GENERAL DIMENSIONS	2
3. SPECIFICATIONS AND PERFORMANCE	3
4. TYPE OF SHOES	4
5. TYPE AND COMBINATION OF ATTACHMENTS ...	5
6. WORKING RANGES OF ATTACHMENTS	7
7. LIFTING-UP ABILITY DIAGRAM	9
8. ENGINE SPECIFICATIONS	12

Applicable Machines

LQ03301~

LL02301~

Revision	Date of Issue	Remarks
First edition	April, 1994	S5LQ0106E K

1. NAME OF COMPONENTS

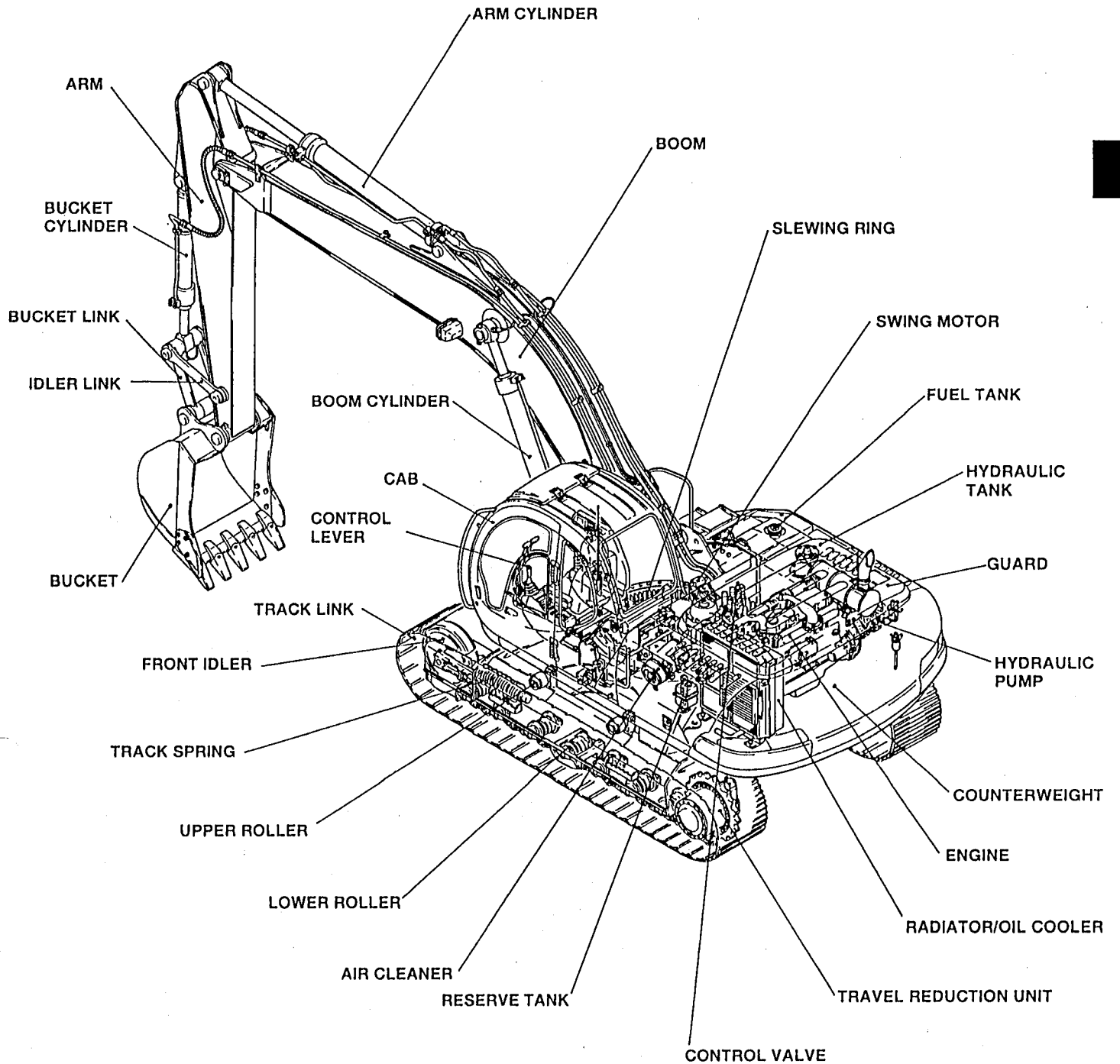

YN-2-1

2. GENERAL DIMENSIONS

- SK220 v AND SK220Lc v with 6.02 m (19 ft-9 in) boom and 2.98 m (9 ft-9 in) standard arm

Unit: mm (ft-in)

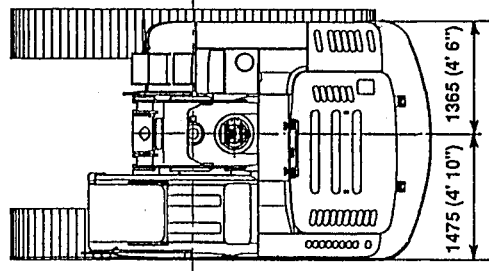

Note: Numerical values marked * do not include the height of the shoe lug. Numerical values enclosed in parentheses [] indicate LC specifications.

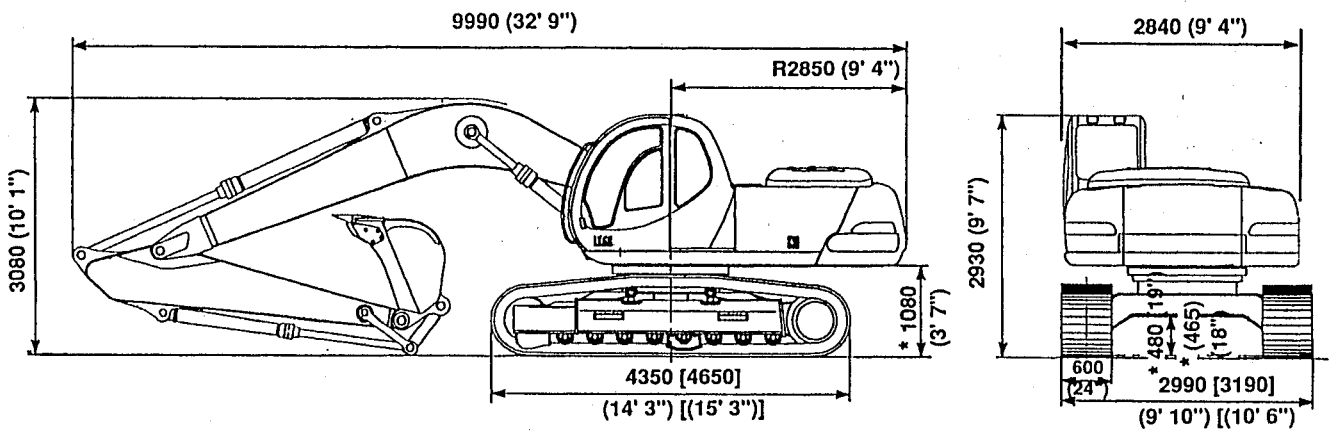

YN-6-4

- SK220 v AND SK220Lc v with 6.02 m (19 ft-9 in) boom and 2.5 m (8 ft-2 in) short arm

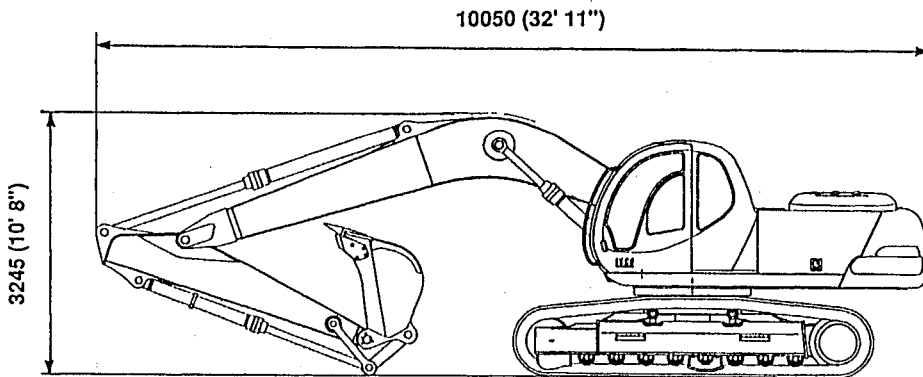

YN-6-5

- SK220 v AND SK220Lc v with 6.02 m (19 ft-9 in) boom and 3.66 m (12 ft) long arm

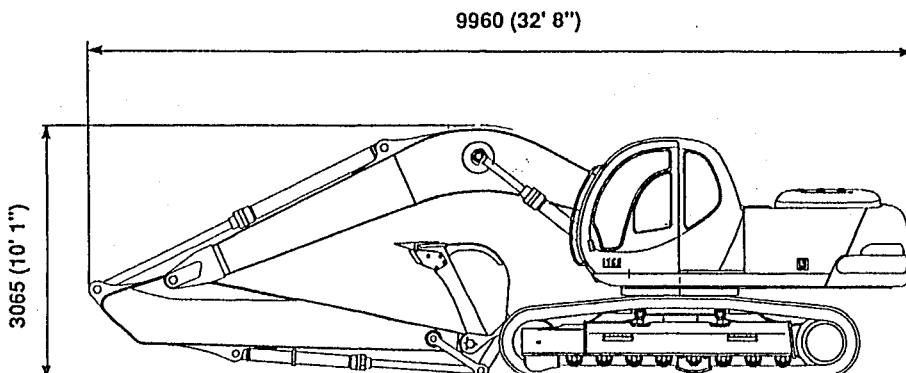

YN-6-6

3. SPECIFICATIONS AND PERFORMANCE

● SPEED AND CLIMBING CAPABILITY

Item \ Model	SK220 v, SK220Lc v
Swing Speed (high/low) rpm	11/4
Travel Speed (high/low) km/h	7/1 km/h (4.3/0.6 mph)
Gradeability	70% (35°)

● ENGINE

Item \ Model	SK220 v, SK220Lc v
Engine model	Mitsubishi 6D15-T
Type	Water-cooled 4-cycle direct injection type engine with an exhaust turbosupercharger
Number of Cylinders — Inner Diameter x Stroke	6—113 mm x 115 mm (4.45 in. x 4.53 in.)
Total Displacement	6,919 cc (422 cuin)
Rated Output/Rotation Speed	165 PS / 2100 rpm
Maximum Torque/Rotation Speed	60 kgf·m / 1600 rpm

● HYDRAULIC COMPONENTS

Item \ Model	SK220 v, SK220Lc v
Hydraulic Pump	Double-pump variable displacement axial piston + gear pump
Hydraulic Motor (swing)	Axial piston motor
Hydraulic Motor (Travel)	Axial piston motor
Control Valve	6-section multiple control valve
Cylinder (boom, arm, and bucket)	Double action cylinder
Oil Cooler	Air-cooled type

● WEIGHT

Unit: kg (lbs)

Item \ Model	SK220 v	SK220Lc v
Fully equipped Weight	23000 (50700)	23600 (52000)
Upper Frame machinery	9500 (20900)	←
Lower Frame machinery with 600mm (24 in) grouser shoe	8870 (19600)	9470 (20900)
Attachment 6.02 m (19 ft-9 in) boom + 2.98 m (9 ft-9 in) arm + 0.9 m ³ (1.18 cuyd) bucket	4630 (10200)	←

4. TYPE OF SHOES

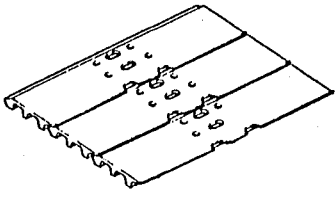
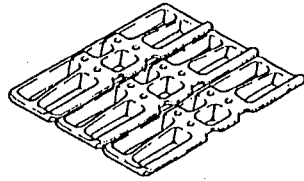
Shape	Model	Shoe Width mm (in.)	Total Width of Crawler mm (ft-in)	Ground Pressure kg/cm ² (psi)
Grouser Shoe  YN-6-7	SK220 v 45 links	600 (24)	2990 (9' 10")	0.50 (7.11)
		700 (28)	3090 (10' 2")	0.44 (6.26)
		800 (32)	3190 (10' 6")	0.39 (5.55)
	SK220Lc v 48 links	600 (24)	3190 (10' 6")	0.48 (6.83)
		700 (28)	3290 (10' 10")	0.42 (5.97)
		800 (32)	3390 (11' 1")	0.37 (5.26)
Flat Shoe  YN-6-8	SK220 v 45 links	600 (24)	2900 (9' 6")	0.51 (7.25)
	SK220Lc-v 48 links	600 (24)	3190 (10' 6")	0.52 (7.39)

Note: Use grouser shoes 600 mm (24in) on rough ground (areas covered with rocks and gravel). If you drive or excavate with other shoes, this may cause shoe bending, shoe bolt looseness, and track assembly (link, roller, etc.) damage.

5. TYPES AND COMBINATION OF ATTACHMENTS

■ TYPES OF BUCKETS

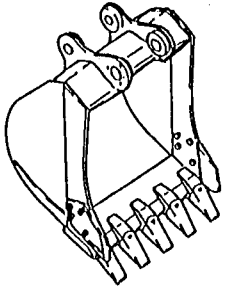
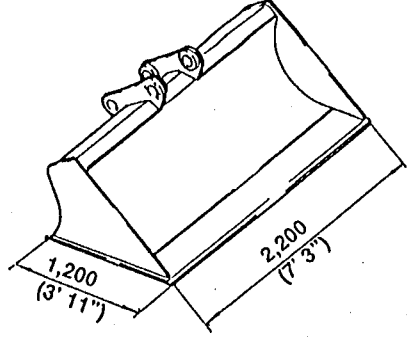
Hoe Bucket	Heaped Capacity m ³ (cuyd)	Outside Width of Bucket mm (ft-in)		Number of Teeth	Equipped with Side Cutters	Can be Turned over	Weight kg (lbs)
		with side cutters	without side cutters				
 YN-6-15	0.7 (0.92)	1060 (3' 6")	960 (3' 2")	4	Yes	Yes	720 (1590)
	0.9 (1.18) (S.T.D.)	1280 (4' 2")	1180 (3' 10")	4	Yes	Yes	790 (1740)
	*0.9 (1.18)	1210 (4')	1170 (3' 10")	5	Yes	Yes	890 (1960)
	1.0 (1.31)	1390 (4' 7")	1290 (4' 3")	5	Yes	Yes	880 (1940)
	1.2 (1.57)	—	1510 (4' 11")	6	No	Yes	950 (2090)
	The numerical value marked * is for heavy excavation.	—	—	—	—	—	—
Slope Finishing Bucket		Weight: 1050 kg (2310 lbs) Can not be turned over					
 YN-6-16							

■ COMBINATIONS OF ATTACHMENTS

Type	Bucket			Applicable Arm		
	JIS heaped capacity m ³ (cuyd)	SAE heaped capacity m ³ (cuyd)	JIS, SAE struck capacity m ³ (cuyd)	2.5 m (8 ft-2in) Arm (short) (Short)	2.98 m (9 ft-9in) Arm (STD) (STD)	3.66 m (12 ft) Arm (long) (long)
Hoe Bucket	0.7 (0.92)	0.81 (1.06)	0.59 (0.81)	○	○	◎
	0.9 (1.18) (STD)	1.04 (1.37)	0.76 (0.98)	○	◎	△
	0.9 (1.18)	1.04 (1.37)	0.76 (0.98)	○	○	×
	1.0 (1.31)	1.16 (1.52)	0.84 (1.09)	◎	△	×
	1.2 (1.57)	1.4 (1.83)	1.0 (1.31)	△	×	×
Slope Finishing Bucket	Width × Depth 2.2m × 1.2m (7 ft-3 in × 3 ft-11 in)	—	—	△	△	×
Ripper	—	—	—	○	○	×
Breaker	—	—	—	○	○	×

Legend

- ◎ Standard combination
- General operation: Excavation or loading of sand, gravel, and clay
- △ Light operation: Mainly loading of loose gravel (e.g., cultivation or loading of sand or gravel)
- × Prohibited combination: KOBELCO's warranty does not cover any damages resulting from these combinations. Do not use these combinations.

Install only genuine attachment recommended by KOBELCO on the machine. KOBELCO is not liable for any damages to the machine or attachment arising from the installment of attachment other than the specified attachments.

⚠ CAUTION

- If any other bucket except for the backhoe bucket, is turned over and used for excavation, damage to the arm and bucket may occur.
- Do not operate the power boost switch when a long arm is installed.

6. WORKING RANGES OF ATTACHMENTS

● BACKHOE ATTACHMENT

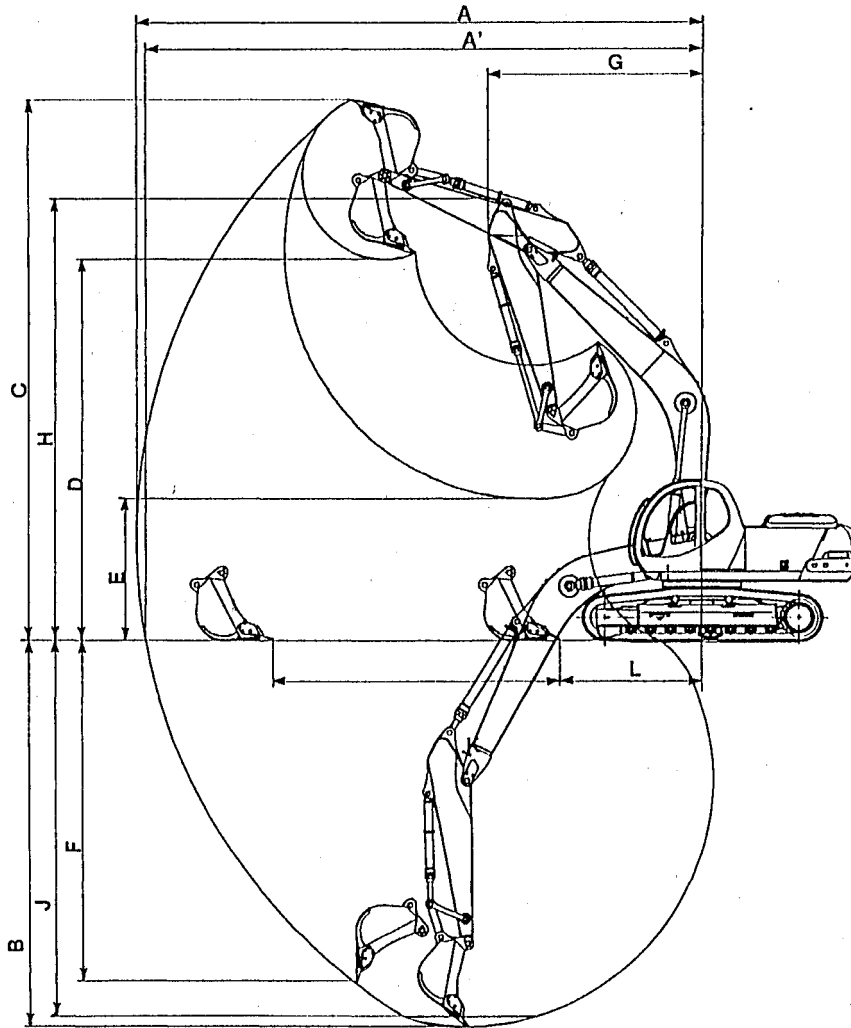

YN-6-19

Unit: m (ft-in)

Item		Attachment Type	2.5 m (8 ft-2 in) arm with 1.0 m ³ (1.31 cuyd) bucket	2.98 m (9 ft-9 in) arm with 0.9 m ³ (1.18 cuyd) bucket	3.66 m (12 ft) arm with 0.7 m ³ (0.92 cuyd) bucket
A: Maximum digging radius			9.89 (32' 5")	10.31 (33' 10")	10.97 (36')
A': Maximum reach at ground level			9.72 (31' 11")	10.14 (33' 3")	10.81 (35' 6")
*B: Maximum digging depth			6.53 (21' 5")	7.01 (23')	7.69 (25' 3")
*C: Maximum digging height			9.63 (31' 7")	9.77 (32' 1")	10.17 (33' 4")
*D: Maximum dumping height			6.71 (22')	6.87 (22' 6")	7.25 (23' 9")
*E: Minimum dumping height			3.02 (9' 11")	2.54 (8' 4")	1.86 (6' 1")
*F: Vertical digging depth			5.83 (19' 2")	6.18 (20' 3")	6.79 (22' 3")
G: Minimum swing radius			3.94 (12' 11")	3.90 (12' 9")	4.00 (13' 1")
*H: Height at minimum swing			8.03 (26' 4")	7.96 (26' 1")	7.92 (26')
*J: 8-foot level digging depth			6.33 (20' 9")	6.83 (22' 5")	7.54 (24' 9")
K	Horizontal digging distance	Stroke	4.20 (13' 9")	5.26 (17' 3")	6.58 (21' 7")
L		Minimum	3.23 (10' 7")	2.58 (8' 6")	1.93 (6' 4")

NOTE: Dimensions marked * do not include the height of the shoe lug.

● FACE SHOVEL ATTACHMENT

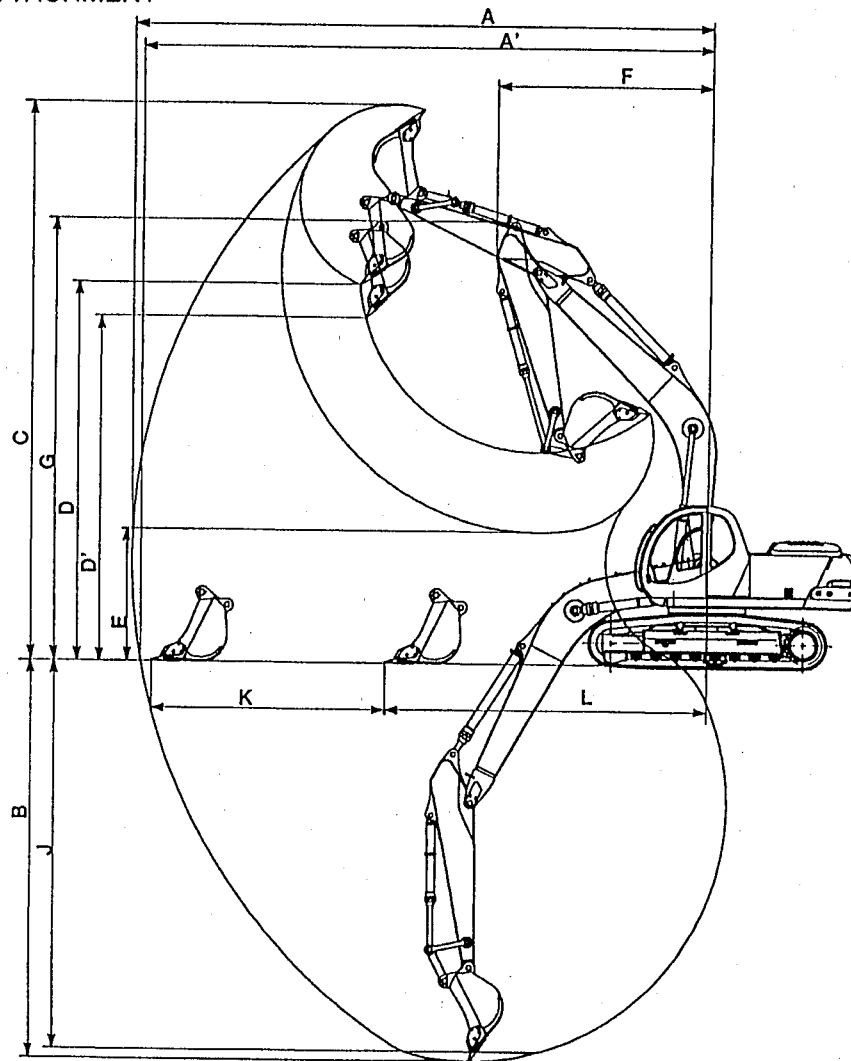

YN-6-20

Unit: m (ft-in)

Attachment Type		2.5 m (8 ft-2 in) arm with 1.0 m ³ (1.31 cuyd) bucket	2.98 m (9 ft-9 in) arm with 0.9 m ³ (1.18 cuyd) bucket	3.66 m (12 ft) arm with 0.7 m ³ (0.92 cuyd) bucket
Item				
A : Maximum digging radius		10.07 (33')	10.49 (34' 5")	11.15 (36' 7")
A' : Maximum reach at ground Level		9.90 (32' 6")	10.33 (33' 11")	11.00 (36' 1")
* B : Maximum digging depth		6.71 (22')	7.19 (23' 7")	7.87 (25' 10")
* C : Maximum digging height		9.92 (32' 7")	10.08 (33' 1")	10.46 (34' 4")
* D : Maximum dumping height		6.65 (21' 10")	6.79 (22' 3")	7.19 (23' 7")
* D' : Maximum dumping height (45°)		6.05 (19' 10")	6.18 (20' 3")	6.37 (20' 11")
* E : Minimum dumping height		2.84 (9' 4")	2.36 (7' 9")	1.68 (5' 6")
F : Minimum swing radius		3.94 (12' 11")	3.90 (12' 10")	4.00 (13' 1")
* G : Height at minimum swing		8.03 (26' 4")	7.96 (26' 1")	7.92 (26')
* J : 8-foot level digging depth		6.52 (21' 5")	7.02 (23')	7.73 (25' 4")
K	Horizontal digging distance	Stroke	3.51 (11' 6")	4.26 (14')
L		Minimum	6.21 (20' 4")	5.87 (19' 3")

NOTE: Dimensions marked * do not include the height of the shoe lug.

7. LIFTING-UP ABILITY DIAGRAM

(1) Calculation condition

The lifting-up ability of this drawing is indicated by metric standard. The indicated figures fall within 87% of a set pressure of the main relief valve used in the arm and the boom cylinder and 75% of static tilting load.

- 1) The load point is the fulcrum of the bucket and the bucket position is an embraced posture.
- 2) The figures on the upper stage indicate the lifting-up ability of a machine facing sideways, while the figures at the bottom stage represent a machine facing longitudinally.
- 3) Unit : ton Shoe width : 600mm (24") shoe

⚠ Do not use the power boost switch while lifting a load.

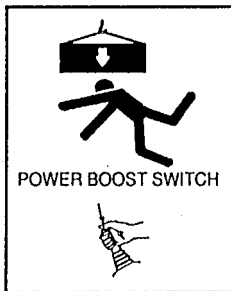

⚠ WARNING

Releasing power boost switch while lifting a load can cause unexpected lowering of load, resulting in severe injury or death.

Never use power boost switch for lifting a load.

YN20T01004P1

Attached to the right side of the cab interior

(2) Lifting-up ability diagram Item No. table

Model	Pressure kgf/cm ² (psi)	Arm M (ft-in) + Bucket M ³ (cuyd)		
		2.5M (8'2") Arm + 1.0M ³ (1.38 cuyd) Bucket	2.98M (9'9") Arm + 0.9M ³ (1.17 cuyd) Bucket	3.66M (12') Arm + 0.9M ³ (1.17 cuyd) Bucket
		600 mm shoe (24 in)	600 mm shoe (24 in)	600 mm shoe (24 in)
SK220 v	350 (4980)	1	3	5
	370 (5260)	2	4	—
SK220LC v	350 (4980)	6	8	10
	370 (5260)	7	9	—

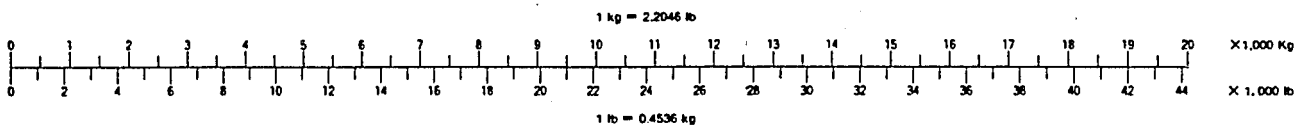

(1) Unit : ton

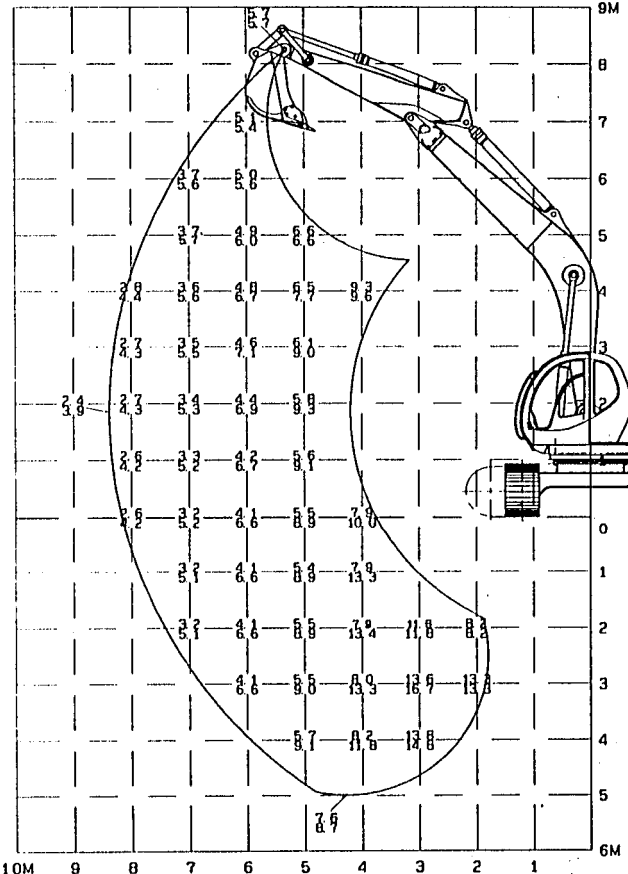

(2) Unit : ton

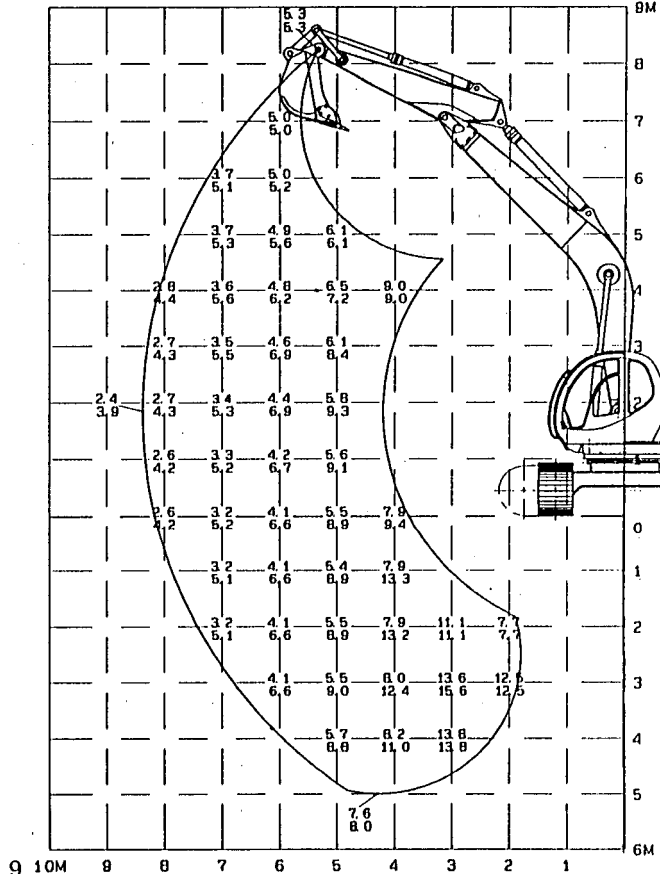

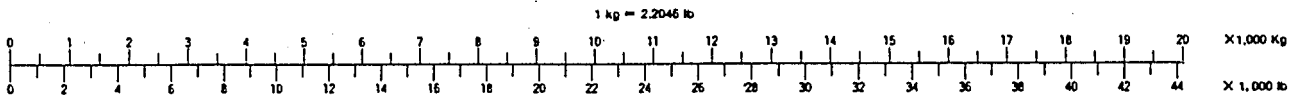

1 lb = 0.4536 kg

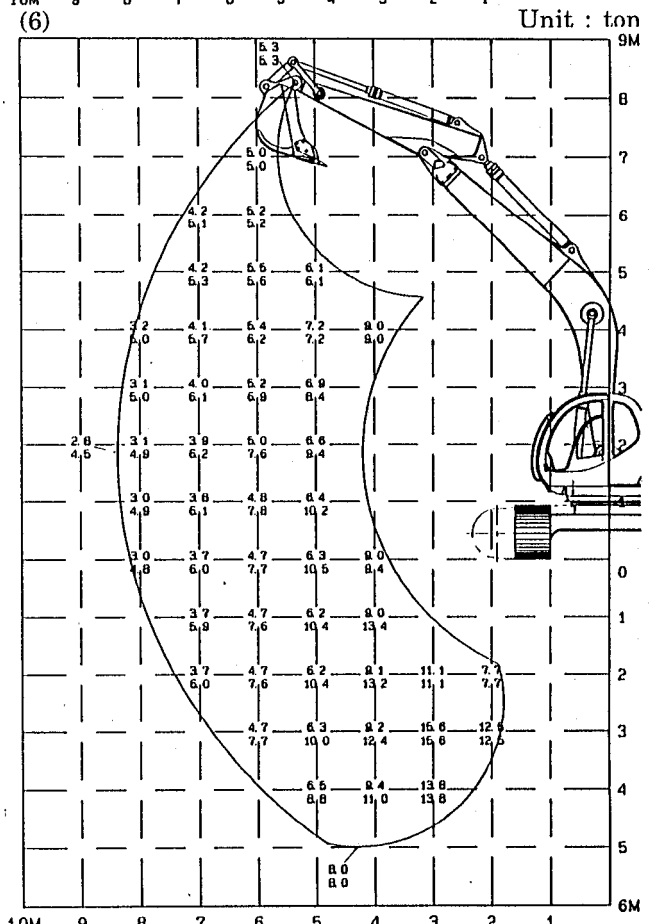
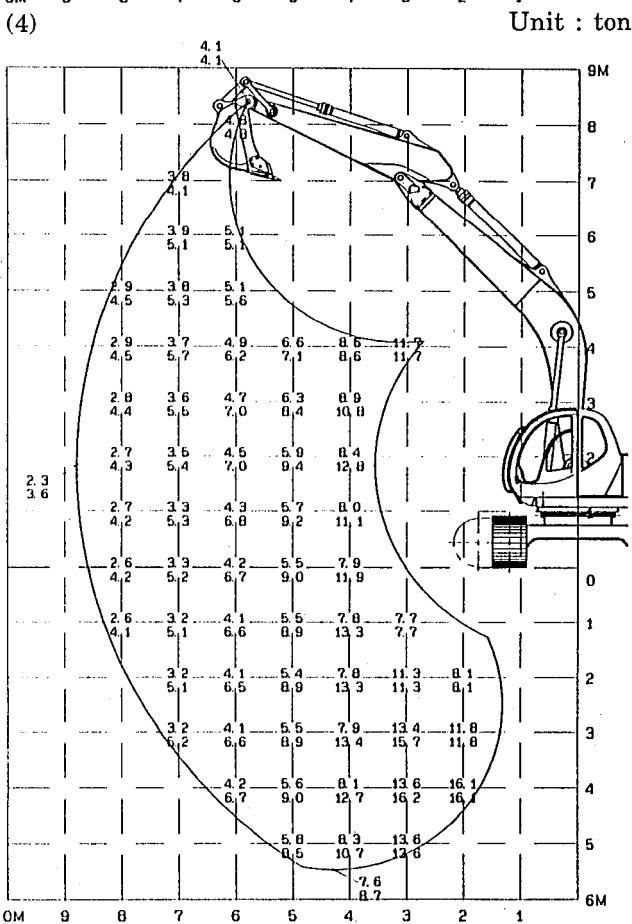
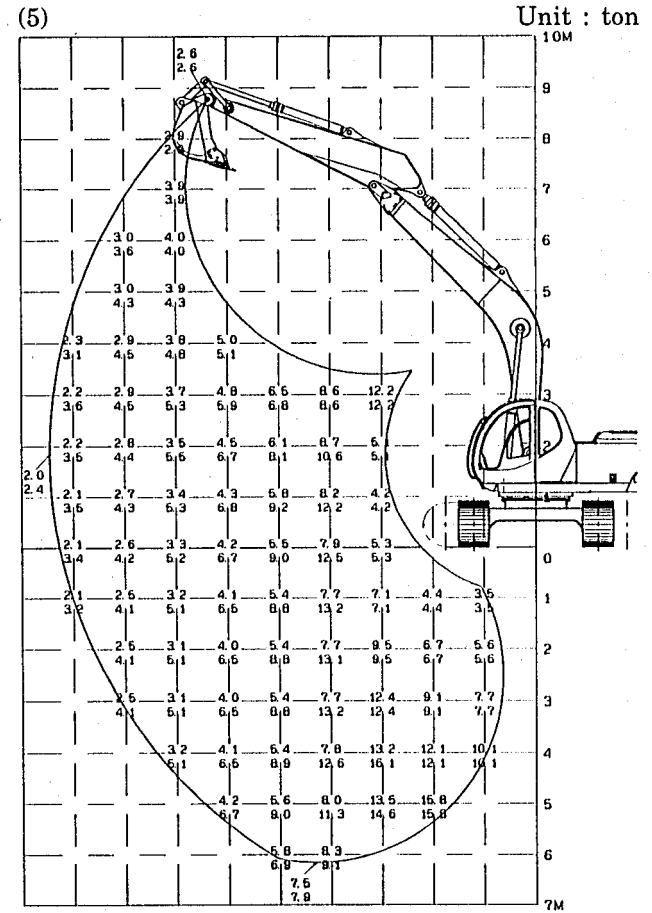
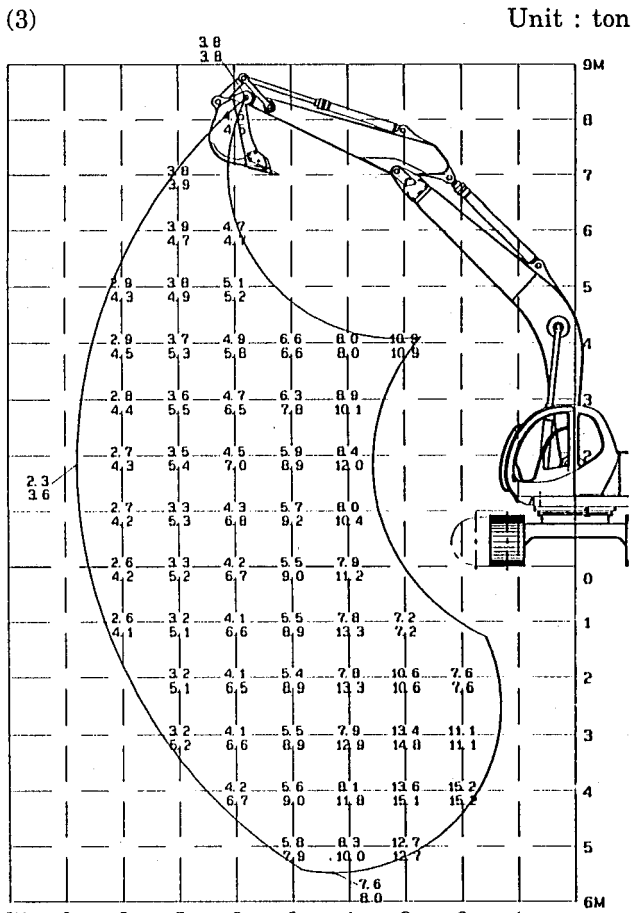

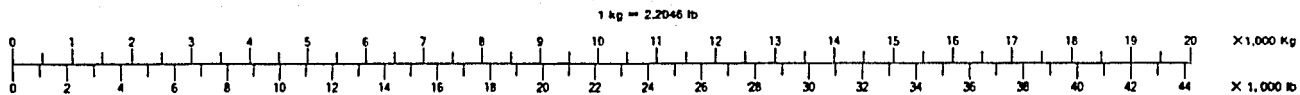

1 lb = 0.4536 kg

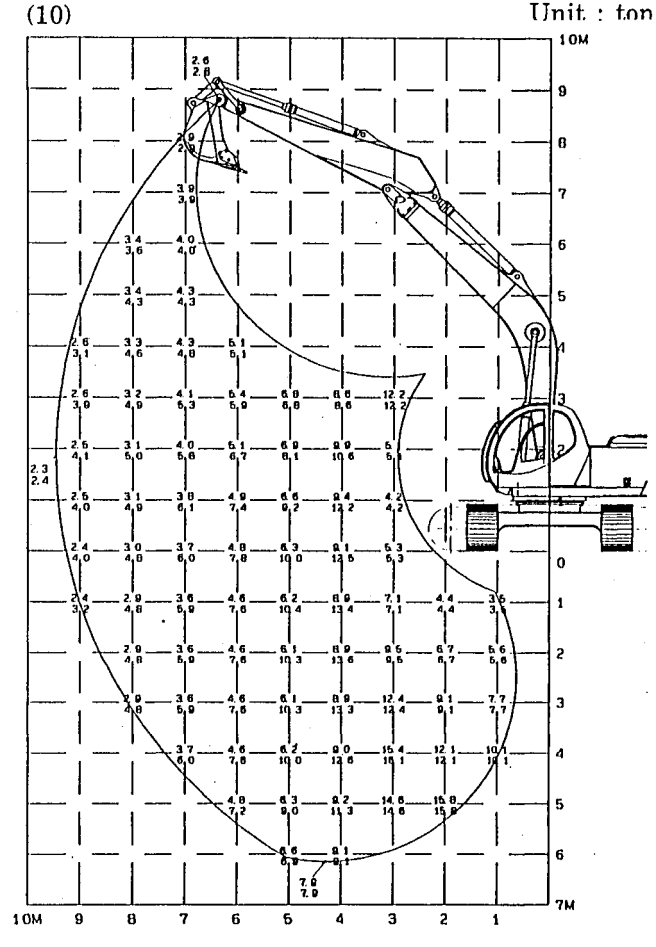
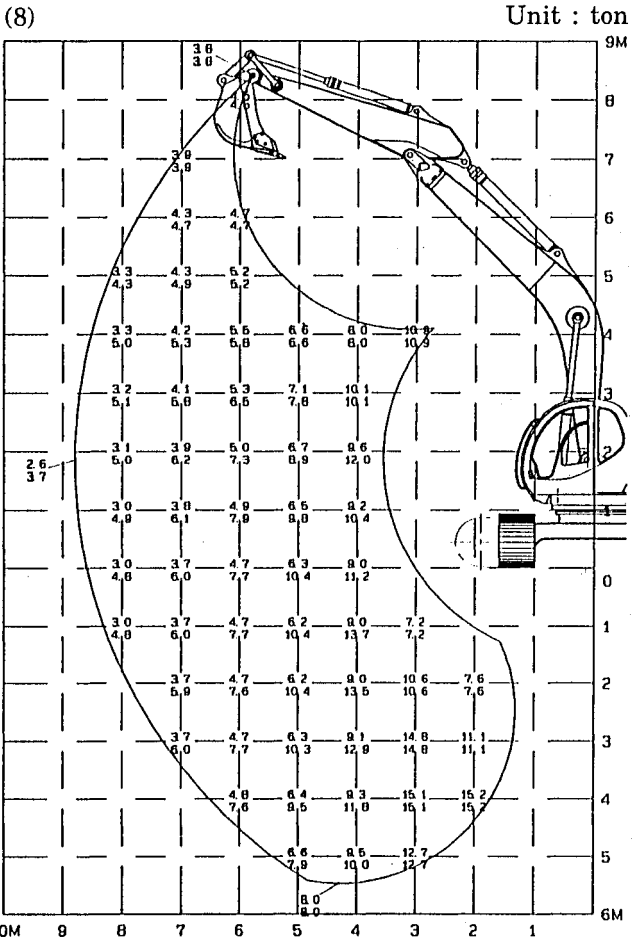
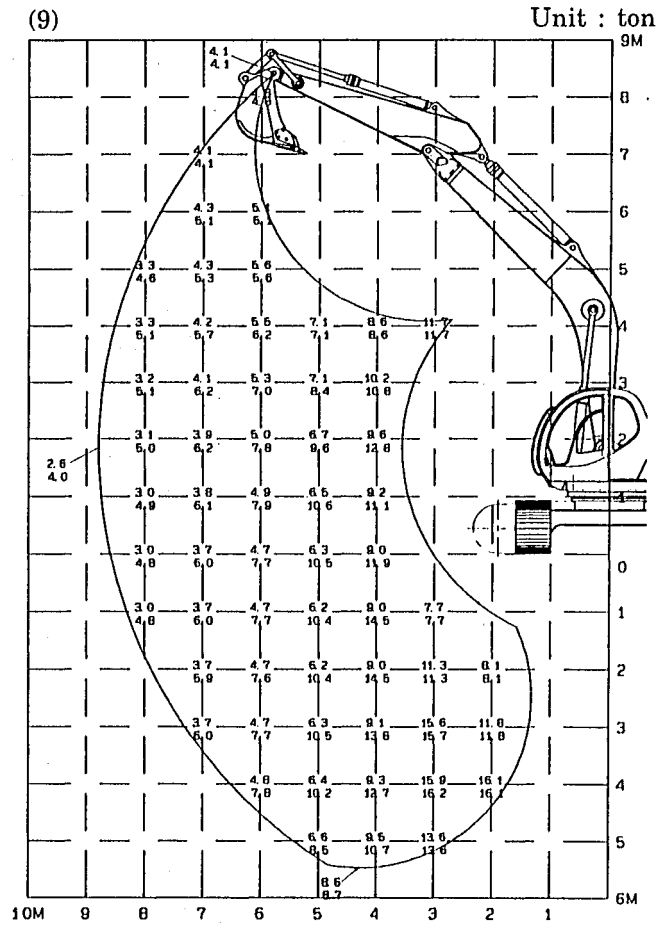
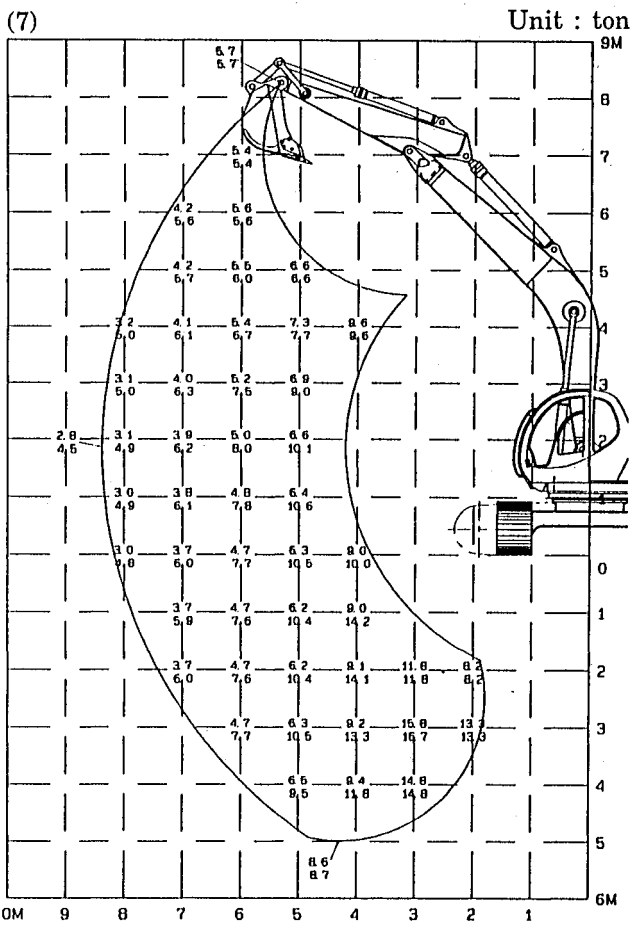

8. ENGINE SPECIFICATIONS

MAJOR SPECIFICATIONS

SK220 v , SK220LC v				
Model	Mitsubishi 6D15-T (Turbocharged)			
Type	Diesel, 4-cycle water-cooled, in-line, Direct injection			
No. of cylinders-Dir×Stroke	6-113mm×115mm (4.45 in×4.53 in)			
Total displacement	6,919cc (422 cuin)			
Compression ration	16.0			
Output rating	165PS / 2,200 rpm (121kw/ 2,200 rpm)			
Max. torque	60kgf·m / 1,700 rpm (588 N-m / 1,700 rpm)			
High idling	2,300±20 rpm			
Low idling	850±20 rpm			
Injection start pressure	180kgf/cm ² (3,130psi)			
Thermostat temperature	Valve opening 76.5°C Full open 90°C			
Ignition order	1-5-3-6-2-4			
Compression pressure	26kgf/cm ² (370psi) [at 200 rpm]			
Lube oil pressure	Rating 3~4kgf/cm ² (43~57psi)			
Fuel injection timing	16°C before the top dead point			
Valve clearance, valve action timing		Valve clearance	Open	Close
	Suction valve	In cold state, in cold condition 0.4mm (0.016")	21° before the top dead point	39° before the bottom dead point
	Exhaust valve	In cold state, in cold condition 0.4mm (0.016")	62° before the bottom dead point	18° before the top dead point
Starter capacity	4.5kw×24V			
Generator capacity	800W (30A)×24V			
Super Charging type	Turbo type			
Cooling fan drive method	Ø650 (Ø25.6in)suction type Belt drive pulley ratio:1.00			
Engine oil volume	24ℓ (6.34gal) + 4ℓ (1.06gal) (Oil filter)			
Dry weight	590kg (1,300 lbs)			
Fuel consumption rate	165 g/ps·h			
Allowable tilting angles	Back and forth, right and left 35°			
Engine dimension L×W×H	1398×750×1003 mm (55.0×29.5×39.5 in)			
Rotating direction	Counterclockwise as seen from flywheel side			