

HYDRAULIC EXCAVATOR

SHOP MANUAL

model

SK 15SR SK 20SR

This is the shop manual for KOBELCO hydraulic excavator. Contained is the necessary technical data concerning the maintenance and repair of this model. The manual is divided into the following four major sections ; GENERAL, SYSTEMS, COMPONENTS and PROCEDURE.

*GENERAL

- | | | | |
|-------|---|-------|---|
| PM01. | SPECIFICATION | PM04. | MAINTENANCE STANDARD AND TEST PROCEDURE |
| — | OPERATION AND CONTROLS
(Refer to Operators Manual) | — | PREVENTIVE MAINTENANCE
(Refer to Operators Manual) |
| PM03. | LOCATION AND WEIGHT OF COMPONENTS | PM07. | WORKING STANDARD |

*SYSTEMS

- | | | | |
|-------|------------------|-------|------------------|
| PM12. | HYDRAULIC SYSTEM | PM22. | CONTROL SYSTEM |
| PM15. | UPPER STRUCTURE | PM25. | ELECTRIC SYSTEM |
| PM18. | TRAVEL SYSTEM | | |
| PM21. | ATTACHMENTS | PM29. | TROUBLE SHOOTING |

*COMPONENTS

- | | | | |
|-----|-----------------|-----|--------------------|
| 12. | HYDRAULIC PUMP | 16. | SWIVEL JOINT |
| 13. | CONTROL VALVE | 17. | HYDRAULIC CYLINDER |
| 14. | OTHER VALVES | | |
| 15. | HYDRAULIC MOTOR | 50. | ENGINE |

*PROCEDURE

When checking or repairing the machine we suggest that you refer to this manual carefully. We hope that reference to this manual will help to maintain a high level of working efficiency and reliability. For further details on maintenance and checks refer to the "OPERATORS MANUAL" which has been supplied with the machine.

Although all data was correct at the time of printing, due to continual design changes and improvements, some contents may not conform to the actual machine. Take special care to order parts only after confirming the validity of the part number in the "PARTS MANUAL".

If you notice any explanatory discrepancies, after consulting one of our representatives, please update your manual according to the latest data. However, in the event of any specification changes, we will issue revised edition.

INDEX

KOBELCO

Book code No. S5PM0002E②

SK15SR List of Shop Manual GENERAL Section
 SK20SR

Index No.	Title	Book Code No.		
		Distribution Year - Month		
	Applicable Machines	SK15SR PU06001~07000 ※PU07001~	SK20SR PM02001~03500 ※PM03501~	
PM01	SPECIFICATION	S5PM0101E② 1999-4	←	
—	OPERATION	S2PM1003E① ※S2PM1004E Refer to Operators manual	←	
PM03	LOCATION AND WEIGHT OF COMPONENTS	S5PM0301E① 1999-4	←	
PM04	MAINTENANCE STANDARDS AND TEST PROCEDURES	S5PM0401E① 1999-4	←	
—	—	—	—	
—	PREVENTIVE MAINTENANCE	S2PM0003E① ※S2PM1004E Refer to Operators manual	←	
PM07	WAOPKING STANDARDS	S5PM0701E 1997-5	←	

- First edition : May, 1997
- First revision : March, 1998
- Second revision : April, 1999

WARNING

13. Always use tools that are in good condition and be sure you understand how to use them before performing any service work.
 14. Reinstall all fasteners with same part number. Do not use a lesser quality fastener if replacements are necessary.
 15. Repairs which require welding should be performed only with the benefit of the appropriate reference information and by personnel adequately trained and knowledgeable in welding procedures. Determine type of metal being welded and select correct welding procedure and electrodes, rods or wire to provide a weld metal strength equivalent at least to that of parent metal. Always disconnect battery during welding operations to protect sensitive electric equipment.
 16. Do not damage wiring during removal operations. Reinstall the wiring so it is not damaged nor will it be damaged in operation by contacting sharp corners, or by rubbing against some object or hot surface. Do not connect wiring to a line containing fluid.
 17. Be sure all protective devices including guards and shields are properly installed and functioning correctly before starting a repair. If a guard or shield must be removed to perform the repair work, use extra caution.
 18. Loose or damaged fuel, lubricant and hydraulic lines, tubes and hoses can cause fires. Do not bend or strike high pressure lines or install ones which have been bent or damaged. Inspect lines, tubes and hoses carefully. Do not check for leaks with your hands. Pin hole (very small) leaks can result in a high velocity oil stream that will be invisible close to the hose. This oil can penetrate the skin and cause personal injury. Use cardboard or paper to locate pin hole leaks.
 19. Tighten connections to the correct torque. Make sure that all heat shields, clamps and guards are installed correctly to avoid excessive heat, vibration or rubbing against other parts during operation. Shields that protect against oil spray onto hot exhaust components in event of a line, tube or seal failure must be installed correctly.
 20. Do not operate a machine if any rotating part is damaged or contacts any other part during operation. Any high speed rotating component that has been damaged or altered should be checked for balance before reusing.
 21. On track-type machines, be careful when servicing or separating tracks. Chips can fly when removing or installing a track pin. Wear safety glasses and long sleeve shirts. Track can unroll very quickly when separated. Keep away from front and rear of machine. The machine can move unexpectedly when both tracks are disengaged from the sprockets. Block the machine to prevent it from moving.
 22. Caution should be used to avoid breathing dust that may be generated when handling components containing asbestos fibers. If this dust is inhaled, it can be hazardous to your health. Components in KOBELCO products that may contain asbestos fibers are brake pads, brake band and lining assemblies, clutch plates and some gaskets. The asbestos used in these components is usually bound in a resin or sealed in some way. Normal handling is not hazardous as long as airborne dust which contains asbestos is not generated.
- If dust which may contain asbestos is present, there are several common sense guidelines that should be followed.
- a. Never use compressed air for cleaning.
 - b. Avoid brushing or grinding of asbestos containing materials.
 - c. For clean up, use wet methods or a vacuum equipped with a high efficiency particulate air (HEPA) filter.
 - d. Use exhaust ventilation on permanent machining jobs.
 - e. Wear an approved respirator if there is no other way to control the dust.
 - f. Comply with applicable rules and regulations for the work place.
 - g. Follow environmental rules and regulations for disposal of asbestos.
 - h. Avoid areas where asbestos particles may be in the air.

SHOP MANUAL

model **SK 15SR** **SK 20SR**

TABLE OF CONTENTS

1. SPECIFICATION
2. OPERATION AND CONTROLS (Refer to Operators Manual)
3. LOCATION AND WEIGHT OF COMPONENTS
4. MAINTENANCE STANDARDS AND TEST PROCEDURES
5.
6. PREVENTIVE MAINTENANCE (Refer to Operators Manual)
7. WORKING STANDARDS
8.

PM01

PM03

PM04

PM07

○How to Index each Shop Manual Section

The GENERAL of this shop manual consists of 8 headings as shown above. Each section can be easily referred to by indexes appended to the margin of the page as indicated on the right. Please use the indexes for speedy reference.

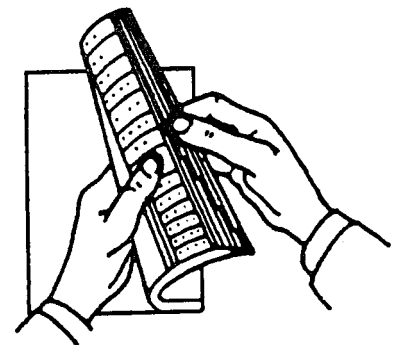

KOBELCO

GENERAL

SK15SR List of Shop Manual GENERAL Section
SK20SR

Index No.	Title	Book Code No.		
		Distribution Year - Month		
	Applicable Machines	SK15SR PU06001~07000 ※PU07001~	SK20SR PM02001~03500 ※PM03501~	
PM01	SPECIFICATION	S5PM0101E② 1999-4	←	
—	OPERATION	S2PM1003E① ※S2PM1004E Refer to Operators manual	←	
PM03	LOCATION AND WEIGHT OF COMPONENTS	S5PM0301E① 1999-4	←	
PM04	MAINTENANCE STANDARDS AND TEST PROCEDURES	S5PM0401E① 1999-4	←	
—	—	—	—	
—	PREVENTIVE MAINTENANCE	S2PM0003E① ※S2PM1004E Refer to Operators manual	←	
PM07	WAOPKING STANDARDS	S5PM0701E 1997-5	←	

- First edition : May, 1997
- First revision : March, 1998
- Second revision : April, 1999

KOBELCO

Book Code No.

S5PM01^{01E②}

SHOP MANUAL

SK15SR SK20SR

SPECIFICATION

PM01

TABLE OF CONTENTS

1. NAME OF COMPONENTS	1
2. GENERAL DIMENSIONS	2
3. SPECIFICATIONS AND PERFORMANCE	4
4. TYPE OF SHOES	6
5. TYPE OF BUCKETS	6
6. WORKING RANGES OF ATTACHMENTS	7
7. LIFTING DIAGRAM	9
8. ENGINE SPECIFICATIONS	14
9. ENGINE PERFORMANCE CURVES	15

Applicable Machines

SK15SR : PU06001~

SK20SR : PM02001~

Revision	Date of Issue	Remarks
First edition	May, 1997	S5PM0101E S
First revision	March, 1998	S5PM0101E① S
Second revision	April, 1999	S5PM0101E② S

1. NAME OF COMPONENTS

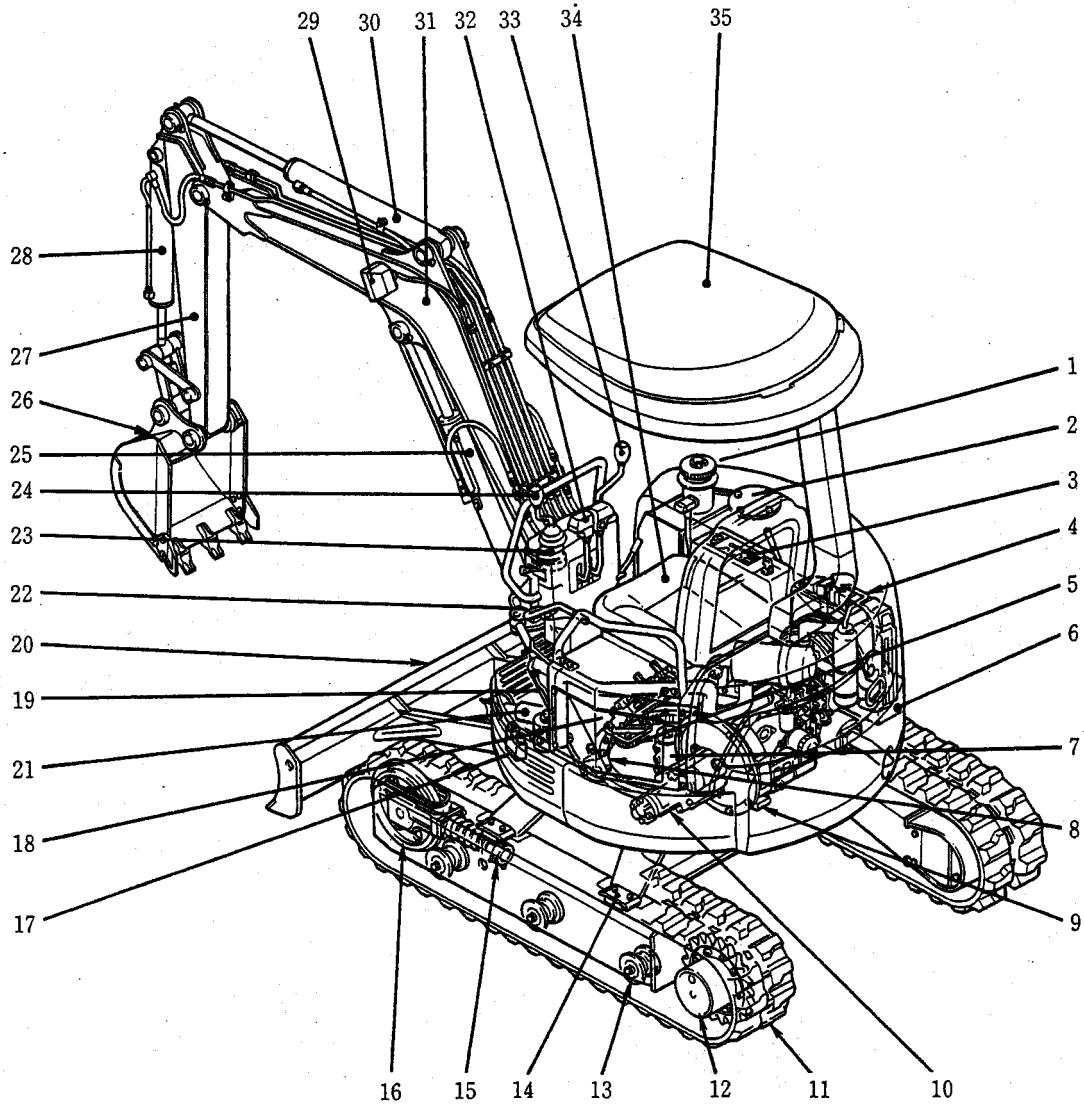

- | | | |
|--------------------|------------------------|-------------------------|
| ① FUEL TANK | ⑬ LOWER ROLLER | ⑳ BOOM CYLINDER |
| ② HYDRAULIC TANK | ⑭ SHOE SLIDE | ㉑ BUCKET |
| ③ INSTRUMENT PANEL | ⑮ TRACK ADJUSTER | ㉒ ARM |
| ④ RADIATOR | ⑯ IDLER | ㉓ BUCKET CYLINDER |
| ⑤ SLEWING MOTOR | ⑰ SOLENOID VALVE | ㉔ WORKING LIGHT |
| ⑥ BATTERY | ⑱ CONTROL VALVE | ㉕ ARM CYLINDER |
| ⑦ SWIVEL JOINT | ⑲ SWING CYLINDER | ㉖ BOOM |
| ⑧ SLEWING RING | ㉑ DOZER BLADE | ㉗ TRAVEL LEVER |
| ⑨ ENGINE | ㉒ DOZER BLADE CYLINDER | ㉘ RIGHT OPERATING LEVER |
| ⑩ HYDRAULIC PUMP | ㉓ SAFETY LEVER | ㉙ OPERATOR SEAT |
| ⑪ RUBBER SHOE | ㉔ PILOT VALVE | ㉚ CANOPY |
| ⑫ TRAVELING MOTOR | ㉕ LEFT OPERATING LEVER | |

2. GENERAL DIMENSIONS

■ SK15SR (CANOPY SPEC.)

Unit : mm (ft-in)

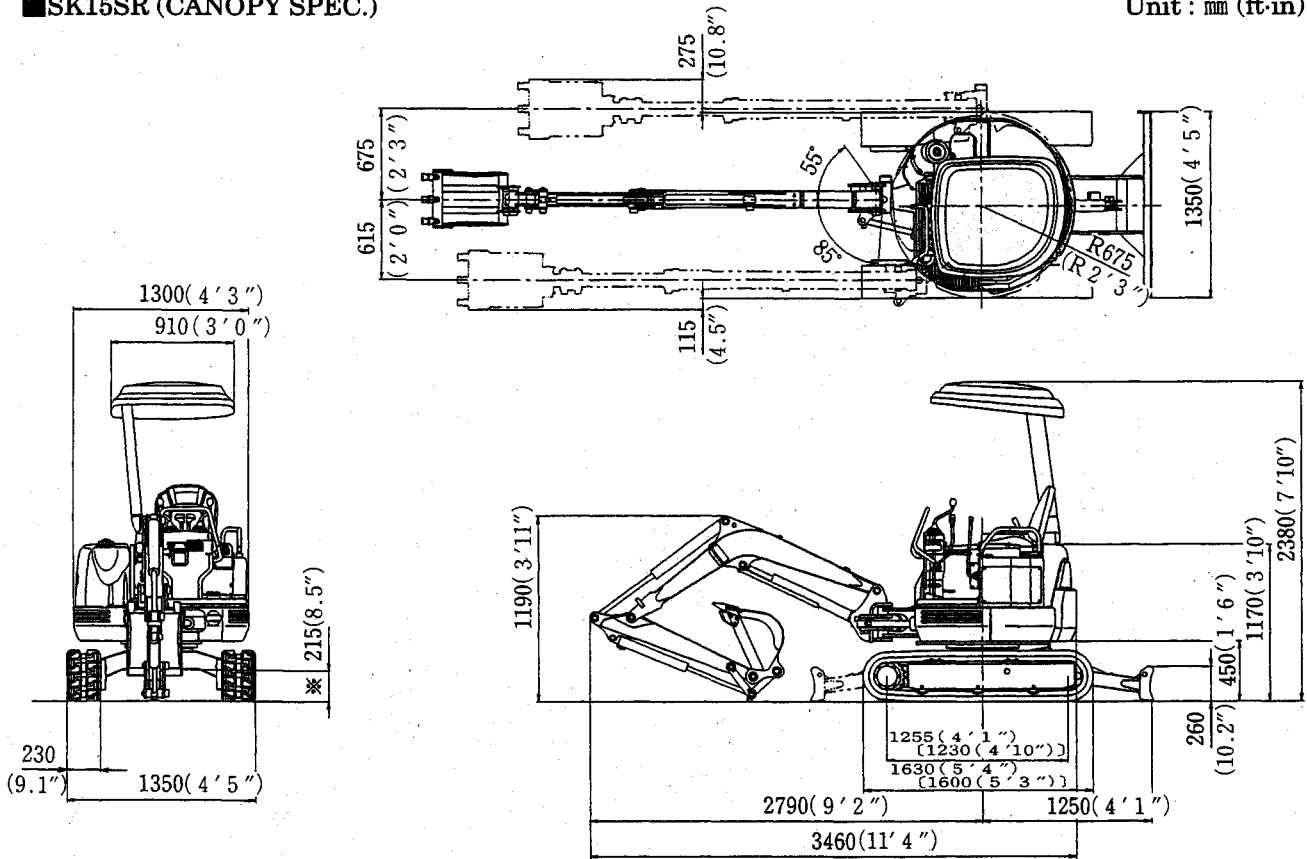

■ SK15SR (CAB SPEC.)

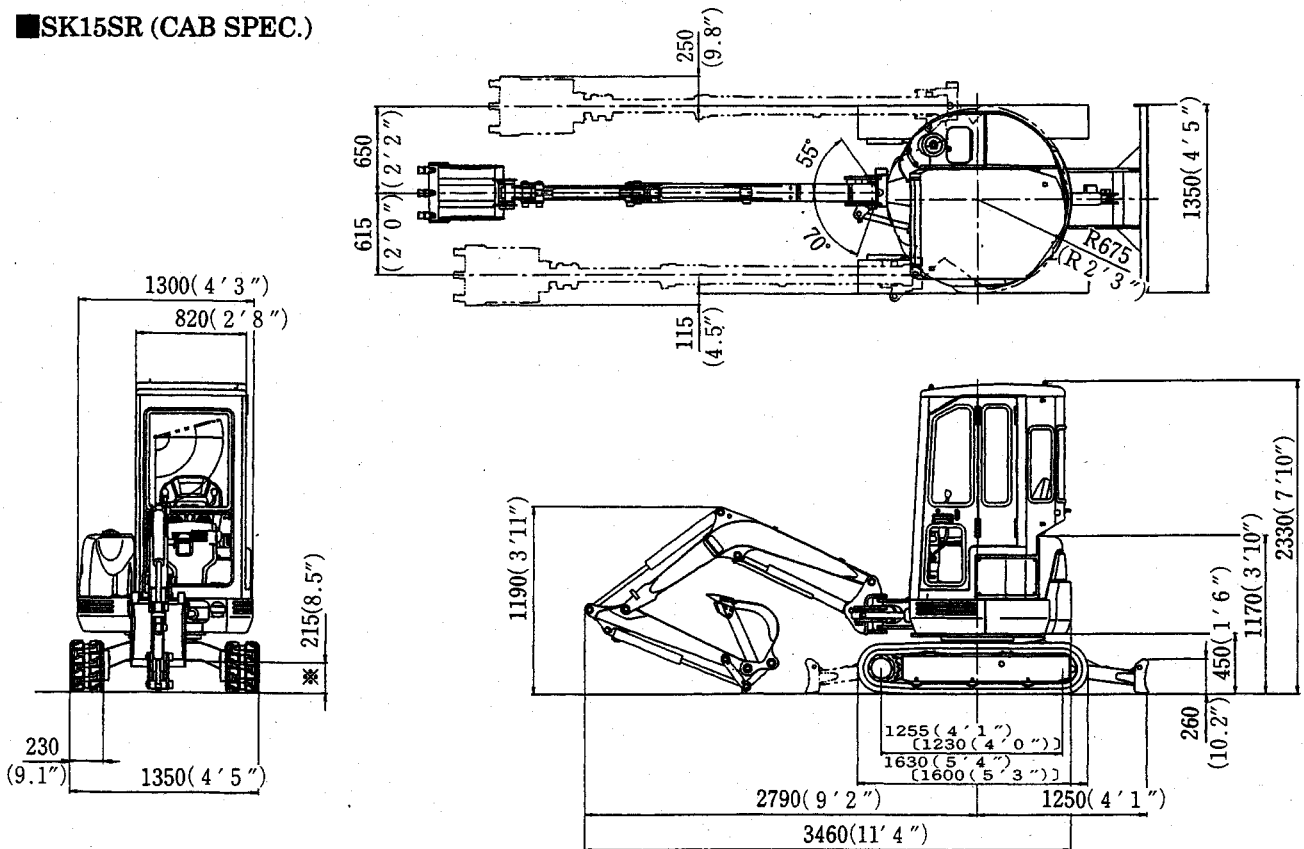

NOTE : Numerical values marked * do not include the height of the shoe lug.
 Numerical values enclosed in parentheses [] indicate steel crawler specifications.

■ R.O.P.S. CANOPY (U.S.A. Only)

Unit : mm (ft-in)

■ SK15SR

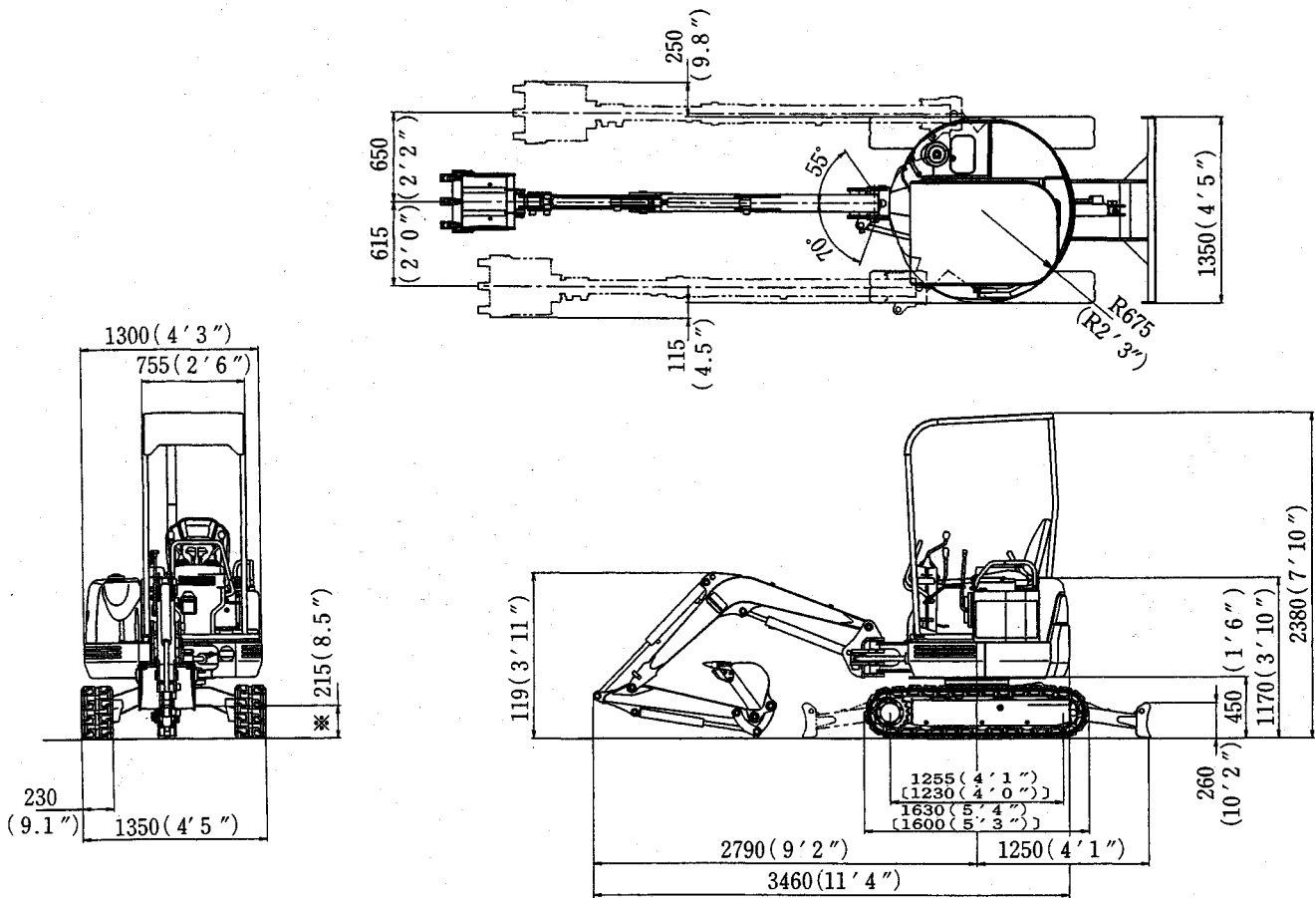

NOTE : Numerical values marked * do not include the height of the shoe lug.
Numerical values enclosed in parentheses [] indicate steel crawler specifications.

Because of an editrial convenience, this page is made blank.

3. SPECIFICATIONS AND PERFORMANCE

● SPEED AND GRADABILITY

Model		SK15SR							
Applicable Machines		PU06001~PU07000				PU07001~			
Item	Shoe Type	Rubber		Steel		Rubber		Steel	
Slewing Speed	rpm	9.4							
Travel Speed	km/h (mph)	Low	High	Low	High	Low	High	Low	High
		2.1 (1.3)	4.2 (2.6)	2.0 (1.2)	4.0 (2.5)	2.2 (1.4)	4.0 (2.5)	2.0 (1.2)	3.7 (2.3)
Gradability		30°(58%)							

● ENGINE

Item	Model	SK15SR
Model		3TNE72A-UYBB
Type		4-Cycle, vertical, water-cooled, 3-cylinder
Number of Cylinders- Bore×Stroke		3 - 72mm×72mm (2.83in×2.83in)
Total Displacement	cc (cu.in)	879 (53.64)
Rated Output/Rotation Speed	Ps/rpm	14.5/2,350
Maximum Torque/Rotation	kgf·m (ft·lbs)/rpm	5.2 (38) /1,700
Starter		12V/1.0kW
Alternator		12V/20A

● HYDRAULIC COMPONENTS

Item	Model	SK15SR
Hydraulic Pump		Gear pump
Hydraulic Motor (Slewing)		Orbit motor
Hydraulic Motor (Travel)		Axial piston, 2-speed motor
Control Valve		8-functions multiple control valve
Cylinder (Boom, Arm, Bucket, Swing, Dozer blade)		Double action cylinder
Return filter		Safety valve containing filter type (10 μ)

● SIDE DIGGING

Item	Model	SK15SR
Type		Boom swing by hydraulic cylinder
Boom Swing Angle	Canopy	55°(Right) / 85°(Left)
	Cab	55°(Right) / 70°(Left)

● SPEED AND GRADABILITY

Model		SK20SR							
Applicable Machines		PM02001~PM03500				PM03501~			
Item	Shoe Type	Rubber		Steel		Rubber		Steel	
Slewing Speed	rpm	8.7							
Travel Speed	km/h (mph)	Low	High	Low	High	Low	High	Low	High
		2.5 (1.6)	4.9 (3.0)	2.3 (1.4)	4.6 (2.9)	2.5 (1.6)	4.3 (2.3)	2.4 (1.5)	4.0 (2.5)
Gradability		30°(58%)							

● ENGINE

Item	Model	SK20SR
Model		3TNE72A-UYB
Type		4-Cycle, vertical, water-cooled, 3-cylinder
Number of Cylinders- Bore×Stroke		3 - 72mm×72mm (2.83in×2.83in)
Total Displacement	cc (cu.in)	879 (53.64)
Rated Output/Rotation Speed	Ps/rpm	14.5/2,350
Maximum Torque/Rotation	kgf·m (ft·lbs)/rpm	5.2 (38) /1,700
Starter		12V/1.0kW
Alternator		12V/20A

● HYDRAULIC COMPONENTS

Item	Model	SK20SR
Hydraulic Pump		Variable displacement axial piston + gear pump
Hydraulic Motor (Slewing)		Orbit motor
Hydraulic Motor (Travel)		Axial piston, 2-speed motor
Control Valve		9-functions multiple control valve
Cylinder (Boom, Arm, Bucket, Swing, Dozer blade)		Double action cylinder
Return filter		Safety valve containing filter type (10 μ)

● SIDE DIGGING

Item	Model	SK20SR
Type		Boom swing by hydraulic cylinder
Boom Swing Angle	Canopy	55°(Right) / 85°(Left)
	Cab	55°(Right) / 70°(Left)

● WEIGHT (CANOPY SPEC.)

Model		SK15SR			
Applicable Machines		PU06001~PU07000		PU07001~	
Item	Shoe Type	Rubber	Steel	Rubber	Steel
Fully-equipped weight	kg (lbs)	1,580(3,480) [1,610(3,550)]	1,640(3,620) [1,670(3,680)]	1,650(3,640) [1,680(3,700)]	1,660(3,660) [1,690(3,730)]
Upper machinery	kg (lbs)	885(1,950) [915(2,020)]		←	
Lower machinery	kg (lbs)	530 (1,170)	590 (1,300)	600 (1,320)	610 (1,350)
Attachment (S. T. D) Boom + Arm + Bucket	kg (lbs)	165 (360) 1.78m+0.92m+0.044m ³ (5'10"+3'0"+0.058cu.yd)			
Dozer Blade	width×height	1,350mm×260mm (4'5"×10.2")			
Strokes of Blade	up/down	280mm/270mm (11"/10.6")			

NOTE : Valves in [] are for R.O.P.S. Canopy (U.S.A. Only).

● WEIGHT (CAB SPEC.)

Model		SK15SR			
Applicable Machines		PU06001~PU07000		PU07001~	
Item	Shoe Type	Rubber	Steel	Rubber	Steel
Fully-equipped weight	kg (lbs)	1,680 (3,700)	1,740 (3,840)	1,750 (3,860)	1,760 (3,880)
Upper machinery	kg (lbs)	985 (2,170)		←	
Lower machinery	kg (lbs)	530 (1,170)	590 (1,300)	600 (1,320)	610 (1,350)
Attachment (S. T. D) Boom + Arm + Bucket	kg (lbs)	165 (360) 1.78m+0.92m+0.044m ³ (5'10"+3'0"+0.058cu.yd)			
Dozer Blade	width×height	1,350mm×260mm (4'5"×10.2")			
Strokes of Blade	up/down	280mm/270mm (11"/10.6")			

● WEIGHT (CANOPY SPEC.)

Model		SK20SR			
Applicable Machines		PM02001~PM03500		PM03501~	
Item	Shoe Type	Rubber	Steel	Rubber	Steel
Fully-equipped weight	kg (lbs)	1,900 (4,190)	1,950 (4,300)	1,970 (4,340)	←
Upper machinery	kg (lbs)	1,090 (2,400)		←	
Lower machinery	kg (lbs)	600 (1,320)	650 (1,430)	670 (1,480)	←
Attachment (S. T. D) Boom + Arm + Bucket	kg (lbs)	210 (460)			
		1.845m + 1.015m + 0.066 m ³ (6'1" + 3'4" + 0.086cu.yd)			
Dozer Blade	width × height	1,400mm × 260mm (4'7" × 10.2")			
Strokes of Blade	up/down	320mm/310mm (12.6"/12.2")			

NOTE : Valves in [] are for R.O.P.S. Canopy (U.S.A. Only).

● WEIGHT (CAB SPEC.)

Model		SK20SR			
Applicable Machines		PM02001~PM03500		PM03501~	
Item	Shoe Type	Rubber	Steel	Rubber	Steel
Fully-equipped weight	kg (lbs)	2,000 (4,410)	2,050 (4,520)	2,070 (4,560)	←
Upper machinery	kg (lbs)	1,190 (2,620)		←	
Lower machinery	kg (lbs)	600 (1,320)	650 (1,430)	670 (1,480)	←
Attachment (S. T. D) Boom + Arm + Bucket	kg (lbs)	210 (460)			
		1.845m + 1.015m + 0.066 m ³ (6'1" + 3'4" + 0.086cu.yd)			
Dozer Blade	width × height	1,400mm × 260mm (4'7" × 10.2")			
Strokes of Blade	up/down	320mm/310mm (12.6"/12.2")			

4. TYPE OF SHOES

Model	Applicable Machines	Type	Shoe Width mm (ft-in)	Total Width of Crawler mm (ft-in)	Ground Pressure kg-f/cm ² (PSI)		Weight kg (lbs)
					Canpy	Cab	
SK15SR	PU06001~ PU07000	Rubber Shoe	230	1,350	0.26(3.7)	0.28(4.0)	62(140)
		Steel Shoe	(9.1")	(4'5")	0.27(3.8)	0.29(4.1)	91(200)
	PU07001~	Rubber Shoe	230	1,350	0.27(3.8)	0.29(4.1)	87(190)
		Steel Shoe	(9.1")	(4'5")	0.27(3.8)	0.29(4.1)	92(200)
SK20SR	PM02001~ PM03500	Rubber Shoe	250	1,400	0.27(3.8)	0.28(4.0)	71(160)
		Steel Shoe	(9.8")	(4'7")	0.28(4.0)	0.29(4.1)	96(210)
	PM03501~	Rubber Shoe	250	1,400	0.28(4.0)	0.29(4.1)	96(210)
		Steel Shoe	(9.8")	(4'7")	0.28(4.0)	0.29(4.1)	96(210)

5. TYPE OF BUCKETS

Model	Heaped Capacity m ³ (cu. yd)	Outside Width of Bucket mm (ft-in)		Number of teeth	Weight kg (lbs)	Remarks
		With side cutters	Without side cutters			
SK15SR	0.022 (0.029)	300(11.8")	240(9.4")	3	28(62)	
	0.027 (0.035)	350(1'2")	290(11.4")	3	30(66)	
	0.044 (0.058)	450(1'6")	390(1'3")	3	33(73)	Standard
	0.044 (0.058)	450(1'6")	390(1'3")	4	36(79)	Heavy duty Type
	0.044 (0.058)	450(1'6")	390(1'3")	3	42(93)	(18S Tooth)
SK20SR	0.040 (0.052)	350(1'2")	285(11.2")	3	40(88)	
	0.066 (0.086)	450(1'6")	385(1'3")	3	45(99)	Standard
	0.066 (0.086)	450(1'6")	385(1'3")	4	49(108)	Heavy duty Type
	0.066 (0.086)	450(1'6")	385(1'3")	3	52(115)	(18S Tooth)

6. WORKING RANGES OF ATTACHMENTS

■ CANOPY SPEC.

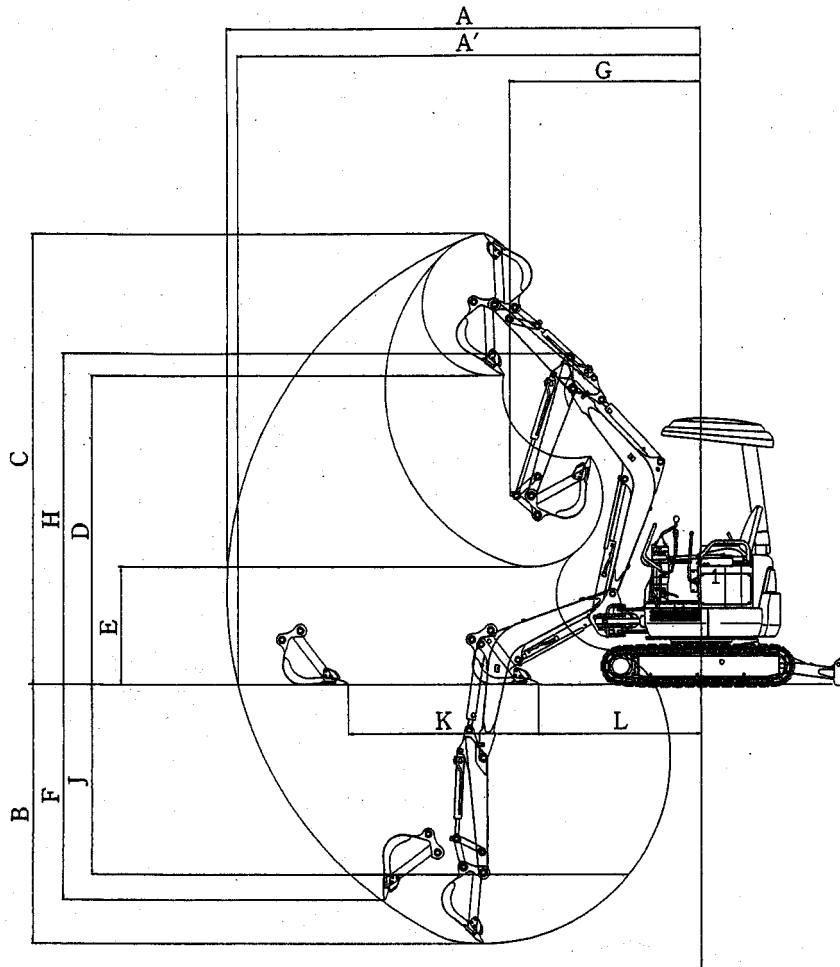

Unit : mm (ft-in)

Mark	Item	Model	SK15SR		SK20SR	
			Standard	Long	Standard	Long
	Arm Type		920 (3'0")	1,190 (3'11")	1,015 (3'4")	1,285 (4'3")
	Bucket capacity (STD)		0.044 m ³ (0.058 cu.yd)		0.066 m ³ (0.080 cu.yd)	
A	Maximum digging reach		3,930 (12'11")	4,180 (13'9")	4,170 (13'8")	4,420 (14'6")
A'	Maximum reach at ground level		3,820 (12'6")	4,090 (13'5")	4,070 (13'4")	4,330 (14'2")
※B	Maximum digging depth		2,150 (7'1")	2,480 (8'2")	2,300 (7'7")	2,560 (8'5")
※C	Maximum digging height		3,630 (11'11")	3,810 (12'6")	3,980 (13'1")	4,180 (13'9")
※D	Maximum dumping height		2,590 (8'6")	2,770 (9'1")	2,730 (8'11")	2,930 (9'7")
※E	Minimum dumping height		1,070 (3'6")	810 (2'8")	1,040 (3'5")	790 (2'7")
※F	Vertical digging depth		1,570 (5'2")	1,820 (6'0")	1,910 (6'3")	2,170 (7'1")
G	Maximum swing radius		1,610 (5'3")	1,670 (5'6")	1,680 (5'6")	1,790 (5'10")
※H	Height at minimum swing		2,790 (9'2")	←	2,930 (9'7")	←
※J	8-foot level digging depth		1,470 (4'10")	1,850 (6'1")	1,680 (5'6")	2,040 (6'8")
K	Horizontal digging stroke at ground level	Stroke	1,600 (5'3")	2,008 (6'7")	1,670 (5'6")	2,020 (6'8")
L		Minimum	1,380 (4'6")	1,220 (4'0")	1,430 (4'8")	1,340 (4'5")

NOTE : Dimensions marked ※ do not include the height of the shoe lug.

■ CAB SPEC.

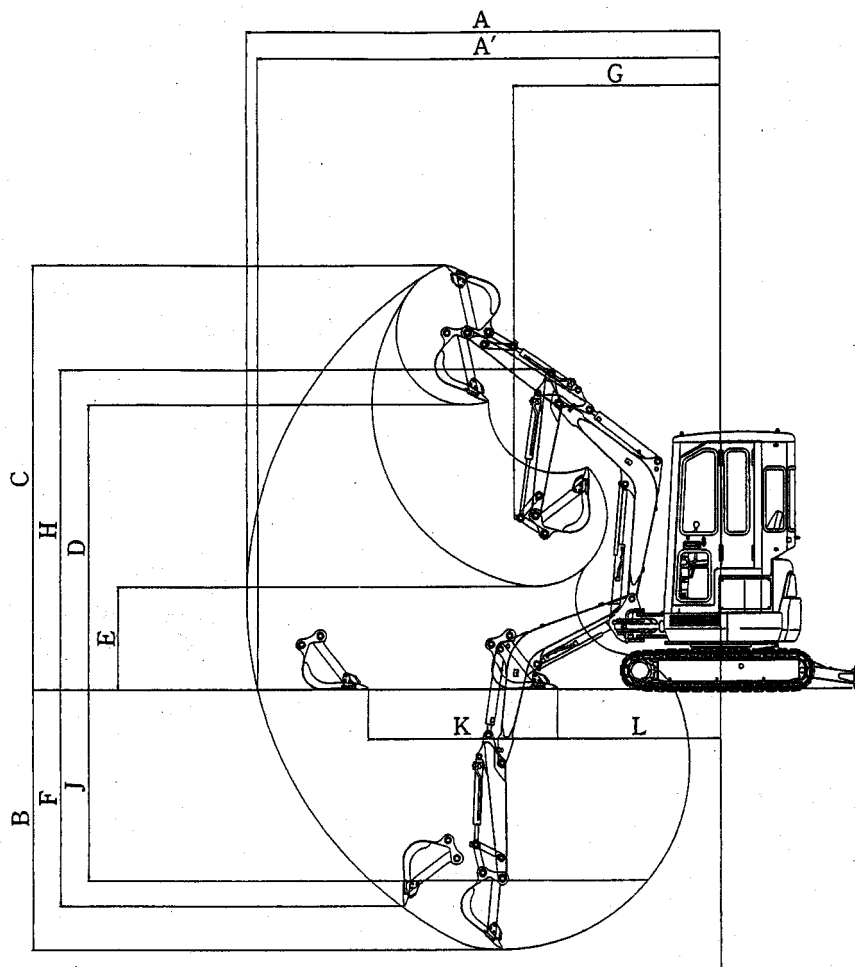

Unit : mm (ft-in)

Mark	Item	Model	SK15SR		SK20SR	
			Standard	Long	Standard	Long
	Arm Type		920 (3'0")	1,190 (3'11")	1,015 (3'4")	1,285 (4'3")
	Bucket capacity (STD)		0.044 m ³ (0.058 cu.yd)		0.066 m ³ (0.080 cu.yd)	
A	Maximum digging reach		3,930 (12'11")	4,180 (13'9")	4,170 (13'8")	4,420 (14'6")
A'	Maximum reach at ground level		3,820 (12'6")	4,090 (13'5")	4,070 (13'4")	4,330 (14'2")
※B	Maximum digging depth		2,150 (7'1")	2,480 (8'2")	2,300 (7'7")	2,560 (8'5")
※C	Maximum digging height		3,410 (11'2")	3,560 (11'8")	3,760 (12'4")	3,920 (12'10")
※D	Maximum dumping height		2,400 (7'10")	2,550 (8'4")	2,530 (8'4")	2,690 (8'10")
※E	Minimum dumping height		966 (3'2")	700 (2'4")	910 (3'0")	650 (2'2")
※F	Vertical digging depth		1,570 (5'2")	1,820 (6'0")	1,910 (6'3")	2,170 (7'1")
G	Maximum swing radius		1,730 (5'8")	1,750 (5'9")	1,810 (5'11")	1,880 (6'2")
※H	Height at minimum swing		2,690 (8'10")	←	2,840 (9'4")	←
※J	8-foot level digging depth		1,470 (4'10")	1,850 (6'1")	1,680 (5'6")	2,040 (6'8")
K	Horizontal digging stroke	Stroke	1,600 (5'3")	2,008 (6'7")	1,670 (5'6")	2,020 (6'8")
		Minimum	1,380 (4'6")	1,220 (4'0")	1,430 (4'8")	1,340 (4'5")

NOTE : Dimensions marked ※ do not include the height of the shoe lug.