

SHOP MANUAL

model

HYDRAULIC EXCAVATOR

SK 100 SK 120 SK 120LC

This is the shop manual for KOBELCO hydraulic excavator. Contained is the necessary technical data concerning the maintenance and repair of this model. The manual is divided into the following four major sections; GENERAL, SYSTEMS, COMPONENTS and PROCEDURE.

*GENERAL

- | | |
|--|---|
| LP01. SPECIFICATION | LP05. TROUBLE SHOOTING |
| LP02. OPERATION AND CONTROLS | LP06. PREVENTIVE MAINTENANCE
(Refer to Operators Manual) |
| LP03. LOCATION AND WEIGHT OF COMPONENTS | LP07. WORKING STANDARD |
| LP04. MAINTENANCE STANDARD AND
TEST PROCEDURE | |

*SYSTEMS

- | | |
|------------------------|------------------------------|
| LP11. DRIVE SYSTEM | LP22. CONTROL SYSTEM |
| LP12. HYDRAULIC SYSTEM | LP23. UPPER FRAME |
| LP15. SWING SYSTEM | LP25. ELECTRICAL SYSTEM |
| LP18. TRAVEL SYSTEM | LP26. AIR-CONDITIONER SYSTEM |
| LP21. ATTACHMENTS | LP50. ENGINE |

*COMPONENTS

- | | |
|---------------------|------------------------|
| 12. HYDRAULIC PUMP | 16. SWIVEL JOINT |
| 13. CONTROL VALVE | 17. HYDRAULIC CYLINDER |
| 14. OTHER VALVES | 21. REDUCTION UNIT |
| 15. HYDRAULIC MOTOR | |

*PROCEDURE

When checking or repairing the machine we suggest that you refer to this manual carefully. We hope that reference to this manual will help to maintain a high level of working efficiency and reliability. For further details on maintenance and checks refer to the "OPERATORS MANUAL" which has been supplied with the machine.

Although all data was correct at the time of printing, due to continual design changes and improvements, some contents may not conform to the actual machine. Take special care to order parts only after confirming the validity of the parts number in the "PARTS MANUAL".

If you notice any explanatory discrepancies, after consulting one of our representatives, please update your manual according to the latest data. However, in the event of any specification changes, we will issue revised edition.

INDEX

KOBELCO

Book code No. S5LP0005E②

WARNING

SAFETY

WARNING

The proper and safe lubrication and maintenance for this machine, recommended by KOBELCO are outlined in the OPERATION & MAINTENANCE GUIDE for this machine.

Improper performance of lubrication or maintenance procedures is dangerous and could result in injury or death. Read and understand the OPERATION & MAINTENANCE GUIDE before performing any lubrication or maintenance.

The serviceman or mechanic may be unfamiliar with many of the systems on this machine. This makes it important to use caution when performing service work. A knowledge of the system and or components is important before the removal or disassembly of any component.

Because of the size of some of the machine components, the serviceman or mechanic should check the weights noted in this Manual. Use proper lifting procedures when removing any components.

Following is a list of basic precautions that should always be observed.

1. Read and understand all Warning plates and decals on the machine before operating, lubricating or repairing this product.
2. Always wear protective glasses and protective shoes when working around machines. In particular, wear protective glasses when pounding on any part of the machine or its attachments with a hammer or sledge. Use welders gloves, hood/goggles, apron and other protective clothing appropriate to the welding job being performed. Do not wear loose-fitting or torn clothing. Remove all rings from fingers when working on machinery.
3. Disconnect battery and discharge any capacitors before starting to work on machine. Hang "Do Not Operate" tag in the Operator's Compartment.
4. If possible, make all repairs with the machine parked on a level, hard surface. Block machine so it does not roll while working on or under machine.
5. Do not work on any machine that is supported only by lift jacks or a hoist. Always use blocks or jack stands to support the machine before performing any disassembly.

WARNING

Do not operate this machine unless you have read and understand the instructions in the OPERATOR'S MANUAL. Improper machine operation is dangerous and could result in injury or death.

6. Relieve all pressure in air, oil or water systems before any lines, fittings or related items are disconnected or removed. Always make sure all raised components are blocked correctly and be alert for possible pressure when disconnecting any device from a system that utilizes pressure.
7. Lower the bucket, blade, ripper or other implements to the ground before performing any work on the machine. If this cannot be done, make sure the bucket, blade, ripper or other implement is blocked correctly to prevent it from dropping unexpectedly.
8. Use steps and grab handles when mounting or dismounting a machine. Clean any mud or debris from steps, walkways or work platforms before using. Always face machine when using steps, ladders and walkways. When it is not possible to use the designed access system, provide ladders, scaffolds, or work platforms to perform safe repair operations.
9. To avoid back injury, use a hoist when lifting components which weigh 23 kg (50 lbs) or more. Make sure all chains, hooks, slings, etc., are in good condition and are in the correct capacity. Be sure hooks are positioned correctly. Lifting eyes are not to be side loaded during a lifting operation.
10. To avoid burns, be alert for hot parts on machines which have just been stopped and hot fluids in lines, tubes and compartments.
11. Be careful when removing cover plates. Gradually back off the last two bolts or nuts located at opposite ends of the cover or device and pry cover loose to relieve any spring or other pressure, before removing the last two bolts or nuts completely.
12. Be careful when removing filler caps, breathers and plugs on the machine. Hold a rag over the cap or plug to prevent being sprayed or splashed by liquids under pressure. The danger is even greater if the machine has just been stopped because fluids can be hot.

 **WARNING**

13. Always use tools that are in good condition and be sure you understand how to use them before performing any service work.
 14. Reinstall all fasteners with same part number. Do not use a lesser quality fastener if replacements are necessary.
 15. Repairs which require welding should be performed only with the benefit of the appropriate reference information and by personnel adequately trained and knowledgeable in welding procedures. Make reference to "Techniques of Structural Repair Course". Determine type of metal being welded and select correct welding procedure and electrodes, rods or wire to provide a weld metal strength equivalent at least to that of parent metal.
 16. Do not damage wiring during removal operations. Reinstall the wiring so it is not damaged nor will it be damaged in operation by contacting sharp corners, or by rubbing against some object or hot surface. Do not connect wiring to a line containing fluid.
 17. Be sure all protective devices including guards and shields are properly installed and functioning correctly before starting a repair. If a guard or shield must be removed to perform the repair work, use extra caution.
 18. Always use lift arm supports to keep bucket arms raised and bucket tilted down when maintenance or repair work is performed which requires the bucket in the raised position.
 19. Loose or damaged fuel, lubricant and hydraulic lines, tubes and hoses can cause fires. Do not bend or strike high pressure lines or install ones which have been bent or damaged. Inspect lines, tubes and hoses carefully. Do not check for leaks with your hands. Pin hole (very small) leaks can result in a high velocity oil stream that will be invisible close to the hose. This oil can penetrate the skin and cause personal injury. Use cardboard or paper to locate pin hole leaks.
 20. Tighten connections to the correct torque. Make sure that all heat shields, clamps and guards are installed correctly to avoid excessive heat, vibration or rubbing against other parts during operation. Shields that protect against oil spray onto hot exhaust components in event of a line, tube or seal failure must be installed correctly.
 21. Do not operate a machine if any rotating part is damaged or contacts any other part during operation. Any high speed rotating component that has been damaged or altered should be checked for balance before reusing.
 22. On track-type machines, be careful when servicing or separating tracks. Chips can fly when removing or installing a track pin. Wear safety glasses. Track can unroll very quickly when separated. Keep away from front and rear of machine. The machine can move unexpectedly when both tracks are disengaged from the sprockets. Block the machine to prevent it from moving.
 23. Caution should be used to avoid breathing dust that may be generated when handling components containing asbestos fibers. If this dust is inhaled, it can be hazardous to your health. Components in Caterpillar products that may contain asbestos fibers are brake pads, brake band and lining assemblies, clutch plates and some gaskets. The asbestos used in these components is usually bound in a resin or sealed in some way. Normal handling is not hazardous as long as airborne dust which contains asbestos is not generated.
- If dust which may contain asbestos is present, there are several common sense guidelines that should be followed.
- a. Never use compressed air for cleaning.
 - b. Avoid brushing or grinding of asbestos containing materials.
 - c. For clean up, use wet methods or a vacuum equipped with a high efficiency particulate air (HEPA) filter.
 - d. Use exhaust ventilation on permanent machining jobs.
 - e. Wear an approved respirator if there is no other way to control the dust.
 - f. Comply with applicable rules and regulations for the work place.
 - g. Follow environmental rules and regulations for disposal of asbestos.
 - h. Avoid areas where asbestos particles may be in the air.

SHOP MANUAL

model

SK 100 SK 120 SK 120LC

TABLE OF CONTENTS

1. SPECIFICATION
2. OPERATION AND CONTROLS (Refer to Operators Manual)
3. LOCATION AND WEIGHT OF COMPONENTS
4. MAINTENANCE STANDARDS AND TEST PROCEDURES
5. TROUBLESHOOTING
6. PREVENTIVE MAINTENANCE (Refer to Operators Manual)
7. WORKING STANDARDS

LP01

LP03

LP04

LP05

LP07

- How to Index each Shop Manual Section
The **GENERAL** of this shop manual consists of 7 headings as shown above. Each section can be easily referred to by indexes appended to the margin of the page as indicated on the right. Please use the indexes for speedy reference.

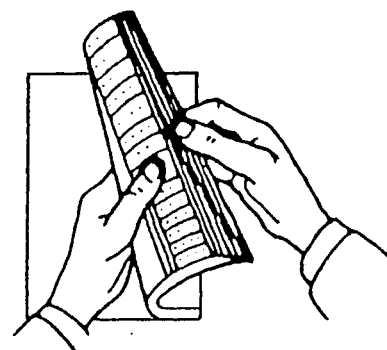

KOBELCO

GENERAL

SK100
 SK120 List of Shop Manual GENERAL Section
 SK120_{LC}

Index No.	Title	Book Code No.		
		Distribution Year - Month		
LP01	SPECIFICATION	S5LP0105E 1990-6	S5LP0105E① 1990-11	←
—	OPERATION	S2LP1011E Refer to Operators manual	←	←
LP03	LOCATION AND WEIGHT OF COMPONENTS	S5LP0304E 1990-6	←	←
LP04	MAINTENANCE STANDARDS AND TEST PROCEDURES	—	—	S5LP0406E 1991-3
LP05	TROUBLESHOOTING	S5LP0504E 1990-6	←	←
—	PREVENTIVE MAINTENANCE	S2LP1011E Refer to Operators manual	←	←
LP07	WORKING STANDARDS	S5LP0703E① 1990-6	←	←
	Applicable Machines	YW-03371~ LP-06191~ YP-01601~	←	←



Book code No. S5LP0105E①

SHOP MANUAL

SK100 SK120

LP01

SPECIFICATION

TABLE OF CONTENTS

1. NAME OF COMPONENTS	1
2. GENERAL DIMENSIONS	2
3. SPECIFICATIONS AND PERFORMANCE	5
4. TYPE OF SHOES	6
5. TYPE AND COMBINATION OF ATTACHMENTS	7
6. WORKING RANGES OF ATTACHMENTS	10
7. LIFTING-UP ABILITY DIAGRAM	15
8. ENGINE SPECIFICATIONS	22

Applicable Machines

YW-03371~

LP-06191~

Revision	Date of Issue	Remarks
First edition	March, 1990	S5LP0105E K
First revision	November, 1990	S5LP0105E① K

1. LOCATION OF COMPONENTS

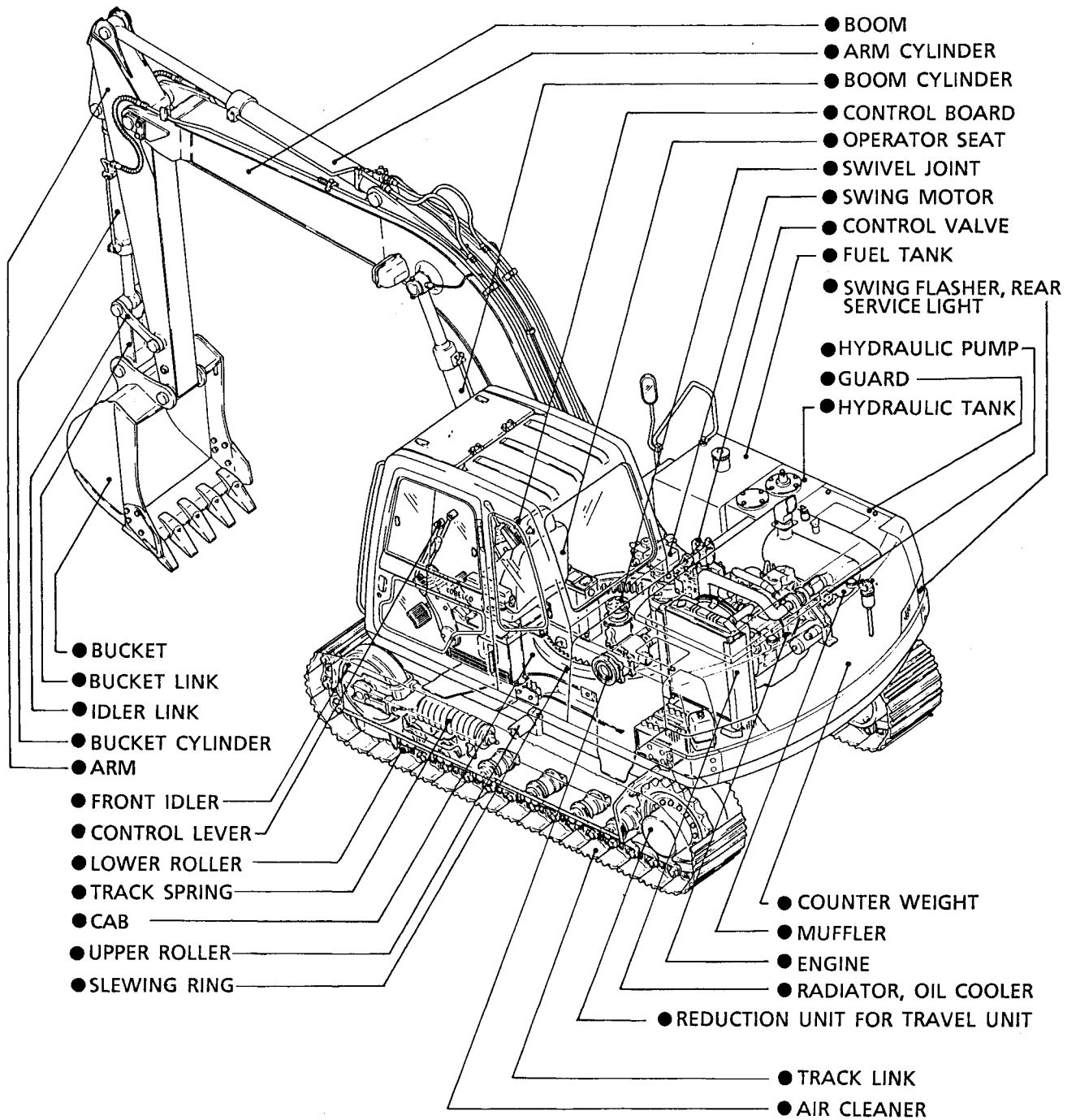

2. GENERAL DIMENSIONS

- SK100 ; 4.26m (14ft) BOOM + 2.27m (7ft 5in) ARM-ATTACHED STANDARD MACHINE
- SK120 ; 4.6m (15ft 1in) BOOM + 2.5m (8ft 2in) ARM-ATTACHED STANDARD MACHINE

Unit : mm (ft-in)

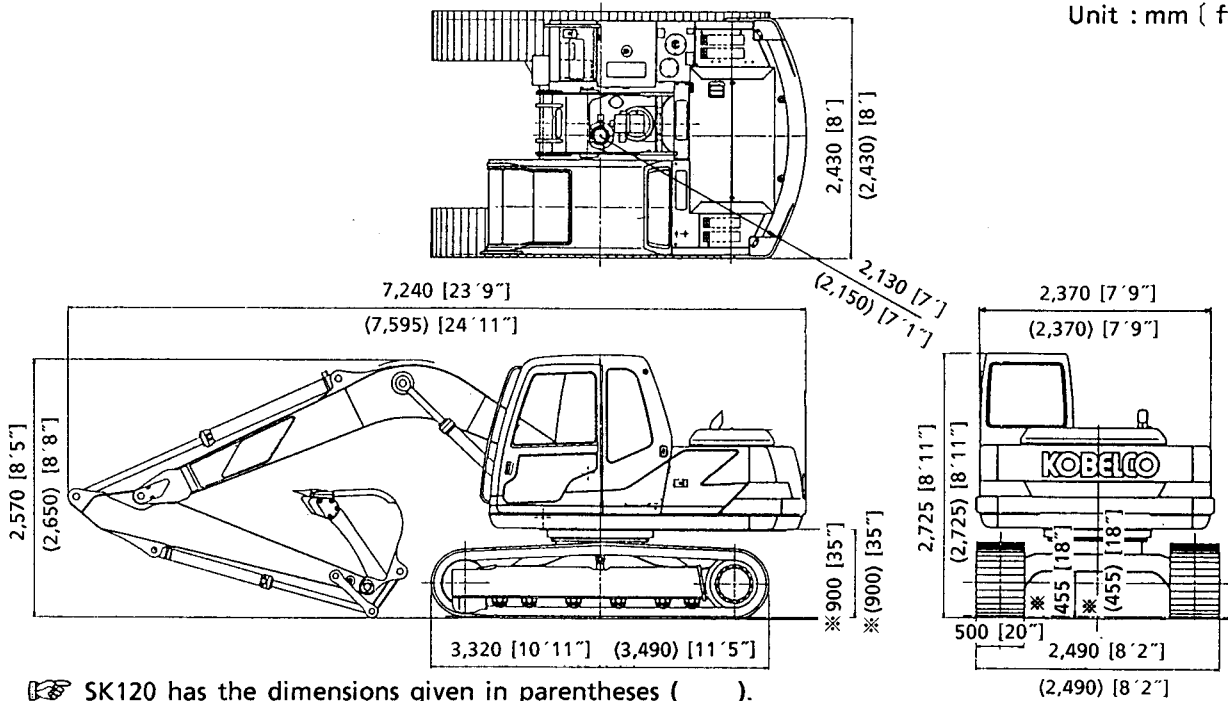

☞ SK120 has the dimensions given in parentheses ().

- SK100 ; WITH 4.26m (14ft) BOOM + 1.9m (6ft 3in) ARM
- SK120 ; WITH 4.6m (15ft 1in) BOOM + 2.1m (6ft 11in) ARM

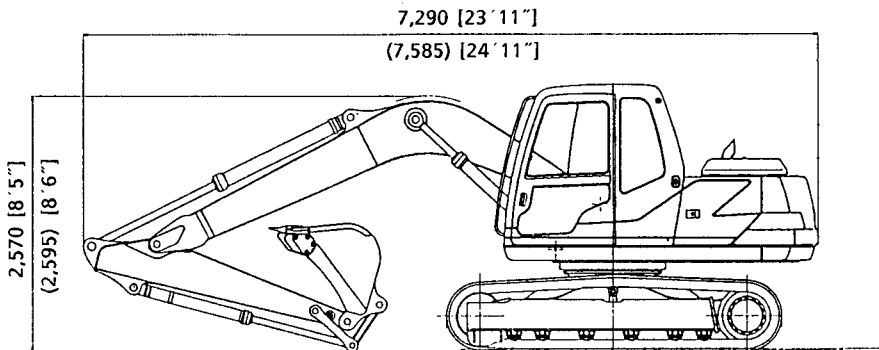

- SK100 ; WITH 4.26m (14ft) BOOM + 2.77m (9ft 1in) ARM
- SK120 ; WITH 4.6m (15ft 1in) BOOM + 3.0m (9ft 10in) ARM

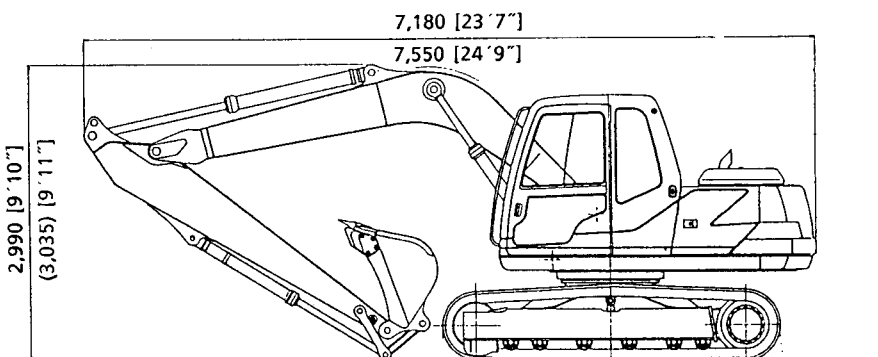

☞ The figures marked * in the illustration do not include the shoe embossment (20mm) (0.78").

- SK100 ; WITH 4.26m (14ft) BOOM + 2.27m (7ft 5in) ARM + 0.6m (2ft) EXTENSION ARM
- SK120 ; WITH 4.6m (15ft 1in) BOOM + 2.5m (8ft 2in) ARM + 1.0m (3ft 3in) EXTENSION ARM

Unit : mm [ft-in]

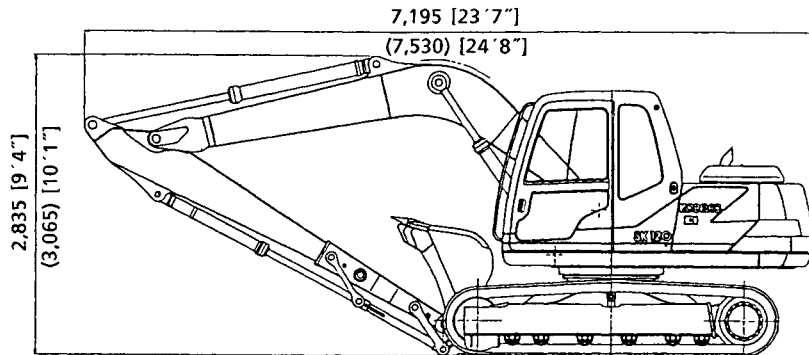

☞ SK120 has the dimensions given in parentheses ().

- SK120LC ; WITH 4.6m (15ft 1in) BOOM + 2.5m (8ft 2in) ARM-ATTACHED STAND

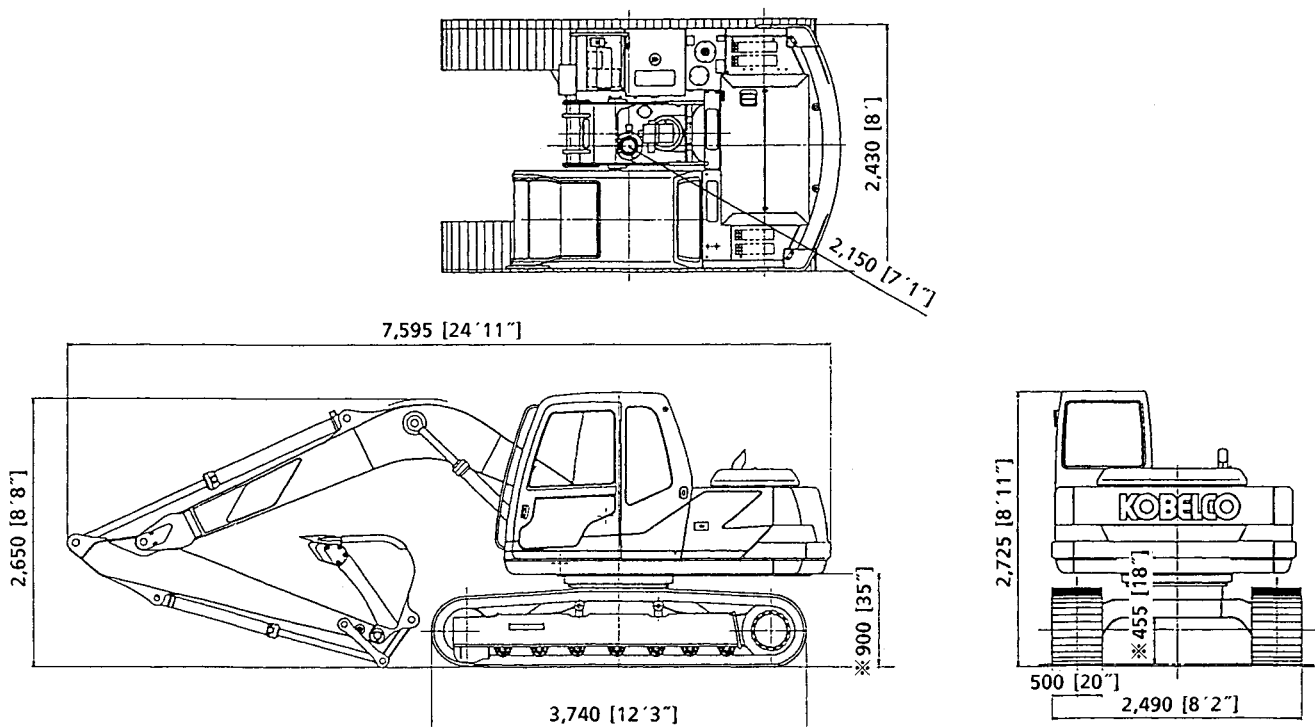

☞ The figures marked ※ in the illustration do not include the shoe embossment (20mm) (0.78").

■ SK120LC ; WITH 4.6m (15ft 1in) BOOM + 2.1m (6ft 11in) ARM

Unit : mm [ft-in]

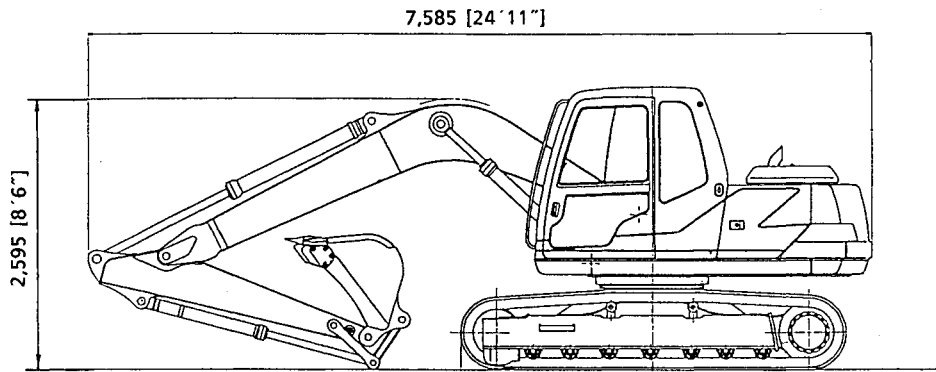

■ SK120LC ; WITH 4.6m (15ft 1in) BOOM + 3.0m (9ft 10in) ARM

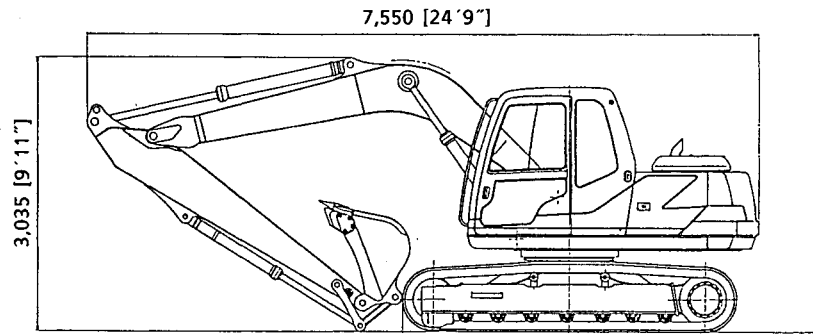

■ SK120LC ; WITH 4.6m (15ft 1in) BOOM + 2.5m (8ft 2in) ARM + 1.0m (3ft 3in) EXTENSION ARM

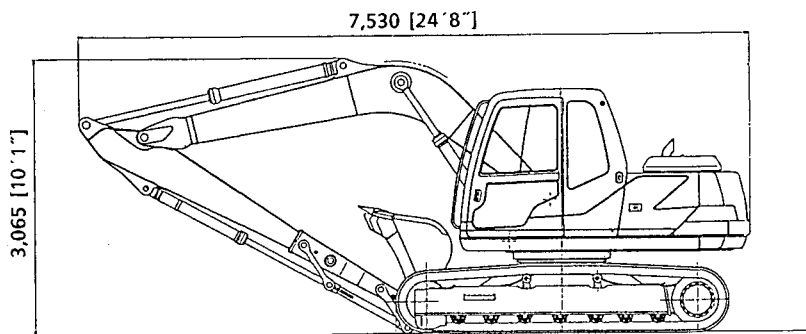

3. SPECIFICATIONS AND PERFORMANCE

■ SPEED AND CLIMBING ABILITY

Item \ Model	SK100	SK120 · SK120LC
Swing speed	12.7rpm	←
Travel speed	5.5 / 4km / h (3.4 / 2.5 MPH)	←
Gradeability	35° (70%)	←

■ ENGINE

Item \ Model	SK100	SK120 · SK120LC	
Model	ISUZU 4BD1	ISUZU 4BD1T	
Type	4-cycle, water-cooled direct injection type diesel	4-cycle, water-cooled direct injection type with turbo charger	
Number of cylinder - Bore × Stroke	4 - 102mm(4in) × 118mm(4.64in)	←	
Total displacement	3,856c.c. (235cuin)	←	
Rated output power/revolution	JISD1005 Net	76ps / 2,300rpm	85ps / 2,150rpm
	SAEJ1349 Net	54.3Kw / 2,300rpm	61.0Kw / 2,150rpm
	DIN 6270 Net	53.0Kw / 2,300rpm	59.3Kw / 2,150rpm
Maximum torque/revolution	JISD1005 Net	24kgf·m / 1,600rpm	30kgf·m / 1,600rpm
	SAEJ1349 Net	228.8N·m / 1,600rpm	287.1N·m / 1,600rpm
	DIN 6270 Net	223.4N·m / 1,600rpm	279.2K·m / 1,600rpm

■ HYDRAULIC COMPONENTS

Item \ Model	SK100	SK120 · SK120LC
Hydraulic pump	Double-pump variable displacement, axial piston + gear pump	←
Hydraulic motor (swing)	Axial piston motor	←
Hydraulic motor (travel)	Axial piston motor	←
Control valve	5-section multiple control valve + 1-section control valve (swing)	←
Cylinders (boom, arm, and bucket)	Double acting cylinder	←
Return filter	Safety valve containing filter type	←
Oil cooler	Air-cooled type	←

■ WEIGHT

Unit : kg (lbs)

Item \ Model	SK100	SK120	SK120LC
Fully-equipped weight	10,500 (23,100)	11,500 (25,400)	11,700 (25,800)
Upper machinery	4,680 (10,300)	5,430 (12,000)	←
Lower machinery (with 500mm (20") grocer shoe)	4,100 (9,000)	4,150 (9,150)	4,350 (9,590)
Attachment [4.26m (14ft) boom + 2.27m (7ft5in) arm + 0.4m ³ (0.52cuyd) bucket]	1,720 (3,800)	—	—
Attachment [4.6m (15ft1in) boom + 2.5m (8ft2in) arm + 0.45m ³ (0.59cuyd) bucket]	—	1,930 (4,250)	←

4. TYPE OF SHOES

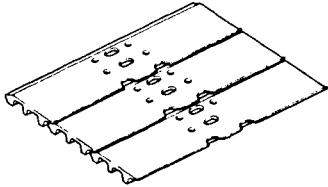
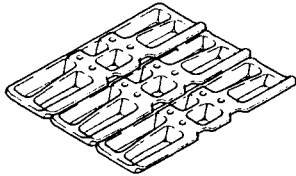
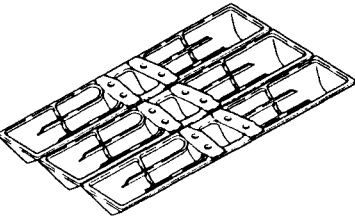
Shape	Model	Width of track shoe mm(ft-in)	Overall width of crawler mm(ft-in)	Ground contact Pressure kg/cm ² (psi)		
				STD, Arm	Short, Arm	Long, Arm
Grouser(equal height) 	SK100	500(20")	2,490(8'2")	0.36(5.12)	0.36(5.12)	0.36(5.12)
		600(24")	2,590(8'6")	0.30(4.27)	0.30(4.27)	0.31(4.41)
		41 link	700(27")	2,690(8'10")	0.26(3.70)	0.26(3.70)
	SK120	500(20")	2,490(8'2")	0.38(5.40)	0.37(5.26)	0.38(5.40)
		600(24")	2,590(8'6")	0.32(4.55)	0.32(4.55)	0.32(4.55)
		43 link	700(27")	2,690(8'10")	0.28(3.98)	0.28(3.98)
	SK120LC	500(20")	2,490(8'2")	0.36(5.12)	0.36(5.12)	0.37(5.26)
		600(24")	2,590(8'6")	0.30(4.27)	0.30(4.27)	0.30(4.27)
		46 link	700(27")	2,690(8'10")	0.26(3.70)	0.26(3.70)
Flat 	SK100	500(20")	2,490(8'2")	0.36(5.12)	0.36(5.12)	0.36(5.12)
		41 link				
	SK120	500(20")	2,490(8'2")	0.38(5.40)	0.37(5.26)	0.38(5.40)
SK120LC	43 link					
	46 link	500(20")	2,490(8'2")	0.36(5.12)	0.35(5.00)	0.36(5.12)
Triangle 	SK100	800(32")	2,790(9'2")	0.23(3.27)	0.23(3.27)	0.23(3.27)
		41 link				
	SK120	800(32")	2,790(9'2")	0.24(3.41)	0.24(3.41)	0.24(3.41)
SK120LC	43 link					
46 link	800(32")	2,790(9'2")	0.23(3.27)	0.23(3.27)	0.23(3.27)	

● 600mm (24") shoes, flat shoes and 700mm (27") triangle shoes 800 (32") come in three types, wet land, paved road and soft land. Do not use them at sites with many stones and gravels in any circumstances.

● Note that if you operate such shoe-mounted machines in general civil construction work and in a dry riverbed, it will cause shoes to bend, bring about slackening of shoe bolts and damage to under frame parts (links, crawlers, etc.).

5. TYPE AND COMBINATION OF ATTACHMENTS

■ TYPES OF BUCKETS

HOE BUCKET

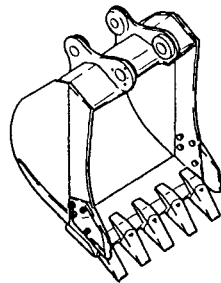

● SK100

Heaped capacity m ³ (cuyd)	Outside width of bucket mm (ft-in)		No. of teeth	Presence or not of side cutter	Possibility of turnover	Weight kg (lbs)
	With side cutter	Without side cutter				
0.15(0.20)	—	450(1' 6")	3	No	Yes	200(440)
0.25(0.33)	—	560(1' 10")	3	No	Yes	260(570)
0.3(0.39)	750(2' 5")	650(2' 2")	4	Yes	Yes	300(660)
0.35(0.46)	840(2' 9")	730(2' 5")	4	Yes	Yes	320(710)
0.4(0.52)	920(3' 0")	820(2' 8")	4	Yes	Yes	340(750)
0.45(0.59)	1,010(3' 4")	900(2' 11")	5	Yes	Yes	360(790)

● SK120,SK120LC

Heaped capacity m ³ (cuyd)	Outside width of bucket mm (ft-in)		No. of teeth	Presence or not of side cutter	Possibility of turnover	Weight kg (lbs)
	With side cutter	Without side cutter				
0.3(0.39)	730(2' 5")	630(1' 6")	4	Yes	Yes	300(660)
0.35(0.46)	820(2' 8")	720(2' 4")	4	Yes	Yes	320(710)
0.4(0.52)	900(2' 11")	800(2' 7")	4	Yes	Yes	340(750)
0.45(0.59)	980(3' 3")	880(2' 11")	5	Yes	Yes	370(820)
0.5(0.65)	1,060(3' 6")	960(3' 2")	5	Yes	Yes	380(840)
0.6(0.78)	1,230(4' 1")	1,130(3' 8")	5	No	Yes	400(880)

☞ SK120·SK120LC has the dimensions given in parentheses ().

RIPPER

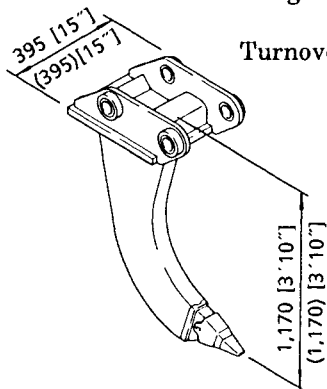

Weight : 250kg (550 lbs)
[250kg (550 lbs)]
Turnover not possible

SLOPE FINISHING BUCKET

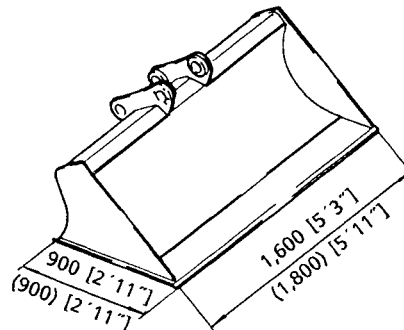

Weight : 480kg (1060 lbs)
[550kg (1210 lbs)]
Turnover not possible

SCRAPER BUCKET

Capacity: 0.45 m³ [0.59cuyd]
 (0.55m³) [0.72cuyd]
 Weight: 380kg [840 lbs]
 Turnover not possible

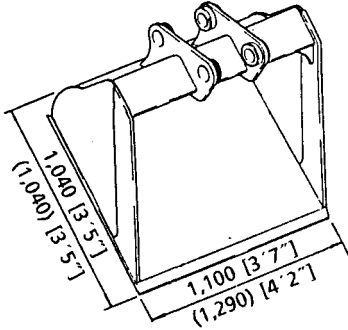

V - BUCKET

Capacity : 0.38 m³ [0.5 cuyd]
 (0.38m³) [0.5 cuyd]
 Weight : 280kg [620 lbs]
 (290kg) [640 lbs]
 Turnover not possible

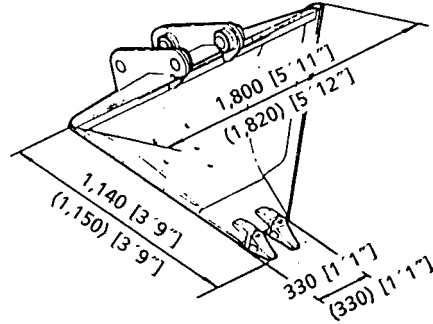

CLAMSHELL BUCKET

Capacity : 0.4 m³ [0.52cuyd]
 (0.4 m³) [0.52cuyd]
 Weight : 780kg (1,720 lbs)
 (780kg)(1,720 lbs)
 Width of opening :
 1,570mm [5ft 2in]
 (1,570mm) [5ft 2in]

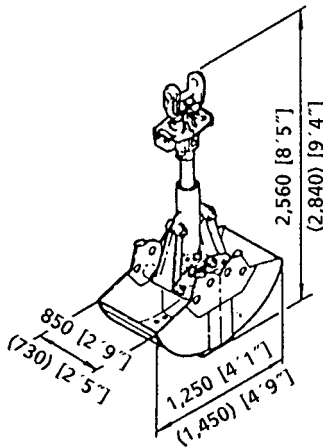

BUCKET WITH EJECTOR

Capacity: 0.2 m³ [0.26cuyd]
 (0.2m³) [0.26cuyd]
 Weight : 400kg [880 lbs]
 400kg [880 lbs]
 Turnover not possible

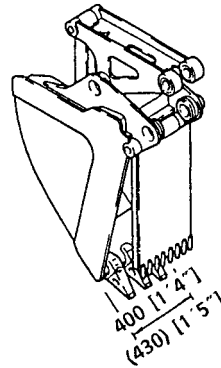

RIPPER BUCKET

Capacity: 0.3 m³ [0.39cuyd]
 (0.3m³) [0.39cuyd]
 Weight : 550kg [1,210 lbs]
 550kg [1,210 lbs]
 Turnover not possible

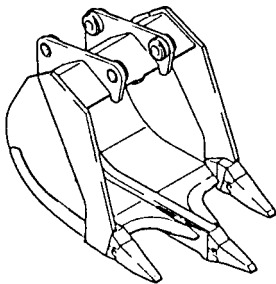

■ DIGGING FORCE

	Arm + Bucket	Digging force ton (UK ton)	
		Arm	Bucket
SK100	1.9M + 0.45m ³ (6'3" + 0.59cuyd)	6.4 (6.3)	7.5 (7.4)
	2.27M + 0.40m ³ (7'5" + 0.52cuyd)	5.6 (5.5)	↑
	2.77M + 0.35m ³ (9'1" + 0.46cuyd)	4.9 (4.8)	↑
SK120	2.1M + 0.50m ³ (6'11" + 0.65cuyd)	6.8 (6.7)	7.7 (7.6)
	2.5M + 0.45m ³ (8'2" + 0.59cuyd)	6.1 (6.0)	↑
	3.0M + 0.35m ³ (9'10" + 0.46cuyd)	5.4 (5.3)	↑

■ COMBINATIONS OF ATTACHMENTS

● SK100

Type	Bucket			Applicable arm			
	JIS heaped capacity m ³ (cuyd)	SAE heaped capacity m ³ (cuyd)	JIS-SAE struck capacity m ³ (cuyd)	1.9m (6ft3in) arm	2.27m (7ft5in) arm	2.77m (9ft1in) arm	2.27m(7ft5in) arm + 0.6m (1ft11in) extension arm
Hoe bucket	0.15 (0.20)	0.17 (0.22)	0.13 (0.17)	○	○	○	○
	0.25 (0.33)	0.28 (0.37)	0.22 (0.29)	○	○	○	○
	0.30 (0.39)	0.34 (0.44)	0.26 (0.34)	○	○	○	◎
	0.35 (0.46)	0.40 (0.52)	0.30 (0.39)	○	○	◎	△
	0.40 (0.52)	0.46 (0.60)	0.35 (0.46)	○	◎	△	×
	0.45 (0.59)	0.52 (0.68)	0.38 (0.50)	◎	△	×	×
Clamshell bucket	0.40 (0.52)	—	—	○	○	×	×
Slope finishing bucket	Width × depth 0.9m × 1.6m (2ft11in × 5ft3in)	—	—	△	△	△	△
Ripper	—	—	—	○	○	×	×
V-bucket	0.38 (0.50)	0.46 (0.60)	0.30 (0.39)	△	△	△	△
Scraper bucket	0.45 (0.59)	0.51 (0.67)	0.38 (0.50)	△	△	△	△
Bucket with ejector	0.20 (0.26)	0.22 (0.29)	0.19 (0.25)	○	○	○	○

● SK120,SK120LC

Type	Bucket			Applicable arm			
	JIS heaped capacity m ³ (cuyd)	SAE heaped capacity m ³ (cuyd)	JIS-SAE struck capacity m ³ (cuyd)	2.1m (6ft11in) arm	2.5m (8ft2in) arm	3.0m (9ft10in) arm	2.5m (8ft2in) arm + 1.0 m (3ft3in) extension arm
Hoe bucket	0.30 (0.39)	0.34 (0.44)	0.26 (0.34)	○	○	○	◎
	0.35 (0.46)	0.40 (0.52)	0.30 (0.39)	○	○	◎	△
	0.40 (0.52)	0.46 (0.60)	0.35 (0.46)	○	○	△	×
	0.45 (0.59)	0.52 (0.68)	0.38 (0.50)	○	◎	×	×
	0.50 (0.65)	0.58 (0.76)	0.42 (0.55)	◎	△	×	×
	0.60 (0.78)	0.70 (0.91)	0.52 (0.68)	△	×	×	×
Clamshell bucket	0.40 (0.52)	—	—	○	○	×	×
Slope finishing bucket	Width × depth 0.9m × 1.8m (2ft11in × 5ft11in)	—	—	△	△	△	△
Ripper	—	—	—	○	○	×	×
V-bucket	0.38 (0.50)	0.46 (0.60)	0.30 (0.39)	△	△	△	△
Scraper bucket	0.55 (0.72)	0.65 (0.85)	0.42 (0.55)	△	△	△	△
Bucket with ejector	0.20 (0.26)	0.22 (0.29)	0.19 (0.25)	○	○	○	○

☞ ◎ Standard combinations

○ General operation: Digging and loading of sand, gravels and clay-mixed soil

△ Light operation: Operations mainly consisting of loading of loose sand and soil
(for instance, operations in paddy fields and loading of sand and gravels)

× Not usable: Do not operate in such combinations as guarantee does not cover them.

⚠ ● If a bucket other than hoe buckets is used to execute turnover operation, it will cause damage to the arm and the bucket.

● The combinations other than those mentioned in the above table can not be used in principle. For details, contact us.

6. WORKING RANGES OF ATTACHMENTS

■ BACKHOE ATTACHMENT

SK100

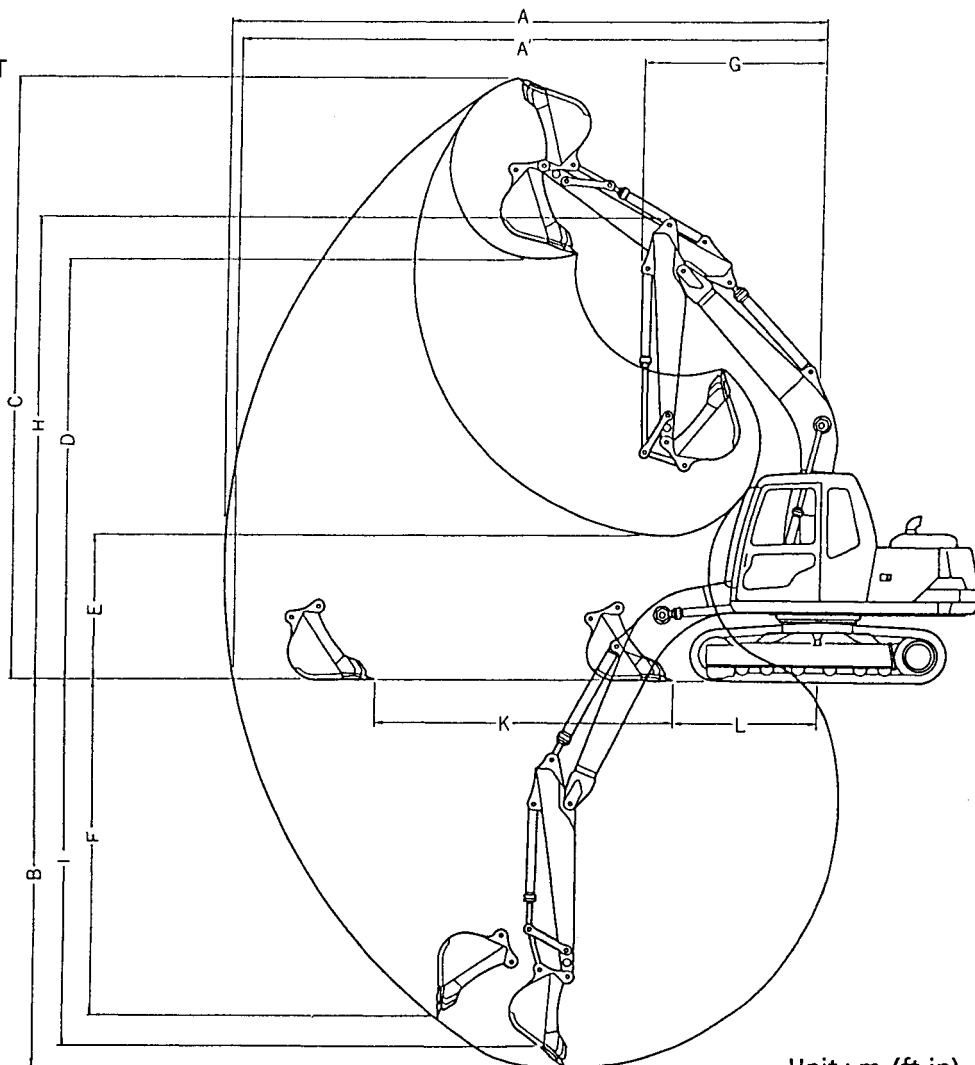

Unit ; m (ft-in)

Item	Range	Type of attachment				
		1.9m (6ft3in) arm with 0.45m ³ (0.59cuyd) bucket	2.27m (7ft5in) arm with 0.4m ³ (0.52cuyd) bucket	2.77m (9ft1in) arm with 0.35m ³ (0.46cuyd) bucket	2.27m (7ft5in) arm + 0.6m (1ft11in) arm extension arm with 0.3m ³ (0.39cuyd) bucket	
A	Max digging reach	7.38(24'3")	7.70(25'3")	8.20(26'11")	8.26(27'1")	
A'	Max. reach at ground level	7.24(23'9")	7.56(24'10")	8.07(26'6")	8.13(26'8")	
B	Max. digging depth	4.71(15'5")	5.08(16'8")	5.58(18'4")	5.68(18'8")	
C	Max. digging height	7.70(25'3")	7.86(25'9")	8.22(26'12")	8.18(26'10")	
D	Max. dumping clearance	5.33(17'6")	5.49(18')	5.85(19'2")	5.83(19'2")	
E	Min. dumping clearance	2.28(7'6")	1.88(6'2")	1.40(4'7")	1.28(4'2")	
F	Vertical digging depth	4.07(13'4")	4.41(14'6")	4.90(16'1")	4.89(16'1")	
G	Min. swing radius	2.53(8'4")	2.35(7'9")	2.49(8'2")	2.37(7'9")	
H	Height at min. swing radius	6.06(19'11")	6.03(19'9")	6.04(19'10")	6.03(19'9")	
J	Digging height at 8-flat floor	4.42(14'6")	4.81(15'9")	5.37(17'7")	5.46(17'11")	
K	Horizontal digging distance	Stroke	3.14(10'4")	3.87(12'8")	4.55(14'11")	4.78(15'8")
		At min.	2.27(7'5")	1.86(6'1")	1.68(5'6")	1.51(4'11")

⚠ The figures in this table do not include the projection of shoes (20mm (0.78in)).

■ BACKHOE ATTACHMENT

SK120,SK120Lc

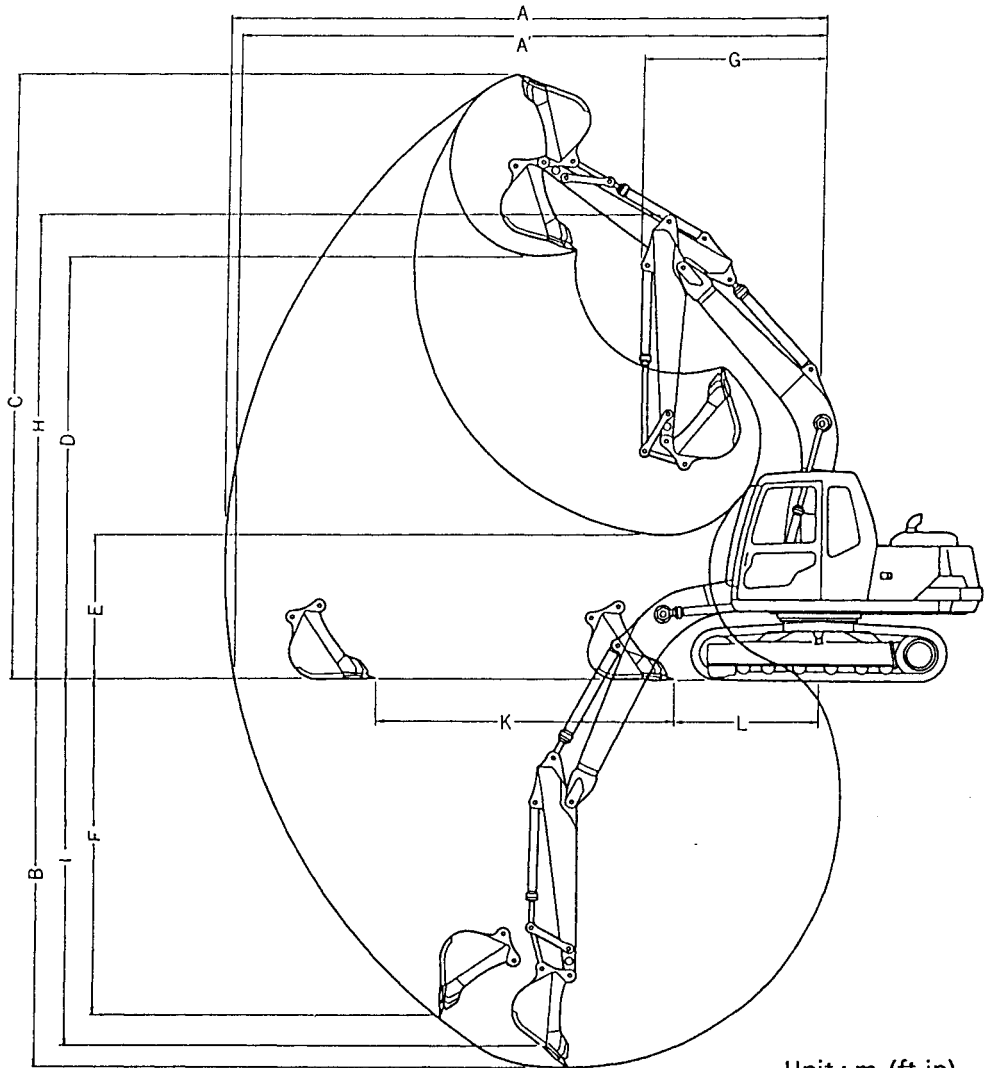

Unit ; m (ft-in)

Item		Range	Type of attachment			
			2.1m (6ft11in) arm with 0.5m ³ (0.65cuyd) bucket	2.5m (8ft2in) arm with 0.45m ³ (0.59cuyd) bucket	3.0m (9ft10in) arm with 0.35m ³ (0.46cuyd) bucket	2.5m (8ft2in) arm + 1.0m (3ft3in) arm extension arm with 0.3m ³ (0.39cuyd) bucket
A	Max digging reach		7.90(25'11")	8.25(27'1")	8.74(28'8")	9.19(30'2")
A'	Max. reach at ground level		7.75(25'5")	8.12(26'8")	8.61(28'3")	9.07(29'9")
B	Max. digging depth		5.17(16'12")	5.57(18'3")	6.07(19'11")	6.56(21'6")
C	Max. digging height		8.29(27'2")	8.50(27'11")	8.84(29')	9.08(29'9")
D	Max. dumping clearance		5.85(19'2")	6.06(19'11")	6.40(20'12")	6.64(21'9")
E	Min. dumping clearance		2.41(7'11")	2.00(6'7")	1.53(5')	1.00(3'3")
F	Vertical digging depth		4.48(14'8")	4.87(15'12")	5.33(17'6")	5.83(19'2")
G	Min. swing radius		2.39(7'10")	2.39(7'10")	2.53(8'4")	2.39(7'10")
H	Height at min. swing radius		6.46(21'2")	6.46(21'2")	6.50(21'4")	6.46(21'2")
J	Digging height at 8-flat floor		4.92(16'2")	5.35(17'7")	5.89(19'4")	6.40(21')
K	Horizontal	Stroke	3.66(12')	4.36(14'4")	4.92(16'2")	5.88(19'3")
		At min.	2.23(7'4")	1.89(6'2")	1.81(5'11")	1.30(4'3")
L	digging distance		2.23(7'4")	1.89(6'2")	1.81(5'11")	1.30(4'3")

☞ The figures in this table do not include the projection of shoes (20mm (0.78in)).

■ FACE SHOVEL ATTACHMENT

SK100

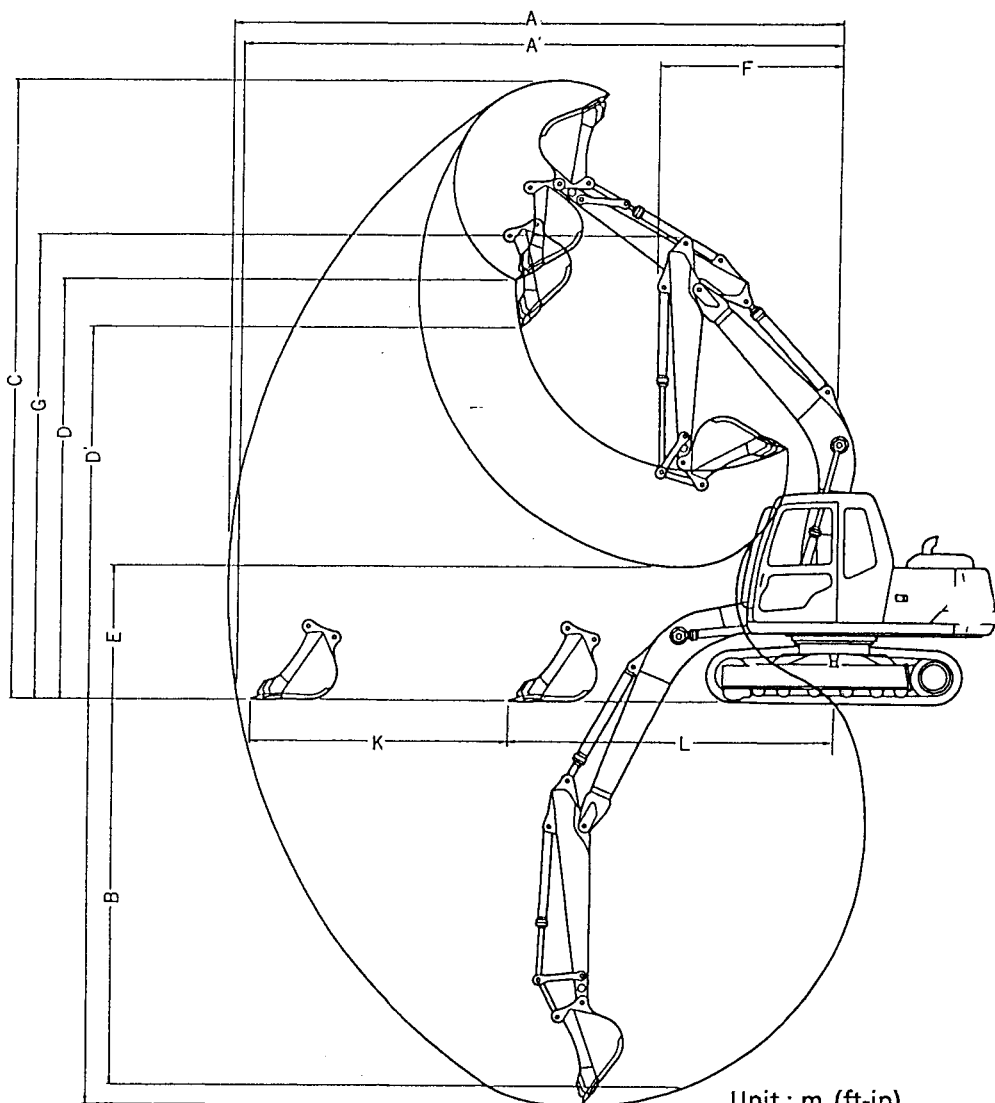

Unit ; m (ft-in)

Item	Range	Type of attachment	1.9m (6ft3in)	2.27m (7ft5in)	2.77m (9ft1in)	2.27m (7ft5in)
			arm with 0.45m ³ (0.59cuyd) bucket	arm with 0.4m ³ (0.52cuyd) bucket	arm with 0.35m ³ (0.46cuyd) bucket	arm + 0.6m (1ft11in) arm extension arm with 0.3m ³ (0.39cuyd) bucket
A	Max digging reach		7.53(24'8")	7.85(25'9")	8.34(27'4")	8.40(27'7")
A'	Max. reach at ground level		7.39(24'3")	7.71(25'3")	8.22(27')	8.28(27'2")
B	Max. digging depth		4.86(15'11")	5.23(17'2")	5.73(18'10")	5.83(19'1")
C	Max. digging height		7.90(25'11")	8.06(26'5")	8.42(27'7")	8.39(27'6")
D	Max. dumping clearance		5.30(17'5")	5.46(17'11")	5.81(19'1")	5.77(18'11")
D'	Max. dumping clearance (45°)		4.75(15'7")	4.83(15'10")	5.14(16'10")	5.15(16'11")
E	Min. dumping clearance		2.13(6'12")	1.74(5'9")	1.25(4'1")	1.14(3'9")
F	Min.swing radius		2.53(8'4")	2.35(7'9")	2.49(8'2")	2.37(7'9")
G	Height at min. swing radius		6.06(19'11")	6.03(19'9")	6.04(19'10")	6.03(19'9")
J	Digging height at 8-foot floor		4.58(15')	4.97(16'4")	5.53(18'2")	5.62(18'5")
K	Horizontal digging distance	Stroke	2.71(8'11")	3.35(10'12")	4.22(13'10")	4.38(14'4")
		At min.	4.52(14'10")	4.20(13'9")	3.82(12'6")	3.72(12'2")

☞ The figures in this table do not include the projection of shoes [20mm (0.78in)] .