

HYDRAULIC EXCAVATOR

SHOP MANUAL

model

SK100

This is the shop manual for KOBELCO hydraulic excavator. Contained is the necessary technical data concerning the maintenance and repair of this model. The manual is divided into the following four major sections; GENERAL, SYSTEMS, COMPONENTS and PROCEDURE.

*GENERAL

- | | |
|--|---|
| YW01. SPECIFICATION
— OPERATION AND CONTROLS | YW05. TROUBLE SHOOTING
— PREVENTIVE MAINTENANCE
(Refer to Operators Manual) |
| YW03. LOCATION AND WEIGHT OF COMPONENTS | YW07. WORKING STANDARD |
| YW04. MAINTENANCE STANDARD AND
TEST PROCEDURE | |

*SYSTEMS

- | | |
|------------------------|------------------------------|
| YW11. DRIVE SYSTEM | YW22. CONTROL SYSTEM |
| YW12. HYDRAULIC SYSTEM | YW23. UPPER FRAME |
| YW15. SWING SYSTEM | YW25. ELECTRICAL SYSTEM |
| YW18. TRAVEL SYSTEM | YW26. AIR-CONDITIONER SYSTEM |
| YW21. ATTACHMENTS | YW50. ENGINE |

*COMPONENTS

- | | |
|---------------------|------------------------|
| 12. HYDRAULIC PUMP | 16. SWIVEL JOINT |
| 13. CONTROL VALVE | 17. HYDRAULIC CYLINDER |
| 14. OTHER VALVES | 21. REDUCTION UNIT |
| 15. HYDRAULIC MOTOR | |

*PROCEDURE

When checking or repairing the machine we suggest that you refer to this manual carefully. We hope that reference to this manual will help to maintain a high level of working efficiency and reliability. For further details on maintenance and checks refer to the "OPERATORS MANUAL" which has been supplied with the machine.

Although all data was correct at the time of printing, due to continual design changes and improvements, some contents may not conform to the actual machine. Take special care to order parts only after confirming the validity of the parts number in the "PARTS MANUAL".

If you notice any explanatory discrepancies, after consulting one of our representatives, please update your manual according to the latest data. However, in the event of any specification changes, we will issue revised edition.

INDEX

KOBELCO

Book code No. S5YW0002E

WARNING

SAFETY

WARNING

The proper and safe lubrication and maintenance for this machine, recommended by KOBELCO are outlined in the OPERATION & MAINTENANCE GUIDE for this machine.

Improper performance of lubrication or maintenance procedures is dangerous and could result in injury or death. Read and understand the OPERATION & MAINTENANCE GUIDE before performing any lubrication or maintenance.

The serviceman or mechanic may be unfamiliar with many of the systems on this machine. This makes it important to use caution when performing service work. A knowledge of the system and or components is important before the removal or disassembly of any component.

Because of the size of some of the machine components, the serviceman or mechanic should check the weights noted in this Manual. Use proper lifting procedures when removing any components.

Following is a list of basic precautions that should always be observed.

1. Read and understand all Warning plates and decals on the machine before operating, lubricating or repairing this product.
2. Always wear protective glasses and protective shoes when working around machines. In particular, wear protective glasses when pounding on any part of the machine or its attachments with a hammer or sledge. Use welders gloves, hood/goggles, apron and other protective clothing appropriate to the welding job being performed. Do not wear loose-fitting or torn clothing. Remove all rings from fingers when working on machinery.
3. Disconnect battery and discharge any capacitors before starting to work on machine. Hang "Do Not Operate" tag in the Operator's Compartment.
4. If possible, make all repairs with the machine parked on a level, hard surface. Block machine so it does not roll while working on or under machine.
5. Do not work on any machine that is supported only by lift jacks or a hoist. Always use blocks or jack stands to support the machine before performing any disassembly.

WARNING

Do not operate this machine unless you have read and understand the instructions in the OPERATOR'S MANUAL. Improper machine operation is dangerous and could result in injury or death.

6. Relieve all pressure in air, oil or water systems before any lines, fittings or related items are disconnected or removed. Always make sure all raised components are blocked correctly and be alert for possible pressure when disconnecting any device from a system that utilizes pressure.
7. Lower the bucket, blade, ripper or other implements to the ground before performing any work on the machine. If this cannot be done, make sure the bucket, blade, ripper or other implement is blocked correctly to prevent it from dropping unexpectedly.
8. Use steps and grab handles when mounting or dismounting a machine. Clean any mud or debris from steps, walkways or work platforms before using. Always face machine when using steps, ladders and walkways. When it is not possible to use the designed access system, provide ladders, scaffolds, or work platforms to perform safe repair operations.
9. To avoid back injury, use a hoist when lifting components which weigh 23 kg (50 lbs) or more. Make sure all chains, hooks, slings, etc., are in good condition and are in the correct capacity. Be sure hooks are positioned correctly. Lifting eyes are not to be side loaded during a lifting operation.
10. To avoid burns, be alert for hot parts on machines which have just been stopped and hot fluids in lines, tubes and compartments.
11. Be careful when removing cover plates. Gradually back off the last two bolts or nuts located at opposite ends of the cover or device and pry cover loose to relieve any spring or other pressure, before removing the last two bolts or nuts completely.
12. Be careful when removing filler caps, breathers and plugs on the machine. Hold a rag over the cap or plug to prevent being sprayed or splashed by liquids under pressure. The danger is even greater if the machine has just been stopped because fluids can be hot.

 **WARNING**

13. Always use tools that are in good condition and be sure you understand how to use them before performing any service work.
 14. Reinstall all fasteners with same part number. Do not use a lesser quality fastener if replacements are necessary.
 15. Repairs which require welding should be performed only with the benefit of the appropriate reference information and by personnel adequately trained and knowledgeable in welding procedures. Make reference to "Techniques of Structural Repair Course". Determine type of metal being welded and select correct welding procedure and electrodes, rods or wire to provide a weld metal strength equivalent at least to that of parent metal.
 16. Do not damage wiring during removal operations. Reinstall the wiring so it is not damaged nor will it be damaged in operation by contacting sharp corners, or by rubbing against some object or hot surface. Do not connect wiring to a line containing fluid.
 17. Be sure all protective devices including guards and shields are properly installed and functioning correctly before starting a repair. If a guard or shield must be removed to perform the repair work, use extra caution.
 18. Always use lift arm supports to keep bucket arms raised and bucket tilted down when maintenance or repair work is performed which requires the bucket in the raised position.
 19. Loose or damaged fuel, lubricant and hydraulic lines, tubes and hoses can cause fires. Do not bend or strike high pressure lines or install ones which have been bent or damaged. Inspect lines, tubes and hoses carefully. Do not check for leaks with your hands. Pin hole (very small) leaks can result in a high velocity oil stream that will be invisible close to the hose. This oil can penetrate the skin and cause personal injury. Use cardboard or paper to locate pin hole leaks.
 20. Tighten connections to the correct torque. Make sure that all heat shields, clamps and guards are installed correctly to avoid excessive heat, vibration or rubbing against other parts during operation. Shields that protect against oil spray onto hot exhaust components in event of a line, tube or seal failure must be installed correctly.
 21. Do not operate a machine if any rotating part is damaged or contacts any other part during operation. Any high speed rotating component that has been damaged or altered should be checked for balance before reusing.
 22. On track-type machines, be careful when servicing or separating tracks. Chips can fly when removing or installing a track pin. Wear safety glasses. Track can unroll very quickly when separated. Keep away from front and rear of machine. The machine can move unexpectedly when both tracks are disengaged from the sprockets. Block the machine to prevent it from moving.
 23. Caution should be used to avoid breathing dust that may be generated when handling components containing asbestos fibers. If this dust is inhaled, it can be hazardous to your health. Components in Caterpillar products that may contain asbestos fibers are brake pads, brake band and lining assemblies, clutch plates and some gaskets. The asbestos used in these components is usually bound in a resin or sealed in some way. Normal handling is not hazardous as long as airborne dust which contains asbestos is not generated.
- If dust which may contain asbestos is present, there are several common sense guidelines that should be followed.
- a. Never use compressed air for cleaning.
 - b. Avoid brushing or grinding of asbestos containing materials.
 - c. For clean up, use wet methods or a vacuum equipped with a high efficiency particulate air (HEPA) filter.
 - d. Use exhaust ventilation on permanent machining jobs.
 - e. Wear an approved respirator if there is no other way to control the dust.
 - f. Comply with applicable rules and regulations for the work place.
 - g. Follow environmental rules and regulations for disposal of asbestos.
 - h. Avoid areas where asbestos particles may be in the air.

SHOP MANUAL

model **SK100**

TABLE OF CONTENTS

1. SPECIFICATION
2. OPERATION AND CONTROLS (Refer to Operators Manual)
3. LOCATION AND WEIGHT OF COMPONENTS
4. MAINTENANCE STANDARDS AND TEST PROCEDURES
5. TROUBLESHOOTING
6. PREVENTIVE MAINTENANCE (Refer to Operators Manual)
7. WORKING STANDARDS

YW01

YW03

YW04

YW05

YW07

○How to Index each Shop Manual Section

The GENERAL of this shop manual consists of 7 headings as shown above. Each section can be easily referred to by indexes appended to the margin of the page as indicated on the right. Please use the indexes for speedy reference.

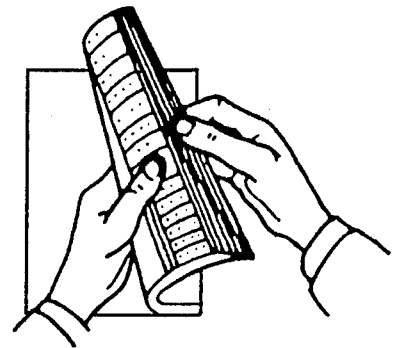

KOBELCO

GENERAL

SK100 List of Shop Manual GENERAL Section

Index No.	Title	Book Code No.		
		Distribution Year - Month		
YW01	SPECIFICATION	S5YW0102E 1990-11		
—	OPERATION	S2YW1001E Refer to Operators manual		
YW03	LOCATION AND WEIGHT OF COMPONENTS	S5YW0302E 1990-11		
YW04	MAINTENANCE STANDARDS AND TEST PROCEDURES	S5YW0402E 1990-11		
YW05	TROUBLESHOOTING	S5YW0502E 1990-11		
—	PREVENTIVE MAINTENANCE	S2YW1001E Refer to Operators manual		
YW07	WORKING STANDARDS	S5YW0702E 1990-11		
	Applicable Machines	YW-2801~		



Book code No. S5 YW01 02E

SHOP MANUAL SK100

YW01

SPECIFICATION

TABLE OF CONTENTS

1. LOCATION OF COMPONENTS	1
2. GENERAL DIMENSIONS	2
3. SPECIFICATIONS AND PERFORMANCE	4
4. TYPE OF SHOES	5
5. TYPE AND COMBINATION OF ATTACHMENTS	6
6. WORKING RANGES OF ATTACHMENTS	9
7. LIFTING-UP ABILITY DIAGRAM	12
8. ENGINE SPECIFICATIONS	14

Applicable Machines
YW-02801~

Revjision	Date of Issue	Remarks
First edition	November,1990	S5YW0102E K

1. LOCATION OF COMPONENTS

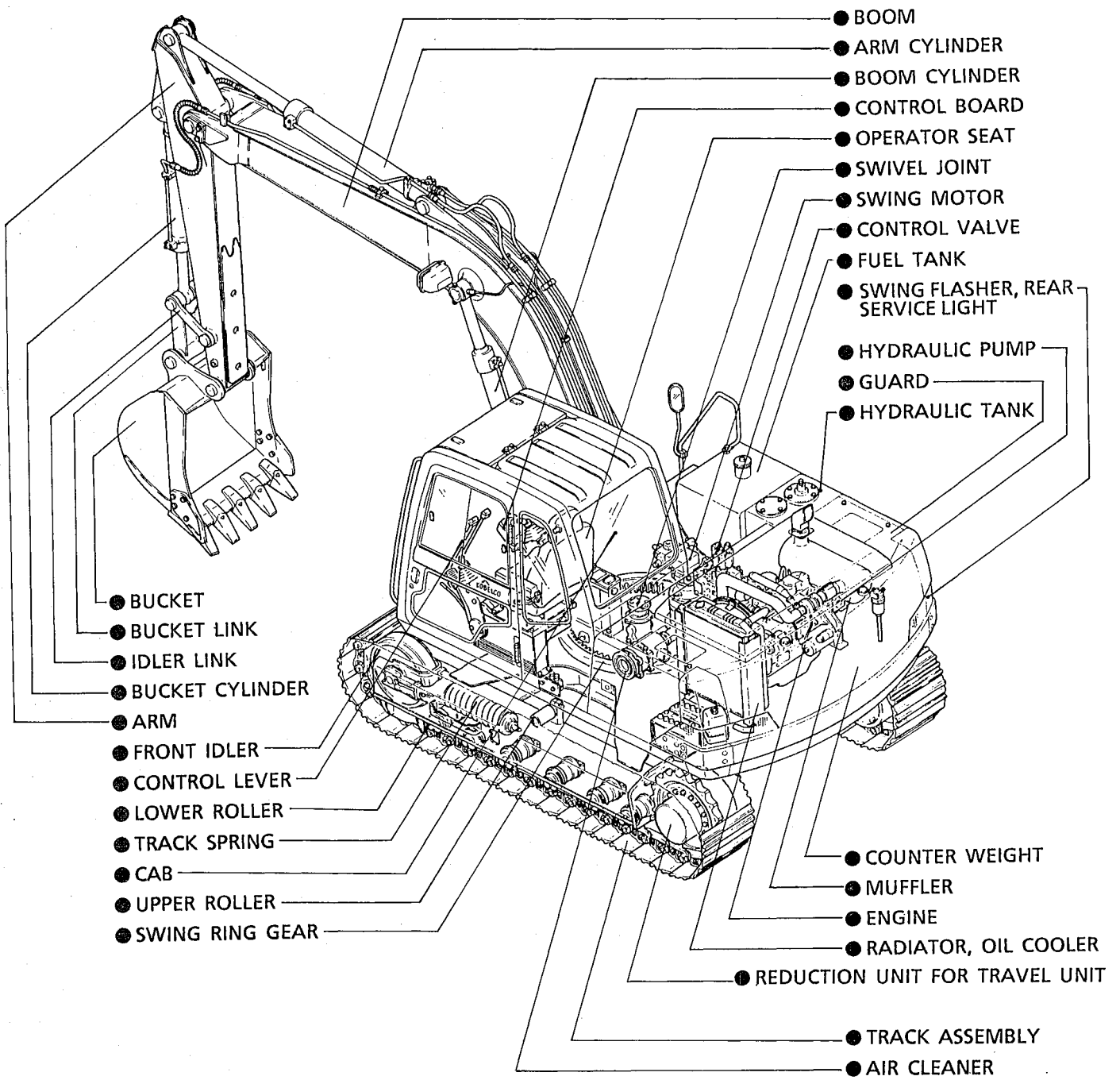

2. GENERAL DIMENSIONS

■ SK100 ; 4.26m (14ft) BOOM + 2.27m (7ft 5in) ARM-ATTACHED STANDARD MACHINE

Unit : mm (ft-in)

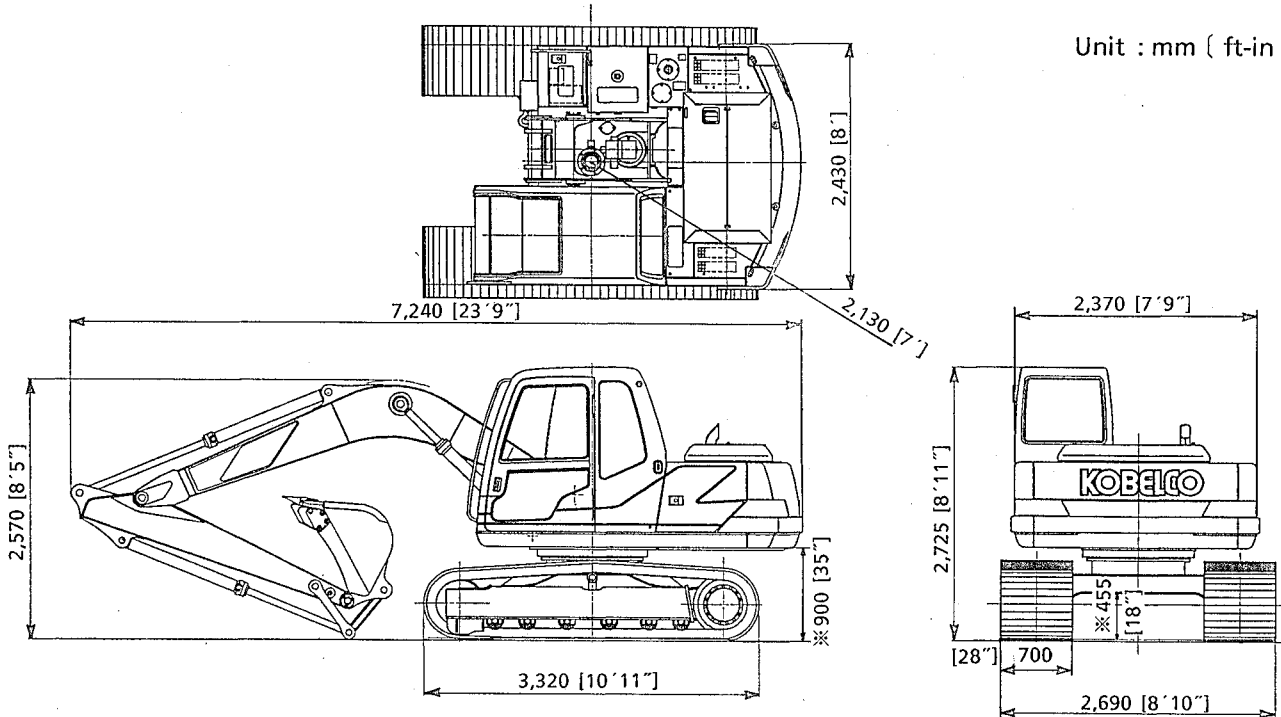

■ SK100 ; WITH 4.26m (14ft) BOOM + 1.9m (6ft 3in) ARM

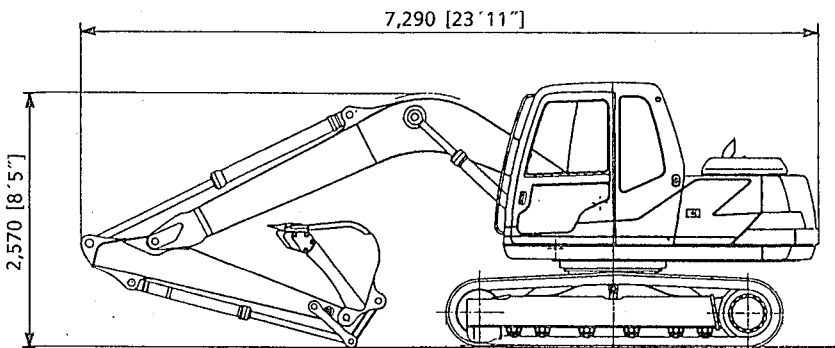

■ SK100 ; WITH 4.26m (14ft) BOOM + 2.77m (9ft 1in) ARM

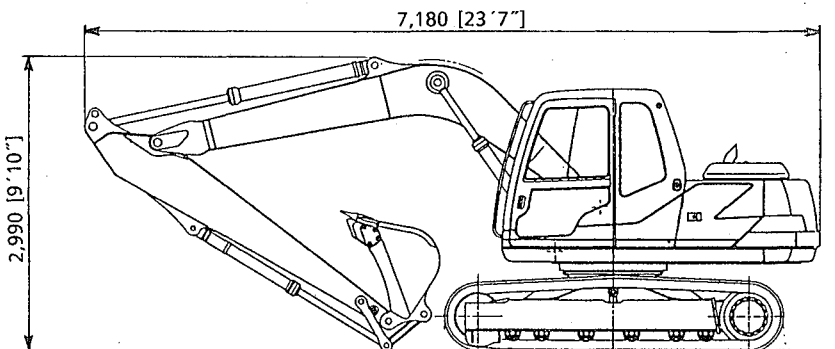

☞ The figures marked ※ in the illustration do not include the shoe embossment (20mm) (0.78").

■ SK100 ; WITH 4.26m (14ft) BOOM + 2.27m (7ft 5in) ARM + 0.6m (2ft) EXTENSION ARM

Unit : mm [ft-in]

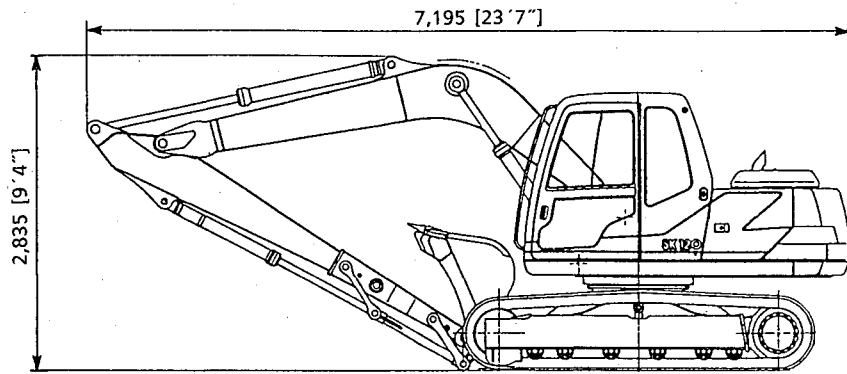

3. SPECIFICATIONS AND PERFORMANCE

■ SPEED AND CLIMBING ABILITY

Item	Model	SK100
Swing speed		12.7rpm
Travel speed		7/4km/h (4.3/2.5 MPH)
Gradeability		35° (70%)

■ ENGINE

Item	Model	SK100
Model		ISUZU 4BD1
Type		4-cycle, water-cooled direct injection type with turbo charger
Number of cylinder - Bore x Stroke		4 - 102mm(4in) x 118mm(4.64in)
Total displacement		3,856c.c. (235cuin)
Rated output power/revolution	JISD1005 Net	76ps/2,300rpm
	SAEJ1349 Net	74.9hp/2,300rpm
	DIN 6270 Net	76ps/2,300rpm
Maximum torque/revolution	JISD1005 Net	24kgf·m / 1,600rpm
	SAEJ1349 Net	173.6 lb·ft / 1,600rpm
	DIN 6270 Net	24kgf·m / 1,600rpm

■ HYDRAULIC COMPONENTS

Item	Model	SK100
Hydraulic pump		Double-pump variable displacement, axial piston + gear pump
Hydraulic motor (swing)		Axial piston motor
Hydraulic motor (travel)		Axial piston motor
Control valve		5-section multiple control valve + 1-section control valve (swing)
Cylinders (boom, arm, and bucket)		Double acting cylinder
Return filter		Safety valve containing filter type
Oil cooler		Air-cooled type

■ WEIGHT

Unit : kg (lbs)

	10,500 (23,100)	10,800 (23,800)	10,900 (24,000)
Fully-equipped weight			
Upper machinery	4,680 (10,300)	←	←
Lower machinery (with 500mm (20") grocer shoe)	4,100 (9,000)	—	—
Lower machinery (with 600mm (24") grocer shoe)	—	4,400 (9,700)	—
Lower machinery (with 700mm (28") grocer shoe)	—	—	4,500 (9,900)
Attachment [4.26m (14ft) boom + 2.27m (7ft5in) arm + 0.4m ³ (0.52cuyd) bucket]	1,720 (3,800)	←	←

4. TYPE OF SHOES

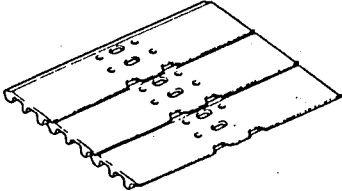
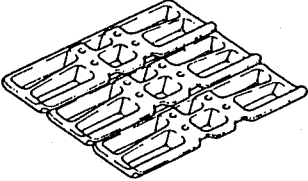
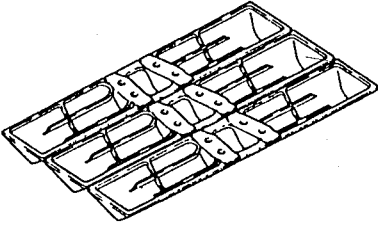
Shape	Model	Width of track shoe (mm(ft-in))	Overall width of crawler (mm(ft-in))	Ground contact pressure (kg/cm ² (psi))		
				STD, Arm	Short, Arm	Long, Arm
Grouser(equal height) 	SK100	500(20")	2,490(8'2")	0.36 (5.12)	0.36 (5.12)	0.36 (5.12)
		600(24")	2,590(8'6")	0.30 (4.27)	0.30 (4.27)	0.31 (4.41)
		700(27")	2,690(8'10")	0.26 (3.70)	0.26 (3.70)	0.26 (3.70)
	41 Link					
Flat 	SK100	500(20")	2,490(8'2")	0.36 (5.12)	0.36 (5.12)	0.36 (5.12)
		41 Link				
Triangle 	SK100	800(32")	2,790(9'2")	0.23 (3.27)	0.23 (3.27)	0.23 (3.27)
		41 Link				

☞ ● 600mm (24") shoes, flat shoes and 700mm (27") triangle shoes 800mm (32") come in three types, wet land, paved road and soft land. Do not use them at sites with many stones and gravels in any circumstances.

● Note that if you operate such shoe-mounted machines in general civil construction work and in a dry riverbed, it will cause shoes to bend, bring about slackening of shoe bolts and damage to under frame parts (links, roller, etc.).

5. TYPE AND COMBINATION OF ATTACHMENTS

■ TYPES OF BUCKETS

HOE BUCKET

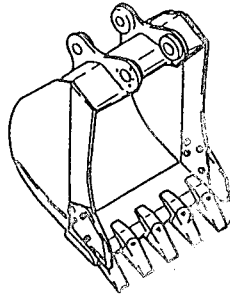

Heaped capacity m ³ (cuyd)	Outside width of bucket mm (ft-in)		No. of teeth	Presence or not of side cutter	Possibility of turnover	Weight kg (lbs)
	With side cutter	Without side cutter				
0.25(0.33)	—	560(1'10")	3	No	Yes	260(570)
0.3(0.39)	750(2'5")	650(2'2")	4	Yes	Yes	300(660)
0.35(0.46)	840(2'9")	730(2'5")	4	Yes	Yes	320(710)
0.4(0.52)	920(3'0")	820(2'8")	4	Yes	Yes	340(750)
0.45(0.59)	1,010(3'4")	900(2'11")	5	Yes	Yes	360(790)

RIPPER

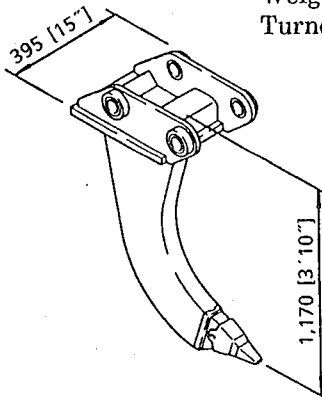

Weight : 250kg (550 lbs)
Turnover not possible

SLOPE FINISHING BUCKET

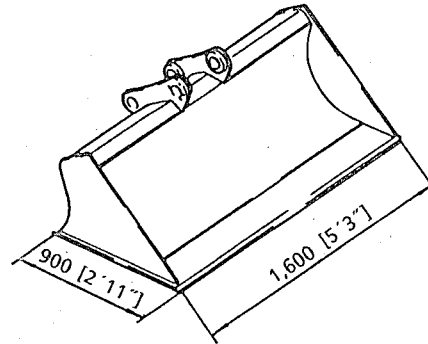

Weight : 480kg (1060 lbs)
Turnover not possible

SCRAPER BUCKET

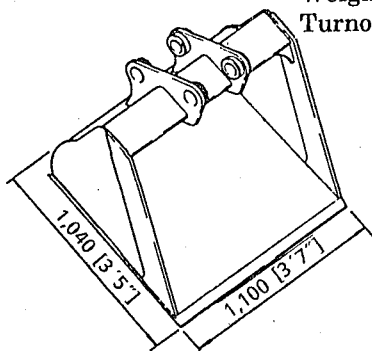

Capacity: 0.45 m³ [0.59cuyd]
Weight : 380kg [840 lbs]
Turnover not possible

V - BUCKET

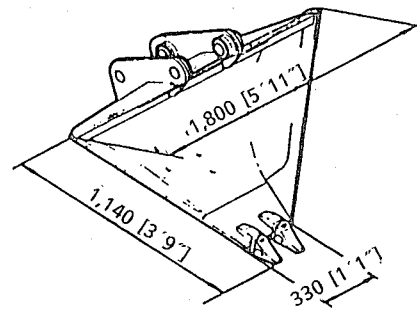

Capacity : 0.38 m³ [0.5 cuyd]
Weight : 280kg [640 lbs]
Turnover not possible

CLAMSHELL BUCKET

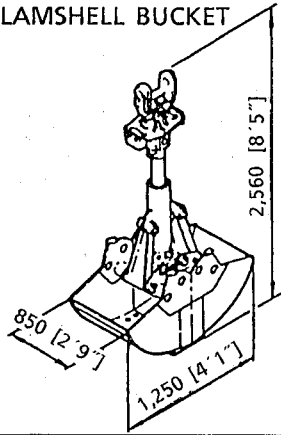

Capacity : 0.4 m³ [0.52cuyd]
Weight : 780kg (1,720 lbs)
Width of opening :
1,570mm [5ft 2in]

BUCKET WITH EJECTOR

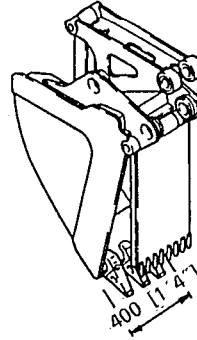

Capacity: 0.2 m³ [0.26cuyd]
Weight : 400kg (880 lbs)
Turnover not possible

RIPPER BUCKET

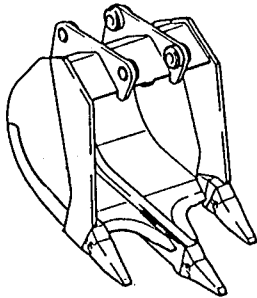

Capacity: 0.3 m³ [0.39cuyd]
Weight : 550kg (1,210 lbs)
Turnover not possible

■ COMBINATIONS OF ATTACHMENTS

Type	Bucket			Applicable arm			
	JIS heaped capacity m ³ (cuyd)	SAE heaped capacity m ³ (cuyd)	JIS/SAE struck capacity m ³ (cuyd)	1.9m (6ft3in) arm	2.27m (7ft5in) arm	2.77m (9ft1in) arm	2.27m(7ft5in) arm + 0.6m (1ft11in) extension arm
Hoe bucket	0.25 (0.33)	0.28 (0.37)	0.22 (0.29)	○	○	○	○
	0.30 (0.39)	0.34 (0.44)	0.26 (0.34)	○	○	○	⊙
	0.35 (0.46)	0.40 (0.52)	0.30 (0.39)	○	○	⊙	△
	0.40 (0.52)	0.46 (0.60)	0.35 (0.46)	○	⊙	△	×
	0.45 (0.59)	0.52 (0.68)	0.38 (0.50)	⊙	△	×	×
Clamshell bucket	0.40 (0.52)	—	—	○	○	×	×
Slope finishing bucket	Width × depth 0.9m × 1.6m (2ft11in × 5ft3in)	—	—	△	△	△	△
Ripper	—	—	—	○	○	×	×
V-bucket	0.38 (0.50)	0.46 (0.60)	0.30 (0.39)	△	△	△	△
Scraper bucket	0.45 (0.59)	0.51 (0.67)	0.38 (0.50)	△	△	△	△
Bucket with ejector	0.20 (0.26)	0.22 (0.29)	0.19 (0.25)	○	○	○	○

☞ ⊙ Standard combinations

- General operation : Digging and loading of sand, gravels and clay-mixed soil
- △ Light operation : Operations mainly consisting of loading of loose sand and soil (for instance, operations in paddy fields and loading of sand and gravels)
- × Not usable : Do not operate in such combinations as guarantee does not cover them.

⚠ ⊙ If a bucket other than hoe buckets is used to execute turnover operation, it will cause damage to the arm and the bucket.

⊙ The combinations other than those mentioned in the above table can not be used in principle. For details, contact us.

■ DIGGING FORCE

	Arm + Bucket		Digging force ton (UK ton)	
	Arm	Bucket	Arm	Bucket
SK100	1.9M + 0.45m ³	(6'3" + 0.59cuyd)	6.4 (6.3)	7.5 (7.4)
	2.27M + 0.40m ³	(7'5" + 0.52cuyd)	5.6 (5.5)	↑
	2.77M + 0.35m ³	(9'1" + 0.46cuyd)	4.9 (4.8)	↑

6. WORKING RANGES OF ATTACHMENTS

■ BACKHOE ATTACHMENT

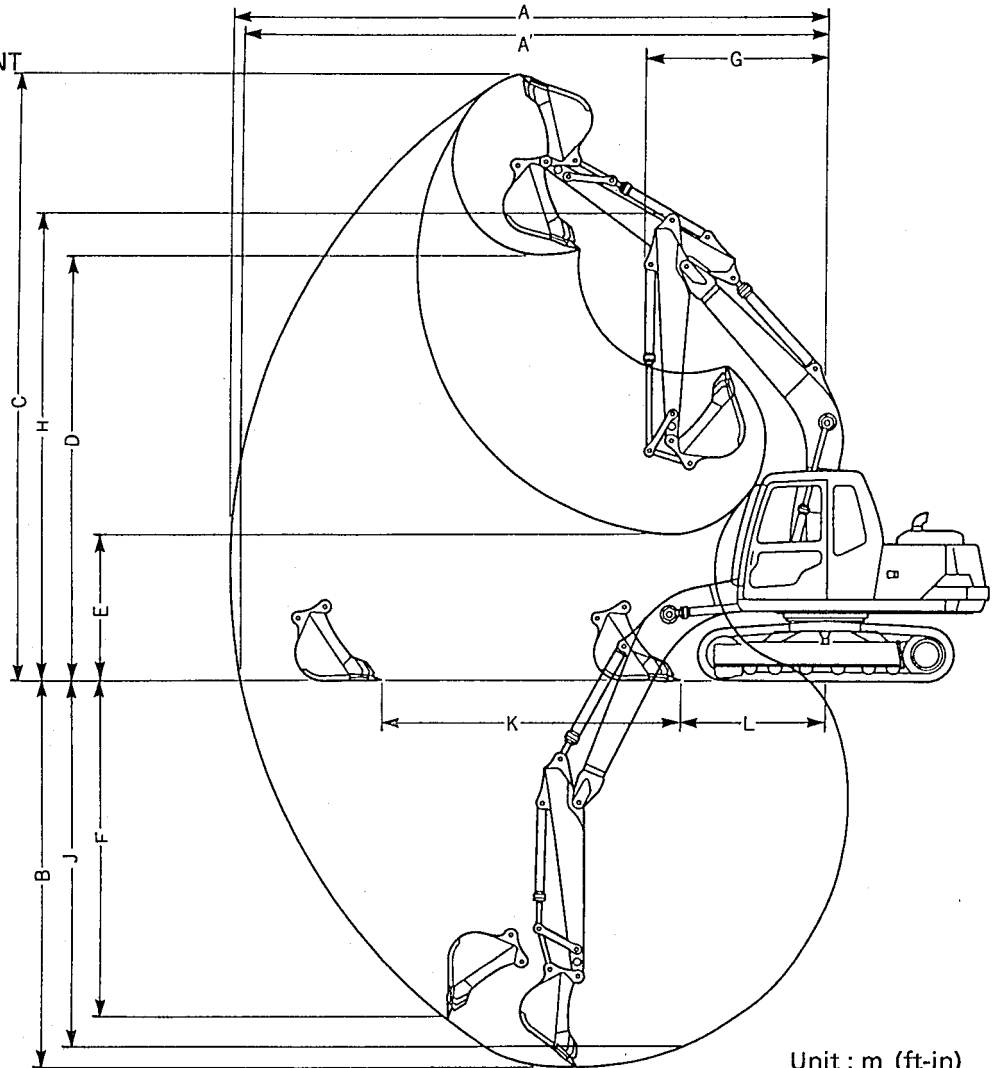

Unit ; m (ft-in)

Item		Range	Type of attachment	1.9m (6ft3in) arm with 0.45m ³ (0.59cuyd) bucket	2.27m (7ft5in) arm with 0.4m ³ (0.52cuyd) bucket	2.77m (9ft1in) arm with 0.35m ³ (0.46cuyd) bucket	2.27m (7ft5in) arm + 0.6m (1ft11in) arm extension arm with 0.3m ³ (0.39cuyd) bucket
A	Max digging reach			7.38(24'3")	7.70(25'3")	8.20(26'11")	8.26(27'1")
A'	Max. reach at ground level			7.24(23'9")	7.56(24'10")	8.07(26'6")	8.13(26'8")
B	Max. digging depth			4.71(15'5")	5.08(16'8")	5.58(18'4")	5.68(18'8")
C	Max. digging height			7.70(25'3")	7.86(25'9")	8.22(26'12")	8.18(26'10")
D	Max. dumping clearance			5.33(17'6")	5.49(18')	5.85(19'2")	5.83(19'2")
E	Min. dumping clearance			2.28(7'6")	1.88(6'2")	1.40(4'7")	1.28(4'2")
F	Max. vertical digging depth			4.07(13'4")	4.41(14'6")	4.90(16'1")	4.89(16'1")
G	Min. swing radius			2.53(8'4")	2.35(7'9")	2.49(8'2")	2.37(7'9")
H	Height at min. swing radius			6.06(19'11")	6.03(19'9")	6.04(19'10")	6.03(19'9")
J	Digging depth at 8ft-flat floor			4.42(14'6")	4.81(15'9")	5.37(17'7")	5.46(17'11")
K	Horizontal	Stroke		3.14(10'4")	3.87(12'8")	4.55(14'11")	4.78(15'8")
		At min.		2.27(7'5")	1.86(6'1")	1.68(5'6")	1.51(4'11")
L	digging distance			2.27(7'5")	1.86(6'1")	1.68(5'6")	1.51(4'11")

☞ The figures in this table do not include the projection of shoes (20mm (0.78in)).

■ FACE SHOVEL ATTACHMENT

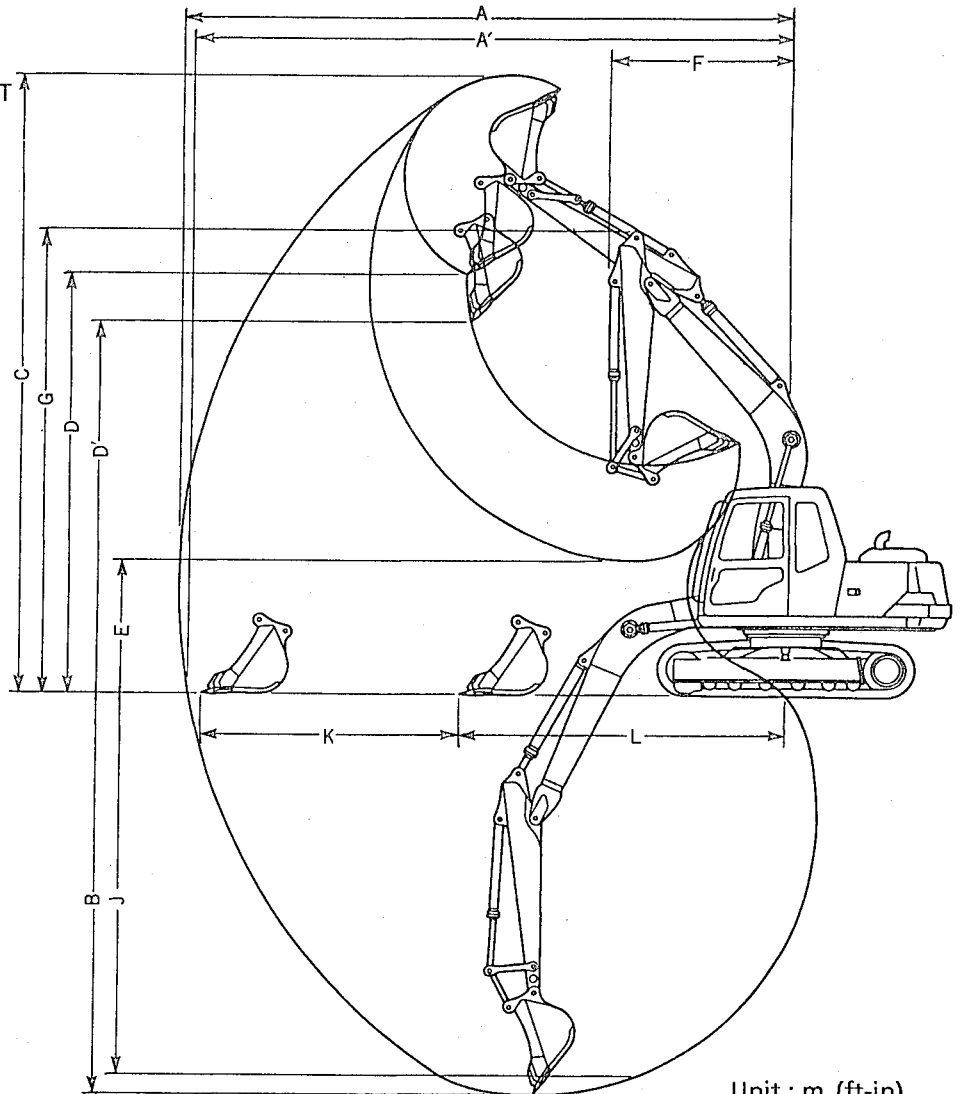

Unit ; m (ft-in)

Item	Range	Type of attachment	Type of attachment			
			1.9m (6ft3in) arm with 0.45m ³ (0.59cuyd) bucket	2.27m (7ft5in) arm with 0.4m ³ (0.52cuyd) bucket	2.77m (9ft1in) arm with 0.35m ³ (0.46cuyd) bucket	2.27m (7ft5in) arm + 0.6m (1ft11in) arm extension arm with 0.3m ³ (0.39cuyd) bucket
A	Max digging reach		7.53(24'8")	7.85(25'9")	8.34(27'4")	8.40(27'7")
A'	Max. reach at ground level		7.39(24'3")	7.71(25'3")	8.22(27')	8.28(27'2")
B	Max. digging depth		4.86(15'11")	5.23(17'2")	5.73(18'10")	5.83(19'1")
C	Max. digging height		7.90(25'11")	8.06(26'5")	8.42(27'7")	8.39(27'6")
D	Max. dumping clearance		5.30(17'5")	5.46(17'11")	5.81(19'1")	5.77(18'11")
D'	Max. dumping clearance (45°)		4.75(15'7")	4.83(15'10")	5.14(16'10")	5.15(16'11")
E	Min. dumping clearance		2.13(6'12")	1.74(5'9")	1.25(4'1")	1.14(3'9")
F	Min. swing radius		2.53(8'4")	2.35(7'9")	2.49(8'2")	2.37(7'9")
G	Height at min. swing radius		6.06(19'11")	6.03(19'9")	6.04(19'10")	6.03(19'9")
J	Digging depth at 8ft-flat floor		4.58(15')	4.97(16'4")	5.53(18'2")	5.62(18'5")
K	Horizontal digging distance	Stroke	2.71(8'11")	3.35(10'12")	4.22(13'10")	4.38(14'4")
		At min.	4.52(14'10")	4.20(13'9")	3.82(12'6")	3.72(12'2")

☞ The figures in this table do not include the projection of shoes (20mm (0.78in)).

■ CLAMSHELL ATTACHMENT

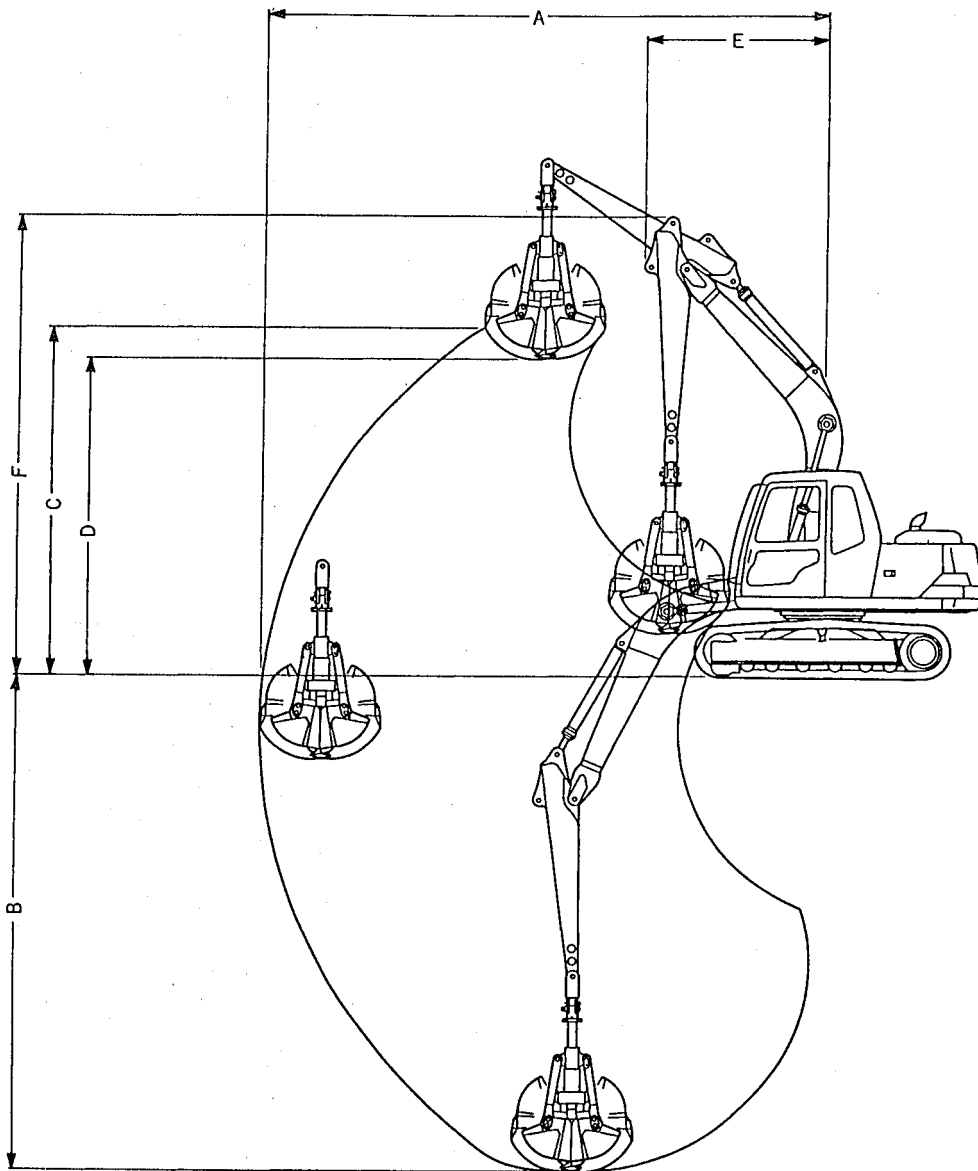

Unit ; m (ft-in)

Item	Range	Type of attachment	
		1.9m (6ft3in) arm 0.4m ³ (0.52cuyd) bucket	2.27m (7ft5in) arm 0.4m ³ (0.52cuyd) bucket
A	Max digging reach	6.96(22'10")	7.27(23'10")
B	Max. digging depth	6.02(19'9")	6.39(21')
C	Max. digging height	4.43(14'6")	4.59(15'1")
D	Max. dumping clearance	4.02(13'2")	4.18(13'9")
E	Min. dumping clearance	2.33(7'8")	2.35(7'9")
F	Height at min. swing radius	6.06(19'11")	6.03(19'9")

⚠ The figures in this table do not include the projection of shoes (20mm (0.78in)).

7. LIFTING-UP ABILITY DIAGRAM

SK100 WITH 2.27m (7 ft-5 in) ARM (STD)

360° SWING (FRONT)

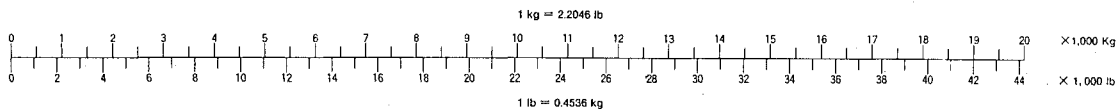

The lifting-up ability of this drawing is indicated by metric standard.

The indicated figures fall within 87% of a set pressure of the main relief valve used in the arm and the boom cylinder and 75% of static tilting load.

SPECIFICATION

- (1) The 700mm (27") shoe
- (2) S.T.D (Pressure)

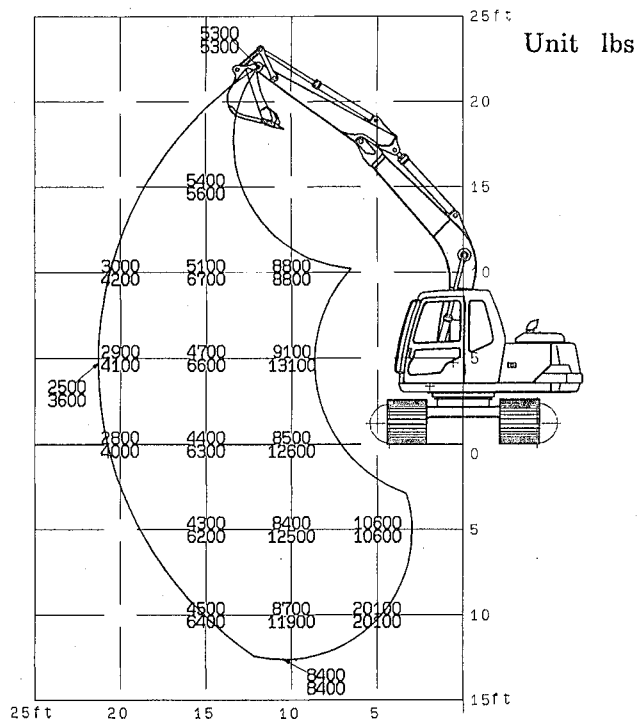

SK100 WITH 1.9m (6 ft-3 in) ARM

360° SWING (FRONT)

The lifting-up ability of this drawing is indicated by metric standard.

The indicated figures fall within 87% of a set pressure of the main relief valve used in the arm and the boom cylinder and 75% of static tilting load.

SPECIFICATION

- (1) The 700mm (27") shoe
- (2) S. T. D (Pressure)

