

Book code No.

S 5 P Y 0 0 0 2 E ①

KOBELCO

SK 045
SK 045-2
SK 050

SHOP MANUAL

 **KOBE STEEL, LTD.**

Applicable Machines

PY-02001~

PZ-00101~

Revision	Date of Issue	Remarks
First edition	April, 1992	S5PY0002E K
First revision	Oct, 1994	S5PY0002E① K

WARNING

SAFETY

WARNING

The proper and safe lubrication and maintenance for this machine, recommended by KOBELCO are outlined in the OPERATORS MANUAL for this machine.

Improper performance of lubrication or maintenance procedures is dangerous and could result in injury or death. Read and understand the OPERATORS MANUAL before performing any lubrication or maintenance.

The serviceman or mechanic may be unfamiliar with many of the systems on this machine. This makes it important to use caution when performing service work. A knowledge of the system and or components is important before the removal or disassembly of any component.

Because of the size of some of the machine components, the serviceman or mechanic should check the weights noted in this Manual. Use proper lifting procedures when removing any components.

Following is a list of basic precautions that should always be observed.

1. Read and understand all Warning plates and decals on the machine before operating, lubricating or repairing this product.
2. Always wear protective glasses and protective shoes when working around machines. In particular, wear protective glasses when pounding on any part of the machine or its attachments with a hammer or sledge. Use welders gloves, hood/goggles, apron and other protective clothing appropriate to the welding job being performed. Do not wear loose-fitting or torn clothing. Remove all rings from fingers when working on machinery.
3. Disconnect battery and discharge any capacitors before starting to work on machine. Hang "Do Not Operate" tag in the Operator's Compartment.
4. If possible, make all repairs with the machine parked on a level, hard surface. Block machine so it does not roll while working on or under machine.
5. Do not work on any machine that is supported only by lift jacks or a hoist. Always use blocks or jack stands to support the machine before performing any disassembly.

WARNING

Do not operate this machine unless you have read and understand the instructions in the OPERATORS MANUAL. Improper machine operation is dangerous and could result in injury or death.

6. Relieve all pressure in air, oil or water systems before any lines, fittings or related items are disconnected or removed. Always make sure all raised components are blocked correctly and be alert for possible pressure when disconnecting any device from a system that utilizes pressure.
7. Lower the bucket, blade, ripper or other implements to the ground before performing any work on the machine. If this cannot be done, make sure the bucket, blade, ripper or other implement is blocked correctly to prevent it from dropping unexpectedly.
8. Use steps and grab handles when mounting or dismounting a machine. Clean any mud or debris from steps, walkways or work platforms before using. Always face machine when using steps, ladders and walkways. When it is not possible to use the designed access system, provide ladders, scaffolds, or work platforms to perform safe repair operations:
9. To avoid back injury, use a hoist when lifting components which weigh 23 kg (50 lbs) or more. Make sure all chains, hooks, slings, etc., are in good condition and are in the correct capacity. Be sure hooks are positioned correctly. Lifting eyes are not to be side loaded during a lifting operation.
10. To avoid burns, be alert for hot parts on machines which have just been stopped and hot fluids in lines, tubes and compartments.
11. Be careful when removing cover plates. Gradually back off the last two bolts or nuts located at opposite ends of the cover or device and pry cover loose to relieve any spring or other pressure, before removing the last two bolts or nuts completely.
12. Be careful when removing filler caps, breathers and plugs on the machine. Hold a rag over the cap or plug to prevent being sprayed or splashed by liquids under pressure. The danger is even greater if the machine has just been stopped because fluids can be hot.

 **WARNING**

13. Always use tools that are in good condition and be sure you understand how to use them before performing any service work.
 14. Reinstall all fasteners with same part number. Do not use a lesser quality fastener if replacements are necessary.
 15. Repairs which require welding should be performed only with the benefit of the appropriate reference information and by personnel adequately trained and knowledgeable in welding procedures. Make reference to "Techniques of Structural Repair Course". Determine type of metal being welded and select correct welding procedure and electrodes, rods or wire to provide a weld metal strength equivalent at least to that of parent metal.
 16. Do not damage wiring during removal operations. Reinstall the wiring so it is not damaged nor will it be damaged in operation by contacting sharp corners, or by rubbing against some object or hot surface. Do not connect wiring to a line containing fluid.
 17. Be sure all protective devices including guards and shields are properly installed and functioning correctly before starting a repair. If a guard or shield must be removed to perform the repair work, use extra caution.
 18. Always use lift arm supports to keep bucket arms raised and bucket tilted down when maintenance or repair work is performed which requires the bucket in the raised position.
 19. Loose or damaged fuel, lubricant and hydraulic lines, tubes and hoses can cause fires. Do not bend or strike high pressure lines or install ones which have been bent or damaged. Inspect lines, tubes and hoses carefully. Do not check for leaks with your hands. Pin hole (very small) leaks can result in a high velocity oil stream that will be invisible close to the hose. This oil can penetrate the skin and cause personal injury. Use cardboard or paper to locate pin hole leaks.
 20. Tighten connections to the correct torque. Make sure that all heat shields, clamps and guards are installed correctly to avoid excessive heat, vibration or rubbing against other parts during operation. Shields that protect against oil spray onto hot exhaust components in event of a line, tube or seal failure must be installed correctly.
 21. Do not operate a machine if any rotating part is damaged or contacts any other part during operation. Any high speed rotating component that has been damaged or altered should be checked for balance before reusing.
 22. On track-type machines, be careful when servicing or separating tracks. Chips can fly when removing or installing a track pin. Wear safety glasses. Track can unroll very quickly when separated. Keep away from front and rear of machine. The machine can move unexpectedly when both tracks are disengaged from the sprockets. Block the machine to prevent it from moving.
 23. Caution should be used to avoid breathing dust that may be generated when handling components containing asbestos fibers. If this dust is inhaled, it can be hazardous to your health. Components in KOBELCO products that may contain asbestos fibers are brake pads, brake band and lining assemblies, clutch plates and some gaskets. The asbestos used in these components is usually bound in a resin or sealed in some way. Normal handling is not hazardous as long as airborne dust which contains asbestos is not generated.
- If dust which may contain asbestos is present, there are several common sense guidelines that should be followed.
- a. Never use compressed air for cleaning.
 - b. Avoid brushing or grinding of asbestos containing materials.
 - c. For clean up, use wet methods or a vacuum equipped with a high efficiency particulate air (HEPA) filter.
 - d. Use exhaust ventilation on permanent machining jobs.
 - e. Wear an approved respirator if there is no other way to control the dust.
 - f. Comply with applicable rules and regulations for the work place.
 - g. Follow environmental rules and regulations for disposal of asbestos.
 - h. Avoid areas where asbestos particles may be in the air.

INTRODUCTION

This manual is designed for those who are engaged in maintenance work. It explains procedures for disassembly, reassembly, inspection and maintenance, standard values for maintenance, diagnosis of trouble and brief specifications for each part of the machine. Use this manual as a reference guide and as a means of improving your maintenance techniques in your day to day service activities. Furthermore, please be advised that the contents of this manual are subject to change without notice due to design changes, etc.

MACHINE FRONT TO BACK, AND LEFT TO RIGHT ORIENTATION

The end where the dozer blade is mounted is called the machine's front and the end containing the travel drive equipment is called the back. The left and right sides are the left and right sides when the operator is sitting in the driver's seat.

MACHINE SERIAL NUMBER

The machine serial number is stamped on the vehicle number plate. Be sure to give this number whenever making reports concerning the machine, when making inquiries and when ordering parts, etc.

Symbols Used in this Manual

In this manual, sections of particular importance are marked with the symbols shown below.



This indicates sections containing important information on safety.



This mark indicates cautions including those concerning damage of the shovel, and additional explanations of value for the operator.

CONTROL OF MANUALS

The destination parties of this manual are kept in a ledger by the appropriate persons in this company, so be sure to decide on someone to be placed in charge of it and who will control its use and whereabouts at all times. This person will be notified of revisions, additions and other important points whenever this company deems it necessary to do so.

MANUAL OVERVIEW

This manual is classified in the following series, and issued for each machine model.

- I. GENERAL
- II. SYSTEMS
- III. COMPONENTS
- IV. TROUBLESHOOTING
- V. ENGINE

Sheet Numbers

The following sheet numbers are assigned to each respective page. And if there are additional sheets, revisions, etc., an addition code or a revision code is supplied.

Please file the sheets in the order of the sheet numbers.

Sheet No.

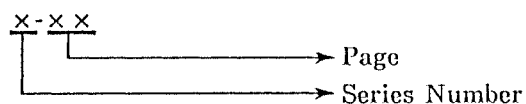

Sheet Addition



Sheet No. for III. COMPONENTS

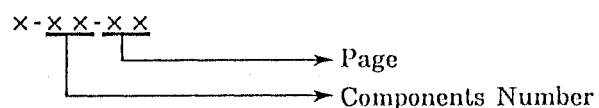

Sheet Revision

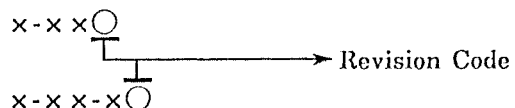

Example:

II-08

II-09

II-09-1 A page is added between page 09 and page 10.

II-10

II-11 ① Page 11 has been revised for the first time.

If a sheet has been revised, it is to be used in place of the sheet used before revision and it is not necessary to keep the old sheet.



GENERAL

I



SYSTEMS

II



COMPONENTS

III



TROUBLESHOOTING

IV



ENGINE

V



GENERAL

I

INTRODUCTION

This "GENERAL" manual includes formal precautions which are to be exercised at all times by those performing maintenance operations. Only those precautions which are absolutely necessary for safe, accurate operations are included. Be sure to follow this manual closely when performing all maintenance tasks.

We want, through future revisions of this manual, etc, to improve it and make it as complete as we possibly can. We welcome any opinions or suggestions, etc, which you may have that would help us. Please address all comments to the person in charge.

STANDARD VALUES AND ALLOWABLE VALUES

The terms used in the Service Standard table of "Maintenance Standard" and "Performance Check Judgment Standard" denote the following:

[Standard value] : It is a value based upon standards of new vehicles and vehicles shipped for field work. Use it as a target for service work after the machine is put to field operation.

[Allowable value] : The dimensions of parts change resulting from wear and distortion. Hydraulic components such as pumps and motors deteriorate performances.

The allowable value is an assumed figure which shows how long a specific part may be used and is determined with reference to standards for shipment and the results of different tests. Allowable values differ depending upon the operating condition and the history of repair of a vehicle. Use the allowable values with "Maintenance Standard" and "Performance Check Judgment Standard".

Note: Do not utilize standard values and allowable values as references for claim application.

CONTENTS

1. GENERAL	
1.1 General Precautions	03
1.2 Precautions concerning Disassembly and Reassembly	04
1.3 Precautions concerning Removing and Installing Hydraulic equipment	05
1.4 Precautions concerning Disconnecting and Connecting pipes ·	06
1.5 Handling of Seals	07
1.6 Tightening Torque	08
2. SPECIFICATIONS	
2.1 Name of Components	11
2.2 General Dimensions	12
2.3 Working Ranges of Attachments	14
2.4 Lifting-up ability Diagram	16
Precautions to be exercised in the use of the Crane (for UK)	19
2.5 Specifications of Devices	21
2.6 Hydraulic of Equipment specifications	22
2.7 Weight Table	23
2.8 List of Oil and Greases	24
2.9 List of Filter Elements	24
3. MAINTENANCE STANDARDS	
3.1 Lower System	25
3.2 Bucket	27
3.3 Attachment Pin and Bushing	28
4. PERFORMANCE CHECK JUDGMENT STANDARDS	
4.1 Hydraulic Pressure Measurements	31
4.2 Travel Test Procedure	33
4.3 Slewing Test Procedure	34
4.4 Attachment Test Procedure	35
4.5 Another Test Procedure	37
4.6 Performance Inspection Standard	39

INTRODUCTION

This "GENERAL" manual includes formal precautions which are to be exercised at all times by those performing maintenance operations. Only those precautions which are absolutely necessary for safe, accurate operations are included. Be sure to follow this manual closely when performing all maintenance tasks.

We want, through future revisions of this of this manual, etc, to improve it and make it as complete as we possibly can. We welcome any any opinions or suggestions, etc, which you may have that would help us. Please address all comments to the person in charge.

STANDARD VALUES AND ALLOWABLE VALUES

The terms used in in the Service Standard table of "Service Standard" and "Performance Judgment criterion" denote the following:

{ Standard value } : It is a value based upon standards of new vehicles and vehicles shipped for field work. Use it as a target for service work after the machine is put to field operation.

{ Allowable value } : The dimensions of parts change resulting from wear and distortion. Hydraulic components such as pumps and motors deteriorate performances.

The allowable value is an assumed figure which shows how long a specific part may be used and is determined with reference to standards for shipment and the results of different tests. Allowable values differ depending upon the operating condition and the history of repair of a vehicle. Use the allowable values with "Service Standard" and "Performance Judgment Standard".

Note: Do not utilize standard values and allowable values as references for claim application.

CONTENTS

1. GENERAL	
1.1 General Precautions	03
1.2 Precautions concerning Disassembly and Reassembly	04
1.3 Precautions concerning Removing and Installing Hydraulic equipment	05
1.4 Precautions concerning Disconnecting and Connecting pipes	06
1.5 Handling of Seals	07
1.6 Tightening Torque	08
2. SPECIFICATIONS	
2.1 Name of Components	11
2.2 General Dimensions	12
2.3 Working Ranges of Attachments	14
2.4 Lifting-up ability Diagram Precautions to be exercised in the use of the Crane (for UK)	16 19
2.5 Specifications of Devices	21
2.6 Hydraulic of Equipment specifications	22
2.7 Weight Table	23
2.8 List of Oil and Greases	24
2.9 List of Filter Elements	24
3. MAINTENANCE STANDARDS	
3.1 Lower System	25
3.2 Bucket	27
3.3 Attachment Pin and Bushing	
4. PERFORMANCE CHECK JUDGMENT STANDARDS	28
4.1 Hydraulic Pressure Measurements	31
4.2 Travel Test Procedure	33
4.3 Slewing Test Procedure	34
4.4 Attachment Test Procedure	35
4.5 Another Test Procedure	37
4.6 Performance Inspection Standard	39

1. GENERAL

1.1 GENERAL PRECAUTIONS

- (1) Wear a helmet, safety shoes and work clothing.
- (2) Check all equipment and tools, particularly equipment used for hoisting, before use.
- (3) If more than one person is working at the same time, decide on each person's personal responsibilities and signals to use, and have them keep up communications between each other as they proceed.
- (4) The person operating a crane and using sling equipment should be a person with the proper qualifications.
- (5) Absolutely do not get underneath a suspended load.
- (6) Before removing the mounting bolts of heavy parts, suspend them temporarily with a crane to provide adequate support.
- (7) If the machine's hoe attachment, etc. is raised up and a maintenance person gets underneath it, be sure to support the machine with stands, etc.
- (8) When repairing the electrical system, disconnect the cables to the battery before starting work.
- (9) Disconnect the battery when performing welding operations on the machine.
- (10) Tighten all pipes and bolts, etc, to the specified tightening torques.
- (11) After repairs are completed, run the engine at low speed and carry out trial operation after filling the hydraulic system full with hydraulic fluid.

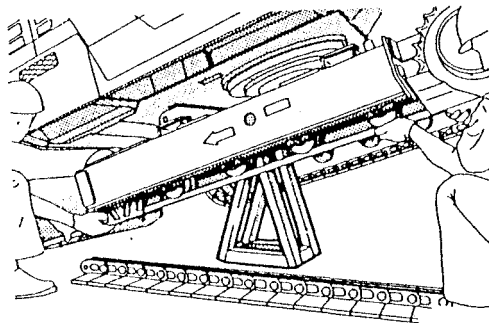
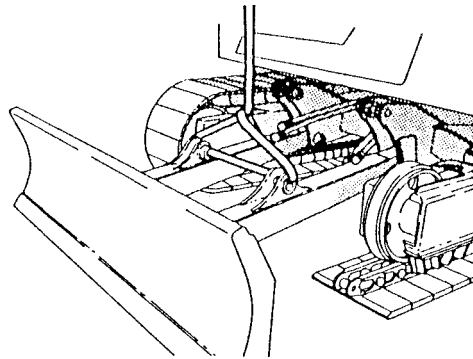

1.2 PRECAUTIONS CONCERNING DISASSEMBLY AND REASSEMBLY

- (1) The machine should be cleaned before beginning disassembly operations.
- (2) Check the machine before disassembly and keep a record which includes the following items.
 - Model, Serial No., Hour Meter
 - Reason for Repairs, Repair History
 - Dirt in Filters
 - Condition of Fuel and Oil
 - Damage to Each Part, etc.
- (3) To make reassembly easier, make matching marks in all the necessary locations.
- (4) Be sure to clean all disassembled parts and all new parts and keep them in the correct order during the entire operation.
- (5) Be sure to replace all seals and split pins, etc. with new parts.
- (6) Separate parts which come in contact with water or hydraulic fluid from parts covered with engine oil, etc. and keep them in that condition during maintenance operations.
 - Electrical Parts, Rubber Parts, V-belts, etc.
- (7) When fitting bearings, bushings and oil seals, as a rule, a press should be used. If a hammer or similar tool must be used, be sure to place a driving block, etc. between the part and the hammer.
- (8) Companion surfaces of parts should be wiped clean of all dirt, etc. before assembly.
- (9) Seal tape should be wound tightly around pipes with the first 1 or 2 threads left exposed at the end, and the tape should overlap itself by about 10 mm (0.39").

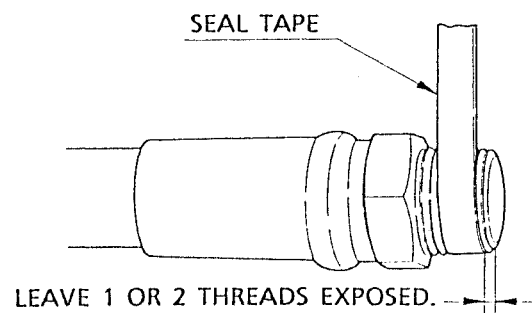

1.3 PRECAUTIONS CONCERNING REMOVING AND INSTALLING HYDRAULIC EQUIPMENT

- (1) Make sure the temperature of the hydraulic fluid has dropped first.
- (2) To prevent the loss of hydraulic fluid, bleed the internal pressure from the hydraulic pipes and from the hydraulic fluid tank.
- (3) Be sure to cover openings in the hydraulic equipment with caps, plugs, etc. to prevent dirt from getting into the hydraulic system.

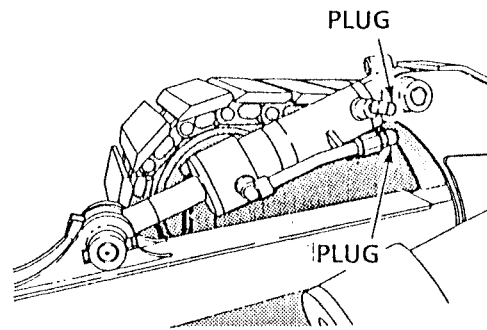

- (4) It is easy to mistake hydraulic fluid left on hydraulic equipment for an oil leak, so be sure to wipe off all drips completely.
- (5) Be careful not to get scratches on the plated portions of hydraulic cylinder rods.
- (6) When removing and installing a hydraulic cylinder, as a rule, the rod should be in the fully retracted condition.
- (7) After installing the hydraulic cylinder, be sure to bleed out all air. See the item in "IV. Hydraulic Equipment, Cylinder".
- (8) After installing hydraulic equipment, be sure to pressurize the hydraulic fluid tank. If this is forgotten, cavitation could occur in the hydraulic pump. The service life of the hydraulic pump could also be markedly affected.
 - Pressurization of the Hydraulic Fluid Tank
Lower the dozer blade to the ground. Except for the dozer blade cylinder, extend all the hydraulic cylinders fully. In this state, loosen the air bleeder plug on the cover of the hydraulic fluid tank to equalize the tank's pressure with the atmospheric pressure. Then close the bleeder plug and seal the hydraulic fluid tank.

1.4 PRECAUTIONS CONCERNING DISCONNECTING AND CONNECTING PIPES

- (1) When installing hydraulic hoses, first tighten them to the specified torque, then loosen them slightly and tighten them again to the specified torque.
 - Tighten fittings after they have been worn in.
 - This does not apply to fittings which are wound with seal tape.
- (2) When installing pipes for hydraulic piping, tighten the nut and from the point where the reaction force suddenly increases greatly the sharp torque rise point, tighten the nut a further $1/4 \sim 1/2$ turn.
- (3) During removal and installation, use two wrenches, holding the hose or pipe with one and turning the fitting with the other, to keep the hose or pipe from being twisted.

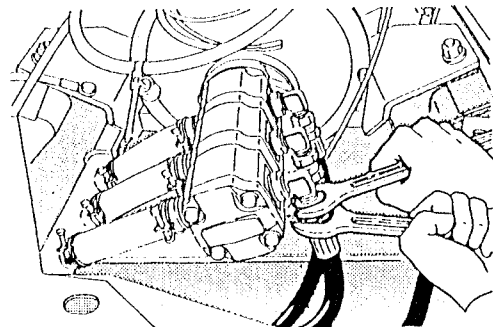

- (4) After installing a hydraulic hose or pipe for piping, make sure there is no fluid leakage even when the maximum use pressure is applied 5 or 6 times.

1.5 HANDLING OF SEALS

- (1) Clean O ring grooves and remove any burrs, etc. from them.

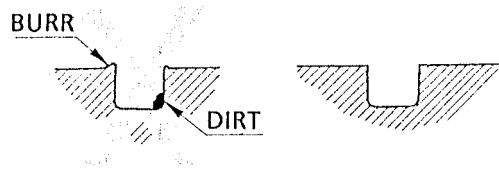

- (2) Be careful to keep O rings from becoming twisted. If they become twisted, the twisting should be removed with a fingertip.

- (3) Be careful so that seals are not scratched during insertion.

(4) Handling of Floating Seals

- Oil on O rings and housings should be completely wiped off when removing floating seals.
- Before fitting, apply a light coating of gear oil to the companion surface of the housing.
- After assembly, turn the seal 2 or 3 times so that it is seated properly.

(5) Apply grease to the lips of oil seals

- This prevents wear the first time the machine is started up after assembly.

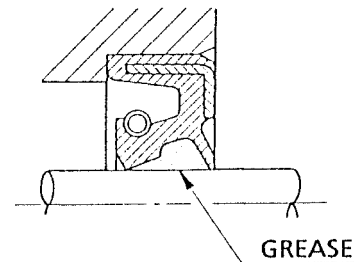

GENERAL

GENERAL PRECAUTIONS

1.6 TIGHTENING TORQUES

HYDRAULIC HOSE

HOSE FITTING SIZE	TIGHTENING TORQUE Kgf·m (ft·lbs)	
	UNION NUT (PF)	TAPERED THREADS (PT)
1/8	$1^{+0.5}_0$ (7.23 $^{+3.6}_0$)	$1.2^{±0.12}$ (8.68 $^{±0.87}$)
1/4	$2.5^{±0.5}_0$ (18.1 $^{+3.6}_0$)	$3.0^{±0.30}$ (21.7 $^{±2.2}$)
3/8	$5^{+0.5}_0$ (36.2 $^{+3.6}_0$)	$5.5^{±0.55}$ (39.8 $^{±4.0}$)
1/2	$6^{+0.5}_0$ (43.4 $^{+3.6}_0$)	$9.0^{±0.90}$ (65.1 $^{±6.5}$)
3/4	$12^{+0.5}_0$ (86.8 $^{+3.6}_0$)	$15.0^{±1.50}$ (108 $^{±11}$)
1	$14^{+0.5}_0$ (101 $^{+3.6}_0$)	$20.0^{±2.00}$ (145 $^{±14}$)

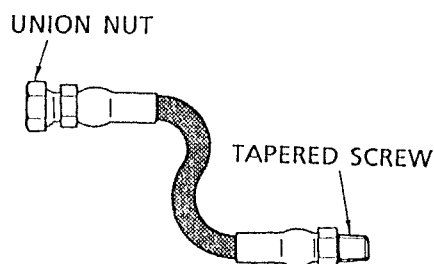

STEEL PIPE THRUST COUPLINGS

OUTER DIAMETER OF STEEL PIPE mm	TIGHTENING TORQUE Kgf·m (ft·lbs)
8	$3.5^{±0.5}$ (25.3 $^{±3.6}$)
10	$4.25^{±0.5}$ (30.7 $^{±3.6}$)
12	$6.0^{±0.5}$ (43.4 $^{±3.6}$)
15	$9.0^{±0.5}$ (65.1 $^{±3.6}$)
16	$9.5^{±0.5}$ (68.7 $^{±3.6}$)
18	$13.5^{±0.5}$ (97.6 $^{±3.6}$)
22	$21.0^{±1.0}$ (152 $^{±7}$)
27.2	$25.0^{±1.0}$ (181 $^{±7}$)
28	$32.0^{±2.0}$ (232 $^{±15}$)
32	$32.0^{±2.0}$ (232 $^{±15}$)
35	$42.0^{±2.0}$ (304 $^{±15}$)

