

CRAWLER CRANE

SHOP
MANUAL

CK850-II
model **CKE800**
CKE700

KOBELCO

BOOK CODE : S5GG00005ZE04

SAFETY

1. SPECIFICATION

1.1 CK850-II SPECIFICATION 1-3

1.1.1 PERFORMANCE 1-3

1.1.2 OUTSIDE DIMENSIONS 1-3

1.1.3 DIMENSIONS AND WEIGHT OF EACH PARTS 1-5

1.1.4 CK850-II STABILITY IN SWINGING AND TRAVELING 1-10

1.2 CKE800/CKE700 SPECIFICATION 1-11

1.2.1 PERFORMANCE 1-11

1.2.2 OUTSIDE DIMENSIONS 1-11

1.2.3 DIMENSIONS AND WEIGHT OF EACH PARTS 1-13

1.2.4 CKE800 STABILITY IN SWINGING AND TRAVELING 1-19

1.2.5 CKE700 STABILITY IN SWINGING AND TRAVELING 1-21

2. MAINTENANCE STANDARDS

TEST PROCEDURES

2.1 MAINTENANCE STANDARD 2-3

2.1.1 PIN, BUSHING, SPRING, LINING AND SHEAVE 2-3

2.1.2 PROPEL DEVICE 2-10

2.2 PERFORMANCE STANDARD AND TEST PROCEDURE 2-16

2.2.1 OPERATING SPEED 2-16

2.2.2 POINT AND METHOD OF MEASURING PRESSURE 2-17

2.2.3 SLEWING RING 2-21

3. GENERAL WORK STANDARD

3.1 TIGHTENING TORQUE OF CAPSCREWS AND NUTS 3-3

3.1.1 METRIC COARSE THREADS 3-3

3.1.2 METRIC FINE THREADS 3-3

3.1.3 COARSE THREDS UNC 3-4

3.1.4 FINE THREADS UNF 3-4

3.1.5 TIGHTENING TORQUE OF HYDRAULIC FITTINGS 3-5

3.2 STANDARD PARTS 3-7

3.2.1 BOLT 3-7

3.2.2 O-RING 3-8

3.2.3 BACK-UP RING 3-9

3.2.4 BITE FITTING 3-10

3.3 CONVERSION TABLE 3-12

3.3.1 UNIT CONVERSION 3-12

3.3.2 MILLIMETER : INCH CONVERSION TABLE 3-13

TABLE OF CONTENTS

3.3.3	METER-FOOT CONVERSION TABLE	3-15
3.3.4	GRADIENT CONVERSION TABLE	3-16
3.4	TABLE OF UNIT WEIGHT	3-17
4. POWER TRAIN		
4.1	INTRODUCTION.....	4-3
4.2	ENGINE.....	4-5
4.2.1	INTRODUCTION	4-5
4.2.2	REMOVAL	4-5
4.2.3	REPAIR AND MAINTENANCE	4-6
4.2.4	RE-INSTALLATION.....	4-7
4.3	PUMP DRIVE ASSEMBLY.....	4-11
4.3.1	INTRODUCTION	4-11
4.3.2	REMOVAL	4-11
4.3.3	DISASSEMBLING THE POWER DIVIDER.....	4-13
4.3.4	CHECK AND REPAIR OF THE POWER DIVIDER.....	4-14
4.3.5	ASSEMBLING THE POWER DIVIDER.....	4-15
4.3.6	RE-INSTALLATION.....	4-16
5. HYDRAULIC SYSTEM		
5.1	LOCATION OF MAIN HYDRAULIC COMPONENTS	5-3
5.2	HYDRAULIC CIRCUITS AND COMPONENTS	5-4
5.2.1	HYDRAULIC CIRCUIT	5-4
5.2.2	COMPONENT SPECIFICATIONS	5-7
5.2.3	LOCATION OF HYDRAULIC COMPONENTS.....	5-10
5.3	HYDRAULIC SYSTEM.....	5-17
5.3.1	PREFACE.....	5-17
5.3.2	OUTLINE	5-17
5.3.3	OIL FLOW FROM No.1 and No. 2 PUMPS.....	5-19
5.3.4	OIL FLOW FROM No.3 PUMP.....	5-22
5.3.5	OIL FLOW FROM No.4 and No.5 PUMPS (FOR MAIN AND AUX. WINCH DRUMS BRAKE COOLING CIRCUIT).....	5-24
5.3.6	OIL FLOW FROM No.6 PUMP (CONTROL PUMP)	5-25
5.3.7	OIL FLOW FROM No.7 PUMP (FOR AUXILIARY ACTUATOR CIRCUIT).....	5-28
5.4	VALVES	5-29
6. HOIST SYSTEM		
6.1	APPARATUS AND LOCATION OF COMPONENTS.....	6-3
6.2	CONSTRUCTION AND FUNCTION	6-4
6.2.1	HYDRAULIC SCHEMATIC.....	6-4

TABLE OF CONTENTS

6.2.2	LIFTING A LOAD	6-6
6.2.3	HOLDING A RAISED LOAD	6-8
6.2.4	LOWERING A LOAD (POWERED LOWERING)	6-10
6.2.5	FREEFALL OPERATION	6-13
6.2.6	FREE FALL ACCELERATION.....	6-16
6.2.7	FRONT DRUM/REAR DRUM HYD-CIRCUIT SELECTION	6-19
6.3	ADJUSTMENT OF DRUM LOCK.....	6-22
6.4	BRAKE PEDAL.....	6-24
6.4.1	ASSEMBLY DRAWING	6-24
6.4.2	ADJUSTING THE BRAKE PEDAL	6-26
6.5	BLEEDING AIR FROM BRAKE CIRCUIT	6-27
7. BOOM HOIST SYSTEM		
7.1	APPARATUS AND LOCATION OF COMPONENTS	7-3
7.2	CONSTRUCTION AND FUNCTION	7-5
7.2.1	HYDRAULIC SCHEMATIC	7-5
7.2.2	RAISING THE BOOM.....	7-6
7.2.3	NEUTRAL (MAINTAINING THE BOOM POSITION)	7-8
7.2.4	LOWERING THE BOOM	7-10
7.3	BOOM DRUM LOCK.....	7-12
7.3.1	ASSEMBLY DRAWING	7-12
7.3.2	ADJUSTING THE BOOM DRUM LOCK.....	7-13
7.4	REDUCTION UNIT	7-14
8. SWING SYSTEM		
8.1	APPARATUS AND LOCATION OF COMPONENTS	8-3
8.2	CONSTRUCTION AND FUNCTION	8-4
8.2.1	HYDRAULIC SCHEMATIC	8-4
8.2.2	SWING.....	8-6
8.2.3	STOPPING	8-8
8.3	SWING REDUCTION UNIT.....	8-10
8.4	SWING BEARING	8-14
8.5	SWING LOCK.....	8-16
9. PROPEL SYSTEM		
9.1	LOCATION OF THE MAJOR COMPONENTS.....	9-3
9.2	CONSTRUCTION AND FUNCTION	9-4

TABLE OF CONTENTS

9.2.1	HYDRAULIC SCHEMATIC.....	9-4
9.2.2	PROPELLING (RIGHT SIDE FORWARD).....	9-6
9.2.3	STOPPING.....	9-8
9.3	PROPEL REDUCTION UNIT.....	9-10
9.3.1	REDUCTION UNIT.....	9-12
9.3.2	MOTOR.....	9-14
9.4	ADJUSTMENT.....	9-16
10. ELECTRIC SYSTEM		
10.1	ELECTRICAL WIRING SCHEMATIC.....	10-3
10.2	CONNECTOR LIST.....	10-15
10.3	ARRANGEMENT OF ELECTRICAL PART.....	10-67
10.3.1	ELECTRICAL PART OF CAB.....	10-67
10.3.2	ELECTRICAL PART OF RIGHT DECK.....	10-70
10.3.3	ELECTRICAL PART OF FLOOR PLATE & LEFT SIDE STAND PANEL.....	10-78
10.3.4	ELECTRICAL PART OF REVOLVING FRAME.....	10-83
10.3.5	ELECTRICAL PART OF LEFT DECK.....	10-84
10.3.6	ELECTRICAL PART OF LEFT GUARD.....	10-88
10.3.7	HARNESS PART NUMBER LIST (ALL MODELS).....	10-89
10.4	ELECTRICAL PART.....	10-91
10.4.1	LOCATION AND USE OF FUSE.....	10-91
10.4.2	FUSE BOX (GG73E00004F1).....	10-93
10.4.3	WIPER CONTROL RELAY (2479R1366).....	10-95
10.4.4	SWING FLASHER UNIT (2480U306).....	10-96
10.4.5	PRESSURE SWITCH (CONTROL PRESSURE CUT & FREE FALL).....	10-97
10.4.6	PRESSURE SENSOR.....	10-98
10.4.7	RELAY BOX (GG24E00024F1).....	10-100
10.4.7.1	ARRANGEMENT OF CONNECTOR.....	10-100
10.4.7.2	RELAY BOX SCHEMATIC.....	10-102
10.4.8	LEFT SIDE STAND PANEL.....	10-105
10.5	TROUBLESHOOTING OF EXHAUST GAS THIRD REGULATION ENGINE.....	10-109
10.5.1	FAILURE DIAGNOSIS FUNCTION.....	10-109
10.5.2	HOW TO CHECK THE FAILURE CONTENTS.....	10-110
10.5.3	CHECKING OF DIAGNOSIS LAMP FUNCTION.....	10-115
10.5.4	ENGINE ECU.....	10-116
11. LOAD SAFETY DEVICE		
11.1	PART NAMES AND FUNCTIONS.....	11-3
11.1.1	FRONT VIEW.....	11-3
11.1.2	CONFIGURATION OF SCREENS.....	11-8

TABLE OF CONTENTS

11.1.3 DATA TRANSMISSION BETWEEN CONTROLLER AND CARDS	11-13
11.1.4 DETAILS OF INDICATORS ON MAIN DISPLAY SCREEN	11-15
11.1.5 REAR VIEW.....	11-19
11.1.6 ITEMS REQUIRED TO BE EXECUTED FOR REPLACEMENT OF CONTROLLER OR DATA CARD AND INSTRUCTIONS (IN A SIMILAR MANNER TO UPGRADE OF PROGRAM)	11-24
11.2 PREPARATION FOR USE.....	11-25
11.3 TURN THE POWER ON	11-26
11.4 UPGRADING PROGRAMS.....	11-27
11.4.1 PROCEDURES	11-27
11.4.2 UPGRADING OF INDICATION PROGRAMS	11-29
11.4.3 UPGRADING OF CONTROL PROGRAMS	11-32
11.5 STATUS CHECK.....	11-34
11.5.1 SIGNAL CHECK.....	11-35
11.5.2 OPERATION PROGRESS	11-37
11.5.3 COMMUNICATION DATA	11-40
11.5.4 INDICATION OF ADJUSTMENT VALUE	11-41
11.5.4.1 ANGLE SENSOR ADJUSTMENT VALUE.....	11-42
11.5.4.2 LOAD CELL ZERO POINT ADJUSTMENT VALUE	11-43
11.5.4.3 ADJUSTMENT VALUE OF LOAD CELL FOR LINE-PULL	11-44
11.5.4.4 RESULT OF MANUFACTURE ADJUSTMENTS "NO LOAD" AND "SOME LOAD"	11-45
11.5.4.5 RESULT OF LOAD ADJUSTMENTS "NO LOAD" AND "SOME LOAD" ..	11-46
11.5.4.6 ADJUSTMENT VALUE OF WORKING RADIUS	11-47
11.5.4.7 ALTERATION OF ADJUSTED VALUE.....	11-48
11.5.4.8 DELETION OF ADJUSTED VALUE	11-49
11.5.5 TROUBLE RECORD	11-50
11.5.6 CHOICE OF LANGUAGE (CKE SERIOUS ONLY).....	11-52
11.5.7 LOAD RECORD (LOAD RECORD IN THE MAIN MENU).....	11-53
11.6 ADJUSTMENTS	11-54
11.6.1 REMOVING THE INNER PANEL	11-54
11.6.2 ADJUSTMENT.....	11-55
11.6.2.1 ANGLE SENSOR ADJUSTMENT	11-58
11.6.2.2 LOAD CELL ZERO POINT ADJUSTMENT	11-62
11.6.2.3 LOAD-LESS ADJUSTMENT & SOME LOAD ADJUSTMENT.....	11-64
11.6.2.4 LVL ADJUSTMENT (LVL SETTING).....	11-71
11.6.2.5 RADIUS ADJUSTMENT	11-74
11.6.3 LOAD ADJUSTMENT	11-76
11.6.4 ADJUSTMENT DATA COPY (INITIALIZATION)	11-78
11.6.4.1 READING OF THE ADJUSTMENT DATA.....	11-80
11.6.4.2 WRITING OF ADJUSTMENT DATA.....	11-82
11.6.4.3 INITIALIZATION OF ADJUSTMENT DATA.....	11-83
11.6.5 VERSION CHECK.....	11-84

TABLE OF CONTENTS

11.7 ERROR CODE (ABNORMALITY DETECTION) AND COUNTERMEASURES ...	11-85
11.8 CONTROL OUTPUT	11-89
11.9 RELEASES	11-101
11.9.1 RELEASE FUNCTION	11-101
11.9.1.1 CRANE RELEASE CHART	11-101
11.9.1.2 ALARM SOUND	11-107
11.9.1.3 EXTERNAL INDICATOR LAMPS IN RELEASE CONDITION	11-108
11.10 MECHANICAL SPECIFICATION.....	11-109
11.10.1 ENVIRONMENTAL PERFORMANCE PARAMETERS.....	11-109
11.10.2 LOAD CELL (CRANE).....	11-110
11.10.3 ANGLE SENSOR	11-111
11.10.4 CONTROLLER.....	11-112
11.10.4.1 MODEL NAME.....	11-112
11.10.4.2 SYSTEM INPUT/OUTPUT	11-112
11.10.4.3 MONITOR DISPLAY.....	11-114
11.10.4.4 OPERATION SWITCH	11-114
11.10.4.5 INTERNAL PROCESSING SYSTEM	11-114
11.10.4.6 MEMORY.....	11-114
11.10.4.7 EXTERNAL STORAGE ELEMENT	11-115
11.10.4.8 OTHERS.....	11-115
11.11 EXTERNAL DIMENSIONS	11-116
11.12 ELECTRIC SCHEMATIC DIAGRAM	11-117
11.12.1 CRANE TYPE.....	11-117
11.12.2 LUFFING TYPE.....	11-118
11.13 CONTROLLER MALFUNCTION EMERGENCY MEASURES.....	11-119
11.14 LOAD SAFETY DEVICE CHECK PROCEDURES.....	11-120
12. GAUGE CLUSTER	
12.1 CONFIGURATION OF DISPLAY	12-3
12.2 PRIORITY	12-4
12.3 STATUS DISPLAY	12-6
12.4 FAULT LOG DISPLAY	12-15
13. TOTAL CONTROLLER	
13.1 ARRANGEMENT OF TOTAL CONTROLLER	13-3
13.2 COMPOSITION OF SYSTEM	13-4
13.2.1 OUTPUT RELATION TO CONTROLLER	13-5
13.3 FUNCTION OF TOTAL CONTROLLER.....	13-6
13.4 TOTAL CONTROLLER (HARDWARE).....	13-29
13.4.1 OUTLINE.....	13-29
13.4.2 SPECIFICATIONS OF TOTAL CONTROLLER OUTPUT.....	13-30

TABLE OF CONTENTS

13.4.3	DETAILS OF TOTAL CONTROLLER CONNECTOR	13-34
13.4.4	ARRANGEMENT OF TOTAL CONTROLLER CONNECTOR PIN	13-35
13.4.5	PROPORTIONAL SOLENOID VALVE MEASURING POSITION (VOLTAGE).....	13-42
13.5	ADJUSTMENT OF TOTAL CONTROLLER	13-44
13.5.1	NECESSITY OF ADJUSTMENT	13-44
13.5.2	ADJUSTMENT PROCEDURES OF TOTAL CONTROLLER	13-44
13.5.2.1	OPTION SETTING.....	13-44
13.5.2.2	ADJUSTMENT OF HAND THROTTLE AND FOOT THROTTLE	13-46
13.5.2.3	ENGINE SPEED ADJUSTMENT	13-47
13.5.2.4	WHEN ADJUSTMENT OF TOTAL CONTROLLER IS IMPOSSIBLE	13-48
13.5.2.5	INITIAL ADJUSTMENT OF LIFTING HEIGHT GAUGE	13-49
13.6	CONTROLLER MALFUNCTION EMERGENCY MEASURES.....	13-51

14. AIR CONDITIONER

14.1	OPERATION ITEMS	14-3
14.2	SAFETY MONITOR FUNCTIONS.....	14-4
14.3	DISASSEMBLY AND ASSEMBLY PROCEDURE	14-7
14.3.1	SPECIAL CONSIDERATIONS DURING REPLACEMENT	14-7
14.3.2	INTERIOR UNIT	14-9
14.3.2.1	CASE DISASSEMBLY.....	14-9
14.3.2.2	THERMOSTAT REPLACEMENT	14-12
14.3.2.3	EVAPORATOR OR EXPANSION VALVE REPLACEMENT	14-13
14.3.2.4	HEATER CORE REPLACEMENT	14-14
14.3.2.5	INTAKE DUMPER ACTUATOR REPLACEMENT.....	14-15
14.3.2.6	WATER VALVE ACTUATOR OR WATER VALVE REPLACEMENT.....	14-16
14.3.2.7	MODE ACTUATOR REPLACEMENT	14-17
14.3.2.8	BLOWER MOTOR ASSEMBLY REPLACEMENT.....	14-17
14.4	OPERATIONAL PRECAUTIONS	14-18
14.5	INSPECTION AND MAINTENANCE	14-19
14.5.1	INSPECTION/MAINTENANCE LIST	14-19
14.5.2	INSPECTION/MAINTENANCE PROCEDURES	14-19
14.6	ELECTRIC SYSTEM SCHEMATIC.....	14-23

TABLE OF CONTENTS

SAFETY

This section explains "Explanation of Warning Description", "Warning Labels" and "General safety"

EXPLANATION OF WARNING DESCRIPTION

This manual indicates the contents of warnings concerned in safety with the following three stages according to the degree of personal harm and material damage.

Since the very important matters for safety are described, understand the contents sufficiently and observe them without fail.



Warning to avoid dangerous condition resulting in instantaneous death or serious personal injury.



Warning to avoid dangerous condition which has possibility of death or serious personal injury.



Warning to avoid dangerous condition which has possibility to cause slight or medium injury or damage of the machine and equipments.

This manual describes safety warnings sufficiently, but dangerous conditions which are impossible to be anticipated are considered.

Therefore, take measures for safety not only regarding the machine, but also including the working environment.

EXPLANATION OF WARNING LABELS

Since the warning labels are installed in the machine and indicated with the three stages in the same way as the warning description, confirm the positions and contents all warning labels first.

Put them to the practical use to secure safety when operating, checking and performing maintenance.

- **HANDLING OF WARNING LABELS**

1. When the warning label is damaged or stained, order it to the designated service shop.
2. Do not remove the warning labels.
3. When the surface of the warning label is soiled and difficult to be seen, wipe it cleanly.

⚠ DANGER
 NEVER FORGET TO ENGAGE
 GANTRY CONNECTION PINS
 TO AVOID FALLING OF BOOMS. GANTRY
 CONNECTION PINS MUST BE ENGAGED
 WHEN GANTRY IS AT HIGH POSITION.
 ALSO, LOWER PARTS OF TENSION BARS
 MUST BE CONNECTED TO REVOLVING FRAME
 OR COUNTERWEIGHT WHEN GANTRY IS AT
 LOW POSITION.
FP20T01046P1

⚠ DANGER
 When lock pin is not installed,
 do not stand under gantry.
JJ20T01097P1

⚠ CAUTION
 Moving parts.
JJ20T01086P1

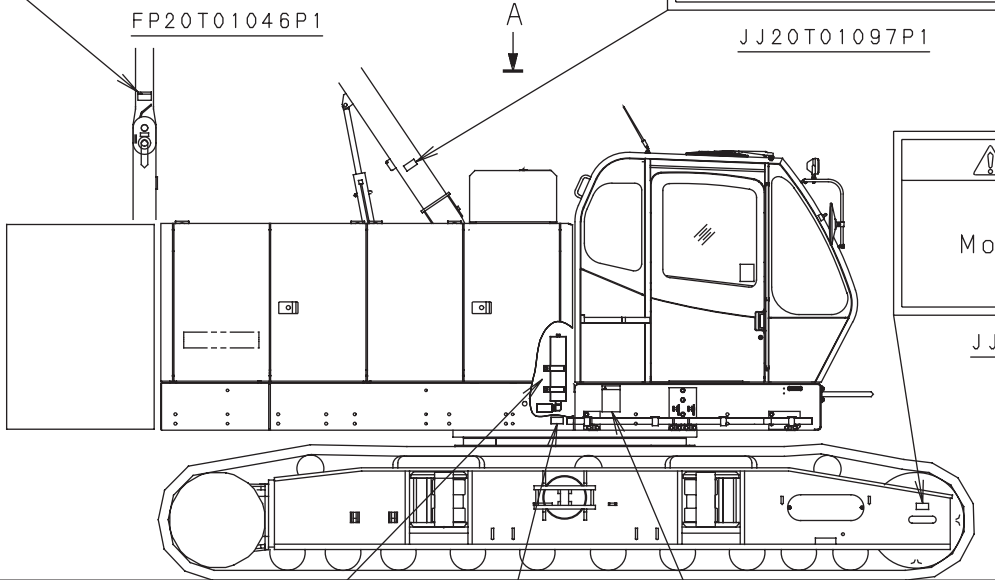

⚠ CAUTION
 Stay out from
 crane swing area.
JJ20T01095P1

⚠ DANGER
 DEATH OR INJURY MAY RESULT IF
 MACHINE, LOAD, OR LOAD LINE TOUCHES
 OR COMES CLOSE TO ELECTRICAL LINES.
 ALWAYS MAINTAIN A CLEARANCE OF
 AT LEAST 10 FEET (3 METERS)
 BETWEEN THE CRANE OR THE LOAD
 BEING HANDLED AND POWERLINES.
 UNLAWFUL TO PLACE ANY PART OF
 THIS MACHINE OR LOAD WITHIN 10 FEET
 (3 METERS) OF HIGH VOLTAGE LINES OF
 50,000 VOLTS OR LESS.
 GREATER CLEARANCES ARE REQUIRED
 FOR HIGHER VOLTAGES. SEE YOUR LOCAL
 STATE, AND FEDERAL REGULATIONS.
 ALWAYS NOTIFY ELECTRIC COMPANY IF
 THERE ARE ELECTRIC LINES IN THE AREA
 WHERE MACHINE WILL BE WORKING.
GG20T01127P1

ACCUMULATOR
 CHARGING GAS PRESSURE.
 3.4~3.7Mpa
 (35 ~38 Kg/cm²)
GG20T01079P1

⚠ WARNING
 AVOID EXPLOSION WHEN
 HANDLING ACCUMULATOR
 THIS CASE IS CHARGED WITH
 HIGH PRESSURE NITROGEN GAS.
 NEVER ATTEMPT TO WELD, GAS-CUT,
 PUT ON FIRE, NOR DISASSEMBLE
 THE CASE TO AVOID EXPLOSION.
FP20T01042P1

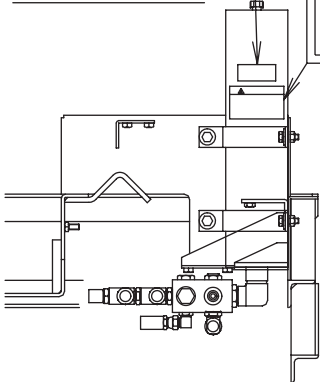

DETAIL C
 (ACCUMULATOR)

GG20T01127P1

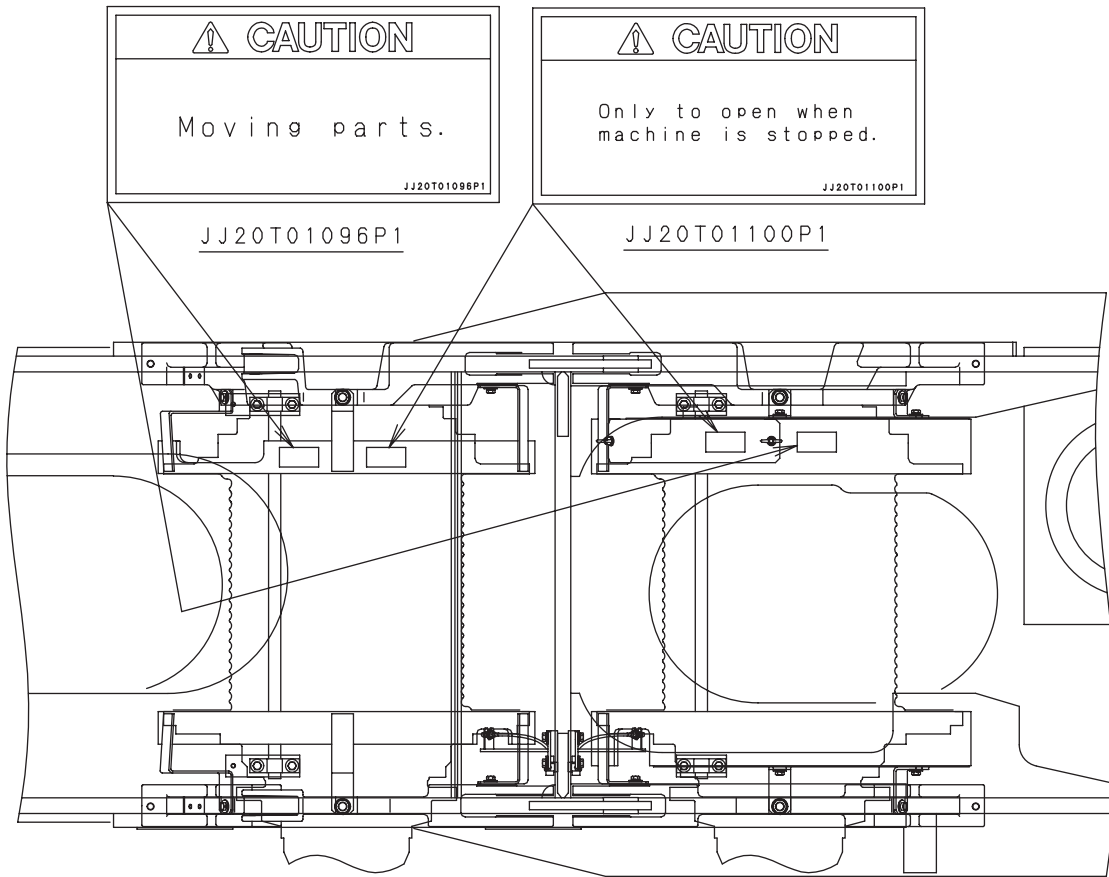

⚠ CAUTION
Moving parts.
JJ20T01096P1

⚠ CAUTION
Only to open when
machine is stopped.
JJ20T01100P1

JJ20T01096P1

JJ20T01100P1

VIEW A

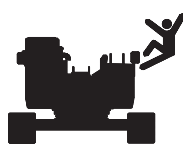
⚠ WARNING

WALKING ON GUARDS MAY CAUSE STUMBLING AT PROJECTED ITEMS AND SLIPPING BY OIL, WATER, OR GREASE.
PROTECTOR SHOULD BE EMPLOYED WHEN WALKING FOR MAINTENANCE JOB, TO AVOID TIPPING OVER AND FALLING DOWN FROM THE MACHINE.
FP20T01051P1

FP20T01051P1

⚠ CAUTION
Do not crush.
Important part
inside.
FP20T01064P1

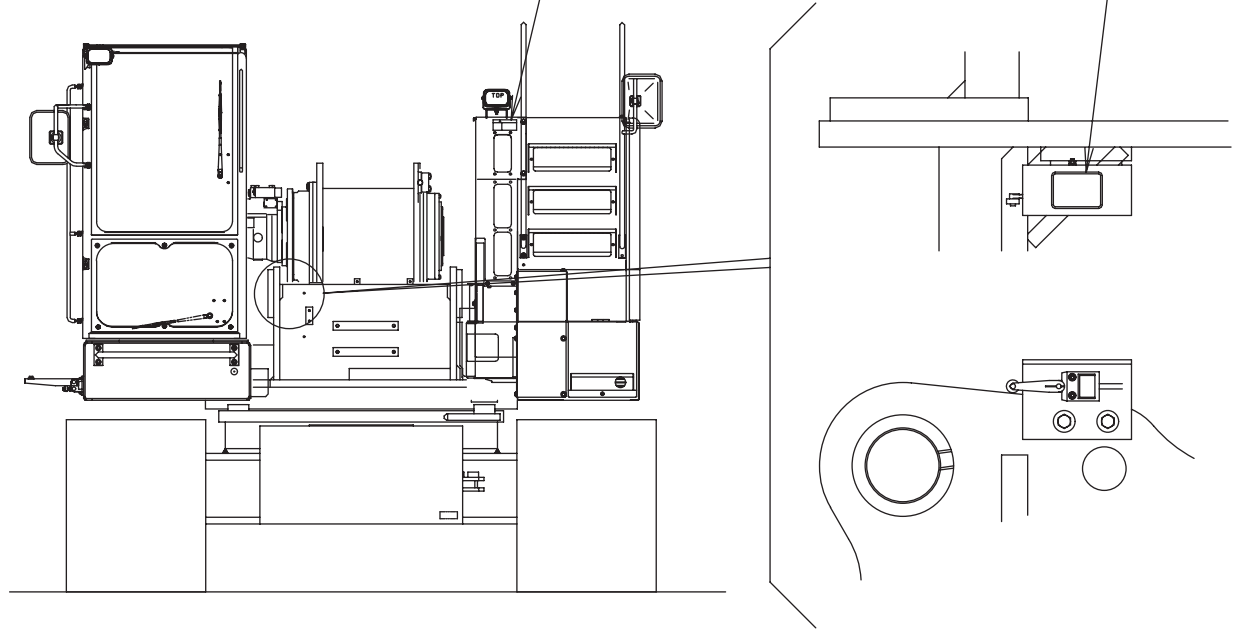
FP20T01064P1



⚠ WARNING

Steam of hot coolant can cause injury or blindness.

Never loosen or open radiator cap when coolant is hot and under pressure.

Before opening radiator cap:

- Cool down engine completely.
- Cover radiator with cloth rag.
- Loosen cap slowly to relieve pressure.

YN20T01010P1

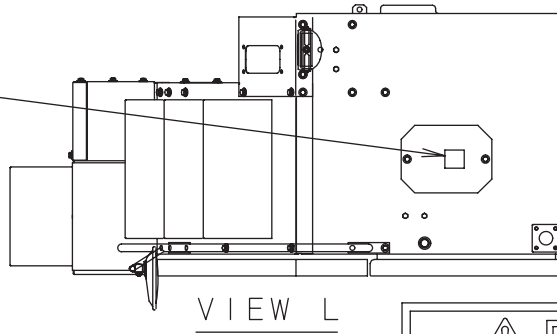

⚠ CAUTION

Only to open when engine is stopped.

JJ20T01098P1

JJ20T01098P1

⚠ DANGER

When lock pin is not installed, do not stand under gantry.

JJ20T01097P1

JJ20T01097P1

⚠ DANGER

NEVER FORGET TO ENGAGE GANTRY CONNECTION PINS

TO AVOID FALLING OF BOOMS, GANTRY CONNECTION PINS MUST BE ENGAGED WHEN GANTRY IS AT HIGH POSITION. ALSO, LOWER PARTS OF TENSION BARS MUST BE CONNECTED TO REVOLVING FRAME OR COUNTERWEIGHT WHEN GANTRY IS AT LOW POSITION.

FP20T01046P1

FP20T01046P1

⚠ CAUTION

Moving parts.

JJ20T01096P1

JJ20T01096P1

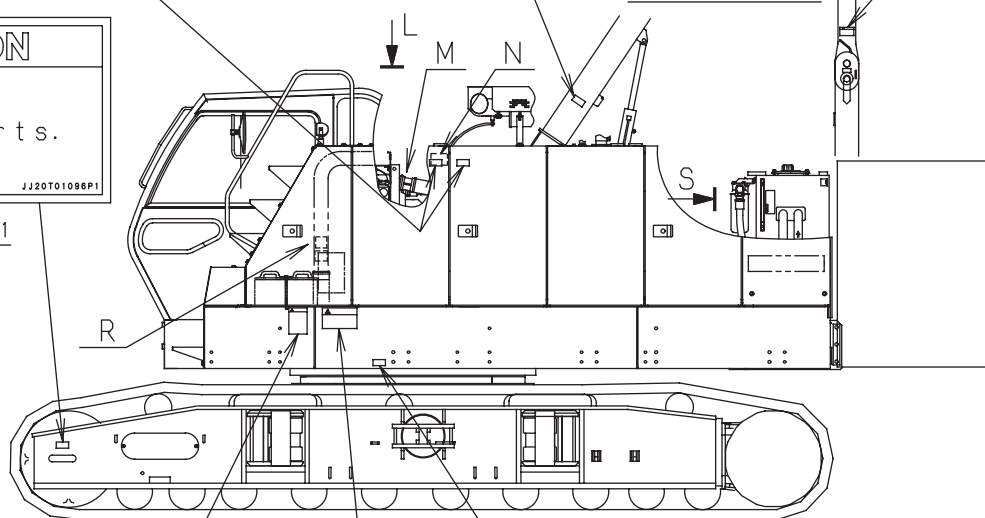

⚠ DANGER

DEATH OR INJURY MAY RESULT IF MACHINE, LOAD, OR LOAD LINE TOUCHES OR COMES CLOSE TO ELECTRICAL LINES.

ALWAYS MAINTAIN A CLEARANCE OF AT LEAST 10 FEET (3 METERS) BETWEEN THE CRANE OR THE LOAD BEING HANDLED AND POWERLINES.

UNLAWFUL TO PLACE ANY PART OF THIS MACHINE OR LOAD WITHIN 10 FEET (3 METERS) OF HIGH VOLTAGE LINES OF 50,000 VOLTS OR LESS.

GREATER CLEARANCES ARE REQUIRED FOR HIGHER VOLTAGES. SEE YOUR LOCAL, STATE, AND FEDERAL REGULATIONS.

ALWAYS NOTIFY ELECTRIC COMPANY IF THERE ARE ELECTRIC LINES IN THE AREA WHERE MACHINE WILL BE WORKING.

GG20T01127P1

GG20T01127P1

⚠ CAUTION

Stay out from crane swing area.

JJ20T01095P1

JJ20T01095P1

⚠ DANGER

STAY AWAY FROM MACHINE IF CLOSE TO POWER LINES. MACHINE, LOAD AND GROUND MAY BECOME ELECTRIFIED AND DEADLY.

GG20T01128P1

GG20T01128P1

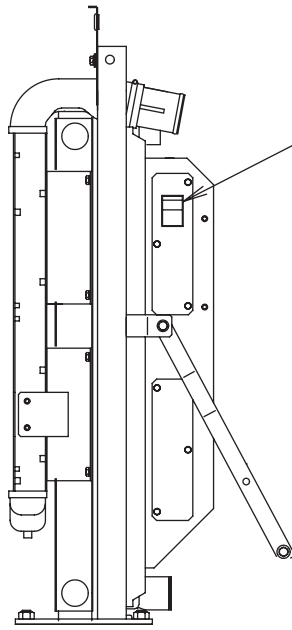

DETAIL M

⚠ WARNING

Rotating parts can cause personal injury.

Keep away from fan and belt when engine is running.

Stop engine before servicing.

YN20T01009P1

YN20T01009P1

⚠ CAUTION

CAUTION

FOR HIGH TEMPERATURE

AS ENGINES AND MUFFLERS MAY BE HEATED TO HIGH TEMPERATURES, DO NOT DIRECTLY TOUCH THEM BY HAND.

FP20T01043P1

FP20T01043P1

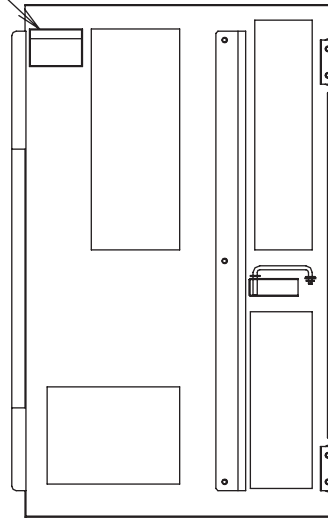

DETAIL N
(VIEW FROM INNER OF DOOR)

⚠ DANGER

KEEP CLEAR OF SWING AREA

YN20T01003P2

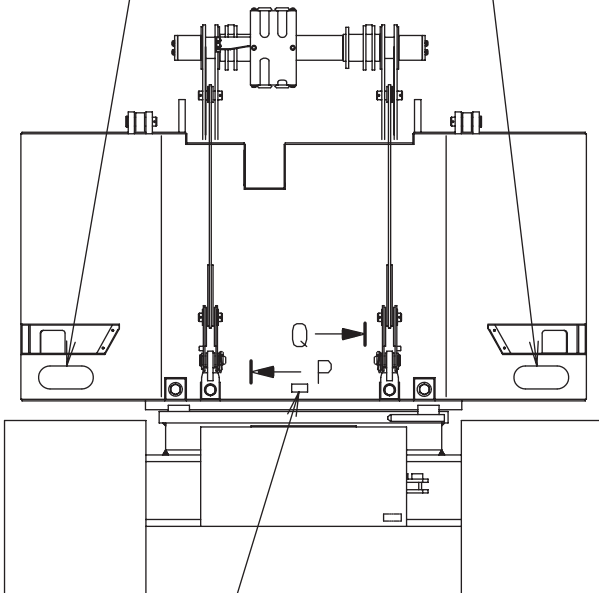

⚠ CAUTION

Stay out from crane swing area.

JJ20T01095P1

JJ20T01095P1

TENSION BAR CONNECTIONS

WITHOUT COUNTERWEIGHT WITH COUNTERWEIGHT

TRAVEL KITS (OPT.)

GG20T01125P1

GG20T01125P1

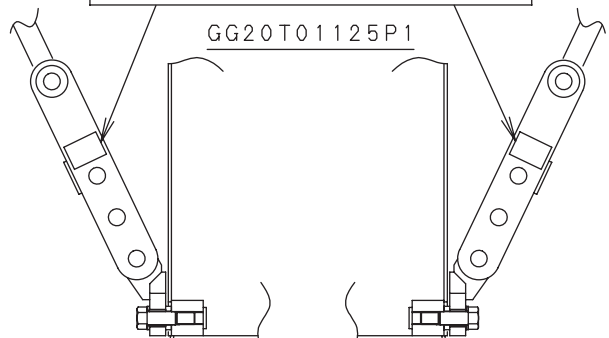

VIEW P

VIEW Q

	⚠ WARNING
	<p>AVOID ACID BURNS</p> <ul style="list-style-type: none"> · Electrolyte is an acid and can cause injury or blindness if it contacts skin or eyes. · Wear eye protection and protective clothing when handling or servicing batteries. · If electrolyte contacts skin or eyes, flush affected areas immediately with clean water and seek medical attention immediately. <p style="text-align: right; font-size: small;">YN20T01017P1</p>

YN20T01017P1

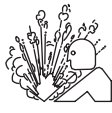
	⚠ WARNING
	<p>PREVENT BATTERY EXPLOSION</p> <ul style="list-style-type: none"> · Batteries give off hydrogen gases that can explode and cause personal injury. · Keep sparks, open flames and cigarettes away from batteries. · Keep metallic articles away from batteries. · Keep all ventilation caps tightly secured. · Never check charge by placing metal articles across battery terminals. · Leave battery box open to improve ventilation when charging. <p style="text-align: right; font-size: small;">YN20T01001P1</p>

YN20T01001P1

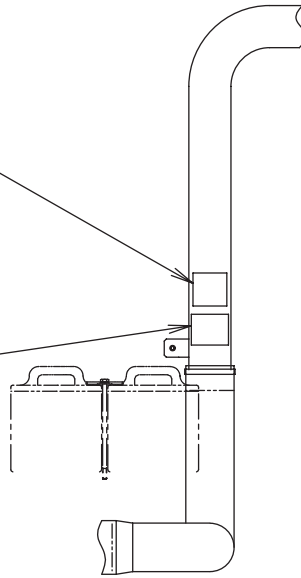

DETAIL R

<p>FUEL TANK</p>
⚠ CAUTION
<p>USE DIESEL FUEL ONLY</p> <p style="text-align: right; font-size: small;">FP20T01050P1</p>

FP20T01050P1

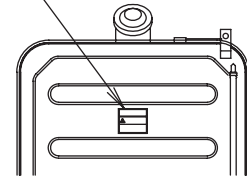

FUEL TANK

⚠ DANGER
<p>CRANE WORK SHOULD BE EXERCISED ON 'NEUTRAL BRAKE MODE'. OPERATIONS ON 'FREE FALL MODE' MAY CAUSE FALLING OF LOADS DUE TO OPERATIONAL ERROR.</p> <p style="text-align: right; font-size: small;">FP20T01045P1</p>

FP20T01045P1

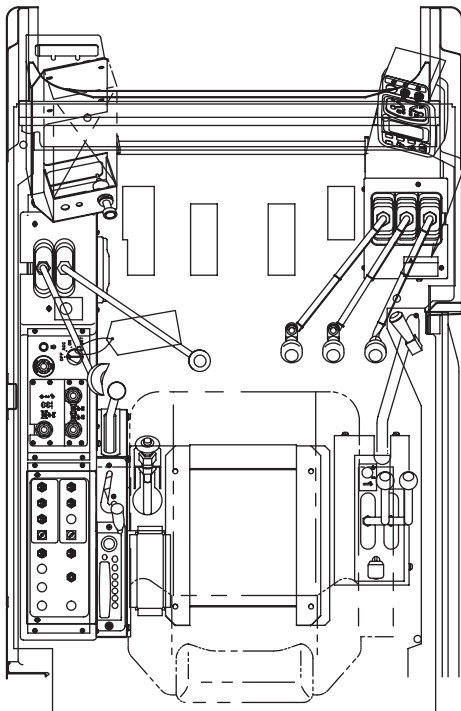

SECTION U-U

<p>HYDRAULIC TANK</p>
⚠ CAUTION
<p>HIGH TEMPERATURE DO NOT TOUCH</p> <p style="text-align: right; font-size: small;">FP20T01049P1</p>

FP20T01049P1

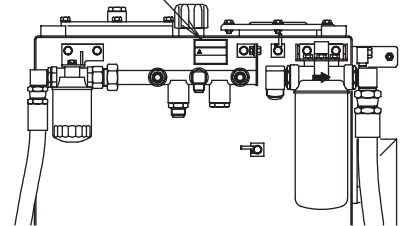

VIEW S
(HYD. OIL TANK)

⚠ DANGER
AVOID TIPPING OVER
WHEN CRAWLERS ARE RETRACTED
 MACHINES ON RETRACTED CRAWLERS HAVE LESS STABILITY AND MAY CAUSE TIPPING OVER WHEN SWINGED TO SIDES. OPERATE ONLY ON CONDITIONS NOTED ON OPERATORS MANUAL.



FP20T01048P1

FP20T01048P1

⚠ CAUTION
READ BEFORE OPERATION
 OPERATORS MANUAL SHOULD BE READ AND UNDERSTOOD BEFORE OPERATION. DAILY MAINTENANCE SHOULD ALWAYS BE EXERCISED. ALSO, CAUTIONS NOTED IN RATING PLATES MUST BE OBSERVED DURING OPERATION.

FP20T01047P1

FP20T01047P1

⚠ DANGER
DO NOT LIFT WITH CRAWLERS RETRACTED
 EXTEND CRAWLERS TO PROPER POSITION WHEN LIFTING. FAILURE TO DO SO MAY CAUSE TIPPING OVER. DUE TO LACK OF STABILITY.

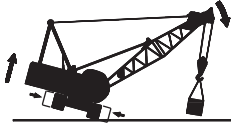

GB20T01197P1

GB20T01197P1

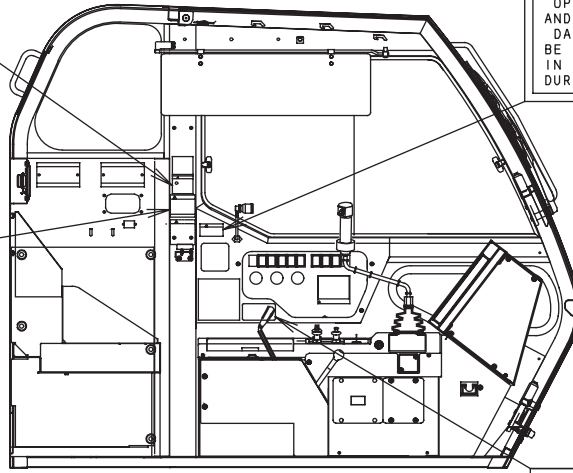

INSIDE VIEW (L/H)

⚠ CAUTION
 WHEN LOCKING THE BRAKE PEDAL, STEP ON THE PEDAL FULLY TO LOCK THE PAWL AT THE BOTTOM NOTCH.

2432T5113

2432T5113

⚠ CAUTION
 THIS MACHINE CONTAINS ALLOY AND HEAT TREATED STEELS. DO NOT WELD OR APPLY HEAT WITHOUT CHECKING WITH YOUR AUTHORIZED DEALER. UNAUTHORIZED MODIFICATIONS MAY WEAKEN THE MACHINE.

2432T4671

2432T4671

⚠ DANGER

DEATH OR INJURY MAY RESULT IF MACHINE, LOAD, OR LOAD LINE TOUCHES OR COMES CLOSE TO ELECTRICAL LINES. ALWAYS MAINTAIN A CLEARANCE OF AT LEAST 10 FEET (3 METERS) BETWEEN THE CRANE OR THE LOAD BEING HANDLED AND POWERLINES.

UNLAWFUL TO PLACE ANY PART OF THIS MACHINE OR LOAD WITHIN 10 FEET (3 METERS) OF HIGH VOLTAGE LINES OF 50,000 VOLTS OR LESS. GREATER CLEARANCES ARE REQUIRED FOR HIGHER VOLTAGES. SEE YOUR LOCAL, STATE, AND FEDERAL REGULATIONS.

ALWAYS NOTIFY ELECTRIC COMPANY IF THERE ARE ELECTRIC LINES IN THE AREA WHERE MACHINE WILL BE WORKING.

GG20T01127P1

GG20T01127P1

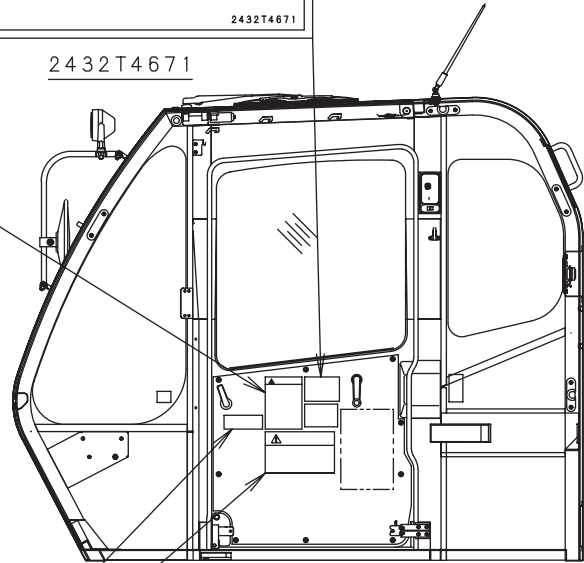

INSIDE VIEW (R/H)

⚠ CAUTION
 DO NOT LIFT PEOPLE WITH THIS CRANE. FAILURE TO DO SO MAY CAUSE SERIOUS INJURY.

2432T4668

2432T4668

⚠ DANGER
STAY AWAY FROM MACHINE IF CLOSE TO POWER LINES. MACHINE, LOAD AND GROUND MAY BECOME ELECTRIFIED AND DEADLY.

GG20T01128P1

GG20T01128P1

SAFETY

CAUTION

STRUCTURAL FAILURE

Gantry must be in high position
Read operators manual for boom connecting length

BOOM TOP ONLY

40ft and shorter

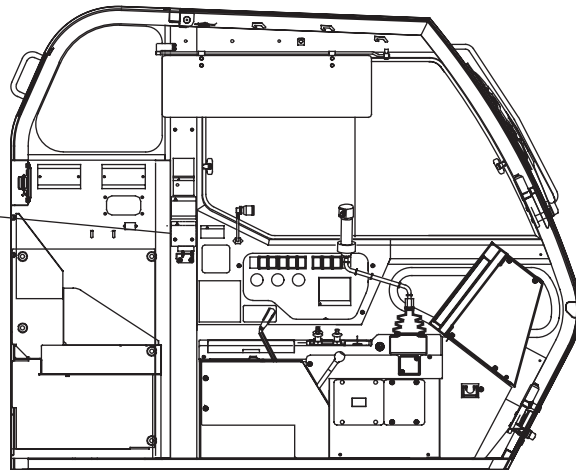

CAUTION

MOVING PARTS CAN CUT AND CRUSH
STRUCTURAL DAMAGE

Place guides in storing position after connecting spreader to boom.
At first the guides should be held by hands and pins disengaged, and then should be placed in storing position.

STORING POSITION

WORKING POSITION (BOOM DISASSEMBLING / ASSEMBLING)

GUIDE CLEARANCE

PIN "A"

DISASSEMBLING OF PIN "A"

FP20T01124P1

FP20T01124P1

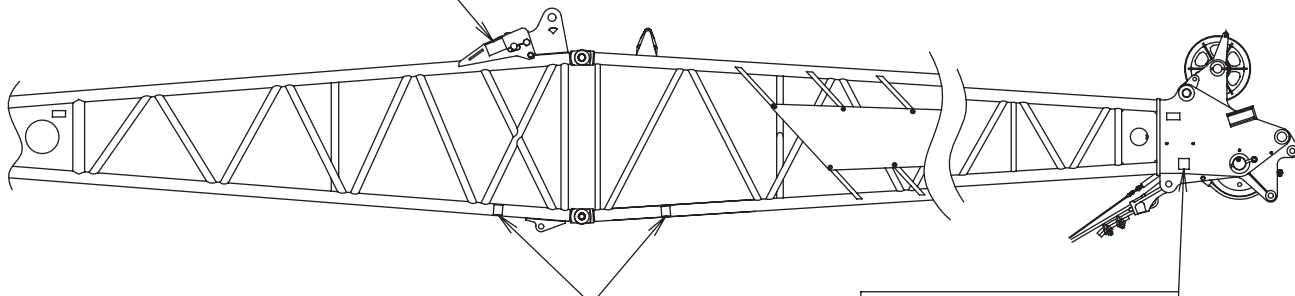

DANGER

DO NOT ENTER UNDER BOOM

TO AVOID SERIOUS INJURY CAUSED BY FALLING OF BOOM. DO NOT ENTER UNDER BOOM WHILE DISASSEMBLING / ASSEMBLING OF BOOM.

FP20T01013P1

FP20T01013P1

CAUTION

Boom top

Boom foot

Boom top

Boom foot

CORRECT

WRONG

GG20T01561P1

Install the rope socket in the correct direction. Otherwise, the rope socket or the wire rope may interfere with the boom, causing damage to the boom or cut of the wire rope.

GG20T01561P1