

# OPERATION & MAINTENANCE MANUAL

CK1600  
(LUFFING)

APPLICABLE : from GN03-02001

BOOK CODE : S2GN10002ZE08

(C) Printed in Japan 2007.03



**IMPORTANT INFORMATION**

**1. SAFE OPERATING PRACTICES FOR MOBILE CRANES**

**2. OPERATION**

2.1 TERMINOLOGY OF MACHINE EACH PART ..... 2-1

    2.1.1 LUFFING UPPER BOOM ATTACHMENT ..... 2-1

    2.1.2 LUFFING JIB ATTACHMENT ..... 2-2

2.2 LOCATIONS AND TERMS OF OPERATING CONTROLS ..... 2-3

    2.2.1 OPERATING SWITCHES..... 2-7

    2.2.2 GAUGE CLUSTER CONFIGURATION ..... 2-17

    2.2.3 OPERATING THE AIR CONDITIONER ..... 2-31

    2.2.4 AM/FM RADIO (OPTION)..... 2-33

2.3 CRANE OPERATION ..... 2-35

    2.3.1 ADJUSTING THE OPERATOR'S SEAT..... 2-35

    2.3.2 ADJUSTING THE CONTROL LEVER DIRECTION ..... 2-35

    2.3.3 STARTING AND STOPPING THE ENGINE ..... 2-36

    2.3.4 FUNCTION LOCK LEVER..... 2-39

    2.3.5 PROPELLING OPERATION..... 2-40

    2.3.6 SWINGING OPERATION ..... 2-42

    2.3.7 BOOM RAISING/LOWERING OPERATION ..... 2-45

    2.3.8 HOOK RAISING/LOWERING OPERATION..... 2-47

2.4 LUFFING JIB OPERATION ..... 2-50

    2.4.1 JIB RAISING/LOWERING OPERATION ..... 2-51

    2.4.2 HOOK HOIST DRUM CONTROL..... 2-53

2.5 FREE FALL OPERATION ..... 2-54

2.6 HANDLING OF REEVING WINCH (OPTION) ..... 2-57

**3. LOAD SAFETY DEVICE**

3.1 ARRANGEMENT OF EQUIPMENTS ..... 3-1

3.2 TYPE AND FUNCTIONS OF EQUIPMENTS ..... 3-5

3.3 CONNECTING PROCEDURE OF WIRING ..... 3-13

    3.3.1 CRANE ATTACHMENT..... 3-13

    3.3.2 LUFFING ATTACHMENT ..... 3-17

3.4 FUNCTION OF CONTROLLER/MONITOR ..... 3-22

3.5 OPERATING PROCEDURE OF CONTROLLER..... 3-26

    3.5.1 SETTING SCREEN ..... 3-27

    3.5.2 SETTING OF THE CRANE CONFIGURATION ..... 3-32

    3.5.3 SELECTION OF MAIN/JIB/AUX. LIFTING ..... 3-37

## TABLE OF CONTENTS

---

3.5.4	SETTING OF WORKING AREA LIMIT VALUE.....	3-38
3.5.5	SETTING OF THE TIME .....	3-42
3.6	WARNING ALARM AND AUTOMATIC STOP .....	3-44
3.6.1	ITEMS OF WARNING ALARM AND AUTOMATIC STOP .....	3-44
3.6.2	CONTENTS OF AUTOMATIC STOP .....	3-46
3.6.3	RELEASE OF AUTOMATIC STOP .....	3-50
3.7	INSPECTION .....	3-56
3.7.1	INSPECTION BEFORE RAISING THE BOOM AFTER ASSEMBLY OF ATTACHMENT IS COMPLETED .....	3-56
3.7.2	INSPECTION AFTER ERECTING THE ATTACHMENT .....	3-62
3.8	CAUTION FOR HANDLING THE LOAD SAFETY DEVICE.....	3-63
3.9	INDICATION OF ERRORS AND REMEDY .....	3-64
3.10	INDICATION OF MESSAGE AND ALARM.....	3-65
3.11	CONFIRMATION OF FUNCTION FOR LOAD SAFETY DEVICE .....	3-67

## 4. ASSEMBLY OF THE MACHINE

4.1	STABILITY IN SWINGING AND TRAVELING .....	4-1
4.1.1	WITHOUT BOOM BASE .....	4-1
4.1.2	WITH BOOM BASE.....	4-3
4.2	TRANSLIFTER.....	4-4
4.2.1	COMPOSITION OF TRANSLIFTER .....	4-4
4.2.2	HANDLING TRANSLIFTERS (1) - (4).....	4-5
4.3	UNLOADING BASE MACHINE.....	4-8
4.3.1	ERECTING GANTRY .....	4-9
4.3.2	SETTING TRANSLIFTERS .....	4-11
4.3.3	UNLOADING BASE MACHINE FROM TRAILER .....	4-15
4.4	INSTALLATION OF THE CARBODY WEIGHT (OPTION) .....	4-17
4.5	INSTALLATION OF CRAWLER.....	4-19
4.5.1	INSTALLATION OF THE FIRST CRAWLER .....	4-19
4.5.2	INSTALLATION OF THE SECOND CRAWLER .....	4-23
4.6	INSTALLATION OF THE COUNTERWEIGHT .....	4-25
4.6.1	ASSEMBLING THE COUNTERWEIGHTS .....	4-25
4.6.2	REMOVING THE HOOK BLOCK FROM THE BASE BOOM.....	4-29
4.6.3	SETTING THE COUNTER-WEIGHT LINK .....	4-29
4.6.4	INSTALLATION OF COUNTERWEIGHTS TO MACHINE.....	4-30
4.7	ASSEMBLING CRANE WITH LUFFING BOOM TIP ATTACHMENTS .....	4-35
4.7.1	ASSEMBLY OF BOOM/GUY LINE .....	4-35
4.7.2	ASSEMBLING OF BOOM/GUY LINE (Using an assisting crane).....	4-41

## TABLE OF CONTENTS

---

4.7.3	ASSEMBLING OF BOOM/GUY LINE (Self-erection with boom base on the base machine).....	4-49
4.7.4	INSTALLATION OF AUXILIARY SHEAVE.....	4-54
4.7.5	REEVING FRONT DRUM WIRE ROPE FOR CRANE.....	4-55
4.7.6	REEVING REAR DRUM WIRE ROPE TO AUXILIARY SHEAVE.....	4-57
4.8	ASSEMBLING THE LUFFING ATTACHMENTS.....	4-58
4.8.1	ARRANGEMENT OF BOOM/JIB/GUY LINE.....	4-58
4.8.2	ASSEMBLING OF BOOM/JIB/GUY LINE (Using an assisting crane).....	4-63
4.8.3	ASSEMBLING OF BOOM/JIB/GUY LINE (Self-election with boom base on the base machine).....	4-77
4.8.4	REEVING FRONT DRUM WIRE ROPE FOR CRANE.....	4-91
4.9	ERECTING ATTACHMENT.....	4-94
4.9.1	CONNECTING SAFETY DEVICE.....	4-94
4.9.2	CHECKING SAFETY DEVICE.....	4-94
4.9.3	CONFIRMATION BEFORE ERECTING ATTACHMENT.....	4-94
4.9.4	ERECTING THE CRANE ATTACHMENT.....	4-95
4.9.5	CHECK BEFORE STARTING WORK.....	4-96
4.9.6	ERECTING THE LUFFING ATTACHMENT.....	4-97
4.9.7	CHECK BEFORE STARTING THE WORK.....	4-101

## 5. DISASSEMBLY OF THE MACHINE

5.1	LOWERING THE ATTACHMENT.....	5-3
5.1.1	LOWERING THE ATTACHMENT.....	5-3
5.2	LOWERING THE LUFFING ATTACHMENT.....	5-4
5.2.1	LOWERING THE ATTACHMENT.....	5-5
5.3	WINDING UP THE FRONT DRUM/REAR DRUM WIRE ROPES.....	5-8
5.4	DISCONNECTING THE WIRING FOR SAFETY DEVICE.....	5-8
5.5	WINDING UP THE JIB DRUM WIRE ROPE.....	5-9
5.6	REMOVING BOOM GUY LINE.....	5-9
5.6.1	INSTALLATION OF UPPER SPREADER TO BOOM BASE.....	5-9
5.6.2	DISCONNECT BOOM BASE FROM INSERT BOOM.....	5-9
5.7	COUNTERWEIGHT REMOVAL.....	5-11
5.7.1	REMOVAL OF COUNTERWEIGHTS.....	5-11
5.7.2	INSTALLATION OF THE HOOK BLOCK TO THE BOOM BASE.....	5-16
5.7.3	DISASSEMBLY OF THE COUNTERWEIGHT.....	5-16
5.8	DISASSEMBLING CRANE WITH LUFFING BOOM TIP ATTACHMENT.....	5-18
5.8.1	REMOVING THE AUXILIARY SHEAVE.....	5-18
5.8.2	REMOVAL OF BOOM GUY LINE.....	5-18
5.8.3	REMOVING UPPER AND INSERT BOOMS.....	5-19

## TABLE OF CONTENTS

---

5.9	DISASSEMBLY OF LUFFING ATTACHMENT .....	5-20
5.9.1	DISASSEMBLING THE LUFFING JIB .....	5-20
5.9.2	DISASSEMBLING THE LUFFING BOOM TIP ASSEMBLY.....	5-21
5.10	REMOVAL OF THE CRAWLERS .....	5-22
5.10.1	SETTING THE TRANSLIFTER .....	5-22
5.10.2	REMOVAL OF THE CRAWLERS .....	5-23
5.11	REMOVAL OF THE CARBODY WEIGHTS (OPTION).....	5-29
5.12	LOADING THE BASE MACHINE.....	5-30
5.12.1	LOADING THE BASE MACHINE ON THE TRAILER .....	5-30
5.12.2	LOWERING THE BOOM BASE .....	5-32
5.12.3	LOWERING THE GANTRY .....	5-33
5.12.4	FOLDING THE TRANSLIFTER.....	5-34
5.12.5	CAUTION WHEN TRANSPORTING THE BASE MACHINE .....	5-35
5.12.6	HANDLING OF TRAVELING KIT (OPTION).....	5-36
5.13	LOWERING THE ATTACHMENT (JIB INSIDE HOLDING STYLE).....	5-37
<b>6.</b>	<b>WIRE ROPE</b>	
6.1	HANDLING OF WIRE ROPE .....	6-1
6.1.1	UNREELING METHOD OF WIRE ROPE .....	6-1
6.1.2	WINDING WIRE ROPE ONTO THE DRUM.....	6-2
6.1.3	INSTALLING THE ROPE SOCKET .....	6-4
6.1.4	SPECIFICATION OF WIRE ROPE .....	6-4
6.1.5	WIRE ROPE LENGTH .....	6-5
<b>7.</b>	<b>MAINTENANCE</b>	
7.1	CHECKS .....	7-6
7.1.1	CHECKS OF THE UPPER.....	7-7
7.1.1.1	UPPER STRUCTURE INSPECTIONS-DAILY OR EVERY 8 HOURS.....	7-8
7.1.1.2	UPPER STRUCTURE INSPECTIONS-MONTHLY OR EVERY 100 HOURS.....	7-13
7.1.1.3	CHECK OF UPPER SEMI-ANNUALLY OR EVERY 600 HOURS .....	7-17
7.1.1.4	CHECK OF UPPER WEEKLY OR EVERY 50 HOURS .....	7-18
7.1.2	CHECK OF LOWER.....	7-20
7.1.2.1	CHECK OF LOWER DAILY OR EVERY 8 HOURS .....	7-22
7.1.2.2	CHECK OF LOWER MONTHLY OR EVERY 100 HOURS .....	7-23
7.1.2.3	CHECK OF LOWER QUARTERLY EVERY 3 MONTHS OR EVERY 250 HOURS.....	7-25
7.1.2.4	CHECK OF LOWER SEMI-ANNUALLY OR EVERY 600 HOURS .....	7-25
7.1.3	CHECK OF ATTACHMENT .....	7-26
7.1.3.1	CHECK OF ATTACHMENT DAILY OR EVERY 5 HOURS.....	7-28
7.2	OIL/GREASE SUPPLY AND WATER SERVICE .....	7-36
7.2.1	UPPER LUBRICATION (INCL. WATER SUPPLY).....	7-40

## TABLE OF CONTENTS

---

7.2.2	LOWER LUBRICATION .....	7-42
7.2.3	ATTACHMENT LUBRICATION .....	7-44
7.2.4	GREASE .....	7-46
7.2.5	ENGINE OIL .....	7-52
7.2.6	FUEL .....	7-53
7.2.7	COOLANT .....	7-54
7.2.8	HYDRAULIC OIL .....	7-56
7.2.9	GEAR OIL .....	7-58
7.3	CLEANING/WASHING/CHANGING FILTER ELEMENT AND STRAINER .....	7-64
7.4	BATTERY INSPECTION .....	7-75
7.5	LOCATION AND USE OF FUSE .....	7-78
7.6	OPERATION UNDER UNUSUAL CONDITIONS .....	7-80
7.7	MACHINE STORAGE .....	7-82
7.8	TIGHTENING TORQUE VALUES .....	7-83
7.9	SECURITY PARTS TO BE REPLACED PERIODICALLY .....	7-85
7.10	ADJUSTMENT .....	7-86
7.10.1	ADJUSTMENT OF FRONT AND REAR DRUM LOCKS .....	7-86
7.10.2	ADJUSTMENT OF BOOM DRUM LOCK .....	7-87
7.10.3	ADJUSTMENT OF THIRD DRUM LOCK .....	7-88
7.10.4	CRAWLER SHOES ADJUSTMENT .....	7-89
7.11	CONSUMABLE PARTS LIST .....	7-90

## 8. REFERENCE MATERIALS

8.1	SPECIFICATION .....	8-1
8.1.1	PERFORMANCE .....	8-1
8.1.2	PERFORMANCE OF LUFFING JIB .....	8-1
8.1.3	OUTSIDE DIMENSIONS .....	8-2
8.2	DIMENSIONS AND WEIGHT OF EACH PARTS .....	8-5
8.2.1	BASE MACHINE .....	8-5
8.2.2	COUNTERWEIGHT .....	8-7
8.2.3	ATTACHMENT .....	8-8
8.3	SYSTEM SCHEMATIC .....	8-12
8.3.1	HYDRAULIC SCHEMATIC .....	8-12
8.3.2	ELECTRIC SYSTEM SCHEMATIC .....	8-14

## 9. INITIAL ASSEMBLY OF THE MACHINE

9.1	UPPER STRUCTURE (WITH CARBODY) LIFTING PROCEDURES .....	9-2
9.1.1	INSTALLATION .....	9-2
9.2	LOADING/UNLOADING OF THE MACHINE FROM/ONTO A TRAILER .....	9-3

## TABLE OF CONTENTS

---

9.2.1	LOADING ONTO A TRAILER .....	9-3
9.2.2	UNLOADING FROM A TRAILER .....	9-3
9.3	INSTALLATION OF THE CARBODY WEIGHT (OPTION) .....	9-7
9.4	INSTALLATION OF THE CRAWLER.....	9-8
9.4.1	INSTALLATION OF THE FIRST CRAWLER .....	9-8
9.4.2	INSTALLATION OF THE SECOND CRAWLER .....	9-12
9.5	INSTALLATION OF THE GANTRY TO THE SWING FRAME.....	9-13
9.6	INSTALLATION OF THE BOOM BASE .....	9-17
9.6.1	INSTALLATION OF THE BOOM BASE .....	9-17
9.7	INSTALLATION OF THE BACKSTOP .....	9-18
9.8	INSTALLING THE UPPER AND LOWER SPREADER .....	9-19



## **IMPORTANT INFORMATION**

Thank you for your purchasing KOBELCO crawler crane. Our CK series full-hydraulically operated crawler crane is manufactured based on our long years of experience and expertise. This manual describes the important information about Model CK1600.

Before operating the machine, be sure to thoroughly read this manual to use the machine safely and efficiently.

---



**Do not operate or maintain this machine until you read this manual and understand the instructions. Improper operation or maintenance of this machine may cause accidents and could result in serious injury or death.**

**Always keep this manual in the operators cab.**

**If it is missing or damaged, place an order to a KOBELCO authorize distributor for a replacement.**

**If you have any questions, please consult your KOBELCO authorize distributor.**

---

### **SAFETY INFORMATION**

Most accidents, which occur during operation, are due to neglect of precautionary measures and safety rules. Sufficient care should be taken to avoid these accidents.

Erroneous operation, lubrication or maintenance services are very dangerous and may cause injury or death of personnel.

Thus, precautionary measures, or notes, written in this manual should be read and understood by personnel before starting each task.

Operation, inspection, and maintenance should be carefully carried out, and safety must be given the first priority.

Messages of safety are indicated with  marks. The safety information contained in this manual is intended only general safety information.

Messages of safety appear in this manual and on the machine. All messages of safety are identified by the words "DANGER", "WARNING" and "CAUTION". These words mean the following:



Indicates an imminently hazardous situation which, if not avoided, will result in death or serious injury.



Indicates a potentially hazardous situation which, if not avoided, could result in death or serious injury.



Indicates a potentially hazardous situation which, if not avoided, may result in minor or moderate injury. It may also be used to alert against possible damage to the machine and its components.

**Note**

Supplementary explanation.

It is very difficult for us to forecast every danger that may occur during operation. However, safety can be ensured by operating this machine according to methods recommended by KOBELCO. While operating machine, be sure to perform work with great care, so as to not damage the machine, or let accidents occur.

Please continue studying this manual until proper operation is completely understood.

# IMPORTANT INFORMATION

## MACHINE SERIAL NUMBER

When you order repair parts and when you need repair or service of the machine, always inform us the machine serial number stamped on the name plate and the total number of hours indicated on the hourmeter which is located in the gauge.

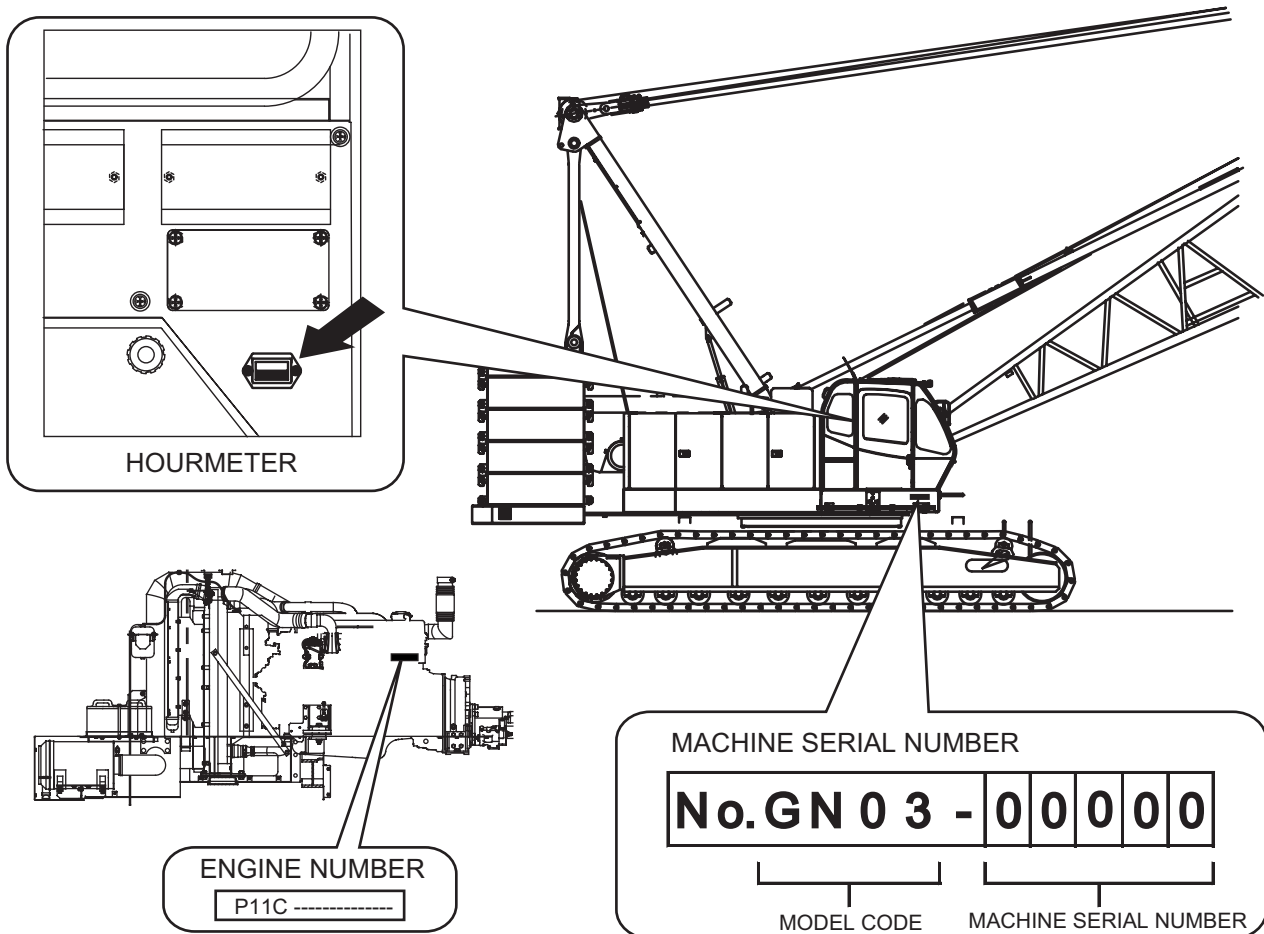

## ENTER MACHINE SERIAL NUMBER OF THIS MACHINE

MACHINE MODEL	CK1600	MACHINE SERIAL No.	GN03-	ENGINE No.	P11C-
---------------	--------	--------------------	-------	------------	-------

## WARRANTY

The terms under which this machine is guaranteed are clearly defined in the accompanying WARRANTY. Trouble and damage occurred during the terms of guarantee shall be repaired at no cost to the purchaser according to the warrant description if the trouble or damage is recognized to be our responsibility. However, if you use the machine contrary to the instructions of this manual, the WARRANTY does not cover any damage to the machine.

## REPAIR PARTS

When servicing and repairing the machine, be sure to use genuine parts in order to make the machine performance display sufficiently. Since the important security parts are prepared to ensure safety and to protect the machine from an serious accident, be sure to replace them every specified period of time.

### **EXPLANATION OF WARNING LABELS**

Since the warning labels are installed in the machine and indicated with the three stages in the same way as the warning description, confirm the positions and contents of all warning labels first. Put them to the practical use to secure safety when operating, checking and performing maintenance.

### **HANDLING OF WARNING LABELS**

1. When the warning label is damaged or stained, order it to the designated service shop.
2. Do not remove the warning labels.
3. When the surface of the warning label is soiled and difficult to be seen, wipe it cleanly.

# IMPORTANT INFORMATION

**CAUTION**  
Moving parts.  
JJ20T01096P1

**CAUTION**  
Only to open when machine is stopped.  
JJ20T01100P1

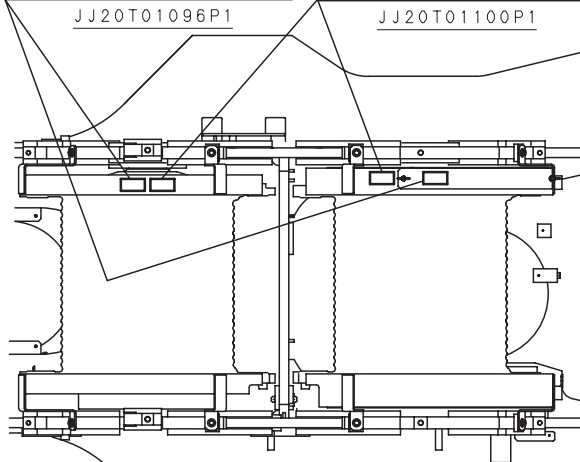

VIEW B

**DANGER**

DEATH OR INJURY MAY RESULT IF MACHINE, LOAD, OR LOAD LINE TOUCHES OR COMES CLOSE TO ELECTRICAL LINES. ALWAYS MAINTAIN A CLEARANCE OF AT LEAST 10 FEET (3 METERS) BETWEEN THE CRANE OR THE LOAD BEING HANDLED AND POWERLINES.

UNLAWFUL TO PLACE ANY PART OF THIS MACHINE OR LOAD WITHIN 10 FEET (3 METERS) OF HIGH VOLTAGE LINES OF 50,000 VOLTS OR LESS. GREATER CLEARANCES ARE REQUIRED FOR HIGHER VOLTAGES. SEE YOUR LOCAL, STATE, AND FEDERAL REGULATIONS.

ALWAYS NOTIFY ELECTRIC COMPANY IF THERE ARE ELECTRIC LINES IN THE AREA WHERE MACHINE WILL BE WORKING.

GG20T01127P1

GG20T01127P1

**DANGER**  
When lock pin is not installed, do not stand under gantry.  
JJ20T01097P1

JJ20T01097P1

**DANGER**

**STAY AWAY FROM MACHINE IF CLOSE TO POWER LINES. MACHINE, LOAD AND GROUND MAY BECOME ELECTRIFIED AND DEADLY.**

GG20T01128P1

GG20T01128P1

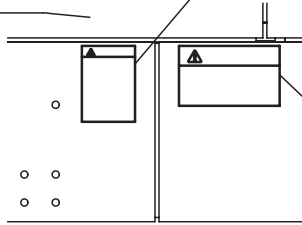

DETAIL e

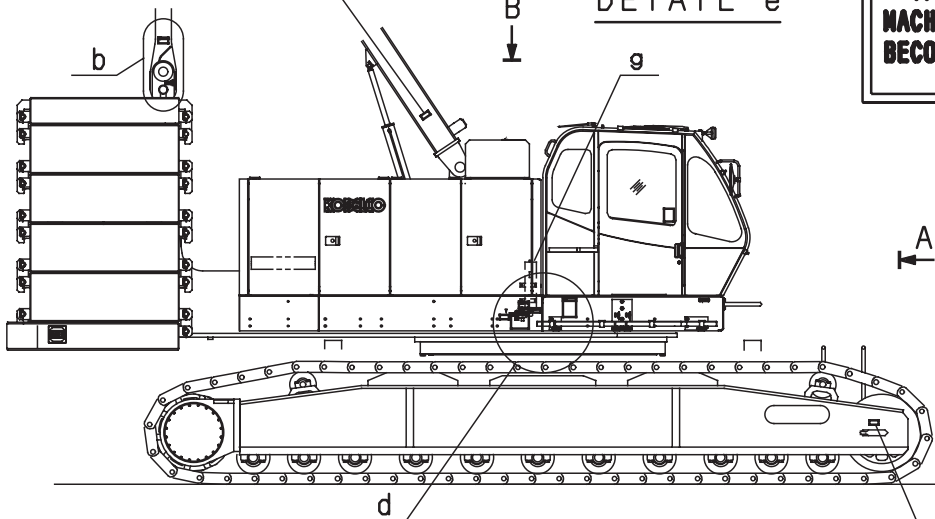

**DANGER**

NEVER FORGET TO ENGAGE GANTRY CONNECTION PINS TO AVOID FALLING OF BOOMS. GANTRY CONNECTION PINS MUST BE ENGAGED WHEN GANTRY IS AT HIGH POSITION. ALSO, LOWER PARTS OF TENSION BARS MUST BE CONNECTED TO REVOLVING FRAME OR COUNTERWEIGHT WHEN GANTRY IS AT LOW POSITION.

FP20T01046P1

FP20T01046P1

**CAUTION**  
Moving parts.  
JJ20T01096P1

JJ20T01096P1

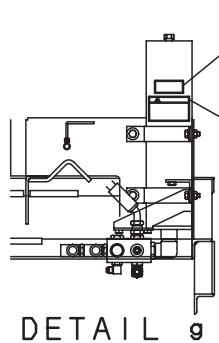

ACCUMULATOR  
CHARGING GAS PRESSURE.  
3.4~3.7Mpa  
(35~38 Kg/cm<sup>2</sup>)  
GG20T01079P1

GG20T01079P1

**WARNING**  
AVOID EXPLOSION WHEN HANDLING ACCUMULATOR  
THIS CASE IS CHARGED WITH HIGH PRESSURE NITROGEN GAS. NEVER ATTEMPT TO WELD, GAS-CUT, PUT ON FIRE, NOR DISASSEMBLE THE CASE TO AVOID EXPLOSION.  
FP20T01042P1

FP20T01042P1

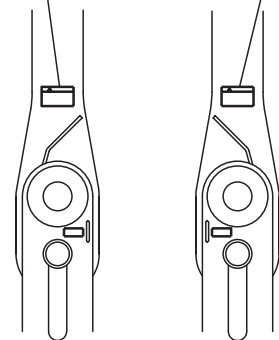

DETAIL b (R/H)      DETAIL c (L/H)

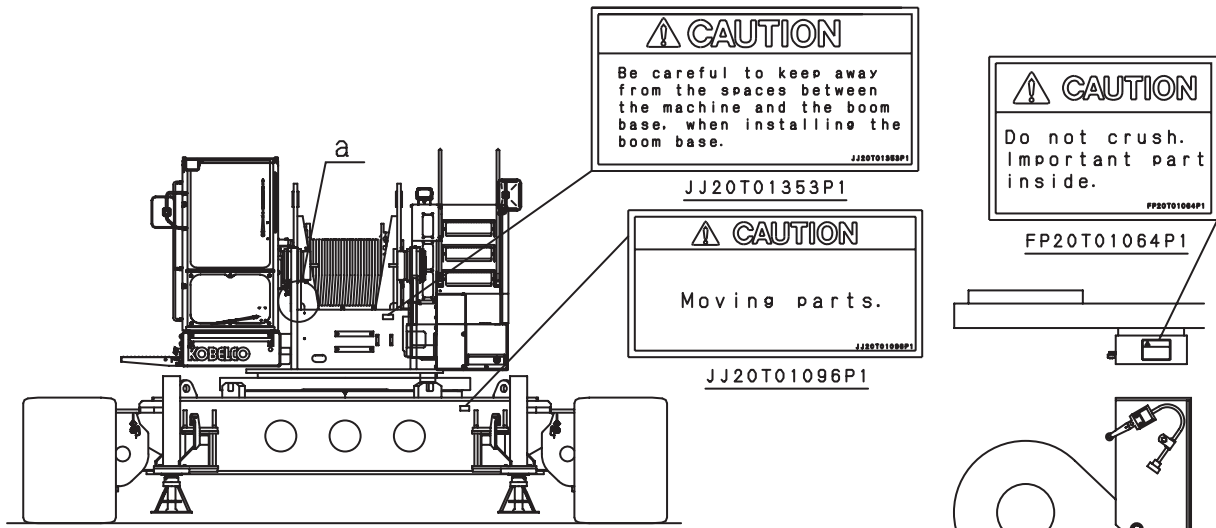

**DETAIL A**

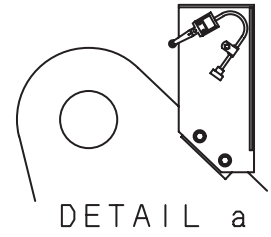

**DETAIL a**

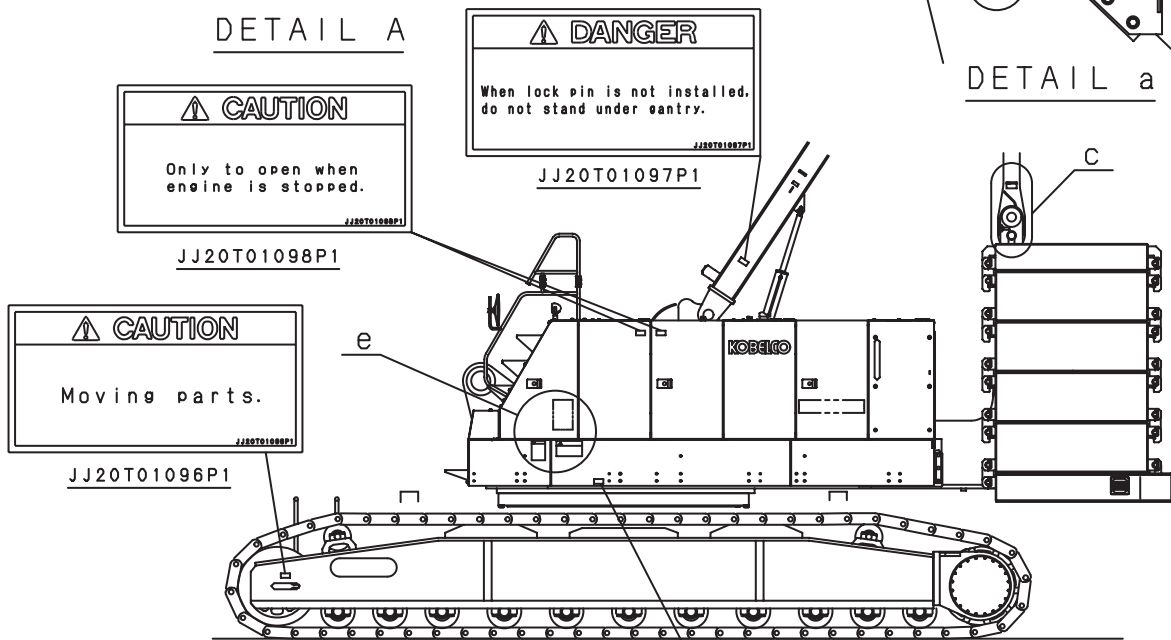

**⚠ DANGER**

**WHEN INSTALLATION AND REMOVAL OF THE CRAWLERS (1)**

- Do not stand under or near the crawlers being lifted.
- The lifter should be operated on the firm and level ground with the machine maintained horizontally.
- Steel plates may be needed under the floats unless the ground is concreted.

**⚠ WARNING**

**WHEN INSTALLATION AND REMOVAL OF THE CRAWLERS (2)**

- Do not insert spacers into pin holes for alignment.
- The quick couplers must be connected completely.

JJ20T01102P1

**⚠ CAUTION**

Stay out from crane swing area.

JJ20T01095P1

**⚠ CAUTION**

Stay out from crane swing area.

JJ20T01095P1

**⚠ DANGER**

ALL COUNTERWEIGHTS MUST BE REMOVED BEFORE OPERATING THE LIFTER.

GN20T01041P1

**⚠ DANGER**

DEATH OR INJURY MAY RESULT IF MACHINE, LOAD, OR LOAD LINE TOUCHES OR COMES CLOSE TO ELECTRICAL LINES. ALWAYS MAINTAIN A CLEARANCE OF AT LEAST 10 FEET (3 METERS) BETWEEN THE CRANE OR THE LOAD BEING HANDLED AND POWERLINES.

UNLAWFUL TO PLACE ANY PART OF THIS MACHINE OR LOAD WITHIN 10 FEET (3 METERS) OF HIGH VOLTAGE LINES OF 50,000 VOLTS OR LESS. GREATER CLEARANCES ARE REQUIRED FOR HIGHER VOLTAGES. SEE YOUR LOCAL, STATE, AND FEDERAL REGULATIONS.

ALWAYS NOTIFY ELECTRIC COMPANY IF THERE ARE ELECTRIC LINES IN THE AREA WHERE MACHINE WILL BE WORKING.

GG20T01127P1

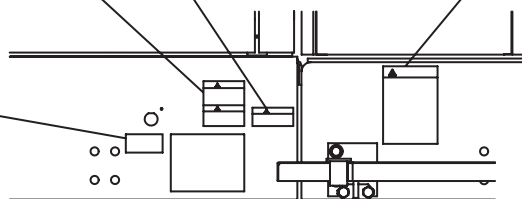

**DETAIL d**

# IMPORTANT INFORMATION

**WARNING**



WALKING ON GUARDS MAY CAUSE STUMBLING AT PROJECTED ITEMS AND SLIPPING BY OIL, WATER, OR GREASE.  
 PROTECTOR SHOULD BE EMPLOYED WHEN WALKING FOR MAINTENANCE JOB, TO AVOID TIPPING OVER AND FALLING DOWN FROM THE MACHINE.  
 FP20T01051P1

FP20T01051P1

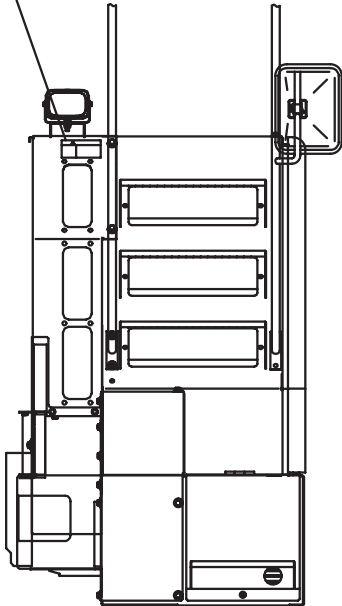

VIEW C

**WARNING**

Steam of hot coolant can cause injury or blindness.  
 Never loosen or open radiator cap when coolant is hot and under pressure.  
 Before opening radiator cap:  
 -Cool down engine completely.  
 -Cover radiator with cloth rag.  
 -Loosen cap slowly to relieve pressure.  
 YN20T01010P1

YN20T01010P1

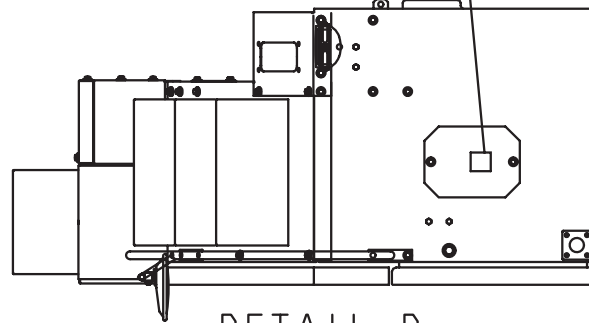

DETAIL D

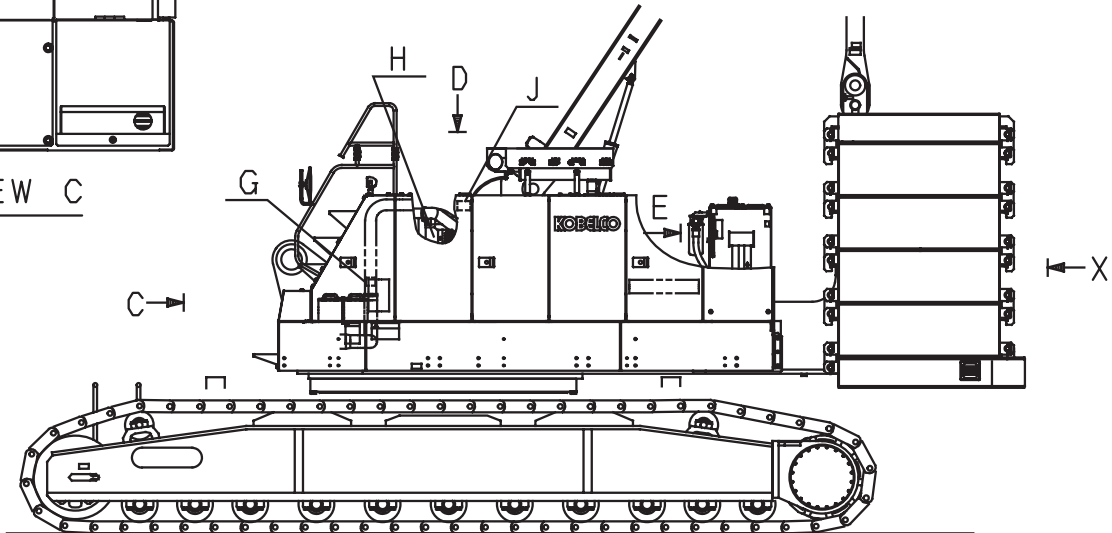

**WARNING**



Rotating parts can cause personal injury.  
 Keep away from fan and belt when engine is running.  
 Stop engine before servicing.  
 YN20T01009P1

YN20T01009P1

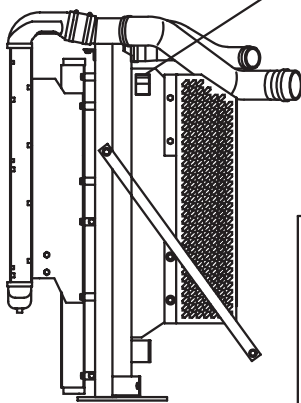

DETAIL H

**CAUTION**

**CAUTION FOR HIGH TEMPERATURE**

AS ENGINES AND MUFFLERS MAY BE HEATED TO HIGH TEMPERATURES, DO NOT DIRECTLY TOUCH THEM BY HAND.  
 FP20T01043P1

FP20T01043P1

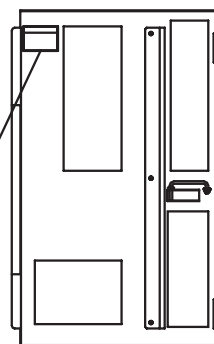

DETAIL J

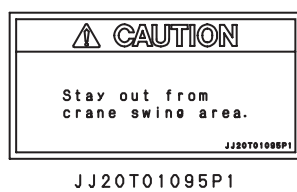
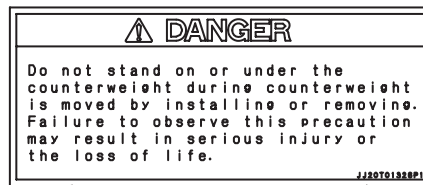
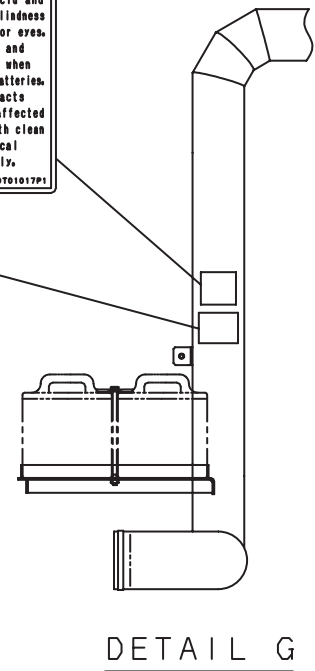
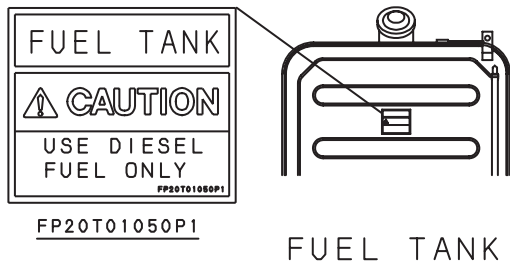
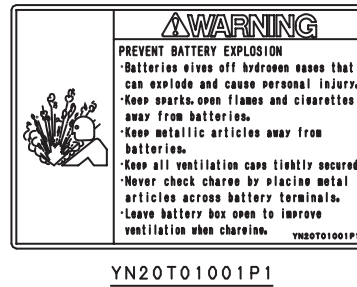
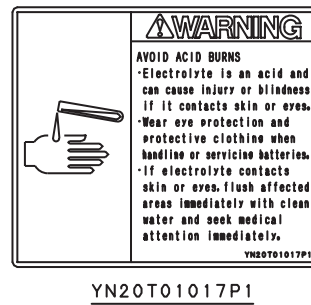
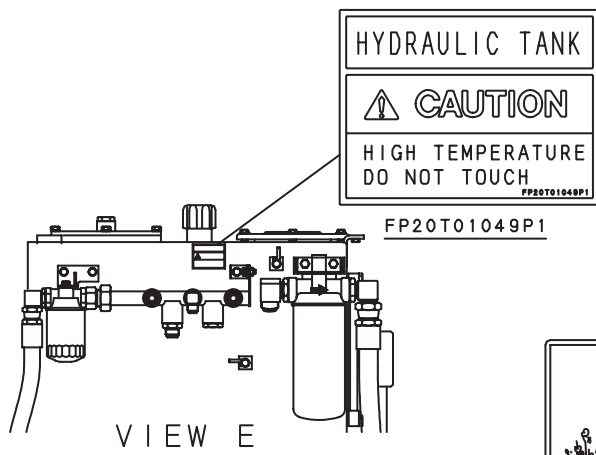

VIEW X

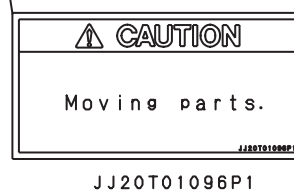

# IMPORTANT INFORMATION

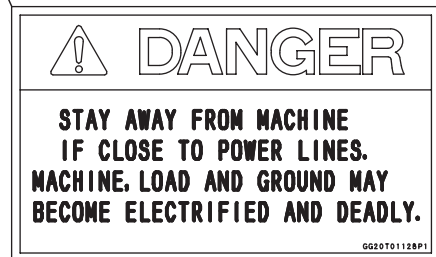
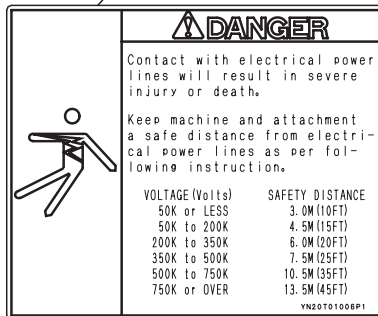
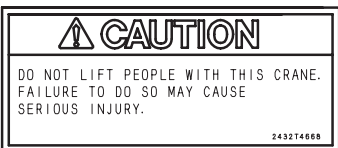
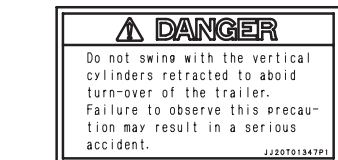
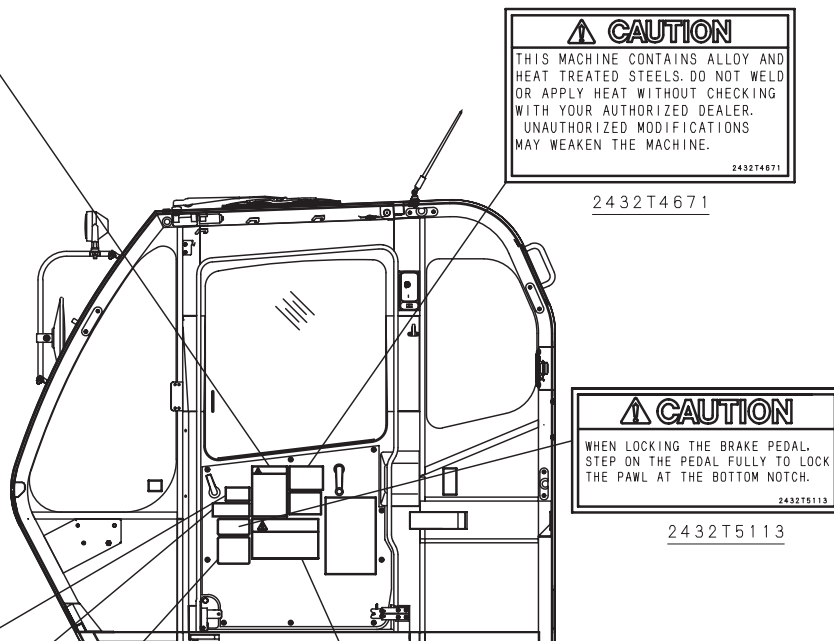
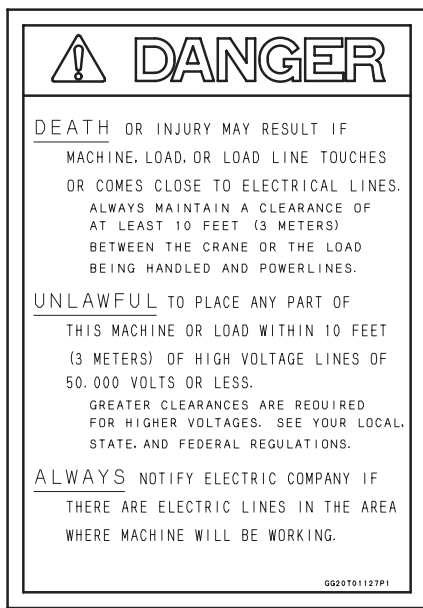
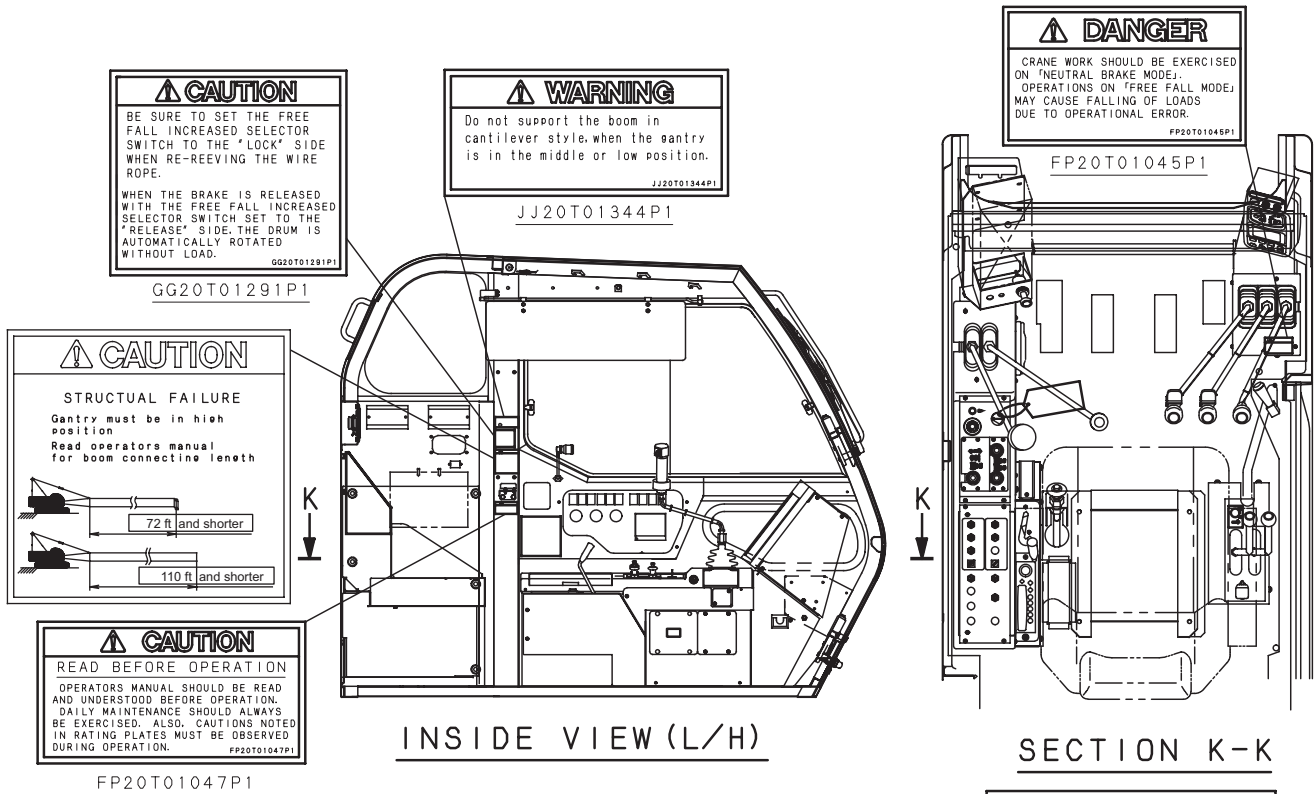

2432T4668

YN20T01006P1

GG20T01128P1



**CAUTION**

**CAUTION FOR USING SPREADER GUIDES**

TO AVOID DAMAGE TO SPREADER GUIDES, PLACE THE GUIDES TO STORING POSITION, AFTER SPREADER IS CONNECTED TO LOWER BOOM.

TO AVOID NIPPING OF HANDS OR FINGERS, AT FIRST THE GUIDES SHOULD BE HELD BY HANDS AND PINS DISENGAGED, AND THEN SHOULD BE PLACED IN STORING POSITION.

STORING POSITION      WORKING POSITION (BOOM DISASSEMBLING / ASSEMBLING)      DISASSEMBLING OF PIN "A"

FP20T01012P1

FP20T01012P1

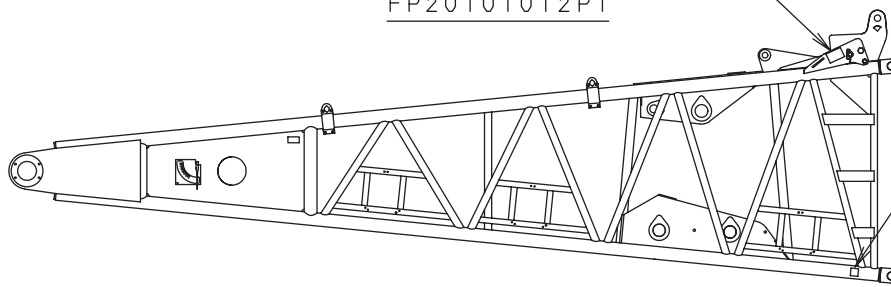

LOW BOOM

**DANGER**

**DO NOT ENTER UNDER BOOM**

TO AVOID SERIOUS INJURY CAUSED BY FALLING OF BOOM, DO NOT ENTER UNDER BOOM WHILE DISASSEMBLING / ASSEMBLING OF BOOM.

FP20T01013P1

FP20T01013P1

# IMPORTANT INFORMATION

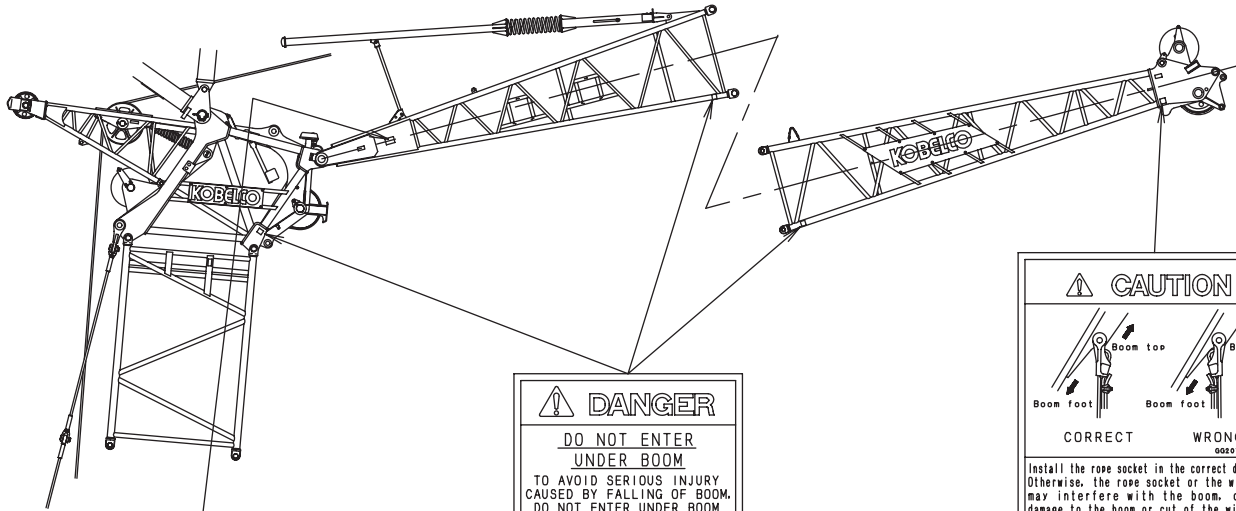

**CAUTION**

CORRECT      WRONG

GG20T01561P1

Install the rope socket in the correct direction. Otherwise, the rope socket or the wire rope may interfere with the boom, causing damage to the boom or cut of the wire rope.

GG20T01561P1

**DANGER**

**DO NOT ENTER UNDER BOOM**

TO AVOID SERIOUS INJURY CAUSED BY FALLING OF BOOM. DO NOT ENTER UNDER BOOM WHILE DISASSEMBLING/ASSEMBLING OF BOOM.

FP20T01013P1

FP20T01013P1

**CAUTION**

Be sure to place three (3) same height wooden blocks under the assembly, when transporting or laying on the ground. Failure to observe this caution may lead to damage of the boom tip assembly.

WOODEN BLOCK

GN20T01209P1

GN20T01209P1

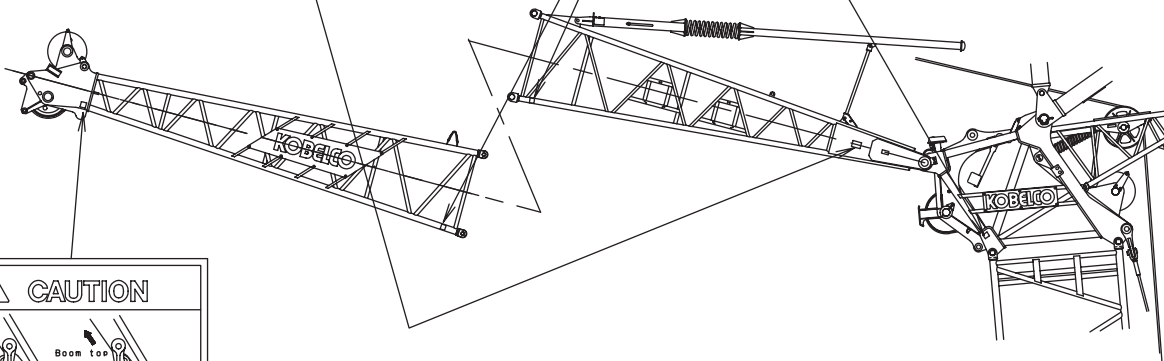

**CAUTION**

CORRECT      WRONG

GG20T01583P1

Install the rope socket in the correct direction. Otherwise, the rope socket or the wire rope may interfere with the boom, causing damage to the boom or cut of the wire rope.

GG20T01583P1

# 1. SAFE OPERATING PRACTICES FOR MOBILE CRANES

### INTRODUCTION

Because cranes have the ability to lift heavy loads to great heights, they also have a potential for accidents if safe operating practices are not followed. This book will help you prevent accidents that could result in injury, death, or property damage.

General safe practices for working on machinery must be followed as well as the safe operating practices recommended here.

### OPERATOR'S RESPONSIBILITY

The operator is the best safety feature in any crane. Safety must always be the operator's most important concern. He must refuse to operate when he knows it is unsafe and consult his supervisor when safety is in doubt.

He must read and understand the Operator's Manual and see that the machine is in proper order before operating.

He must understand how to read the rating plate and know that his machine can safely lift each load before attempting to lift it.

He must never lift a load without knowing the length of the boom, the weight of the load, and the load radius or boom angle.

Never attempt to operate the crane at conditions exceeding those shown on the rating chart. Such operation can cause tipping or structural failure of the crane that can result in damage, injury, or death.

He must be alert, physically fit, and free from the influences of alcohol, drugs, or medications that might affect his eyesight, hearing, reactions, judgment.

He must see that unnecessary people, equipment, and material are kept out of the work area. The area around the machine should be properly barricaded.

When an operator's vision is restricted or when operating in hazardous places such as near electrical power lines or around people, a signalman must be used. Because the operator is not always in the best position to judge distances and can not see all parts of the jobsite, a signalman may also be necessary at other times. Operators must understand standard crane signals and take signals only from designated signalmen.

## **1. SAFE OPERATING PRACTICES FOR MOBILE CRANES**

---

### **SIGNALMAN'S RESPONSIBILITY**

The primary duty of a signalman is to assist the operator in safe and efficient operation. Operators depend on designated signalmen to assist them in making movements without endangering people or property.

Signalmen must have a clear understanding of the work to be done so that they can safely coordinate each job with operators and other crew members. Signalmen must place themselves where they can be clearly seen and where they can safely observe the entire operation. Standard crane signals must be used unless other methods of signaling, such as two way radios or flags have been agreed upon.

### **CREW MEMBER'S RESPONSIBILITY**

Any unsafe condition or practice must be corrected or reported to the job supervisor.

Everyone who works around the crane, including riggers and oilers, must obey all warning signs and watch out for his own safety and the safety of others. Crew members setting up machines or handling loads are expected to know proper machine erection and rigging procedures.

Watch for hazards during operations and alert the operator and signalmen of dangers such as power lines, the unexpected presence of people, other equipment or unstable ground conditions.

### **MANAGEMENT'S RESPONSIBILITY**

See that operators are trained, competent, physically fit and, if required, licensed. Good vision is required, as are good judgment, coordination and mental ability. Any person who lacks any of these qualities must not be allowed to operate a crane.

Signalmen must have good vision and sound judgment, know standard crane signals and be able to give signals clearly. They must have enough experience to be able to recognize hazards and signal the operator to avoid them.

Riggers must be trained to determine weights and distances and to select proper lifting tackle. Rigging is a complex subject far beyond the scope of this manual. It is management's responsibility to employ qualified riggers.

Crew members must be given specific safety responsibilities and instructed to report any unsafe conditions to their supervisors.