

CRAWLER CRANE

SHOP
MANUAL

model **CK1600**
CKE1350

KOBELCO

BOOK CODE : S5GN00003ZE08

SAFETY

1. SPECIFICATION

1.1	CKE1350 SPECIFICATION.....	1-3
1.1.1	PERFORMANCE.....	1-3
1.1.2	PERFORMANCE OF LUFFING JIB.....	1-3
1.1.3	OUTSIDE DIMENSIONS.....	1-4
1.1.4	DIMENSIONS AND WEIGHT OF EACH PARTS.....	1-9
1.1.4.1	BASE MACHINE.....	1-9
1.1.4.2	COUNTERWEIGHT.....	1-11
1.1.4.3	ATTACHMENT.....	1-12
1.1.4.4	TRAVELING STYLE.....	1-16
1.1.5	CKE1350 STABILITY IN SWINGING AND TRAVELING.....	1-18
1.1.5.1	WITHOUT BOOM BASE.....	1-18
1.1.5.2	WITH BOOM BASE.....	1-20
1.2	CK1600 SPECIFICATION.....	1-21
1.2.1	PERFORMANCE.....	1-21
1.2.2	PERFORMANCE OF LUFFING JIB.....	1-21
1.2.3	OUTSIDE DIMENSIONS.....	1-22
1.3	DIMENSIONS AND WEIGHT OF EACH PARTS.....	1-27
1.3.1	BASE MACHINE.....	1-27
1.3.2	COUNTERWEIGHT.....	1-29
1.3.3	ATTACHMENT.....	1-30
1.3.4	STABILITY IN SWINGING AND TRAVELING.....	1-33
1.3.4.1	WITHOUT BOOM BASE.....	1-33
1.3.4.2	WITH BOOM BASE.....	1-35

2. MAINTENANCE STANDARDS

TEST PROCEDURES

2.1	MAINTENANCE STANDARD.....	2-3
2.1.1	PIN, BUSHING, SPRING, LINING AND SHEAVE.....	2-3
2.1.2	PROPEL DEVICE.....	2-10
2.1.3	PROPEL BRAKE PLATE.....	2-18
2.2	PERFORMANCE STANDARD AND TEST PROCEDURE.....	2-19
2.2.1	OPERATING SPEED.....	2-19
2.2.2	POINT AND METHOD OF MEASURING PRESSURE.....	2-20
2.2.3	SLEWING RING.....	2-25

3. GENERAL WORK STANDARD

3.1	TIGHTENING TORQUE OF CAPSCREWS AND NUTS.....	3-3
3.1.1	METRIC COARSE THREADS.....	3-3

TABLE OF CONTENTS

3.1.2	METRIC FINE THREADS	3-3
3.1.3	COARSE THREDS UNC.....	3-4
3.1.4	FINE THREADS UNF	3-4
3.1.5	TIGHTENING TORQUE OF HYDRAULIC FITTINGS.....	3-5
3.2	STANDARD PARTS.....	3-7
3.2.1	BOLT	3-7
3.2.2	O-RING.....	3-8
3.2.3	BACK-UP RING.....	3-9
3.2.4	BITE FITTING.....	3-10
3.3	CONVERSION TABLE.....	3-12
3.3.1	UNIT CONVERSION	3-12
3.3.2	MILLIMETER : INCH CONVERSION TABLE.....	3-13
3.3.3	METER-FOOT CONVERSION TABLE	3-15
3.3.4	GRADIENT CONVERSION TABLE	3-16
3.4	TABLE OF UNIT WEIGHT	3-17
 4. POWER TRAIN		
4.1	INTRODUCTION.....	4-3
4.2	ENGINE.....	4-5
4.2.1	INTRODUCTION	4-5
4.2.2	REMOVAL	4-5
4.2.3	REPAIR AND MAINTENANCE	4-6
4.2.4	RE-INSTALLATION.....	4-7
4.3	PUMP DRIVE ASSEMBLY.....	4-10
4.3.1	INTRODUCTION	4-10
4.3.2	REMOVAL	4-10
4.3.3	DISASSEMBLING THE POWER DIVIDER.....	4-12
4.3.4	CHECK AND REPAIR OF THE POWER DIVIDER.....	4-13
4.3.5	ASSEMBLING THE POWER DIVIDER.....	4-14
4.3.6	RE-INSTALLATION.....	4-15
 5. HYDRAULIC SYSTEM		
5.1	LOCATION OF MAIN HYDRAULIC COMPONENTS	5-3
5.2	HYDRAULIC CIRCUITS AND COMPONENTS	5-4
5.2.1	HYDRAULIC CIRCUIT	5-4
5.2.2	COMPONENT SPECIFICATIONS	5-8
5.2.3	LOCATION OF HYDRAULIC COMPONENTS.....	5-12
5.3	HYDRAULIC SYSTEM.....	5-23
5.3.1	PREFACE.....	5-23

TABLE OF CONTENTS

5.3.2	OUTLINE	5-23
5.3.3	OIL FLOW FROM No.1 and No. 2 PUMPS	5-24
5.3.4	OIL FLOW FROM No.3 AND No.4 PUMPS	5-26
5.3.5	OIL FLOW FROM No.5 PUMP (CONTROL PUMP).....	5-28
5.3.6	OIL FLOW FROM No.6 PUMP (FOR AUXILIARY ACTUATOR CIRCUIT).....	5-31
5.4	VALVES.....	5-34

6. HOIST SYSTEM

6.1	APPARATUS AND LOCATION OF COMPONENTS	6-3
6.2	CONSTRUCTION AND FUNCTION	6-4
6.2.1	HYDRAULIC SCHEMATIC	6-4
6.2.2	LIFTING A LOAD	6-6
6.2.3	HOLDING A RAISED LOAD	6-8
6.2.4	LOWERING A LOAD (POWERED LOWERING)	6-10
6.2.5	FREE FALL OPERATION	6-12
6.2.6	FREE FALL ACCELERATION.....	6-16
6.3	DRUM LOCK	6-18
6.3.1	ASEMBLY DRAWING	6-18
6.3.2	ADJUSTMENT OF DRUM LOCK	6-19
6.4	WINCH ASSEMBLY	6-20
6.4.1	WINCH INSTAL	6-20
6.4.2	WINCH ASSEMBLY / REDUCTION UNIT WITHOUT FREE FALL (STD.).....	6-21
6.4.3	WINCH ASSEMBLY WITH FREE FALL (OPT.).....	6-23
6.5	BRAKE PEDAL.....	6-24
6.5.1	ASSEMBLY DRAWING	6-24
6.5.2	ADJUSTING THE BRAKE PEDAL	6-26
6.6	BLEEDING AIR FROM BRAKE CIRCUIT	6-27

7. BOOM HOIST SYSTEM

7.1	APPARATUS AND LOCATION OF COMPONENTS	7-3
7.2	CONSTRUCTION AND FUNCTION	7-5
7.2.1	HYDRAULIC SCHEMATIC	7-5
7.2.2	RAISING THE BOOM.....	7-6
7.2.3	NEUTRAL (MAINTAINING THE BOOM POSITION)	7-8
7.2.4	LOWERING THE BOOM	7-10
7.3	BOOM DRUM LOCK.....	7-12
7.3.1	ASSEMBLY DRAWING	7-12
7.3.2	ADJUSTING THE BOOM DRUM LOCK.....	7-13

TABLE OF CONTENTS

7.4	DRUM AND REDUCTION UNIT	7-14
7.4.1	BOOM WINCH ASSEMBLY	7-14
7.4.2	BOOM DRUM AND REDUCTION UNIT ASSEMBLY	7-16
8. SWING SYSTEM		
8.1	APPARATUS AND LOCATION OF COMPONENTS	8-3
8.2	CONSTRUCTION AND FUNCTION	8-4
8.2.1	HYDRAULIC SCHEMATIC.....	8-4
8.2.2	SWING	8-6
8.2.3	STOPPING	8-9
8.3	SWING REDUCTION UNIT	8-12
8.4	SWING BEARING	8-14
8.5	SWING LOCK	8-16
9. PROPEL SYSTEM		
9.1	LOCATION OF THE MAJOR COMPONENTS	9-3
9.2	CONSTRUCTION AND FUNCTION	9-4
9.2.1	HYDRAULIC SCHEMATIC.....	9-4
9.2.2	PROPELLING (RIGHT SIDE FORWARD).....	9-6
9.2.3	STOPPING	9-8
9.3	PROPEL REDUCTION UNIT	9-10
9.3.1	MOTOR AND REDUCTION UNIT	9-12
9.4	ADJUSTMENT	9-14
10. ELECTRIC SYSTEM		
10.1	ELECTRICAL WIRING SCHEMATIC.....	10-3
10.2	CONNECTOR LIST.....	10-14
10.3	ARRANGEMENT OF ELECTRICAL PART	10-66
10.3.1	ELECTRICAL PART OF CAB	10-66
10.3.2	ELECTRICAL PART OF RIGHT DECK.....	10-70
10.3.3	ELECTRICAL PART OF FLOOR PLATE & LEFT SIDE STAND PANEL	10-78
10.3.4	ELECTRICAL PART OF REVOLVING FRAME	10-83
10.3.5	ELECTRICAL PART OF LEFT DECK	10-86
10.3.6	ELECTRICAL PART OF LEFT GUARD	10-93
10.3.7	HARNESS PART NUMBER LIST (ALL MODELS)	10-94
10.4	ELECTRICAL PART.....	10-96
10.4.1	LOCATION AND USE OF FUSE.....	10-96
10.4.2	FUSE BOX (GG73E00004F1).....	10-98
10.4.3	WIPER CONTROL UNIT (2480U306).....	10-100

TABLE OF CONTENTS

10.4.4 SWING FLASHER UNIT (2480U306).....	10-101
10.4.5 PRESSURE SWITCH (CONTROL PRESSURE CUT & FREE FALL) (GG52S00006P1).....	10-102
10.4.6 PRESSURE SENSOR.....	10-103
10.4.7 RELAY BOX (GG24E00024F1).....	10-105
10.4.7.1 ARRANGEMENT OF CONNECTOR.....	10-105
10.4.7.2 RELAY BOX SCHEMATIC	10-107
10.4.8 LEFT SIDE STAND PANEL.....	10-110
10.5 TROUBLESHOOTING OF EXHAUST GAS THIRD REGULATION ENGINE.....	10-114
10.5.1 FAILURE DIAGNOSIS FUNCTION	10-114
10.5.2 HOW TO CHECK THE FAILURE CONTENTS	10-115
10.5.3 CHECKING OF DIAGNOSIS LAMP FUNCTION	10-120
10.5.4 ENGINE ECU	10-121

11. LOAD SAFETY DEVICE

11.1 PART NAMES AND FUNCTIONS.....	11-3
11.1.1 FRONT VIEW	11-3
11.1.2 CONFIGURATION OF SCREENS	11-8
11.1.3 DATA TRANSMISSION BETWEEN CONTROLLER AND CARDS	11-13
11.1.4 DETAILS OF INDICATORS ON MAIN DISPLAY SCREEN	11-15
11.1.5 REAR VIEW.....	11-19
11.1.6 ITEMS REQUIRED TO BE EXECUTED FOR REPLACEMENT OF CONTROLLER OR DATA CARD AND INSTRUCTIONS (IN A SIMILAR MANNER TO UPGRADE OF PROGRAM)	11-24
11.2 PREPARATION FOR USE.....	11-25
11.3 TURN THE POWER ON	11-26
11.4 UPGRADING PROGRAMS.....	11-27
11.4.1 PROCEDURES	11-27
11.4.2 UPGRADING OF INDICATION PROGRAMS	11-29
11.4.3 UPGRADING OF CONTROL PROGRAMS	11-32
11.5 STATUS CHECK.....	11-34
11.5.1 SIGNAL CHECK.....	11-35
11.5.2 OPERATION PROGRESS	11-37
11.5.3 COMMUNICATION DATA.....	11-40
11.5.4 INDICATION OF ADJUSTMENT VALUE	11-41
11.5.4.1 ANGLE SENSOR ADJUSTMENT VALUE.....	11-42
11.5.4.2 LOAD CELL ZERO POINT ADJUSTMENT VALUE	11-43
11.5.4.3 ADJUSTMENT VALUE OF LOAD CELL FOR LINE-PULL	11-44
11.5.4.4 RESULT OF MANUFACTURE ADJUSTMENTS "NO LOAD" AND "SOME LOAD"	11-45
11.5.4.5 RESULT OF LOAD ADJUSTMENTS "NO LOAD" AND "SOME LOAD" ..	11-46
11.5.4.6 ADJUSTMENT VALUE OF WORKING RADIUS.....	11-47

TABLE OF CONTENTS

11.5.4.7 ALTERATION OF ADJUSTED VALUE	11-48
11.5.4.8 DELETION OF ADJUSTED VALUE	11-49
11.5.5 TROUBLE RECORD	11-50
11.5.6 CHOICE OF LANGUAGE (CKE SERIES ONLY).....	11-52
11.5.7 LOAD RECORD (LOAD RECORD IN THE MAIN MENU).....	11-53
11.6 ADJUSTMENTS.....	11-54
11.6.1 REMOVING THE INNER PANEL.....	11-54
11.6.2 ADJUSTMENT	11-55
11.6.2.1 ANGLE SENSOR ADJUSTMENT	11-58
11.6.2.2 LOAD CELL ZERO POINT ADJUSTMENT.....	11-62
11.6.2.3 LOAD-LESS ADJUSTMENT & SOME LOAD ADJUSTMENT	11-64
11.6.2.4 LVL ADJUSTMENT (LVL SETTING).....	11-71
11.6.2.5 RADIUS ADJUSTMENT	11-74
11.6.3 LOAD ADJUSTMENT.....	11-76
11.6.4 ADJUSTMENT DATA COPY (INITIALIZATION).....	11-79
11.6.4.1 READING OF THE ADJUSTMENT DATA	11-81
11.6.4.2 WRITING OF ADJUSTMENT DATA	11-83
11.6.4.3 INITIALIZATION OF ADJUSTMENT DATA.....	11-84
11.6.5 VERSION CHECK.....	11-85
11.7 ERROR CODE (ABNORMALITY DETECTION) AND COUNTERMEASURES ...	11-86
11.8 CONTROL OUTPUT	11-90
11.9 RELEASES	11-102
11.9.1 RELEASE FUNCTION	11-102
11.9.1.1 CRANE RELEASE CHART	11-102
11.9.1.2 ALARM SOUND	11-108
11.9.1.3 EXTERNAL INDICATOR LAMPS IN RELEASE CONDITION	11-109
11.10 MECHANICAL SPECIFICATION.....	11-110
11.10.1 ENVIRONMENTAL PERFORMANCE PARAMETERS.....	11-110
11.10.2 LOAD CELL (CRANE).....	11-111
11.10.3 ANGLE SENSOR	11-112
11.10.4 CONTROLLER.....	11-113
11.10.4.1 MODEL NAME.....	11-113
11.10.4.2 SYSTEM INPUT/OUTPUT	11-113
11.10.4.3 MONITOR DISPLAY.....	11-115
11.10.4.4 OPERATION SWITCH	11-115
11.10.4.5 INTERNAL PROCESSING SYSTEM	11-115
11.10.4.6 MEMORY.....	11-115
11.10.4.7 EXTERNAL STORAGE ELEMENT	11-116
11.10.4.8 OTHERS.....	11-116
11.11 EXTERNAL DIMENSIONS	11-117
11.12 ELECTRIC SCHEMATIC DIAGRAM	11-118
11.12.1 CRANE TYPE.....	11-118
11.12.2 LUFFING TYPE.....	11-119
11.13 CONTROLLER MALFUNCTION EMERGENCY MEASURES.....	11-120

TABLE OF CONTENTS

11.14	LOAD SAFETY DEVICE CHECK PROCEDURES	11-121
12. GAUGE CLUSTER		
12.1	CONFIGURATION OF DISPLAY	12-3
12.2	PRIORITY	12-4
12.3	STATUS DISPLAY	12-6
12.4	FAULT LOG DISPLAY	12-16
13. TOTAL CONTROLLER		
13.1	ARRANGEMENT OF TOTAL CONTROLLER	13-3
13.2	COMPOSITION OF SYSTEM	13-4
13.2.1	OUTPUT RELATION TO CONTROLLER	13-5
13.3	FUNCTION OF TOTAL CONTROLLER	13-6
13.4	TOTAL CONTROLLER (HARDWARE)	13-31
13.4.1	OUTLINE	13-31
13.4.2	SPECIFICATIONS OF TOTAL CONTROLLER OUTPUT	13-32
13.4.3	DETAILS OF TOTAL CONTROLLER CONNECTOR	13-36
13.4.4	ARRANGEMENT OF TOTAL CONTROLLER CONNECTOR PIN	13-37
13.4.5	PROPORTIONAL SOLENOID VALVE MEASURING POSITION (VOLTAGE)	13-44
13.5	ADJUSTMENT OF TOTAL CONTROLLER	13-46
13.5.1	NECESSITY OF ADJUSTMENT	13-46
13.5.2	ADJUSTMENT PROCEDURES OF TOTAL CONTROLLER	13-46
13.5.2.1	OPTION SETTING	13-46
13.5.2.2	ADJUSTMENT OF HAND THROTTLE AND FOOT THROTTLE	13-48
13.5.2.3	ENGINE SPEED ADJUSTMENT	13-49
13.5.2.4	WHEN ADJUSTMENT OF TOTAL CONTROLLER IS IMPOSSIBLE	13-50
13.5.2.5	INITIAL ADJUSTMENT OF LIFTING HEIGHT GAUGE	13-51
13.6	CONTROLLER MALFUNCTION EMERGENCY MEASURES	13-53
14. AIR CONDITIONER		
14.1	OPERATION ITEMS	14-3
14.2	SAFETY MONITOR FUNCTIONS	14-4
14.3	DISASSEMBLY AND ASSEMBLY PROCEDURE	14-7
14.3.1	SPECIAL CONSIDERATIONS DURING REPLACEMENT	14-7
14.3.2	INTERIOR UNIT	14-9
14.3.2.1	CASE DISASSEMBLY	14-9
14.3.2.2	THERMOSTAT REPLACEMENT	14-12
14.3.2.3	EVAPORATOR OR EXPANSION VALVE REPLACEMENT	14-13
14.3.2.4	HEATER CORE REPLACEMENT	14-14
14.3.2.5	INTAKE DUMPER ACTUATOR REPLACEMENT	14-15
14.3.2.6	WATER VALVE ACTUATOR OR WATER VALVE REPLACEMENT	14-16
14.3.2.7	MODE ACTUATOR REPLACEMENT	14-17

TABLE OF CONTENTS

14.3.2.8 BLOWER MOTOR ASSEMBLY REPLACEMENT	14-17
14.4 OPERATIONAL PRECAUTIONS.....	14-18
14.5 INSPECTION AND MAINTENANCE.....	14-19
14.5.1 INSPECTION/MAINTENANCE LIST.....	14-19
14.5.2 INSPECTION/MAINTENANCE PROCEDURES	14-19
14.6 ELECTRIC SYSTEM SCHEMATIC.....	14-23

SAFETY

SAFETY

This section explains "Explanation of Warning Description", "Warning Labels" and "General safety"

EXPLANATION OF WARNING DESCRIPTION

This manual indicates the contents of warnings concerned in safety with the following three stages according to the degree of personal harm and material damage.

Since the very important matters for safety are described, understand the contents sufficiently and observe them without fail.



Warning to avoid dangerous condition resulting in instantaneous death or serious personal injury.



Warning to avoid dangerous condition which has possibility of death or serious personal injury.



Warning to avoid dangerous condition which has possibility to cause slight or medium injury or damage of the machine and equipments.

This manual describes safety warnings sufficiently, but dangerous conditions which are impossible to be anticipated are considered.

Therefore, take measures for safety not only regarding the machine, but also including the working environment.

EXPLANATION OF WARNING LABELS

Since the warning labels are installed in the machine and indicated with the three stages in the same way as the warning description, confirm the positions and contents all warning labels first.

Put them to the practical use to secure safety when operating, checking and performing maintenance.

- HANDLING OF WARNING LABELS

1. When the warning label is damaged or stained, order it to the designated service shop.
2. Do not remove the warning labels.
3. When the surface of the warning label is soiled and difficult to be seen, wipe it cleanly.

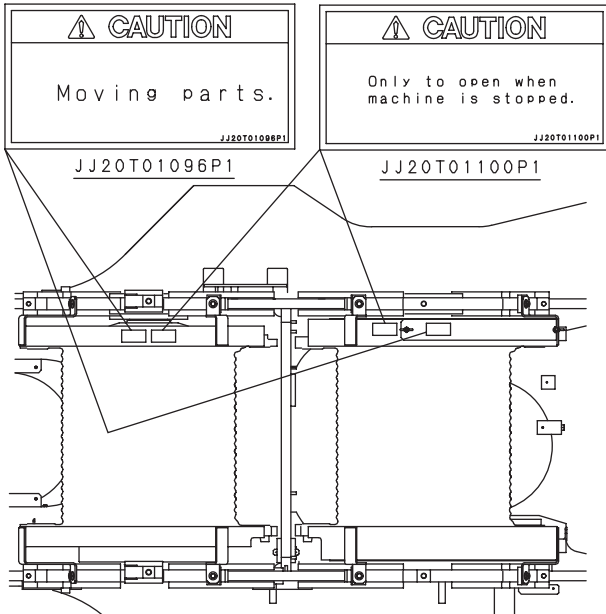

⚠ DANGER

DEATH OR INJURY MAY RESULT IF MACHINE, LOAD, OR LOAD LINE TOUCHES OR COMES CLOSE TO ELECTRICAL LINES. ALWAYS MAINTAIN A CLEARANCE OF AT LEAST 10 FEET (3 METERS) BETWEEN THE CRANE OR THE LOAD BEING HANDLED AND POWERLINES.

UNLAWFUL TO PLACE ANY PART OF THIS MACHINE OR LOAD WITHIN 10 FEET (3 METERS) OF HIGH VOLTAGE LINES OF 50,000 VOLTS OR LESS. GREATER CLEARANCES ARE REQUIRED FOR HIGHER VOLTAGES. SEE YOUR LOCAL, STATE, AND FEDERAL REGULATIONS.

ALWAYS NOTIFY ELECTRIC COMPANY IF THERE ARE ELECTRIC LINES IN THE AREA WHERE MACHINE WILL BE WORKING.

GG20T01127P1

VIEW B

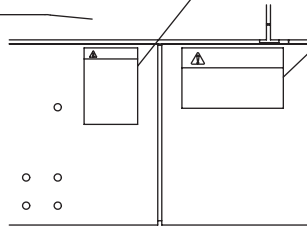

⚠ DANGER

STAY AWAY FROM MACHINE IF CLOSE TO POWER LINES. MACHINE, LOAD AND GROUND MAY BECOME ELECTRIFIED AND DEADLY.

GG20T01128P1

⚠ DANGER

When lock pin is not installed, do not stand under gantry.

JJ20T01097P1

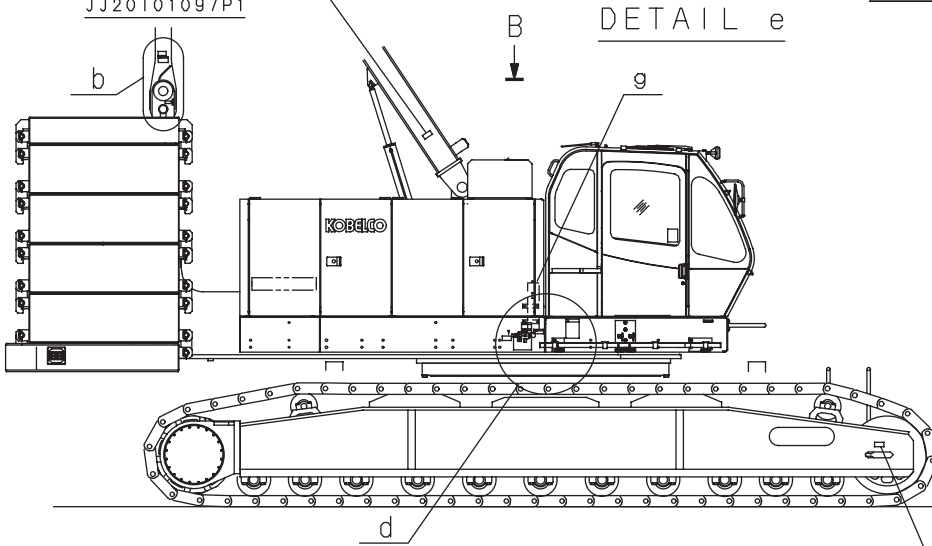

⚠ DANGER

NEVER FORGET TO ENGAGE GANTRY CONNECTION PINS TO AVOID FALLING OF BOOMS. GANTRY CONNECTION PINS MUST BE ENGAGED WHEN GANTRY IS AT HIGH POSITION. ALSO, LOWER PARTS OF TENSION BARS MUST BE CONNECTED TO REVOLVING FRAME OR COUNTERWEIGHT WHEN GANTRY IS AT LOW POSITION.

FP20T01046P1

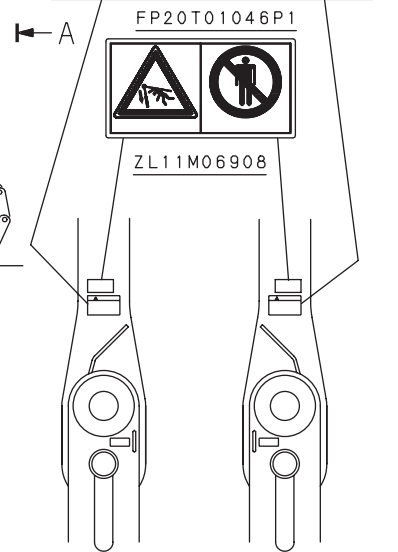

DETAIL b (R/H) DETAIL c (L/H)

⚠ WARNING

AVOID EXPLOSION WHEN HANDLING ACCUMULATOR

THIS CASE IS CHARGED WITH HIGH PRESSURE NITROGEN GAS. NEVER ATTEMPT TO WELD, GAS-CUT, PUT ON FIRE, NOR DISASSEMBLE THE CASE TO AVOID EXPLOSION.

FP20T01042P1

⚠ CAUTION

Moving parts.

JJ20T01096P1

CAUTION
 Not allowed to use main and aux. drums at the same time.
 JJ20T01099P1

CAUTION
 Be careful to keep away from the spaces between the machine and the boom base, when installing the boom base.
 JJ20T01353P1

CAUTION
 Do not crush. Important part inside.
 FP20T01064P1

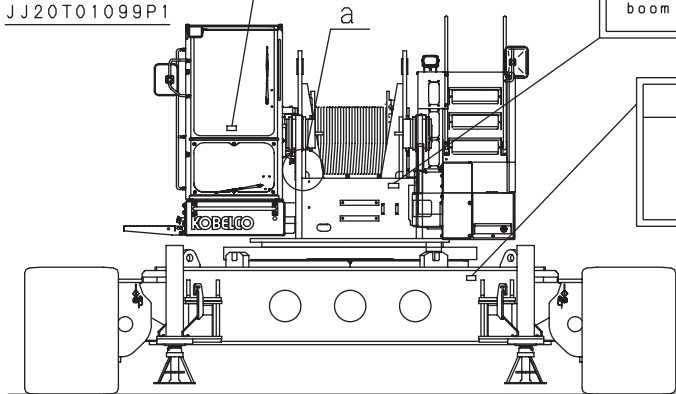

CAUTION
 Moving parts.
 JJ20T01096P1

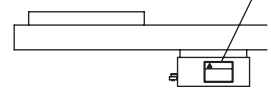

DETAIL A

DANGER
 When lock pin is not installed, do not stand under gantry.
 JJ20T01097P1

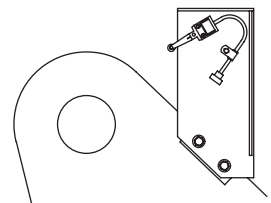

DETAIL a

CAUTION
 Only to open when engine is stopped.
 JJ20T01098P1

CAUTION
 Moving parts.
 JJ20T01096P1

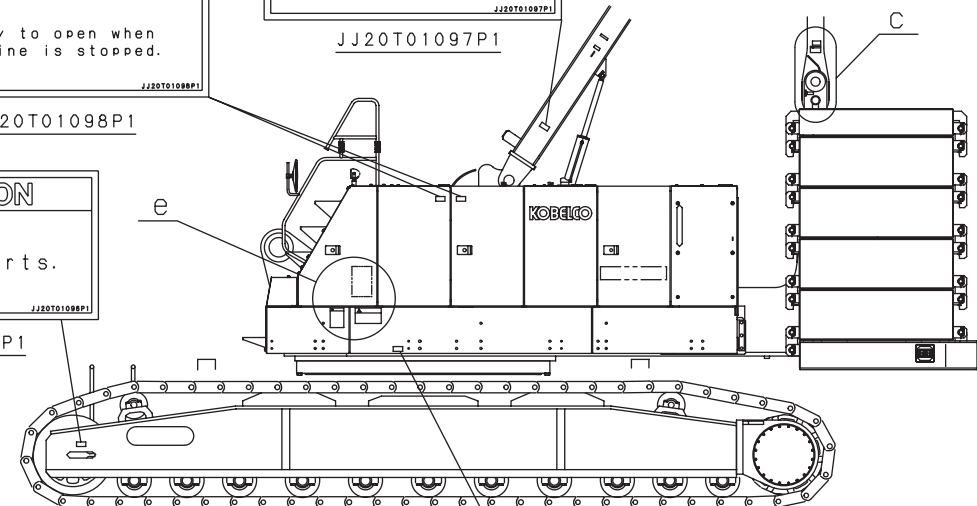

CAUTION
 Stay out from crane swing area.
 JJ20T01095P1

DANGER
WHEN INSTALLATION AND REMOVAL OF THE CRAWLERS (1)
 Do not stand under or near the crawlers being lifted. The lifter should be operated on the firm and level ground with the machine maintained horizontally. Steel plates may be needed under the floats unless the ground is concreted.

WARNING
WHEN INSTALLATION AND REMOVAL OF THE CRAWLERS (2)
 Do not insert finners into pin holes for alignment. The quick couplers must be connected completely.
 JJ20T01102P1

DANGER
 ALL COUNTERWEIGHTS MUST BE REMOVED BEFORE OPERATING THE LIFTER.
 GN20T01041P1

DANGER
 DEATH OR INJURY MAY RESULT IF MACHINE, LOAD, OR LOAD LINE TOUCHES OR COMES CLOSE TO ELECTRICAL LINES. ALWAYS MAINTAIN A CLEARANCE OF AT LEAST 10 FEET (3 METERS) BETWEEN THE CRANE OR THE LOAD BEING HANDLED AND POWERLINES.
 UNLAWFUL TO PLACE ANY PART OF THIS MACHINE OR LOAD WITHIN 10 FEET (3 METERS) OF HIGH VOLTAGE LINES OF 50,000 VOLTS OR LESS. GREATER CLEARANCES ARE REQUIRED FOR HIGHER VOLTAGES. SEE YOUR LOCAL, STATE, AND FEDERAL REGULATIONS.
 ALWAYS NOTIFY ELECTRIC COMPANY IF THERE ARE ELECTRIC LINES IN THE AREA WHERE MACHINE WILL BE WORKING.
 GG20T01127P1

CAUTION
 Stay out from crane swing area.
 JJ20T01095P1

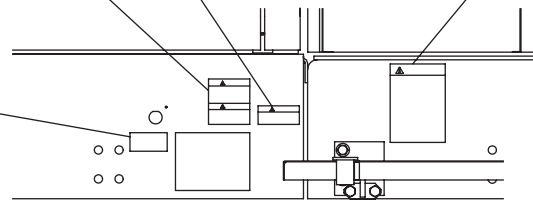

DETAIL d

GG20T01127P1

WARNING



WALKING ON GUARDS MAY CAUSE STUMBLING AT PROJECTED ITEMS AND SLIPPING BY OIL, WATER, OR GREASE.
 PROTECTOR SHOULD BE EMPLOYED WHEN WALKING FOR MAINTENANCE JOB, TO AVOID TIPPING OVER AND FALLING DOWN FROM THE MACHINE.

FP20T01051P1

WARNING

Steam of hot coolant can cause injury or blindness.
 Never loosen or open radiator cap when coolant is hot and under pressure.
 Before opening radiator cap:
 -Cool down engine completely.
 -Cover radiator with cloth rag.
 -Loosen cap slowly to relieve pressure.

YN20T01010P1

FP20T01051P1

YN20T01010P1

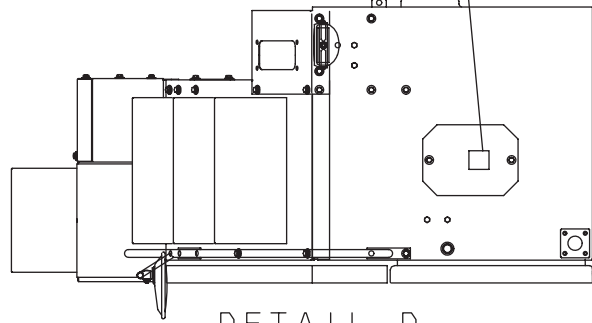
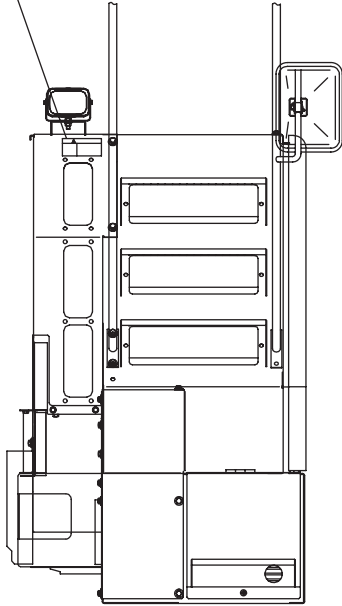

DETAIL D

VIEW C

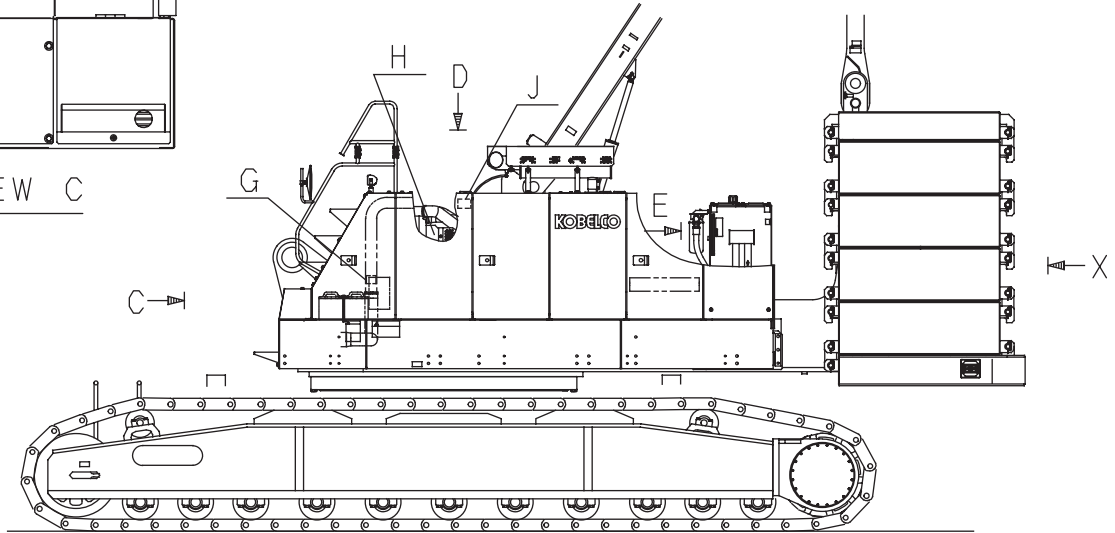

WARNING

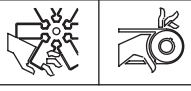

Rotating parts can cause personal injury.
 Keep away from fan and belt when engine is running.
 Stop engine before servicing.

YN20T01009P1

YN20T01009P1

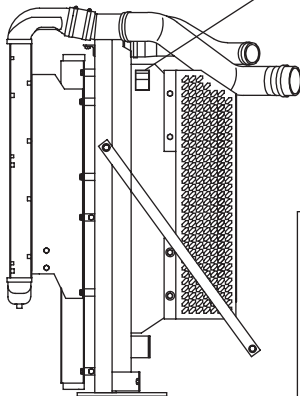

DETAIL H

CAUTION

CAUTION FOR HIGH TEMPERATURE

AS ENGINES AND MUFFLERS MAY BE HEATED TO HIGH TEMPERATURES, DO NOT DIRECTLY TOUCH THEM BY HAND.

FP20T01043P1

FP20T01043P1

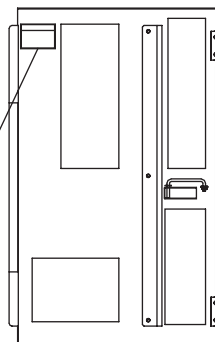

DETAIL J

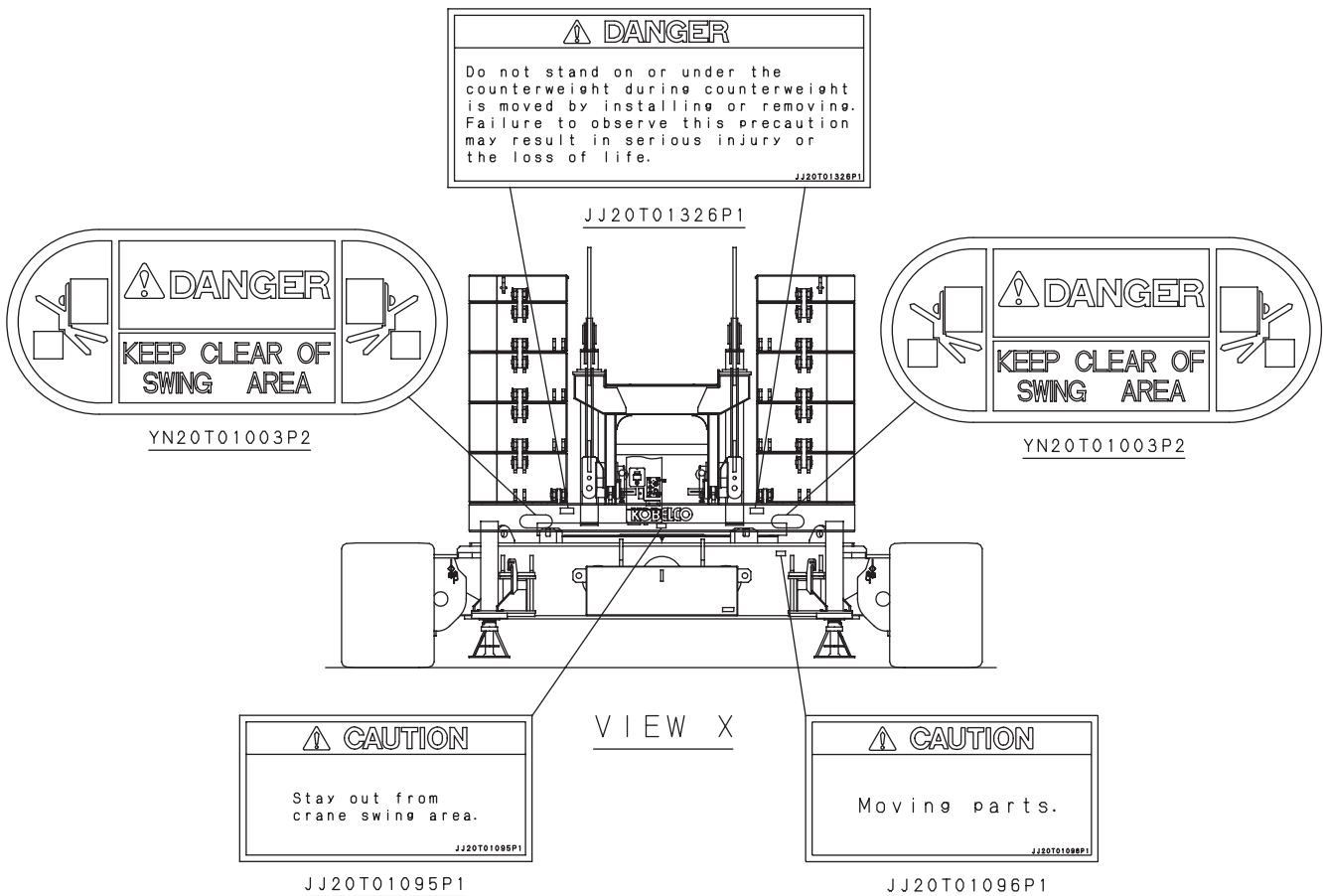
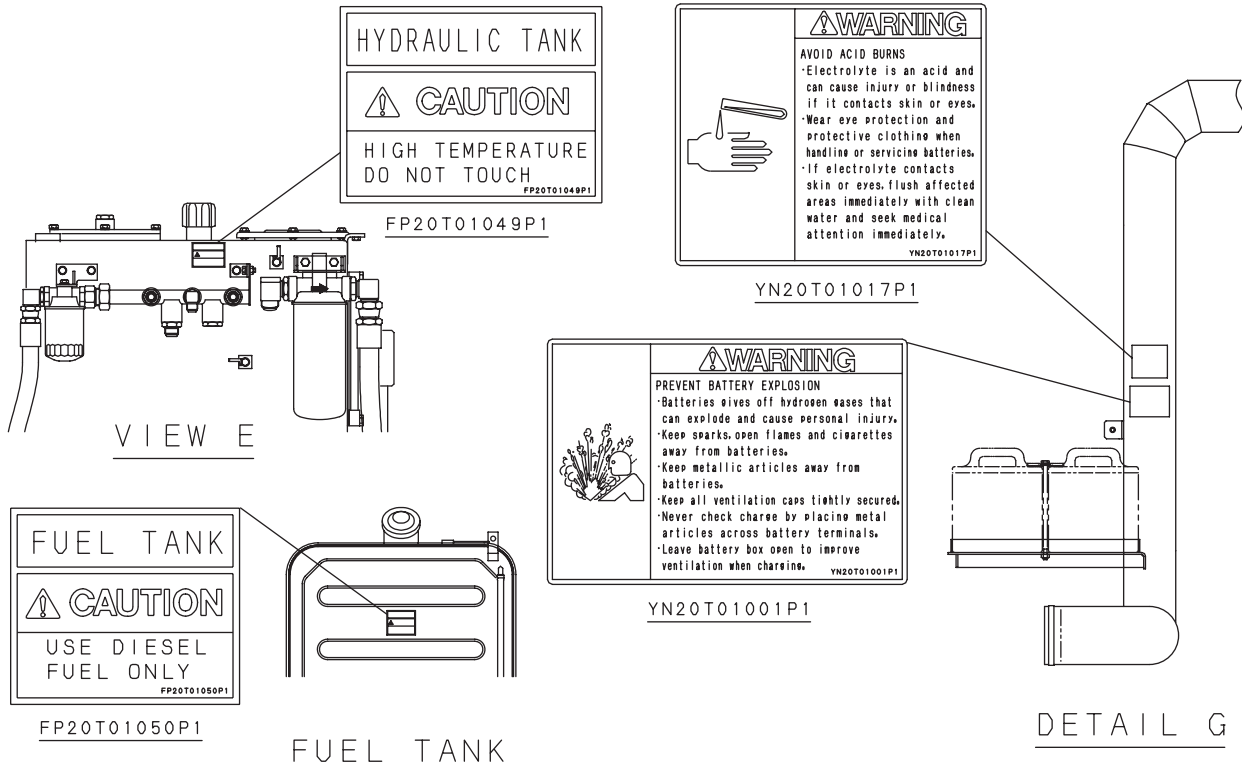

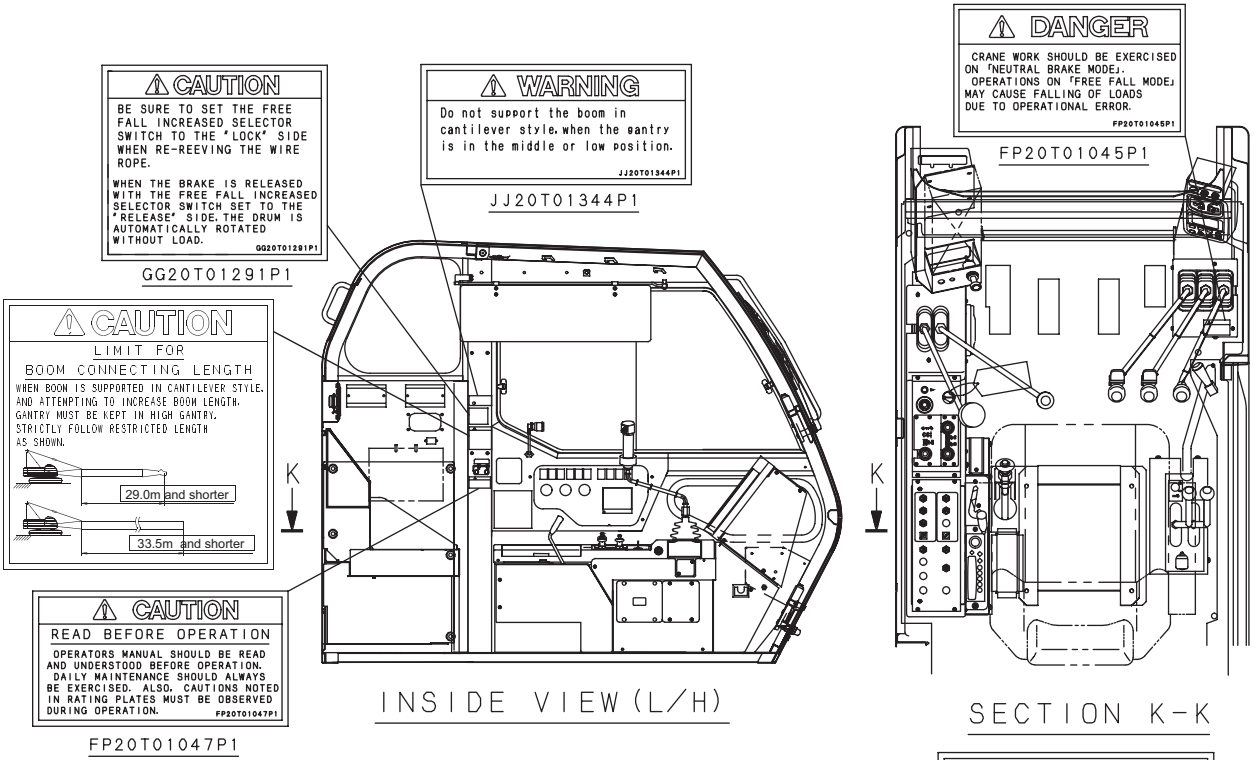

DANGER

DEATH OR INJURY MAY RESULT IF MACHINE, LOAD, OR LOAD LINE TOUCHES OR COMES CLOSE TO ELECTRICAL LINES. ALWAYS MAINTAIN A CLEARANCE OF AT LEAST 10 FEET (3 METERS) BETWEEN THE CRANE OR THE LOAD BEING HANDLED AND POWERLINES.

UNLAWFUL TO PLACE ANY PART OF THIS MACHINE OR LOAD WITHIN 10 FEET (3 METERS) OF HIGH VOLTAGE LINES OF 50,000 VOLTS OR LESS. GREATER CLEARANCES ARE REQUIRED FOR HIGHER VOLTAGES. SEE YOUR LOCAL STATE AND FEDERAL REGULATIONS.

ALWAYS NOTIFY ELECTRIC COMPANY IF THERE ARE ELECTRIC LINES IN THE AREA WHERE MACHINE WILL BE WORKING.

GG20T01127P1

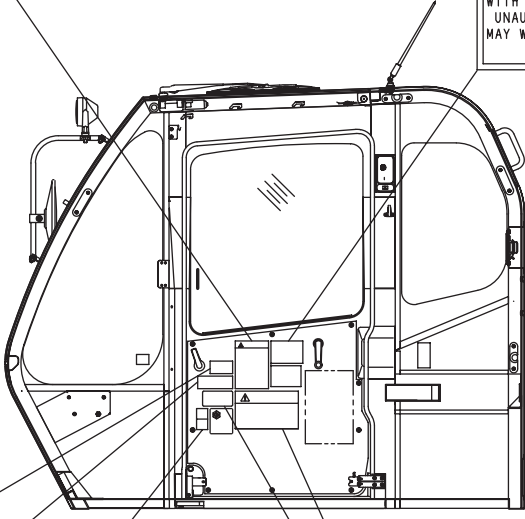

DANGER
Do not swing with the vertical cylinders retracted to avoid turn-over of the trailer. Failure to observe this precaution may result in a serious accident.
JJ20T01347P1

CAUTION
DO NOT LIFT PEOPLE WITH THIS CRANE. FAILURE TO DO SO MAY CAUSE SERIOUS INJURY.
2432T4668



CAUTION
WHEN LOCKING THE BRAKE PEDAL, STEP ON THE PEDAL FULLY TO LOCK THE PAWL AT THE BOTTOM NOTCH.
2432T5113

DANGER

STAY AWAY FROM MACHINE IF CLOSE TO POWER LINES. MACHINE, LOAD AND GROUND MAY BECOME ELECTRIFIED AND DEADLY.

GG20T01128P1

CAUTION

CAUTION FOR USING SPREADER GUIDES

TO AVOID DAMAGE TO SPREADER GUIDES, PLACE THE GUIDES TO STORING POSITION, AFTER SPREADER IS CONNECTED TO LOWER BOOM.

TO AVOID NIPPING OF HANDS OR FINGERS, AT FIRST THE GUIDES SHOULD BE HELD BY HANDS AND PINS DISENGAGED, AND THEN SHOULD BE PLACED IN STORING POSITION.

STORING POSITION WORKING POSITION (BOOM DISASSEMBLING / ASSEMBLING) DISASSEMBLING OF PIN "A"

FP20T01012P1

FP20T01012P1



FOR LOW BOOM

DANGER

DO NOT ENTER UNDER BOOM

TO AVOID SERIOUS INJURY CAUSED BY FALLING OF BOOM, DO NOT ENTER UNDER BOOM WHILE DISASSEMBLING/ASSEMBLING OF BOOM.

FP20T01013P1

FP20T01013P1

CAUTION

CORRECT WRONG

GG20T01561P1

Install the rope socket in the correct direction. Otherwise, the rope socket or the wire rope may interfere with the boom, causing damage to the boom or cut of the wire rope.

GG20T01561P1

DANGER

DO NOT ENTER UNDER BOOM

TO AVOID SERIOUS INJURY CAUSED BY FALLING OF BOOM, DO NOT ENTER UNDER BOOM WHILE DISASSEMBLING/ASSEMBLING OF BOOM.

FP20T01013P1

FP20T01013P1

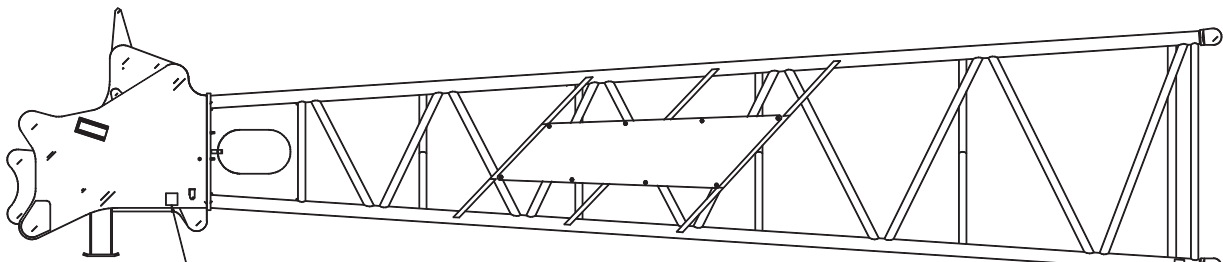
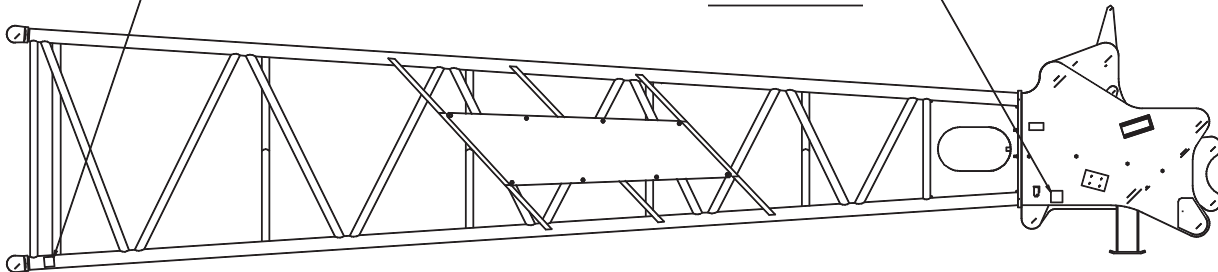

LEFT SIDE VIEW

FOR CR UPP BOOM

CAUTION

CORRECT WRONG

GG20T01583P1

Install the rope socket in the correct direction. Otherwise, the rope socket or the wire rope may interfere with the boom, causing damage to the boom or cut of the wire rope.

GG20T01583P1

DANGER

DO NOT ENTER UNDER BOOM

TO AVOID SERIOUS INJURY CAUSED BY FALLING OF BOOM, DO NOT ENTER UNDER BOOM WHILE DISASSEMBLING/ASSEMBLING OF BOOM.

FP20T01013P1

FP20T01013P1

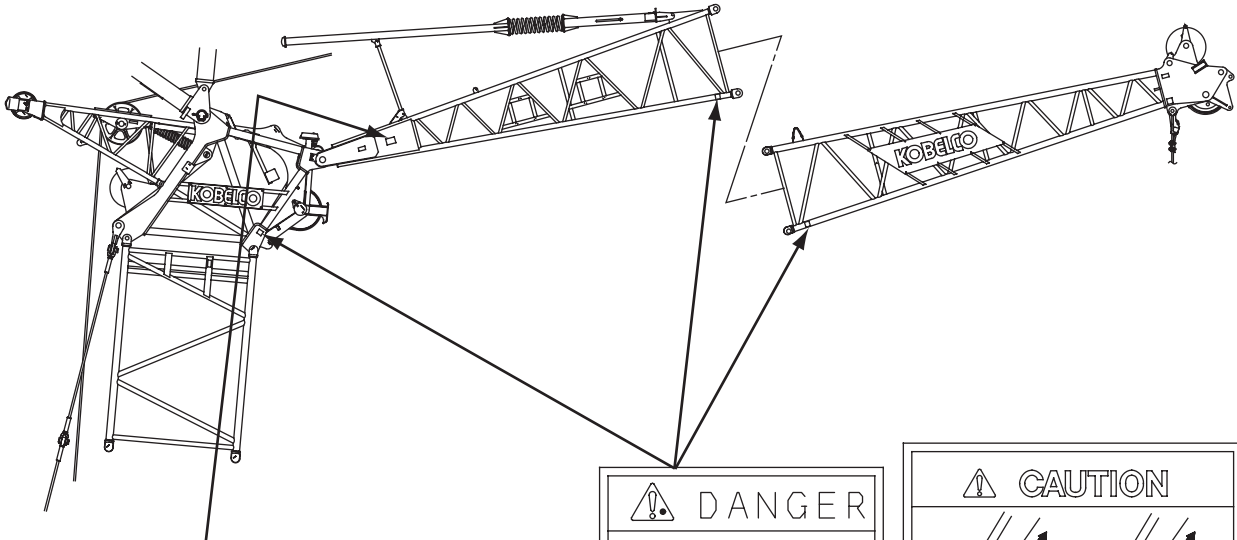

⚠ CAUTION

Be sure to place three (3) same height wooden blocks under the assembly, when transporting or laying on the ground. Failure to observe this caution may lead to damage of the boom tip assembly.

WOODEN BLOCK

GN20T01209P1

⚠ DANGER

DO NOT ENTER UNDER BOOM

TO AVOID SERIOUS INJURY CAUSED BY FALLING OF BOOM, DO NOT ENTER UNDER BOOM WHILE DISASSEMBLING/ASSEMBLING OF BOOM.

FP20T01013P1

⚠ CAUTION

Boom top
Boom foot

CORRECT WRONG

GG20T01562P1

Install the rope socket in the correct direction. Otherwise, the rope socket or the wire rope may interfere with the boom, causing damage to the boom or cut of the wire rope.

FP20T01013P1

GG20T01562P1

GN20T01209P1

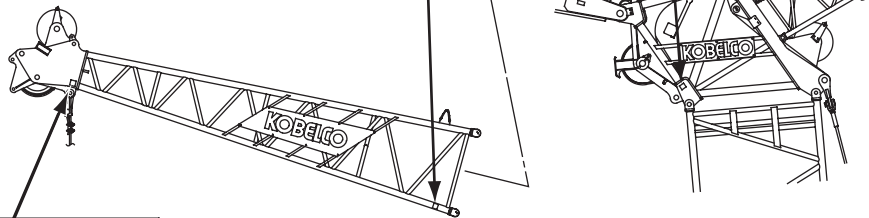

⚠ CAUTION

Boom top
Boom foot

CORRECT WRONG

GG20T01584P1

Install the rope socket in the correct direction. Otherwise, the rope socket or the wire rope may interfere with the boom, causing damage to the boom or cut of the wire rope.

GG20T01583P1

SAFETY**PRECAUTIONS FOR INSPECTION AND MAINTENANCE**

1. Service and maintenance must be performed only by authorized personnel who are qualified in compliance with a relevant law or regulation.
2. Regular maintenance or inspection should be quickly performed after shutting down the machine and ensuring safety to personnel and equipment.
Post an "INSPECTION IN PROGRESS. DO NOT START." warning sign on a readily visible location.

GENERAL SAFETY PRECAUTIONS

1. Wear safety shoes, helmets and clothing suitable for the job. Also use protective goggles, mask, gloves, etc., as required.
2. To ensure safe and correct maintenance, carefully study this SHOP MANUAL and get fully familiar with the instructions in it.
3. Place the machine in a safe place. Always maintain safe clearance around the machine.
4. Before starting crane operation, hold a safety meeting. Also, make agreement on standardized hand signals.
5. When inspecting or handling the battery or oil, do not use exposed flame nearby.
To avoid fire accident, only use explosion-proof lighting equipment.
6. Start an inspection or maintenance work only after shutting down the engine.
7. Certain machine components remain hot immediately after the engine is shut down. Do not touch them.
8. Before removing the radiator cap, wait until the coolant water gets sufficiently cool. Next, carefully loosen the cap and release radiator pressure, and then remove the cap.
9. Before inspecting or maintaining an electrical system on the machine, power off the machine by, for example, disconnecting the battery cables.
10. When working at a high lift area, always wear a safety belt.
11. When leaving the operator's cab for an inspection or maintenance work, post an "INSPECTION IN PROGRESS. DO NOT START." warning sign on a readily visible location. Also, lock the cab for security.
12. Before starting a cleaning or lubrication work on the machine, always shut down the engine.
13. While adjusting tire pressure, be absolutely careful about rupture of a tire, flying of wheel part.
14. Use genuine KOBELCO replacement parts and oils only.
15. Always keep the oil containers clean. Protect them against ingress of dust or moisture. Also, fill clean, fresh oils only.
16. Once a maintenance work is complete, clean the machine.
Protect grease nipples, breathers, and oil level gages against ingress of dust.
17. Always keep the subjects of regular inspection clean to allow problems such as oil leakage, crack, looseness, etc., to be readily detected.
18. During car washing, do not allow high pressure steam to be directly applied to electrical components and connectors.
19. After removing O-rings, oil seals, gaskets, etc., clean the mounting seats. Then, install fresh O-rings, oil seals, gaskets, etc. Also, remember to thinly apply oil to the seal faces of these parts before installation.
20. Before disconnecting pressurized piping, release the inside pressure.
21. CAUTIONs for repair work with welding: Turn OFF the key switch, disconnect the negative terminal on battery to power off the electrical circuit; provide grounding within 1 meter from a weld area; in advance, remove electronic components (for example, controller) to prevent possible damage.
22. Dispose industrial wastes according to a relevant law or regulation.
23. Extremely careful during an inspection or maintenance work under the carrier. Remember the possibility of being crashed.
When jacking up the machine for an inspection or maintenance work, place blocks below it to prevent accidental falling.
24. Provide positive ventilation when refilling oils or fuel, rinsing parts, or starting the engine.