

Mark 8 Series Excavators



Service Support

KOBELCO

KOBELCO Construction Machinery LLC®

A Brand of CNH

Kobelco Mark 8 02/07 Rev . 02

Page 1-1

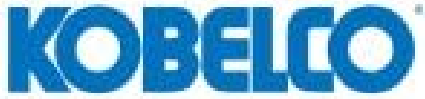

KOBELCO Construction Machinery America LLC

245 E. North Avenue

Carol Stream, IL U.S.A.

Phone: 866-264-6404

Web Page: www.kobelcoamerica.com

Service Support Staff

FIELD SERVICE:

TBA

District Service Manager
NY,RI,CT,MA,ME,NH,VT
PHONE: 630-235-6290

John Adams

District Service Manager
OH,MI
PHONE: 614-864-5863

Scott Emmans

District Service Manager
FL,GA
PHONE: 630-881-8458

David Dunning

District Service Manager
KS,CO,IA,NE
PHONE:630-235-2601

TBA

District Service Manager
KY,TN
PHONE:

Richard Manning

District Service Manager
TX,NM,AZ
PHONE: 936-258-9218

Brian Wise

District Service Manager
WA,OR,ID,MT,WY
PHONE: 630-251-4204

Wes Brubaker

District Service Manager
AL,LA,MS
PHONE: 256-236-6194

Doug Hoernig

District Service Manager
VA,WV,DE,MD
PHONE: 717-227-2179

Rob Hyslop

District Service Manager
ON,PQ,NB,NS,PEI
PHONE: 905-308-5624

Service Support Staff - Cont.

Ken Folden

District Service Manager
BC, Alberta, Sask., Manitoba
PHONE: 403-519-8820

John Rutt

District Service Manager
PA, NJ
PHONE: 717-336-4087

Jeff Schoch

District Service Manager
NC, SC
PHONE: 864-294-9613
FAX:

Bruce Romer

District Service Manager
IL, IN
PHONE: 419-380-9236
FAX: 419-380-9237

Juergen Rymer

District Service Manager
CA, UT, NV, HI
PHONE: 702- 642-0010
FAX: 702-642-5326

Dennis Wojcik

District Service Manager
MN, ND, SD, WI
PHONE: 715-447-8357

Howard Schilling

District Service Manager
OK, AR, MO
PHONE: 630-699-7706
FAX:



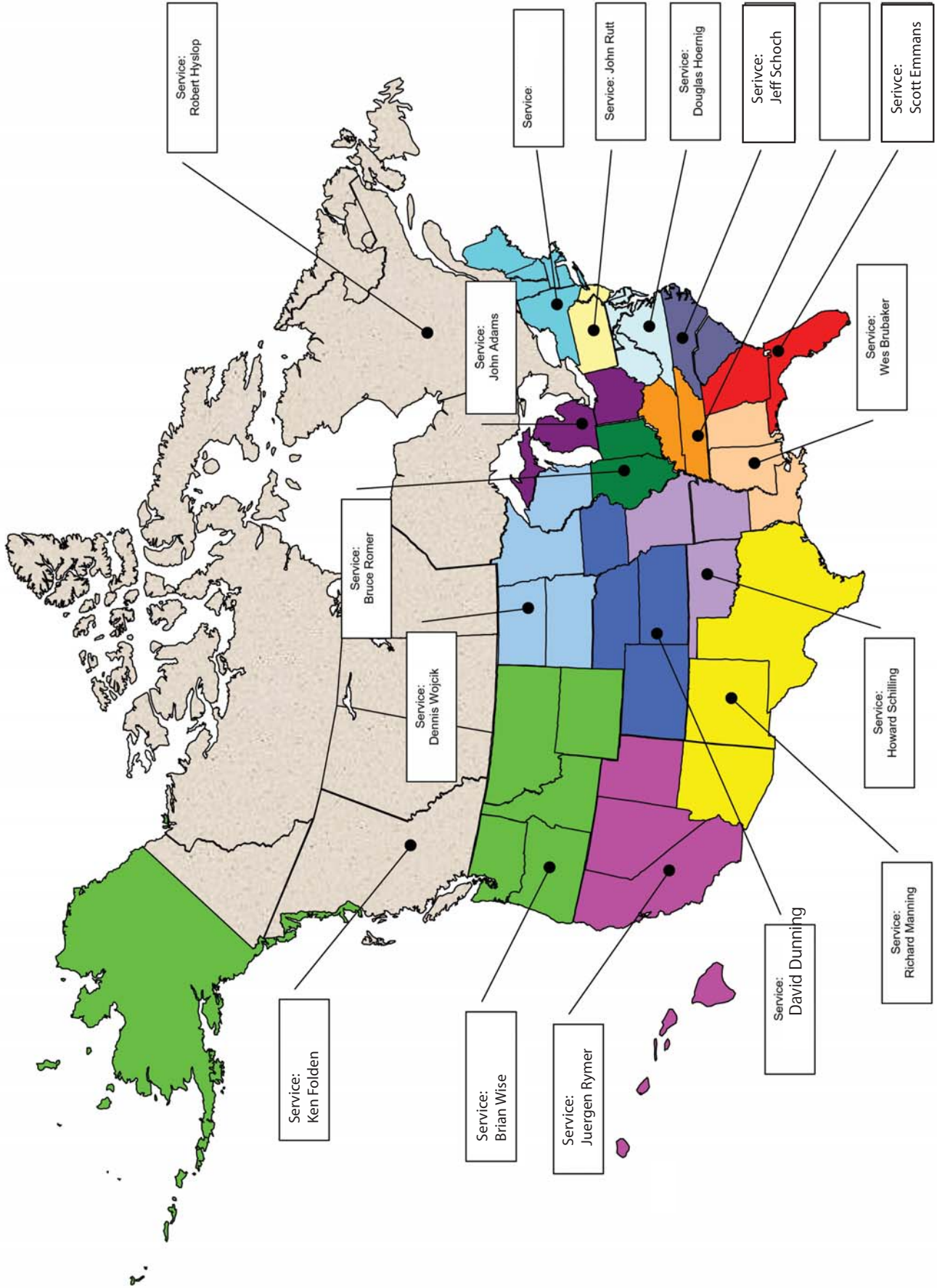

Kobelco

Mark 8

Series



Kobelco Construction Machinery America LLC



Safety

KOBELCO

Kobelco Construction
Machinery America LLC

SAFETY PRECAUTIONS

1.1 GENERAL SAFETY INFORMATION

 WARNING 
<p>Do Not operate or perform any maintenance on this machine until all instructions found in this manual have been thoroughly read and understood. Improper operation or maintenance of this machine may cause accidents and could result in serious injury or death.</p> <p>Always keep this manual in the operators seat pocket.</p> <p>If it is missing or damaged, place an order with an authorized KOBELCO distributor for a replacement. If you have any questions, please consult an authorized KOBELCO distributor.</p>

1. Most accidents, which occur during operation, are due to neglect of precautionary measures and safety rules. Sufficient care should be taken to avoid these accidents. Erroneous operation, lubrication or maintenance services are very dangerous and may cause injury or death of personnel. Therefore all precautionary measures, NOTES, DANGERS, WARNINGS and CAUTIONS contained in this manual and on the machine should be read and understood by all personnel before starting any work with or on the machine.
2. Operation, inspection, and maintenance should be carefully carried out, and safety must be given the first priority. Messages of safety are indicated with marks. The safety information contained in this manual is intended only to supplement safety codes, insurance requirements, local laws, rules and regulations.
3. Messages of safety appear in this manual and on the machine. All messages of safety are identified by the words "DANGER", "WARNING" and "CAUTION".
 - a. **DANGER** – Indicates an imminently hazardous situation which, if not avoided, will result in death or serious injury and is represented as follows:

 DANGER 

- b. **WARNING** – Indicates a potentially hazardous situation which, if not avoided, could result in death or serious injury and is represented as follows:



 WARNING 
--

- c. **CAUTION** – Indicates a potentially hazardous situation which, if not avoided, may result in minor or moderate injury. It may also be used to alert against possible damage to the machine and its components and is represented as follows:

 CAUTION 
--

4. It is very difficult to forecast every danger that may occur during operation. However, safety can be ensured by fully understanding proper operating procedures for this machine according to methods recommended by KOBELCO.
5. While operating the machine, be sure to perform work with great care, so as not to damage the machine, or allow accidents to occur.
6. Continue studying this manual until all Safety, Operation and Maintenance procedures are completely understood by all persons working with the machine.

1.2 SAFETY PRECAUTIONS

 WARNING 
<p>The proper and safe lubrication and maintenance for this machine, recommended by KOBELCO, is outlined in the OPERATORS MANUAL for this machine.</p> <p>Improper performance of lubrication or maintenance procedures are dangerous and could result in injury or death. Read and understand the OPERATORS MANUAL before performing any lubrication or maintenance.</p>

The serviceman or mechanic may be unfamiliar with many of the systems on this machine. This makes it important to use caution when performing service work. A knowledge of the system and or components is important before the removal or disassembly of any component.

Because of the size of some of the machine components, the serviceman or mechanic should check the weights noted in this manual. Use proper lifting procedures when removing any components. Weight of components table for SK210(LC)-VI is shown in Page 6-5 and for SK250(LC)-VI in page 6-23 of Section VI - SPECIFICATIONS.

SAFETY PRECAUTIONS

The following is a list of basic precautions that must always be observed.

1. Read and understand all Warning plates and decals on the machine before Operating, Maintaining or Repairing this machine.
2. Always wear protective glasses and protective shoes when working around machines. In particular, wear protective glasses when using hammers, punches or drifts on any part of the machine or attachments. Use welders gloves, hood/goggles, apron and the protective clothing appropriate to the welding job being performed. Do not wear loose fitting or torn clothing. Remove all rings from fingers, loose jewelry, confine long hair and loose clothing before working on this machinery.
3. Disconnect the battery and hang a "Do Not Operate" tag in the Operators Compartment. Remove ignition keys.
4. If possible, make all repairs with the machine parked on a level, hard surface. Block the machine so it does not roll while working on or under the machine. Hang a "Do Not Operate" tag in the Operators Compartment.
5. Do not work on any machine that is supported only by lift, jacks or a hoist. Always use blocks or jack stands, capable of supporting the machine, before performing any disassembly.

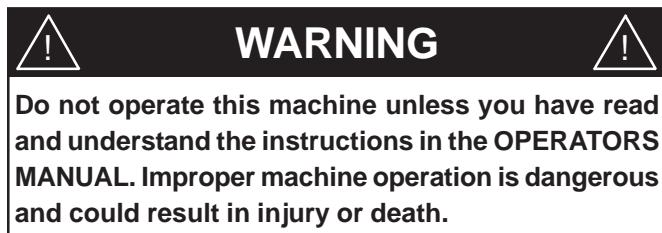

6. Relieve all pressure in air, oil or water systems before any lines, fittings or related items are disconnected or removed. Always make sure all raised components are blocked correctly and be alert for possible pressure when disconnecting any device from a system that utilizes pressure.
7. Lower the bucket, blade, or other attachments to the ground before performing any work on the machine. If this cannot be done, make sure the bucket, blade, ripper or other attachment is blocked correctly to prevent it from dropping unexpectedly.
8. Use steps and grab handles when mounting or dis-

mounting a machine. Clean any mud, grease, oil, or debris from steps, walkways or work platforms before using. Always face the machine when using steps, ladders and walkways. When it is not possible to use the designed access system, provide ladders, scaffolds, or work platforms to perform safe repair operations. Refer to item M on page 1-3.

9. To avoid back injury, use a hoist when lifting components which weigh 23 kg (50 lbs) or more. Make sure all chains, hooks, slings, etc., are in good condition and are the correct capacity. Be sure hooks are positioned correctly. Lifting eyes are not to be side loaded during a lifting operation.
10. To avoid burns, be alert for hot parts on machines which have just been stopped and hot fluids in lines, tubes and compartments.
11. Be careful when removing cover plates. Gradually back off the last two bolts or nuts located at opposite ends of the cover or device and carefully pry cover loose to relieve any spring or other pressure, before removing the last two bolts or nuts completely.
12. Be careful when removing filler caps, breathers and plugs on the machine. Hold a rag over the cap or plug to prevent being sprayed or splashed by liquids under pressure. The danger is even greater if the machine has just been stopped because fluids can be hot.
13. Always use the proper tools that are in good condition and that are suited for the job at hand. Be sure you understand how to use them before performing any service work.
14. Reinstall all fasteners with the same part number. Do not use a lesser quality fastener if replacements are necessary.
15. Repairs which require welding should be performed only with the benefit of the appropriate reference information and by personnel adequately trained and knowledgeable in welding procedures. Determine type of metal being welded and select correct welding procedure and electrodes, rods or wire to provide a weld metal strength equivalent at least to that of the parent metal. Make sure to disconnect battery before any welding procedures are attempted.

SAFETY PRECAUTIONS

16. Do not damage wiring during removal operations. Reinstall the wiring so it is not damaged nor will be damaged in operation of the machine by contacting sharp corners, or by rubbing against some object or hot surface. Do not connect wiring to a line containing fluid.
17. Be sure all protective devices including guards and shields are properly installed and functioning correctly before starting a repair. If a guard or shield must be removed to perform the repair work, use extra caution and replace the guard or shield after repair is complete.
18. The maintenance and repair work while holding the bucket raised is dangerous due to the possibility of a falling attachment. Don't fail to lower the attachment and place the bucket to the ground before starting the work.
19. Loose or damaged fuel, lubricant and hydraulic lines, tubes and hoses can cause fires. Do not bend or strike high pressure lines or install ones which have been bent or damaged. Inspect lines, tubes and hoses carefully. Do not check for leaks with your hands. Very small (pinhole) leaks can result in a high velocity oil stream that will be invisible close to the hose. This oil can penetrate the skin and cause personal injury. Use cardboard or paper to locate pin hole leaks.
20. Tighten connections to the correct torque. Make sure that all heat shields, clamps and guards are installed correctly to avoid excessive heat, vibration or rubbing against other parts during operation. Shields that protect against oil spray onto hot exhaust components in event of a line, tube or seal failure must be installed correctly.
21. Do not operate a machine if any rotating part is damaged or contacts any other part during operation. Any high speed rotating component that has been damaged or altered should be checked for balance before reusing.
22. Be careful when servicing or separating the tracks. Chips can fly when removing or installing a track pin. Wear safety glasses and long sleeve protective clothing. Tracks can unroll very quickly when separated. Keep away from front and rear of machine. The machine can move unexpectedly when both tracks are disengaged from the sprockets. Block the machine to prevent it from moving.
23. Caution should be used to avoid breathing dust that may be generated when handling components containing asbestos fibers. If this dust is inhaled, it can be hazardous to your health. Components in KOBELCO products that may contain asbestos fibers are brake pads, brake band and lining assemblies, clutch plates and some gaskets. The asbestos used in these components is usually bound in a resin or sealed in some way. Normal handling is not hazardous as long as airborne dust which contains asbestos is not generated.

If dust which may contain asbestos is present, there are several common sense guidelines that should be followed.

- a. Never use compressed air for cleaning.
- b. Avoid brushing or grinding of asbestos containing materials.
- c. For clean up, use wet methods or a vacuum equipped with a high efficiency particulate air (HEPA) filter.
- d. Use exhaust ventilation on permanent machining jobs.
- e. Wear an approved respirator if there is no other way to control the dust.
- f. Comply with applicable rules and regulations for the work place.
- g. Follow environmental rules and regulations for disposal of asbestos.
- h. Avoid areas where asbestos particles may be in the air.

SAFETY PRECAUTIONS

1.3 PRE-START SAFETY

Many failures that occur during machine operation or servicing result from neglecting fundamental safety precautions. The following safety precautions are given to prevent such failures, but they are only a part of what you must follow. Read, understand and follow all safety precautions found in this manual and on the machine thoroughly before operating the machine.

A. OBSERVE SAFETY PRECAUTIONS

Follow all safety rules, precautions, and operating procedures. If there are other personnel and flagmen working in the area, have them observe the specified signs.

B. WEAR PROTECTIVE CLOTHING

Wear well fitting safety shoes, hard hat, and working clothes, and put on protective glasses, face shield, ear protection and gloves. When necessary, wear reflective vest.

C. READ and UNDERSTAND THE OPERATORS MANUAL

Before operating the machine, read and understand this operators manual thoroughly in order to use the machine effectively and safely.

D. KEEP OPERATORS MANUAL IN MACHINE CAB

Keep this manual in the specified storage area located behind the operators seat for quick reference. Should the operators manual become lost or damaged, contact an authorized KOBELCO distributor to order the operators Manual.

E. HOW TO HANDLE LIFE HAMMER

A life hammer is provided on the right side of cab. In case of emergency, take the life hammer, break the cab glass, and escape from the cab. In addition, the life hammer is equipped with a cutter on the lever side to cut the seat belt, etc.

F. PREPARE FOR EMERGENCIES

Have a fire extinguisher and first aid kit ready for emergencies. Know how to operate the fire extinguisher and know where the First Aid Kit is located for easy access in case of emergency.

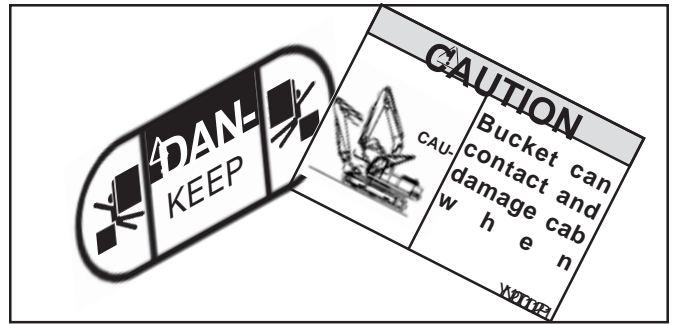

OBSERVE ALL SAFETY PRECAUTIONS

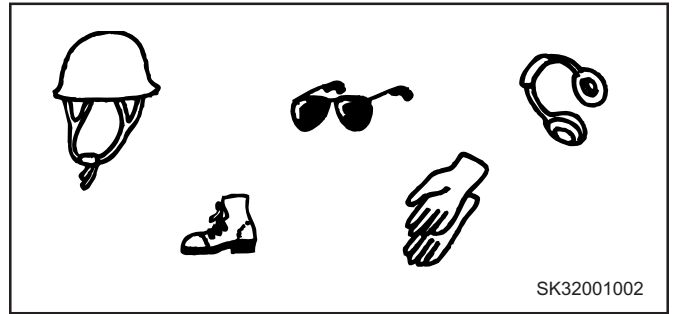

SK32001002

WEAR PROTECTIVE CLOTHING

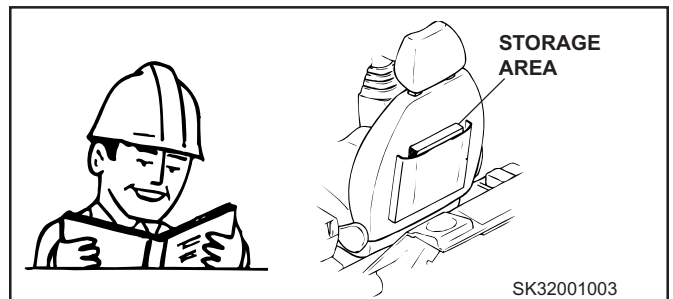

SK32001003

READ MANUAL / KEEP IN MACHINE CAB

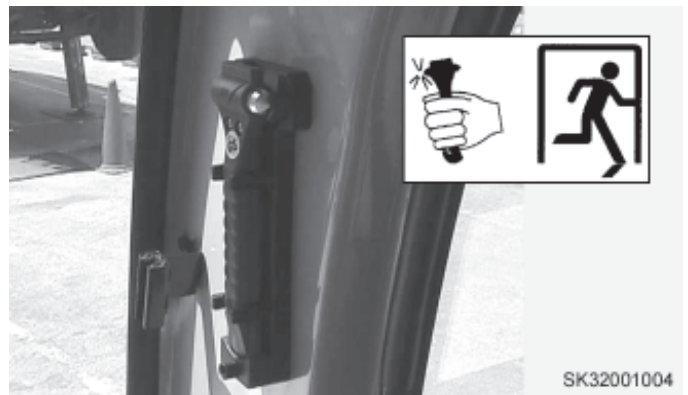

SK32001004

HOW TO HANDLE LIFE HAMMER

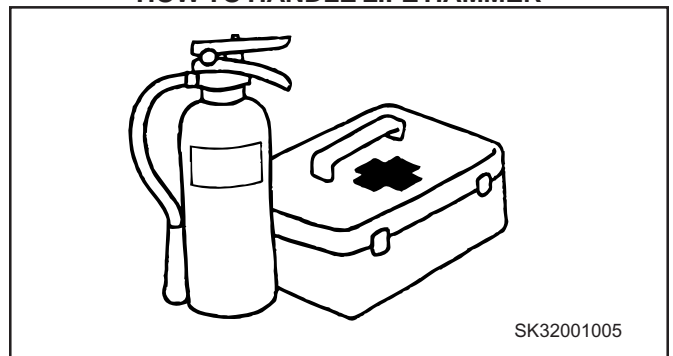

SK32001005

PREPARE FOR EMERGENCIES

SAFETY PRECAUTIONS

G. ENSURE SAFETY AT THE WORK SITE

Know the work area! Before operating the machine, carefully survey and record the land and worksite features to prevent the machine from falling or the soil from caving in.

H. PERFORM PRE-START INSPECTION

Before starting the machine, perform a PRESTART inspection of the machine. If any problems are found, repair or replace defective components immediately.

DO NOT OPERATE THE MACHINE

until all problem areas are properly repaired. Always keep the windshield, working lamps, and mirrors clean for good visibility.

I. ENGAGE SAFETY LOCK LEVER BEFORE LEAVING MACHINE

Before leaving the operator's seat, move the safety lock lever to the "LOCKED" (Up) position. This will not allow operation of any hydraulic controls should they be accidentally moved. If the lever is not set to the "LOCKED" position and hydraulic controls are touched accidentally, the machine may move suddenly resulting in serious injury. Also before leaving the machine, lower the bucket to the ground, place the safety lock lever in the "LOCKED" (Up) position, stop the engine and remove the starter switch key.

J. SIGNS, SIGNALS & FLAGMEN

Install signs on soft shoulders and ground areas, have a flagman direct the operation if necessary. The operator should note marks and follow signals from the flagman. All personnel should know the meaning of the signs, marks, and signals. Only one flagman should give the signs and signals.

K. KEEP FIRE AWAY FROM FUEL AND OIL

Oil, antifreeze, and especially fuel are highly flammable. Never use fire near the machine. Securely tighten all fuel and oil caps. Keep fuel and oil in the designated storage areas. Promptly clean up any all spills and dispose of waste properly.

L. USE CAUTION NEAR NOISE

If noise is high during operation, hearing loss may result. Approved hearing protection should be used if personnel will be exposed to high noise levels for a long period of time.

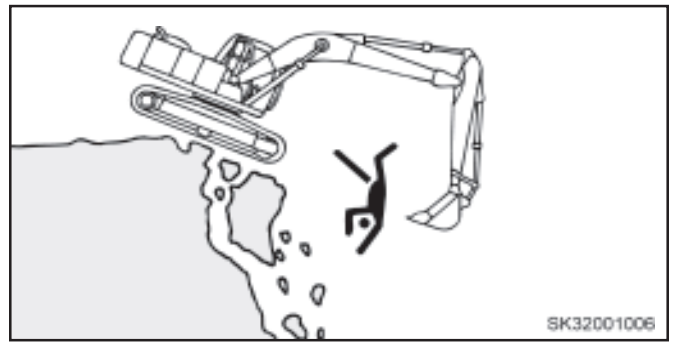

SK32001006

WORKSITE SAFETY- KNOW THE AREA

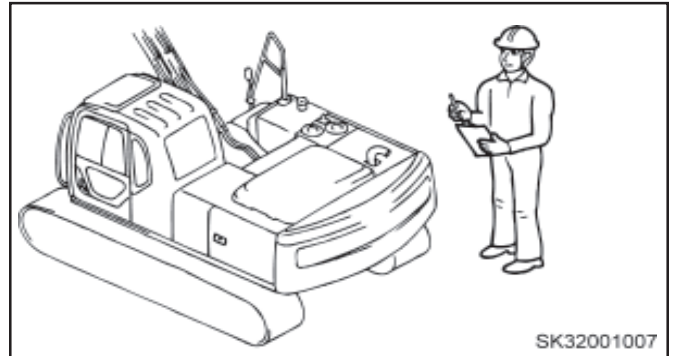

SK32001007

PRE-START INSPECTION OF MACHINE

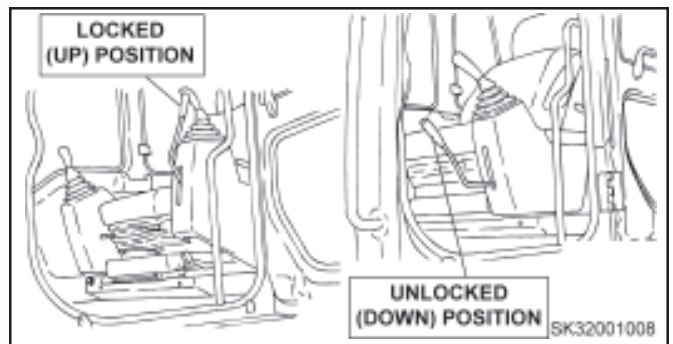

SK32001008

SAFETY LOCK LEVER



SK32001009

KEEP FIRE AWAY FROM FUEL & OIL

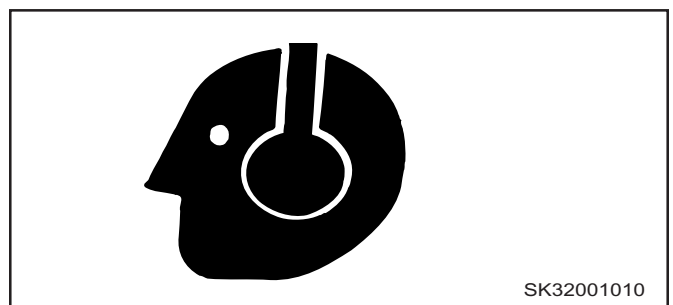

SK32001010

USE CAUTION NEAR NOISE

SAFETY PRECAUTIONS

M. MOUNTING & DISMOUNTING MACHINE

When getting on and off the machine, always maintain three point contact by using the handrails and step. Inspect and clean handrails, step, and mounting parts. Remove slippery materials, such as lubricants, and mud. Always place the cab door entrance parallel to the tracks before stopping the engine for dismounting.

N. AVOID HOT SURFACES & AREAS

Immediately after the machine is operated, the temperature and pressure of the engine coolant, engine oil, and hydraulic oil are very high. Burns may result if caps are removed, or oil, water, or filters are changed under these conditions. Wait until the temperature goes down, before attempting to check fluids or change filters.

O. USE THE PROPER OPTIONAL ATTACHMENT

Use only optional attachments designed for and approved by KOBELCO. Read, understand and follow all instructions in the manual accompanying the optional attachment. Use of any optional attachment not approved by KOBELCO in writing, can cause serious injury to personnel, damage to the machine and its components and shorten the life of the machine. Contact an authorized KOBELCO Dealer for optional attachments available for the machine.

P. PREVENT FIRES

Leaking or spilled fuel, lubricants and hydraulic oil are fire hazards. Clean and properly dispose of spills as they occur. Repair or replace all leaking components to prevent fire. Also, clean the machine regularly removing all debris to help prevent fires, pay particular attention to removal of leaves, sticks, paper etc. Keep fire extinguisher in an accessible area and know how to use the fire extinguisher should a fire occur.

1.4 SAFETY DURING OPERATION

A. STARTING ENGINE

Sit in the operator's seat. Sound the horn before starting the engine to alert people the machine is being started. Make sure no one is near the machine. Do not short circuit the starter circuit or battery to start the engine. This may cause serious injury or cause damage the electrical system.

MOUNTING/DISMOUNTING MACHINE



MOUNTING/DISMOUNTING MACHINE

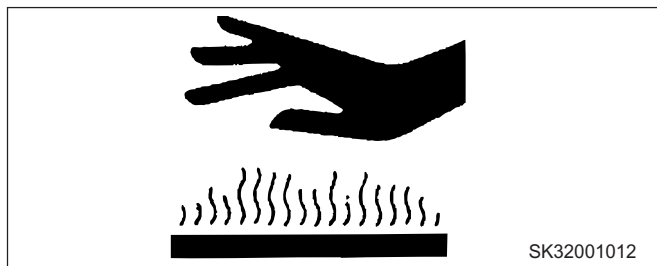

HOT SURFACES

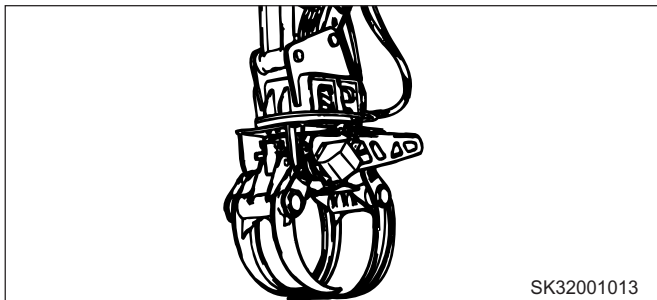

USE PROPER ATTACHMENT



PREVENT FIRES- CLEAN UP SPILLS



SOUND HORN BEFORE STARTING

SAFETY PRECAUTIONS

B. PASSENGERS

This equipment is not intended or designed for the transportation of persons. Never allow persons to ride on the machine. Serious injury or death can result from allowing passengers on or in the machine.

C. TRAVEL

Make certain of the location of the travel motors before operating travel controls. Sound horn before moving the machine to inform persons that the machine is travelling. Position the attachment as shown in illustration before beginning travel. Move the machine at slow speeds. Do not turn suddenly on rough terrain. Avoid travelling over obstacles. Should it become necessary to travel over an obstacle, keep the attachment low to the ground and travel at extremely slow speed.

D. SWING

Make certain the swing area of machine is clear of all persons and obstacles before operating swing controls. Sound horn before swinging machine. If necessary, have a flagman signal operator during operation to help prevent injury to persons or damage to obstacles and equipment.

E. BOOM, ARM & ATTACHMENTS

Give the work you are doing your undivided attention. Make certain the attachment being used is suited for the job at hand. Make certain of obstacles in the work area and operate the machine within those limits. If necessary have a flagman signal the operator to prevent injury to persons or damage to the machine or obstacles in the work area. ALWAYS PLACE ATTACHMENTS ON THE GROUND AND RAISE THE SAFETY LOCK LEVER BEFORE LEAVING THE CAB.

F. OPERATING ON INCLINES OR SLOPES

Operation of this machine on an incline or slope may cause the machine to become unstable or unbalanced. Work up and down inclines or slopes never across. Never Swing or turn machine around on slopes. Build a level area for the machine to operate. Operate controls carefully to prevent sudden movements which may cause the machine to slide or tip over. Use a flagman to direct the operator.

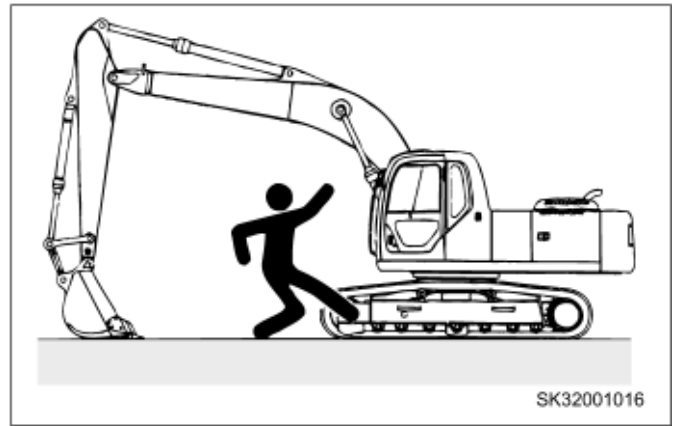

NO PASSENGERS



KNOW TRAVEL MOTOR POSITION



SWING SAFETY / USE SWING FLASHERS

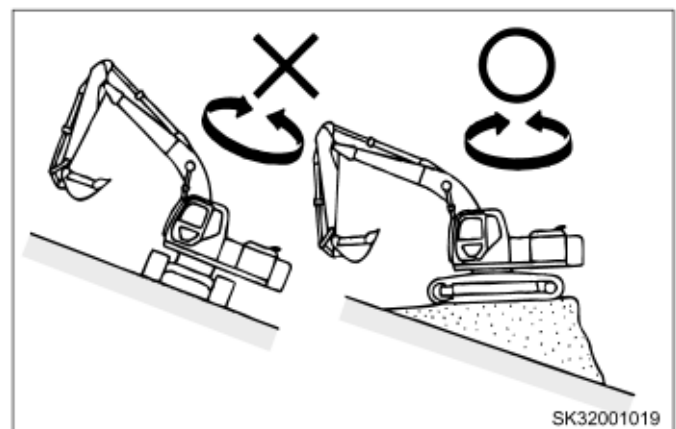

BUILD BANKING FOR SLOPE OPERATION

SAFETY PRECAUTIONS

G. WORKING AROUND UTILITIES

If it is suspected that utility lines such as, gas, water, phone or electrical power are in the work area, contact the local utility authority for line location **BEFORE** beginning work in the area. Use extreme caution around electrical power lines. Keep a sufficient distance away from electrical lines during operation. See chart below for minimum distances.

LINE VOLTAGE	MINIMUM DISTANCE-M (FEET)
0 ~50,000	3.0M (10)OR MORE
50,000 ~200,000	4.5M (15)OR MORE
200,000 ~350,000	6.0M (20)OR MORE
350,000 ~500,000	7.5M (25)OR MORE
500,000 ~750,000	10.5M (35)OR MORE
750,000 ~1,000,000	13.5M (45)OR MORE

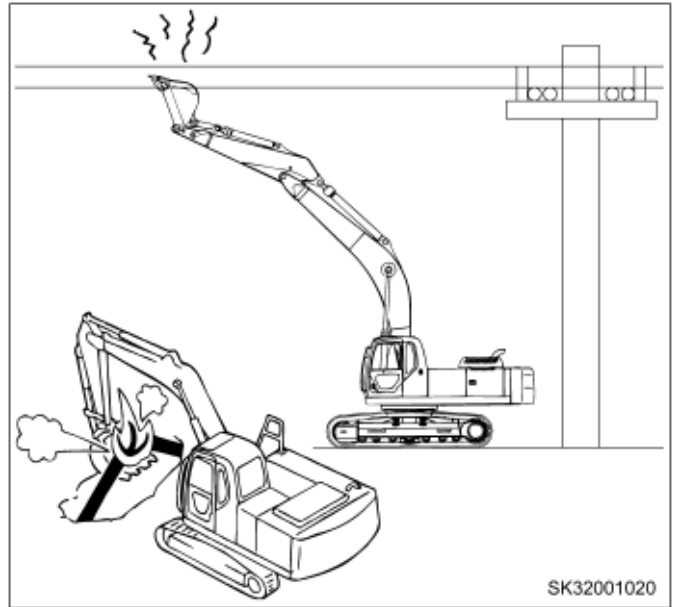

SK32001020

KEEP A SAFE DISTANCE FROM UTILITIES

H. LIFTING

This machine is an excavator. Use extreme caution when lifting or moving heavy loads. Use proper lifting equipment rated at a capacity to handle the load. **NEVER USE BUCKET TEETH TO LIFT OR MOVE HEAVY LOADS.**

I. FROZEN & SNOW COVERED WORK SITES

Use extreme caution when operating the machine on frozen or snow covered work sites. Operate all controls slowly and cautiously to prevent sudden movements that may cause the machine to unexpectedly shift, slide or move. Even on the slightest slope, when snow is present or work area is frozen can allow a machine to unexpectedly move. Snow on shoulders or snow drifts can be much deeper than expected. The machine can easily become buried under such conditions. Use extreme caution while operating the machine around or in snow.

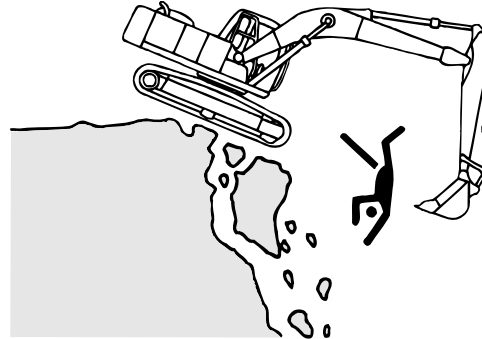

SK32001006

USE EXTREME CAUTION ON FROZEN OR SNOW

J. FILLED OR UNSTABLE GROUND

Be certain the condition of the work site is stable and capable of supporting the machine during operation. Do not operate attachment too close to the machine. Operation of the machine on shoulders or filled areas could cause the machine to become unstable presenting a work hazard. Position the travel motors to the rear of the machine, allowing for quick reversal, should the work area become unstable.

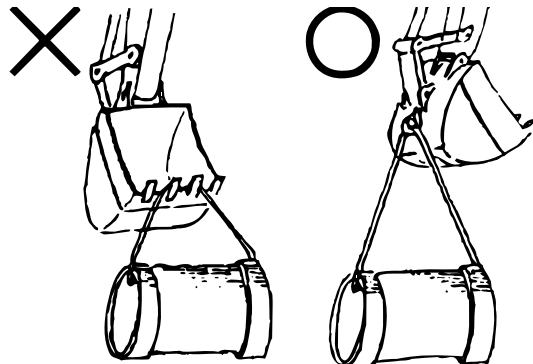

SK32001021

USE PROPER LIFTING DEVICES

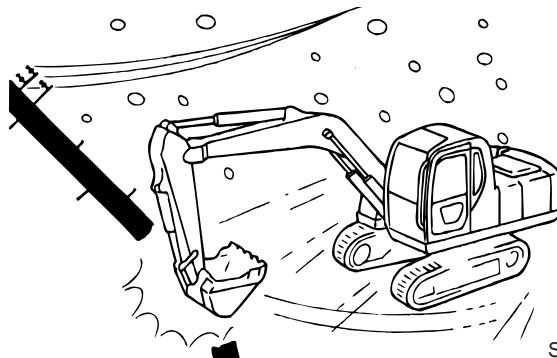

SK32001022

WORK ON STABLE GROUND

SAFETY PRECAUTIONS

K. RESTRICTED WORK AREAS

In work sites with limited height and swing areas such as tunnels, bridges, around electrical power lines, other utilities, or inside structures, use extreme caution in keeping the machine and its attachment a safe distance away to prevent personal injury and / or equipment or structure damage. Use a flagman to direct the operator.

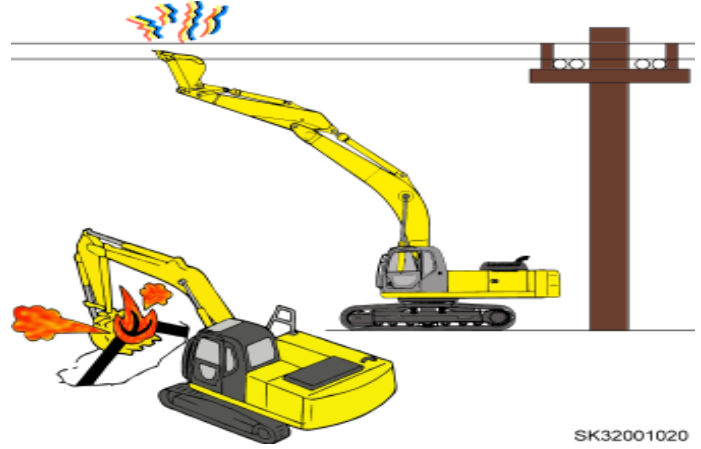

SK32001020

BE AWARE OF OBSTACLES

L. PARKING THE MACHINE

Always park the machine on a firm, level surface. If no firm level surface is available, block the tracks and lower attachment to the ground to help prevent machine movement. Should the machine be parked on a roadway, move the machine to the shoulder to allow passing of traffic. Also post reflective warning signs and markers at a distance from the machine to safely warn motorists. Refer to local code and regulations regarding the posting of work area warnings and markers.

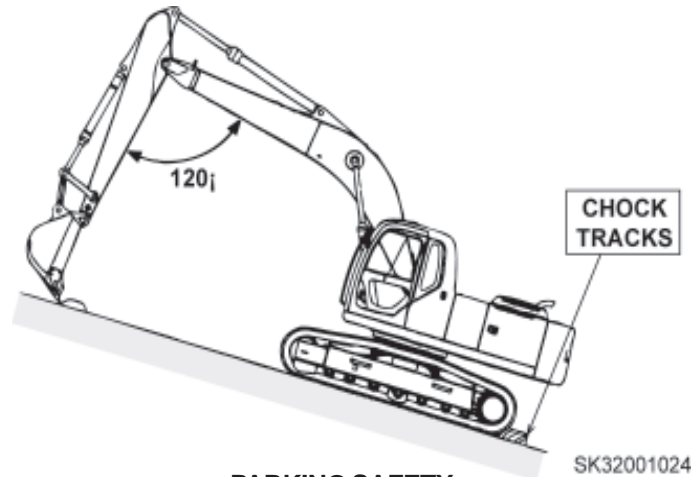

SK32001024

PARKING SAFETY

M. STABILIZE ATTACHMENTS

Stabilize all attachments removed from the machine to prevent the attachment falling over.

1.5 INSPECTION & MAINTENANCE SAFETY

A. "TAG-OUT" MACHINE

Before performing any inspection or maintenance procedures to the machine, fill out and post to the operators controls a "DO NOT OPERATE" tag to warn persons not to start the machine. Also inform the supervisor and all operators that the machine is under inspection or maintenance and they will be informed when the machine is ready for normal operation.

B. TOOLS & EQUIPMENT

Use the proper tools and equipment for the task at hand. Know the proper use of the tools and equipment before starting any inspection or maintenance procedures.



SK32001025

STABILIZE ATTACHMENTS WHEN REMOVED

C. PERSONAL EQUIPMENT

Wear well fitting work clothes, hard hat, safety shoes and gloves. Confine long hair, loose clothing and remove all jewelry before attempting any inspection or maintenance procedures to this machine or attachments.

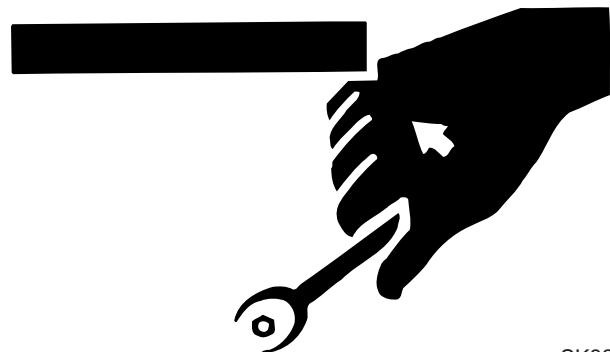

SK32001026

USE PROPER TOOLS

SAFETY PRECAUTIONS

D. STOP THE ENGINE

BE CERTAIN TO TURN ENGINE OFF AND LACE THE SAFETY LOCK LEVER IN THE "LOCKED" (UP) POSITION before attempting any inspection or maintenance procedures to the machine. Failure to stop engine could result in serious bodily injury or death.

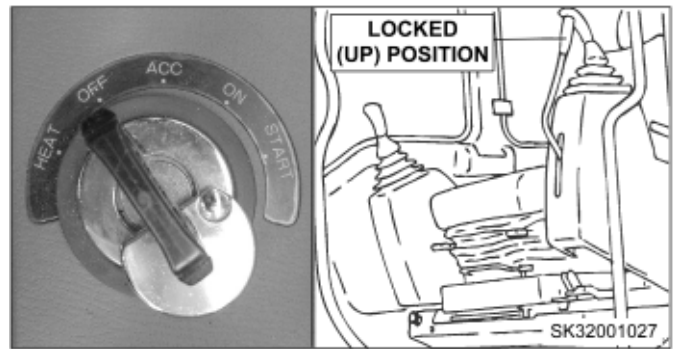

STOP ENGINE/ENGAGE SAFETY LOCK LEVER

E. SET THE ATTACHMENT

Always set the machine in the hydraulic oil check position on firm level ground before attempting any inspection or maintenance procedures to the machine. If it is not possible to put the machine in this position, secure the boom, arm and attachment to help prevent sudden movement. **ALWAYS PLACE ATTACHMENTS ON THE GROUND AND RAISE THE SAFETY LOCK LEVER BEFORE LEAVING THE CAB.**

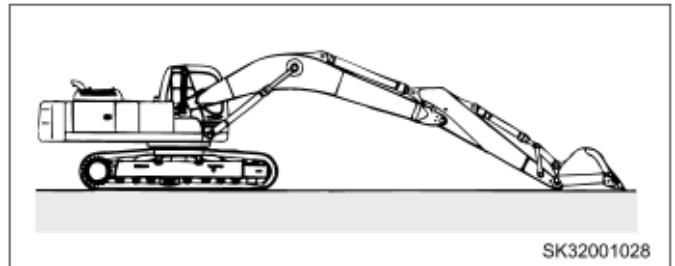

HYDRAULIC OIL CHECK POSITION

F. CLEAN THE MACHINE

Keep the machine clean and free of debris, excess or spilled lubricants, fuel and fluids. Use approved solvents, detergents and water to clean the machine and its components on a regular basis. Be careful not to allow water to reach electrical components. Serious damage can occur to the electrical system by allowing water to reach the electrical components. Never clean inside of cab, or electrical components with pressurized water or steam.

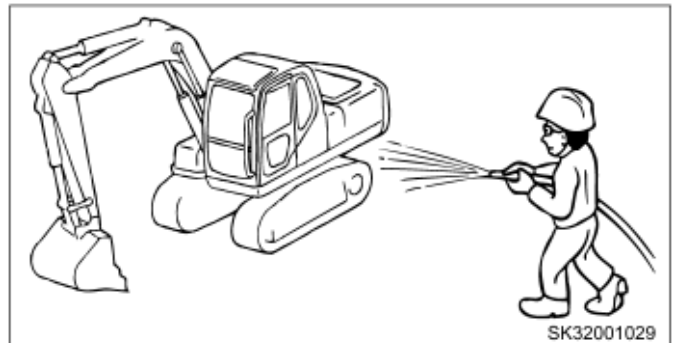

KEEP MACHINE CLEAN

G. PRESSURIZED FLUIDS & LUBRICANTS

Always release pressure from hydraulic reservoir, engine coolant, fuel system and all systems containing pressure before removing any caps or components **BE CAUTIOUS OF HOT FLUIDS AND GASSES FROM SYSTEMS ON MACHINES THAT HAVE JUST BEEN STOPPED. ALLOW SUFFICIENT TIME FOR SYSTEMS TO COOL BEFORE PERFORMING ANY INSPECTION OR MAINTENANCE PROCEDURES.**

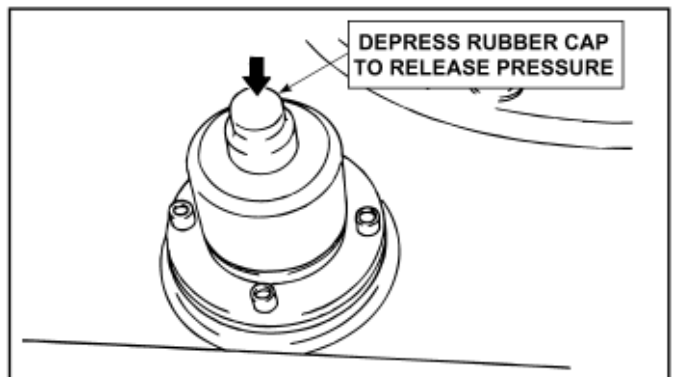

RELEASE HYDRAULIC TANK PRESSURE

H. SUPPORT THE MACHINE

If it becomes necessary to raise the machine for inspection or maintenance, always support the machine by positioning the machine as shown in the illustration and use safety supports or blocks, with a sufficient capacity rating to support the machine, under the tracks. **NEVER INSPECT OR PERFORM MAINTENANCE PROCEDURES UNDER A RAISED MACHINE THAT IS NOT SUFFICIENTLY SUPPORTED.**

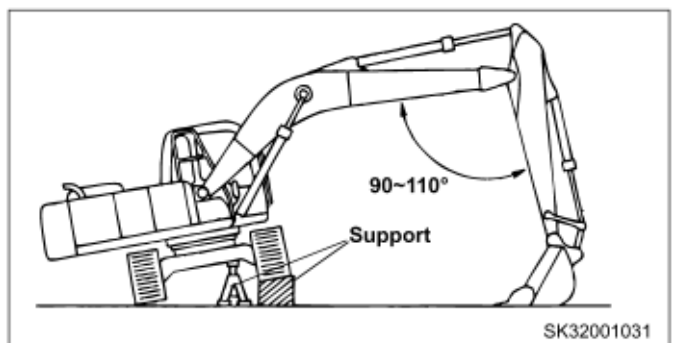

SUPPORT THE MACHINE

SAFETY PRECAUTIONS

I. REFUELING

Move the machine to a well ventilated area for refueling. Use only specified fuel as described in the MAINTENANCE section of this operators manual. Immediately clean up all spilled fuel and dispose of properly. After refueling is complete, securely tighten fuel cap.



J. HYDRAULIC PRESSURE

Under normal conditions, all circuits of the hydraulic system are under extreme pressure. When inspecting for leaks, use a small piece of cardboard, wood or metal to locate leaks. **SMALL (PINHOLE) LEAKS CAN BE DANGEROUS IF CONTACT WITH SKIN OR EYES IS MADE.** Wear approved safety glasses or face shield, gloves, hard hat, safety shoes and work clothes during all inspection and maintenance procedures.



K. TRACK SHOE TENSION

The grease used to adjust the track shoe tension is under extreme pressure in the cylinder. Use extreme caution when adjusting track shoe tension.

KEEP FACE, HANDS AND LEGS AWAY FROM THE GREASE NIPPLE AREA. Carefully and slowly loosen the grease nipple when lessening track shoe tension. Never loosen grease nipple more than one complete turn.



L. ELECTRICAL SYSTEM

Before performing any inspection or maintenance to the electrical system, or performing any welding procedures, disconnect the negative (-) cables from the battery terminals. Not disconnecting the negative (-) cable could cause extensive damage to the electrical system.

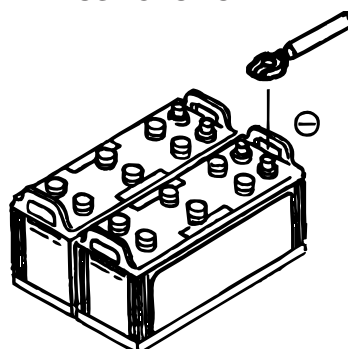

M. USE APPROVED WORK LIGHTS

Use only approved work lights when performing inspection and maintenance procedures to prevent possible fire or explosion. Certain types of work lights should not be used due to the possibility of ignition of certain flammable gasses and fluids from the machine.



N. DISPOSE OF WASTE PROPERLY

Dispose of oils, fuel, coolant, solvents, filters, batteries etc. according to federal, state and local codes and regulations regarding hazardous waste disposal. Contact Local authorities for proper disposal methods of such materials.

SAFETY PRECAUTIONS

1.6 BATTERY SAFETY

A. WEAR PROPER PROTECTIVE CLOTHES

Wear long sleeve shirt, gloves and approved safety glasses or face shield when working with or around batteries. Battery electrolyte (acid) will cause severe burns if allowed to make contact with the clothing, skin or eyes. Should electrolyte (acid) come in contact with clothes, skin or eyes, immediately remove affected clothing, flush area with clean water for 15 minutes and get prompt medical attention.

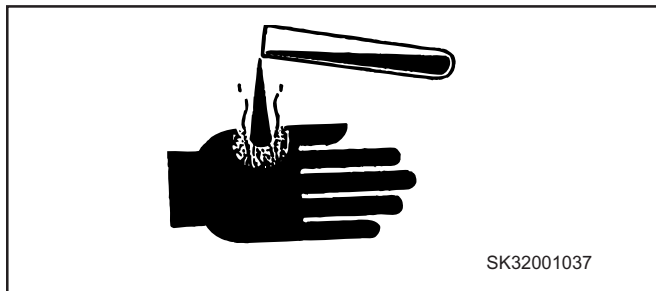

WEAR PROTECTIVE CLOTHES

B. KEEP AWAY FROM FIRE OR FLAMES

Never allow batteries in the vicinity of fire or flames and do not smoke when working with batteries. Explosive hydrogen gas is produced by the electrolyte (acid) in the batteries. Always work with batteries in a well ventilated area.

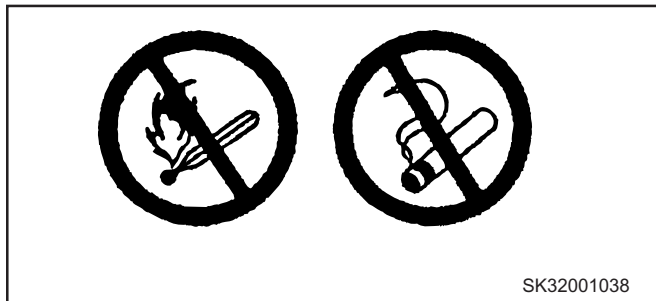

KEEP AWAY FROM FIRE OR FLAMES

C. CHARGING BATTERY

Charge battery off of and away from machine in a well ventilated area. When charging battery, remove cell covers to allow gasses to escape. Avoid breathing gasses from battery. Wear approved Safety equipment when working with batteries.

D. USING BOOSTER CABLES

Wear proper safety equipment when working with batteries.

If using another machine or vehicle to boost batteries, make certain the machine or vehicle DOES NOT touch the disabled machine.

Make certain of the positive (+) and negative (-) terminals on the booster battery and the disabled machine before connecting booster cables.

Connect the positive (+) cable first, then connect negative (-).

When disconnecting, disconnect the negative (-) cable first, then disconnect the positive (+) cable. Refer to BASIC MACHINE OPERATION Section of this manual for proper procedures for use of booster cables.

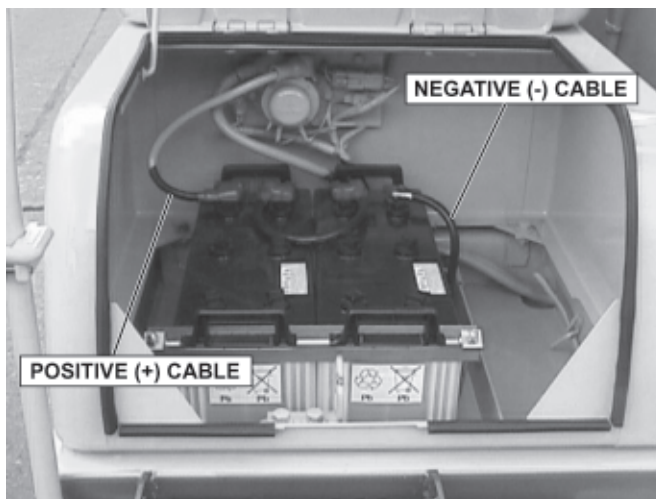

MAKE CERTAIN OF THE POSITIVE (+) AND NEGATIVE (-) TERMINALS



WARNING

Improper booster cable connections can cause an explosion resulting in personal injury.

Connect booster cables using following procedure.

1. Connect booster cable to positive (+) battery terminal of discharge battery. Connect other end of booster cable to positive battery terminal of normal battery.
2. Connect other booster cable to negative (-) battery terminal of normal battery. Connect other end of booster cable to upper frame of troubled machine.
3. Start engine and remove booster cables on reverse order.

SAFETY PRECAUTIONS

1.7 WARNING LABELS & DECALS

Warning labels and decals are affixed to the machine to remind operators and personnel specific safety precautions in certain areas of the machine. The following are illustrated examples of all warning labels and decals along with their locations.

1. SWING-DANGER

Located on each side of the rear counterweight.
Part Number – YN20T01003P2 (2REQ'D)



2. PRESSURIZED HOT OIL – WARNING

Located on top of Hydraulic Tank.
Part Number – YN20T01289P1

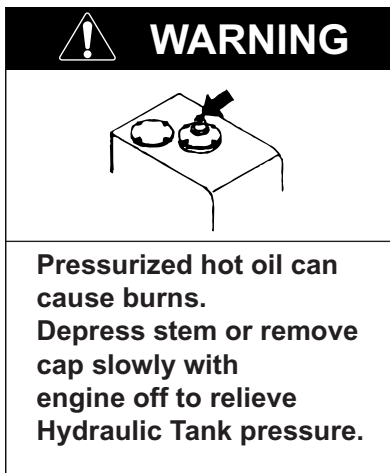

3. BATTERY – DANGER /POISON

Located on Battery



4. STOP ENGINE-WARNING

Located on top of engine fan shroud.
Part Number– YN20T01009P1



5. BOOSTER CABLE-WARNING

Located on battery box compartment.
Part Number– YN20T01015P2

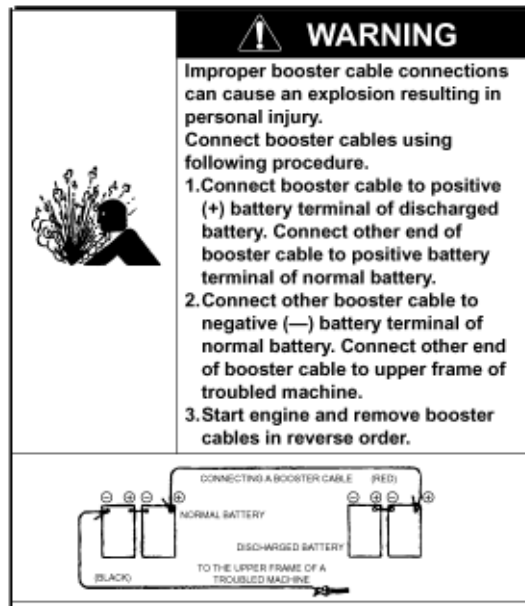

SAFETY PRECAUTIONS

6. ACCUMULATOR CONTAINS PRESSURIZED GAS– WARNING

Located on side of nitrogen accumulator
Part Number– YN20T01216P1

WARNING

ACCUMULATOR CONTAINS PRESSURIZED GAS.

- Do not disassemble.
- Do not remove plug in service.
- Do not dispose without relieving gas loosening plug.

YN20T01216P1

7. BOOSTER CABLE – WARNING

Located on battery box access compartment.
Part Number – YN20T01338P1

WARNING

Electric hazard may cause injury when mishandling the cable.

Read operator manual for safe and proper handling.

8. POWER BOOST SWITCH– WARNING

Located inside cab on R.H. Window.
Part Number– YN20T01004P1

WARNING

Releasing power boost switch while lifting a load can cause unexpected lowering of load, resulting severe injury or death.

Never use power boost switch of lifting a load.

9. HEAVY LIFT SWITCH– WARNING

Located inside cab on R.H. Window.
Part Number– YN20T01340P1

WARNING

Turning off heavy lift switch while lifting a load can cause unexpected lowering of load, resulting in severe injury or death.

Never turn off heavy lift switch while lifting a load.

YN20T01340P1

10. ELECTRICAL POWER LINES– WARNING

Located inside cab on R.H. Panel.
Part Number– YN20T01006P1

WARNING

Contact with electrical power lines will result in severe injury or death.

Keep machine and attachment a safe distance from electrical power lines as per following instruction.

VOLTAGE (Volts)	SAFETY DISTANCE
50K OR LESS	3.0M (10FT)
50K TO 200K	4.5M (15FT)
200K TO 350K	6.0M (20FT)
350K TO 500K	7.5M (25FT)
500K TO 750K	10.5M (35FT)
750K OR OVER	13.5M (45FT)

YN20T01006P1

11. DO NOT LIFT MACHINE THROUGH COUNTERWEIGHT LIFTING EYES - DANGER

Located on top of counterweight. (2 Required)
Part Number– YN20T01221P1

DANGER

Do not use counterweight lifting eyes to lift whole machine.

Lifting eyes can fall under this load resulting in personal injury.

Refer to operators manual for proper way of lifting machine.

YN20T01221P1

12. DO NOT STEP ON – WARNING

Located on top of engine cover.
Part Number– 2432P3055



SAFETY PRECAUTIONS

13. HOT COOLANT – WARNING

Located on top of engine fan shroud.
Part Number– YN20T01010P1

WARNING

Steam of hot coolant can cause injury or blindness.

Never loosen or open radiator cap when coolant is hot and under pressure.

Before opening radiator cap:

- Cool Down engine completely.
- Cover radiator with cloth rag.
- Loosen cap slowly to relieve pressure.

YN20T01010P1

14. HOT PARTS – CAUTION

Located on top of engine cover.
Part Number– YN20T01220P1

CAUTION



Engine may be hot which could cause burns.

Do not touch engine until it cools down.

YN20T01220P1

15. ROTATING PARTS - CAUTION

Located on top of engine cover
Part Number– YN20T01012P1

CAUTION

Rotating engine fan, hot engine parts and drive belt can cause severe injury.

Do not open engine cover with engine running.

YN20T01012P1

16. USE DIESEL FUEL

Located on side of fuel tank opening.
Part Number– YN20T01213P1



17. GREASE SWING BEARING

Located on upper frame lower right corner - Below cab. Part Number– 2432P2689



18. ANTIFREEZE SOLUTION

Located on back side of radiator compartment door.
Part Number– YN20T01097P1



19. HYDRAULIC OIL CHECK POSITION

Located on back side of pump compartment door.
Part Number– 2432P3379

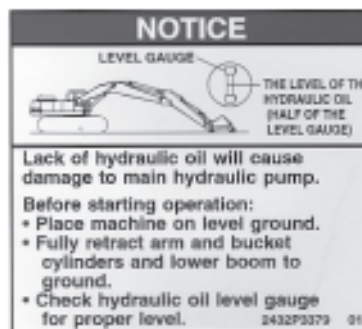

20. HYDRAULIC OIL USED

Located on the back side of hydraulic tank.
Part Number– 2432T6573

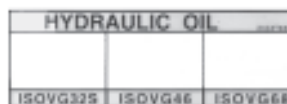

21. SERIAL NUMBER PLATE

Located on upper frame lower right corner - Below cab. Part Number– 2432T5613

