



**WVNAVY**

**[HTTP://WWW.WVNAVY.COM](http://www.wvnavy.com)**

**Click on the web address above to go to our website.**

**TECHNICAL MANUAL**

**DIRECT SUPPORT AND GENERAL SUPPORT  
MAINTENANCE MANUAL**

**FOR**

**TRACTOR, WHEELED,  
DED, LOADER BACKHOE:  
WITH HYDRAULIC IMPACT TOOL AND  
WITH HYDRAULIC EARTH AUGER ATTACHMENT  
JOHN DEERE MODEL JD410 (CCE)  
WITH BUCKET, IMPACTOR,  
AND EARTH DRILL  
(NSN 2420-00-567-0135)**

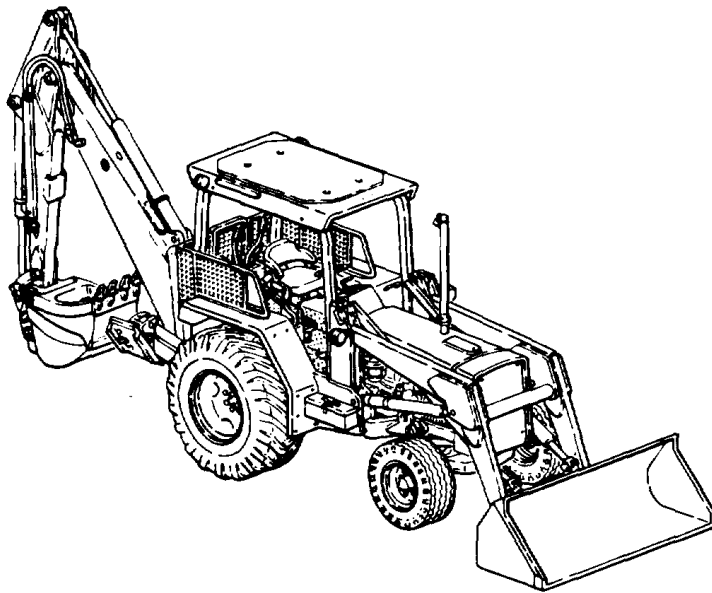

|  |      |
|--|------|
| Troubleshooting                            | 2-1  |
| Engine Assembly                            | 3-1  |
| Clutch Assembly                            | 4-1  |
| Fuel System                                | 5-1  |
| Transmission                               | 8-1  |
| Front and Rear Axles                       | 9-1  |
| Brake System                               | 10-1 |
| Steering System                            | 11-1 |
| Body and Accessories                       | 13-1 |
| Hydraulic System                           | 14-1 |
| Cranes, Shovels, and Earthmoving Equipment | 15-1 |
| Appendices                                 | A-1  |

This manual and LO 5-2420-222-12, TM 5-2420-222-20P, and TM 5-2420-222-34P supersede TM 5-2420-222-14&P-1, dated 1 January 1987, and TM 5-2420-222-14&P-2, dated 1 November 1986, including all changes.

Approved for public release; distribution is unlimited.

HEADQUARTERS, DEPARTMENT OF THE ARMY

26 AUGUST 1992

**FOR INFORMATION ON FIRST AID, REFER TO FM 21-11.**

**WARNING**

**CARBON MONOXIDE EXHAUST GASES CAN KILL!**

Carbon monoxide is a colorless, odorless, deadly poisonous gas which, when breathed, deprives the body of oxygen and causes suffocation. Exposure to air containing carbon monoxide produces symptoms of headache, dizziness, loss of muscular control, apparent drowsiness, and coma. Permanent brain damage or death can result from severe exposure.

Carbon monoxide occurs in exhaust fumes of internal combustion engines. Carbon monoxide can become dangerously concentrated under conditions of inadequate ventilation. The following precautions must be observed to ensure safety of personnel when engine of loader backhoe is operated for any purpose.

- (1) DO NOT operate loader backhoe engine in enclosed areas.
- (2) DO NOT idle loader backhoe engine without ventilator blower operating.
- (3) BE ALERT at all times for exhaust odors.
- (4) BE ALERT for exhaust poisoning symptoms. They are:
  - Headache
  - Dizziness
  - Sleepiness
  - Loss of muscular control
- (5) If you see another person with exhaust poisoning symptoms:
  - Remove person from area.
  - Expose to fresh air.
  - Keep person warm.
  - Do not permit physical exercise.
  - Administer artificial respiration, if necessary.
  - Notify a medic.
- (6) BE AWARE: The field protective mask for chemical-biological-radiological (CBR) protection will not protect you from carbon monoxide poisoning.

**The Best Defense Against Carbon Monoxide Poisoning Is Good Ventilation.**

**WARNING****ASBESTOS HAZARD**

DO NOT handle clutch assembly components unless area has been properly cleaned. There may be asbestos dust on these components which can be dangerous if you touch it or breathe it. Wear an approved filter mask and gloves. Never use compressed air or a dry brush to clean clutch assembly components. Dust may be removed using an Industrial-type vacuum cleaner. Clean dust or mud away from brake components with water and a wet, soft brush or cloth. Failure to follow this warning may result in serious illness or death to personnel.

**WARNING****CLEANING AGENTS**

- Dry cleaning solvent, P-D-680, is toxic and flammable. Always wear protective goggles and gloves, and use only in a well-ventilated area. Avoid contact with skin, eyes, and clothes, and DO NOT breathe vapors. DO NOT use near open flame or excessive heat. The solvent's flash point is 100°F-138 F (38° C-59° C). If you become dizzy while using cleaning solvent, immediately get fresh air and medical help. If solvent contacts eyes, immediately wash your eyes and get medical aid.
- Cleaning compound, trichlorotrifluoroethane, for electrical parts is toxic and flammable, and reacts violently with aluminum, titanium, barium, lithium, samarium, sodium, and potassium. Always wear protective goggles and rubber gloves, and use only in a well-ventilated area. DO NOT wear jewelry while using cleaning compound. Avoid contact with skin, eyes, and clothes, and DO NOT breathe vapors. Cleaning compound fumes or vapors can take the place of air and may become a cancer producing agent. DO NOT use near open flame or excessive heat. The compound's boiling point is 114°F (46° C). If you become dizzy while using cleaning compound, immediately get fresh air and medical help. If compound contacts eyes, immediately wash your eyes with water and get medical aid.
- Denatured alcohol is highly flammable and poisonous. Drinking this alcohol can cause blindness and death. Avoid inhaling its fumes. Keep away from open flames. Failure to follow this warning may result in serious injury or death to personnel.

**WARNING****COMPRESSED AIR**

Compressed air used for cleaning or drying purposes, or for clearing restrictions, should never exceed 30 psi (207 kPa). Wear protective clothing (goggles/shield, gloves, etc.) and use caution to avoid injury to personnel.

**WARNING****ELECTRICAL SYSTEM**

- When troubleshooting an electrical malfunction or performing electrical maintenance, ALWAYS disconnect the battery cables. Failure to do so may result in injury or death due to electric shock.
- Battery acid (electrolyte) is extremely dangerous. Use care when removing battery caps. Serious injury to personnel may result if battery acid contacts skin or eyes.

**WARNING****HANDLING HEAVY COMPONENTS**

Use extreme caution when handling heavy parts. Lifting device is required when parts weigh over 50 lb (23 kg) for a single person lift, over 100 lb (45 kg) for a two person lift, and over 150 lb (68 kg) for a three or more person lift. Keep clear of heavy parts supported only by lifting device. Failure to follow this warning may cause serious injury or death to personnel.

**WARNING****LIVE STEAM**

Avoid contact with live steam. Live steam can burn skin, cause blindness, and other serious injury. Be sure to wear protective apron, gloves, and safety goggles when using live steam.

**WARNING****NBC HAZARD**

If NBC exposure is suspected, all engine air cleaner air filter media should be handled by personnel wearing protective equipment. Consult your NBC Officer or NBC NCO for appropriate handling or disposal procedures.

**c/(d Blank)**

**DIRECT SUPPORT AND GENERAL SUPPORT  
MAINTENANCE MANUAL**

**FOR**

**TRACTOR, WHEELED,  
DED, LOADER BACKHOE:  
WITH HYDRAULIC IMPACT TOOL AND  
WITH HYDRAULIC EARTH AUGER ATTACHMENT  
JOHN DEERE MODEL JD410 (CCE)  
WITH BUCKET, IMPACTOR,  
AND EARTH DRILL  
(NSN 2420-00-567-0135)**

**REPORTING ERRORS AND RECOMMENDING IMPROVEMENTS**

You can help improve this manual. If you find any mistakes or if you know of a way to improve the procedures, please let us know. Mail your letter, DA Form 2028 (Recommended Changes to Publications and Blank Forms), or DA Form 2028-2, located in the back of this manual, direct to: Commander, U.S. Army Tank-Automotive Command, ATTN: AMSTA-MB, Warren, MI 48397-5000. A reply will be furnished to you.

**TABLE OF CONTENTS**

|  | Page  |
|--|-------|
| How To Use This Manual .....   | iii   |
| <b>CHAPTER 1 INTRODUCTION</b>  |       |
| Section I.    General Information .....  | 1-1   |
| Section II.   Equipment Description and Data .....   | 1-2   |
| Section III.  Repair Parts; Special Tools; Test, Measurement,<br>and Diagnostic Equipment (TMDE); and Support Equipment..... | 1-3   |
| Section IV.  General Maintenance Instructions .....  | 1-4   |
| <b>CHAPTER 2</b> <b>TRROUBLESHOOTING PROCEDURES</b> .....  | 2-1   |
| <b>CHAPTER 3</b> <b>ENGINE ASSEMBLY MAINTENANCE</b>  |       |
| Section I.    Engine Assembly Maintenance .....  | 3-1   |
| Section II.   Lubrication System Maintenance .....   | 3-115 |

\*This manual and LO 5-2420-222-12, TM 5-2420-222-10, TM 5-2420-222-20-1, -20-2, -20-3, TM 5-2420-222-20P, and TM 5-2420-222-34P supersede TM 5-2420-222-14&P-1, dated 1 January 1987, and TM 5-2420-222-14&P-2, dated 1 November 1 1986, including all changes.

Approved for public release; distribution is unlimited.

TABLE OF CONTENTS (CON'T)

|   | Page    |
|---|---------|
| CHAPTER 4 <b>CLUTCH ASSEMBLY MAINTENANCE</b> .....                                      | 4-1     |
| CHAPTER 5 <b>FUEL SYSTEM MAINTENANCE</b> .....  | 5-1     |
| CHAPTER 6 <b>COOLING SYSTEM MAINTENANCE</b> .....                                       | 6-1     |
| CHAPTER 7 <b>ELECTRICAL SYSTEM MAINTENANCE</b> .....                                    | 7-1     |
| CHAPTER 8 <b>TRANSMISSION MAINTENANCE</b> .....   | 8-1     |
| CHAPTER 9 <b>AXLE MAINTENANCE</b>   |         |
| Section I.    Front Axle Maintenance .....  | 9-1     |
| Section II.   Rear Axle Maintenance .....   | 9-10    |
| CHAPTER 10 <b>BRAKE SYSTEM MAINTENANCE</b> .....  | 10-1    |
| CHAPTER 11 <b>STEERING SYSTEM MAINTENANCE</b> .....                                     | 11-1    |
| CHAPTER 12 <b>FRAME MAINTENANCE</b> .....   | 12-1    |
| CHAPTER 13 <b>BODY AND ACCESSORIES MAINTENANCE</b> .....                                | 13-1    |
| CHAPTER 14 <b>HYDRAULIC SYSTEM MAINTENANCE</b> .....                                    | 14-1    |
| CHAPTER 15 <b>CRANES, SHOVELS, AND EARTHMOVING EQUIPMENT<br/>COMPONENTS MAINTENANCE</b> |         |
| Section I.    Backhoe Assembly Maintenance .....  | 15-1    |
| Section II.   Loader Assembly Maintenance .....   | 15-22   |
| CHAPTER 16 <b>PARTS PECULIAR MAINTENANCE</b> .....                                      | 16-1    |
| APPENDIX A <b>REFERENCES</b> .....  | A-1     |
| APPENDIX B <b>EXPENDABLE/DURABLE SUPPLIES AND MATERIALS LIST</b> .....                  | B-1     |
| APPENDIX C <b>ILLUSTRATED LIST OF MANUFACTURED ITEMS</b> .....                          | C-1     |
| APPENDIX D <b>TORQUE LIMITS</b> .....   | D-1     |
| INDEX .....   | Index-1 |

## HOW TO USE THIS MANUAL

This manual is designed to help maintain the John Deere Model JD410 Wheeled Tractor Loader Backhoe. This manual describes in detail the Direct Support and General Support Maintenance prescribed by the Maintenance Allocation Chart (see TM 5-2420-222-20) and Source, Maintenance, and Recoverability (SMR) Codes (see TM 5-2420-222-34P).

### FEATURES OF THIS MANUAL:

- Bleed-to-edge indicators on the cover and on the edge of the applicable manual pages provide quick access to chapters most often used.
- A table of contents is provided for all chapters and sections.
- WARNINGS, CAUTIONS, NOTES, subject headings, and other important information are highlighted in bold print as visual aids.
- Statements and words of particular importance are printed in capital letters to create emphasis.
- Instructions are located together with illustrations that show the specific task or, which the technician is working
- An alphabetical index is provided at the end of the manual to assist in locating information not readily found in the table of contents.
- Technical instructions include metric units in addition to standard units. A metric conversion chart is provided on the inside back cover.

### FOLLOW THESE GUIDELINES WHEN YOU USE THE MANUAL:

- Read through this manual and become familiar with its contents before proceeding to specific maintenance warning summary is provided at the beginning of this manual and should be read before performing any maintenance tasks.
- In the actual maintenance tasks, follow all WARNINGS, CAUTIONS, and NOTES. These are given immediately preceding the procedural steps to which they apply. If these instructions are not followed or care is not taken, injury to personnel or equipment damage may result.
- Within a chapter, section, or paragraph, headings are used to help group the material and assist in quickly finding tasks. Read all preliminary information found at the beginning of each task. After completing a task, ALWAYS perform the follow-on maintenance at the end of the task.



CHAPTER 1  
INTRODUCTION

Section I. GENERAL INFORMATION

| Paragraph Number | Paragraph Title  | Page Number |
|------------------|--|-------------|
| 1-1              | Scope .....  | 1-1         |
| 1-2              | Maintenance Forms, Records, and Reports .....                | 1-1         |
| 1-3              | Destruction of Army Materiel To Prevent Enemy Use.....       | 1-1         |
| 1-4              | Reporting Equipment Improvement Recommendations (EIRs) ..... | 1-1         |

**1-1. SCOPE.**

This manual describes the troubleshooting and maintenance of the John Deere Model JD410 Wheeled Tractor Loader Backhoe for Direct Support and General Support Maintenance mechanics.

**1-2. MAINTENANCE FORMS, RECORDS, AND REPORTS.**

Department of the Army forms and procedures used for equipment maintenance will be those prescribed by DA Pam 738-750, The Army Maintenance Management System (TAMMS).

**1-3. DESTRUCTION OF ARMY MATERIEL TO PREVENT ENEMY USE.**

For destruction of Army materiel to prevent enemy use, refer to TM 750-244-3.

**1-4. REPORTING EQUIPMENT IMPROVEMENT RECOMMENDATIONS (EIRs).**

If your loader backhoe needs improvement, let us know. Send us an EIR. You, the user, are the only one who can tell us what you don't like about your equipment. Let us know why you don't like the design. Put it on an SF Form 368 (Product Quality Deficiency Report). Mail it to us at: Commander, U.S. Army Tank-Automotive Command, ATTN: AMSTA-MP, Warren, MI 48397-5000. We'll send you a reply.

Section II. EQUIPMENT DESCRIPTION AND DATA

| Paragraph Number | Paragraph Title                  | Page Number |
|------------------|----------------------------------|-------------|
| 1-5              | Differences Between Models ..... | 1-2         |
| 1-6              | Equipment Data .....             | 1-2         |

**1-5. DIFFERENCES BETWEEN MODELS.**

**WARNING**

**Pay close attention to serial numbers when performing maintenance on this equipment. Installation of Incorrect part numbers may result in injury to personnel or damage to equipment.**

Although all loader backhoes covered in this manual have the same model number, there are differences in configuration depending on the loader backhoe serial number. The two serial number breaks are 235786-235999 and 319995-342573. These two configurations differ primarily in transmission design and hydraulic line routing. Throughout this manual, where differences in configuration or equipment affect the maintenance, they are shown in detail. If the differences are minor or obvious, such as differences in exact appearance or location, and maintenance is not affected, typical equipment is shown.

**1-6. EQUIPMENT DATA.**

Refer to TM 5-2420-222-10 for information on loader backhoe identification and data plates, major components, and end item and component specifications.

**Section III. REPAIR PARTS; SPECIAL TOOLS;  
TEST, MEASUREMENT, AND DIAGNOSTIC EQUIPMENT (TMDE);  
AND SUPPORT EQUIPMENT**

| Paragraph Number | Paragraph Title  | Page Number |
|------------------|--|-------------|
| 1-7              | Common Tools .....   | 1-3         |
| 1-8              | Special Tools; Test, Measurement, and Diagnostic Equipment (TMDE);<br>and Support Equipment..... | 1-3         |
| 1-9              | Repair Parts .....   | 1-3         |

**1-7. COMMON TOOLS.**

For authorized common tools and test equipment, refer to the Modified Table of Organization and Equipment (MTOE) applicable to your loader backhoe.

**1-8. SPECIALTOOLS; TEST, MEASUREMENT, AND DIAGNOSTIC EQUIPMENT (TMDE); AND SUPPORT EQUIPMENT.**

Special tools required for maintenance of the loader backhoe are listed in TM 5-2420-222-34P. Refer to the Maintenance Allocation Chart (MAC) in TM 5-2420-222-20 for a description of necessary tools, TMDE, and support equipment. Refer to Appendix C, Illustrated List of Manufactured Items, in this manual for a description of fabricated tools.

**1-9. REPAIR PARTS.**

Repair parts for the Direct Support and General Support Maintenance of the loader backhoe are listed and illustrated in TM 5-2420-222-34P.

## Section IV. GENERAL MAINTENANCE INSTRUCTIONS

| Paragraph Number | Paragraph Title                                      | Page Number |
|------------------|--|-------------|
| 1-10             | General.....   | 1-4         |
| 1-11             | Work Safety.....                                     | 1-5         |
| 1-12             | Cleaning Instructions.....                           | 1-5         |
| 1-13             | Preservation of Parts.....                           | 1-6         |
| 1-14             | Painting.....  | 1-6         |
| 1-15             | Inspection Instructions.....                         | 1-6         |
| 1-16             | Bearing Clearance Gage.....                          | 1-7         |
| 1-17             | Service Replacement Kits.....                        | 1-8         |
| 1-18             | Tagging Parts.....                                   | 1-8         |
| 1-19             | Soldering.....                                       | 1-9         |
| 1-20             | Heat Shrink Tubing.....                              | 1-9         |
| 1-21             | Wire Terminal Lug and Connector Replacement.....     | 1-10        |
| 1-22             | Wire Replacement.....                                | 1-10        |
| 1-23             | Wiring Harness Connector Repair and Replacement..... | 1-11        |
| 1-24             | Electrical Ground Points.....                        | 1-12        |
| 1-25             | Lines and Ports.....                                 | 1-13        |
| 1-26             | Antiseizing Tape.....                                | 1-13        |
| 1-27             | Tubes and Compression Fittings.....                  | 1-13        |
| 1-28             | Lockwire.....  | 1-14        |
| 1-29             | Fluid Disposal.....                                  | 1-15        |

**1.10. GENERAL.**

a. These general maintenance instructions contain general shop practices and specific methods you must be familiar with to properly maintain your loader backhoe. You should read and understand these practices and methods before performing any Direct Support and General Support Maintenance procedures.

b. Before beginning a task, find out how much repair, modification, or replacement is needed to fix the equipment. Sometimes the reason for equipment failure can be seen right away and complete teardown is not necessary. Disassemble equipment only as far as necessary to repair or replace damaged parts.

c. In some cases, a part may be damaged by removal. If the part appears to be good, and other parts behind it are not defective, leave it on and continue with the procedure. Here are a few simple rules:

(1) Do not remove dowel pins or studs unless loose, bent, broken, or otherwise damaged.

(2) Do not remove bearings or bushings unless damaged. If you need to remove them to access parts behind, pull bearings and bushings out carefully.

(3) Replace all gaskets, lockwashers, seals, cotter pins, and preformed packings.

d. The following "Initial Setup" information applies to all procedures:

(1) Resources are not listed unless they apply to the procedure.

(2) "Personnel Required" is listed only if more than one mechanic is required to complete the task.

---

**1-10. GENERAL (Con't).**

---

e. All tags and forms attached to equipment must be checked to learn the reason for removal of equipment from service. Modification Work Orders (MWO) and Technical Bulletins (TB) must also be checked for equipment changes and updates.

---

**1-11. WORK SAFETY.**

---

a. Before beginning a procedure, think about the safety risks and hazards to yourself and others. Wear protective gear such as safety goggles or lenses, safety shoes, rubber apron, or gloves.

b. Immediately clean up spilled fluids to avoid slipping.

c. When lifting heavy parts, have someone help you. Ensure that lifting equipment or jack is working properly, that it meets weight requirement of part being lifted, and that it is securely fastened to part.

d. Always use power tools carefully.

e. Observe all WARNINGS and CAUTIONS.

---

**1-12. CLEANING INSTRUCTIONS.**

---

**WARNING**

**Improper cleaning methods and use of unauthorized cleaning liquids or solvents can injure personnel and damage equipment. To prevent this, refer to TM 9-247 for further instructions.**

a. **General.** Cleaning instructions will be the same for the majority of parts and components which make up the loader backhoe. The following applies to all cleaning operations:

(1) Clean all parts before inspection, after repair, and before assembly.

(2) Keep hands free of grease which can collect dust, dirt, and grit.

(3) After cleaning, all parts should be covered or wrapped to protect them from dust and dirt. Parts that are subject to rust should be lightly oiled.

b. **Steam Cleaning.**

(1) Before steam cleaning loader backhoe, protect all electrical equipment which could be damaged by steam or moisture.

(2) Place disassembled parts in a suitable container to steam clean. Parts that are subject to rust should be dried and lightly oiled after cleaning.

c. **Castings, Forgings, and Machined Metal Parts.**

**WARNING**

**Dry cleaning solvent, P-D-680, is toxic and flammable. Always wear protective goggles and gloves, and use only in a well-ventilated area. Avoid contact with skin, eyes, and clothes, and DO NOT breathe vapors. DO NOT use near open flame or excessive heat. The solvent's flash point is 100°F-138°F (38°C-59°C). If you become dizzy while using cleaning solvent, immediately get fresh air and medical help. If solvent contacts eyes, immediately wash your eyes and get medical aid.**

(1) Clean inner and outer surfaces with dry cleaning solvent (Item 31, Appendix B).

---

**1-12. CLEANING INSTRUCTIONS (Con't).**

---

- (2) Remove grease and accumulated deposits with a scrub brush (Item 3, Appendix B).

**WARNING**

**Compressed air used for cleaning or drying purposes, or for clearing restrictions, should never exceed 30 psi (207 kPa). Wear protective clothing (goggles/shield, gloves, etc.) and use caution to avoid injury to personnel.**

- (3) Clear all threaded holes with compressed air to remove dirt and cleaning fluids.

**CAUTION**

**Do not wash oil seals, electrical cables, and flexible hoses with dry cleaning solvent or mineral spirits. Serious damage or destruction of material will result.**

- d. **Oil Seals, Electrical Cables, and Flexible Hoses.** Wash oil seals, electrical cables, and flexible hoses with a solution of detergent (Item 13, Appendix B) and water and wipe dry.
- e. **Bearings.** Clean bearings in accordance with TM 9-214.
- f. **General Cleaning Covered by Other Manuals.**
- (1) TB 43-0212, Purging, Cleaning and Coating Interior Ferrous and Terne Sheet Vehicle Fuel Tanks.
- (2) TB 750-1047, Elimination of Combustibles from Interiors of Metal or Plastic Gasoline and Diesel Fuel Tanks.
- (3) TM 9-247, Materials Used for Cleaning, Preserving, Abrading, and Cementing Ordnance Materiel and Related Items Including Chemicals.

---

**1-13. PRESERVATION OF PARTS.**

---

Unpainted metal parts that will not be installed immediately after cleaning may be covered with a thin coat of engine oil (Item 25, Appendix B).

---

**1-14. PAINTING.**

---

On painted areas where paint has been removed, paint in accordance with procedures outlined in TM 43-0139 and TB 43-0209. For camouflage painting instructions refer to TC 5-200.

---

**1-15. INSPECTION INSTRUCTIONS.**

---

**NOTE**

**All damaged areas should be marked for repair or replacement.**

- a. All components and parts must be carefully checked to determine if they are serviceable for use, can be repaired, or must be scrapped.
- b. Inspect drilled and tapped (threaded) holes for the following:
- (1) Wear, distortion, cracks, and any other damage in or around holes.
- (2) Threaded areas for wear distortion (stretching) and evidence of cross-threading.

**1-15. INSPECTION INSTRUCTIONS (Con't).**

- c. Inspect metal lines, flexible lines (hoses), and metal fittings and connectors for the following:
  - (1) Metal lines for sharp kinks, cracks, bad bends, and dents.
  - (2) Flexible lines for fraying, evidence of leakage, and loose metal fittings or connectors.
  - (3) Metal fittings and connectors for thread damage and worn or rounded hex heads.
- d. Inspect castings, forgings, and machined metal parts for the following:
  - (1) Machined surfaces for nicks, burrs, raised metal wear, and other damage.
  - (2) Inner and outer surfaces for breaks and cracks.
- e. Inspect bearings in accordance with TM 9-214.

**1-16. BEARING CLEARANCE GAGE.**

- a. A soft plastic bearing clearance gage (plastigage) squeezed between parts such as a crankshaft journal and a connecting rod or main bearing may be used to measure clearance between them.
- b. The bearing clearance gage is a specially molded plastic "wire" and is available in three measuring ranges and colors:

|              |   |
|--------------|---|
| PG-1 (Green) | 0.001-0.003 in. (0.0254-0.0762 mm)<br>(Item 19, Appendix B) |
| PR-1 (Red)   | 0.002-0.006 in. (0.0508-0.1524 mm)<br>(Item 20, Appendix B) |
| PB-1 (Blue)  | 0.004-0.009 in. (0.1016-0.2286 mm)<br>(Item 18, Appendix B) |

- c. Check bearing clearance as follows:
  - (1) Remove bearing cap and wipe oil from bearing shell and crankshaft journal.

**NOTE**

**When checking main bearing clearance with engine in position and main bearing caps supporting weight of crankshaft and flywheel, a bad reading may result due to weight of crankshaft and flywheel. To avoid a bad reading, support weight with a Jack placed under counterweight next to bearing being checked.**

- (2) Place bearing clearance gage full width of bearing shell, about y in. (6 mm) off-center.
- (3) Rotate crankshaft about 300 from bottom dead center (BDC) and install assembled bearing shell and cap. Tighten screws to specified torque.

**1-16. BEARING CLEARANCE GAGE (Con't)**

(4) Remove bearing shell and cap. Flattened gage will remain stuck to either bearing shell or crankshaft.

(5) Compare width of flattened gage at its widest point with graduations on envelope. Number within graduation on envelope indicates bearing clearance in thousandths of an inch.

(6) Taper may be indicated when one end of flattened gage is wider than the other. Measure each end of gage; the difference between readings is the approximate amount of taper.

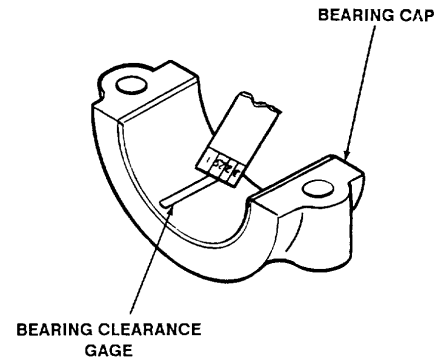
**1-17. SERVICE REPLACEMENT KITS.**

Many service replacement parts are available in various undersize and/or oversize, as well as standard sizes. Service kits for reconditioning certain parts and service sets which include all parts necessary to complete task are also available.

**1-18. TAGGING PARTS.**

a. Use marker tags (Item 32, Appendix B) to identify all electrical wires, hydraulic, fuel, oil, and coolant lines, and any other parts which may be hard to identify or replace later. Fasten tags to parts during removal by wrapping wire fasteners around or through parts and twisting ends together. Position tags to be out of the way during cleaning, inspection, and repair. Mark tags with a pencil, pen, or marker.

b. Whenever possible, identify electrical wires with number of terminal or wire to which it connects. If no markings can be found, tag both wires or wire and terminal, and use same identifying mark for both. If you cannot tag wire because it must fit through small hole or you cannot reach it, write down description of wire and the point to which it connects or draw a simple diagram on paper. Be sure to write down enough information so you will be able to connect wires properly during assembly. If you need to identify loose wire, look for identifying numbers near end of wire, stamped on a permanent metal tag. Compare this number to wire numbers on appropriate electrical schematic in TM 5-2420-222-20.

c. Identify hydraulic, fuel, oil, and coolant lines whenever you are taking off more than one line at the same time. Mark tags with points to which lines and hoses must be connected. For example: "Bulkhead adapter to scarifier cylinder tube and adapter" might be written on tag for hydraulic hose. If it is not obvious which end of a line goes where, tag each end of line.

d. Identify and tag other parts as required by name and installed location.

TA701214



---

**1-19. SOLDERING.**

---

**WARNING**

Cleaning compound, trichlorotrifluoroethane, for electrical parts is toxic and flammable, and reacts violently with aluminum, titanium, barium, lithium, samarium, sodium, and potassium. Always wear protective goggles and rubber gloves, and use only in a well-ventilated area. DO NOT wear jewelry while using cleaning compound. Avoid contact with skin, eyes, and clothes, and DO NOT breathe vapors. Cleaning compound fumes or vapors can take the place of air and may become a cancer producing agent. DO NOT use near open flame or excessive heat. The compound's boiling point is 114°F (46°C). If you become dizzy while using cleaning compound, immediately get fresh air and medical help. If compound contacts eyes, immediately wash your eyes with water and get medical aid.

**CAUTION**

Use low-wattage soldering gun when soldering electrical wires, connectors, terminal lugs, and receptacles. High-wattage soldering guns may damage parts by overheating them.

a. Solder connection must be bright and clean before soldering. Take off dirt and grease with trichlorotrifluoroethane (Item 40, Appendix B). Solder used must be tin alloy (Item 30, Appendix B) with rosin flux (Item 16, Appendix B). All wires, parts, and soldering gun must be pretinned for good connection and maximum transfer of heat.

b. To prevent overheating damage to electrical parts when soldering and unsoldering connections, hold bare wire, lead, or terminal lug close to soldering point with long roundnose pliers. Pliers act as heatsink and absorb excess heat.

**WARNING**

Cleaning compound, trichlorotrifluoroethane, for electrical parts is toxic and flammable, and reacts violently with aluminum, titanium, barium, lithium, samarium, sodium, and potassium. Always wear protective goggles and rubber gloves, and use only in a well-ventilated area. DO NOT wear Jewelry while using cleaning compound. Avoid contact with skin, eyes, and clothes, and DO NOT breathe vapors. Cleaning compound fumes or vapors can take the place of air and may become a cancer producing agent. DO NOT use near open flame or excessive heat. The compound's boiling point is 114°F (46°C). If you become dizzy while using cleaning compound, immediately get fresh air and medical help. If compound contacts eyes, immediately wash your eyes with water and get medical aid.

c. Clean all solder joints with a scrub brush (Item 3, Appendix B) and electrical parts trichlorotrifluoroethane (Item 40, Appendix B) after soldering to get a bright clean surface.

---

**1-20. HEAT SHRINK TUBING.**

---

Use heat shrink tubing (Item 41, Appendix B) to insulate soldered and crimped electrical connections as follows:

- (1) Cut desired length of new tubing twice the diameter of connection to be covered.
- (2) Slide tubing onto wire and out of the way before making connection.

---

**1-20. HEAT SHRINK TUBING (Con't).**

---

- (3) After making electrical connection, slide tubing into place over it.

**WARNING**

**Do not touch heat shrink tubing for at least 30 seconds after heating. Tubing is hot and can burn you.**

- (4) Hold heat gun 4-5 in. (10.2-12.7 cm) away from tubing and apply heat for about 30 seconds. Stop applying heat as soon as tubing forms to shape of connection.

---

**1-21. WIRE TERMINAL LUG AND CONNECTOR REPLACEMENT.**

---

**WARNING**

**Although battery disconnect switch must be on and battery ground cable connected to test electrical circuit voltage, turn off battery disconnect switch or disconnect battery ground cable before doing resistance tests or replacing parts. This will prevent electrical shock and damage to parts and equipment.**

- a. Cut off damaged terminal lug or connector with diagonal-cutting pliers.
- b. Slide new length of heat shrink tubing (Item 41, Appendix B) over wire if necessary.
- c. Using wire stripper, strip enough insulation from wire to allow bare wire to go all the way into hole in terminal lug or connector.
- d. Select proper terminal lug or connector for wire size and terminal stud or other mating connector.
- e. Insert bare end of wire all the way into terminal lug or connector.
- f. Crimp or solder terminal lug or connector to wire. Ensure that connection is tight.
- g. If heat shrink tubing (Item 41, Appendix B) is used, slide tubing over connection and shrink in place (see paragraph 1-20).

---

**1-22. WIRE REPLACEMENT.**

---

**WARNING**

**Although battery disconnect switch must be on and battery ground cable connected to test electrical circuit voltage, turn off battery disconnect switch or disconnect battery ground cable before doing resistance tests or replacing parts. This will prevent electrical shock and damage to parts and equipment.**

- a. If terminal lugs or connectors of wire to be replaced are covered with heat shrink tubing, cut off tubing using knife.
- b. If solder type terminal lug is in good condition, it can be unsoldered and reused.
- c. Unsolder wires from soldered splices and terminal connections.

---

**1-22. WIRE REPLACEMENT (Con't).**

---

- d. Cut new wire of same gage and type as wire being replaced to desired length using diagonal-cutting pliers.

**NOTE**

**Always use heat shrink tubing around wire splices or wrap them with electrical tape.**

- e. Slide new length of heat shrink tubing (Item 41, Appendix B) onto ends of new wire. If desired. If tubing is not available, use electrical tape (Item 36, Appendix B).

- f. Connect terminal lugs or connectors to wire by soldering or crimping as required. Ensure that connections are tight.

- g. To splice wires together, twist and tie end strands of each wire separately. After tinned ends have cooled, twist both ends together and reheat with soldering gun to fuse ends together.

- h. If heat shrink tubing (Item 41, Appendix B) is used, slide tubing over connections and shrink in place (see paragraph 1-20).

---

**1-23. WIRING HARNESS CONNECTOR REPAIR AND REPLACEMENT.**

---

All wiring harness connectors are of similar design and are repaired and replaced the same way. To repair or replace individual wires and pins, mating connectors must be disconnected, but it may not be necessary to remove connectors from their mounting points. Repair or replace wiring harness connectors as follows:

**WARNING**

**Although battery disconnect switch must be on and battery ground cable connected to test electrical circuit voltage, turn off battery disconnect switch or disconnect battery ground cable before doing resistance tests or replacing parts. This will prevent electrical shock and damage to parts and equipment.**

- (1) Unscrew retaining nut from connector and push back out of the way on wiring harness.
- (2) Pull retainer out of connector and slide back on wires to expose back of pins.
- (3) If replacing more than one wire or pin, tag each wire before removal with letter shown on face of connector.
- (4) If replacing entire connector:
  - (a) Using soldering gun, unsolder each wire from pin.
  - (b) Discard defective connector.
- (5) If replacing individual wire or pin:
  - (a) Using long roundnose pliers, pull pin out of connector.
  - (b) Using soldering gun and long roundnose pliers, unsolder wire from pin.
- (6) Pull wire(s) out of holes in retainer and retaining nut.
- (7) Replace defective parts as required.

---

**1-23. WIRING HARNESS CONNECTOR REPAIR AND REPLACEMENT (Con't).**

---

- (8) Insert wire(s) through holes in retaining nut and retainer.
- (9) Using soldering gun and long roundnose pliers, solder wire(s) onto pins. Ensure that each connection is solid.
- (10) Using long roundnose pliers, push pin(s) into proper hole(s) of connector.
- (11) Remove tags from wires.
- (12) Push retainer into connector. Install retaining nut onto connector and tighten.

---

**1-24. ELECTRICAL GROUND POINTS.**

---

Many electrical problems are the result of poor ground connections. You can ensure that ground connections are good by performing the following steps:

**WARNING**

**Although battery disconnect switch must be on and battery ground cable connected to test electrical circuit voltage, turn off battery disconnect switch or disconnect battery ground cable before doing resistance tests or replacing parts. This will prevent electrical shock and damage to parts and equipment.**

- (1) Remove hardware connecting ground cable terminal lug to ground point.

**WARNING**

**Cleaning compound, trichlorotrifluoroethane, for electrical parts is toxic and flammable, and reacts violently with aluminum, titanium, barium, lithium, samarium, sodium, and potassium. Always wear protective goggles and rubber gloves, and use only in a well-ventilated area. DO NOT wear Jewelry while using cleaning compound. Avoid contact with skin, eyes, and clothes, and DO NOT breathe vapors. Cleaning compound fumes or vapors can take the place of air and may become a cancer producing agent. DO NOT use near open flame or excessive heat. The compound's boiling point is 114°F (46°C). If you become dizzy while using cleaning compound, immediately get fresh air and medical help. If compound contacts eyes, immediately wash your eyes with water and get medical aid.**

- (2) Clean mounting hardware, ground cable terminal lugs, and ground point with trichlorotrifluoroethane (Item 40, Appendix B) and a scrub brush (Item 3, Appendix B).
- (3) Remove any rust with a wire brush (Item 4, Appendix B) and crocus cloth (Item 7, Appendix B).
- (4) Look for cracks, loose terminal lugs, and stripped threads. Replace any defective parts.
- (5) Install hardware connecting ground cable terminal lug to ground point. Ensure that all hardware is tight.