

1A2

4425 COMBINE

PRIMARY PICTORIAL INDEX

Z117454 -UN-01JAN94

- 20 = 1B3
- 30 = 1D11
- 40 = 1F3
- 60 = 2B2
- 70 = 2D3
- 90 = 3B3
- 120 = 4B3

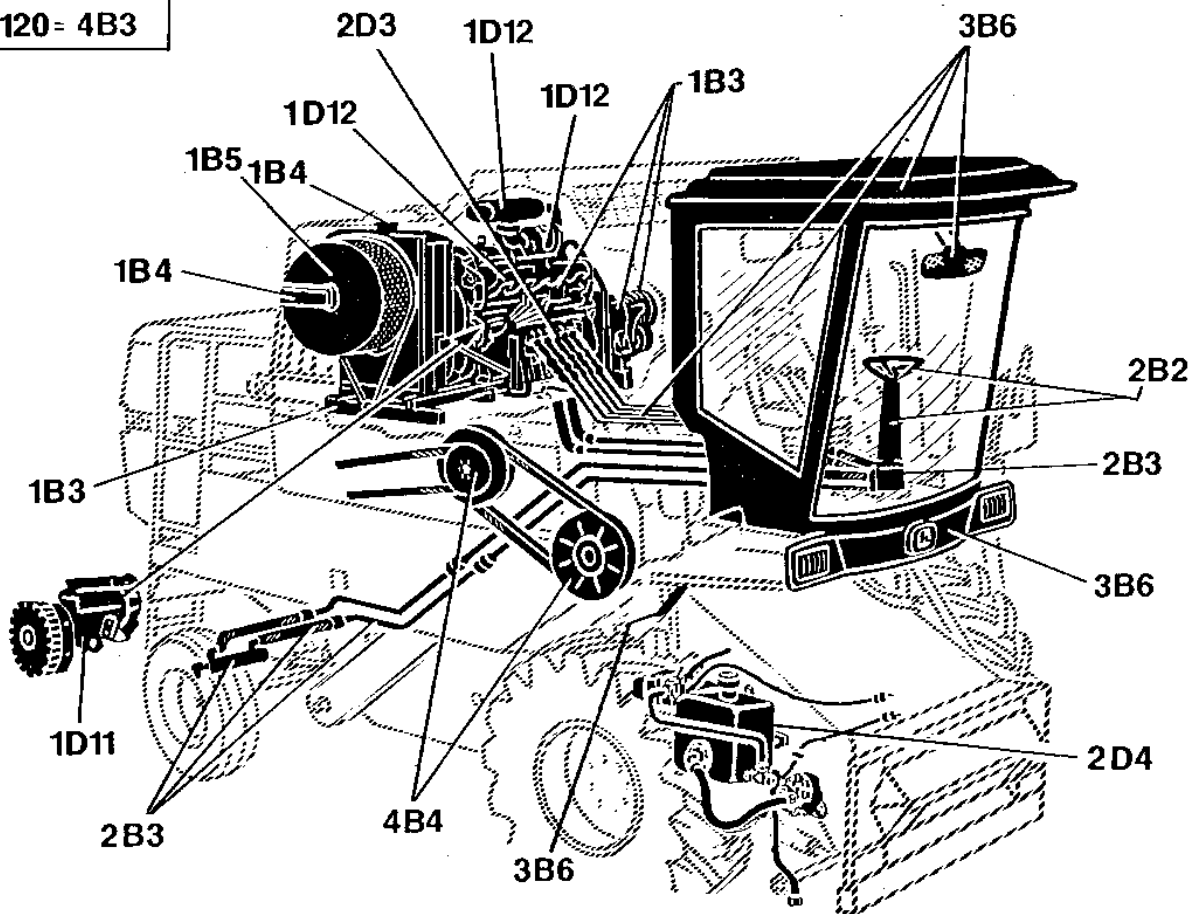
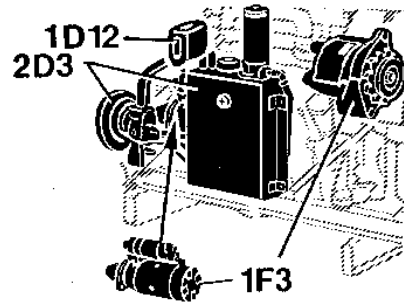

Z117454

1A3

4425 COMBINE

PRIMARY PICTORIAL INDEX

Z117453 -UN-01JAN94

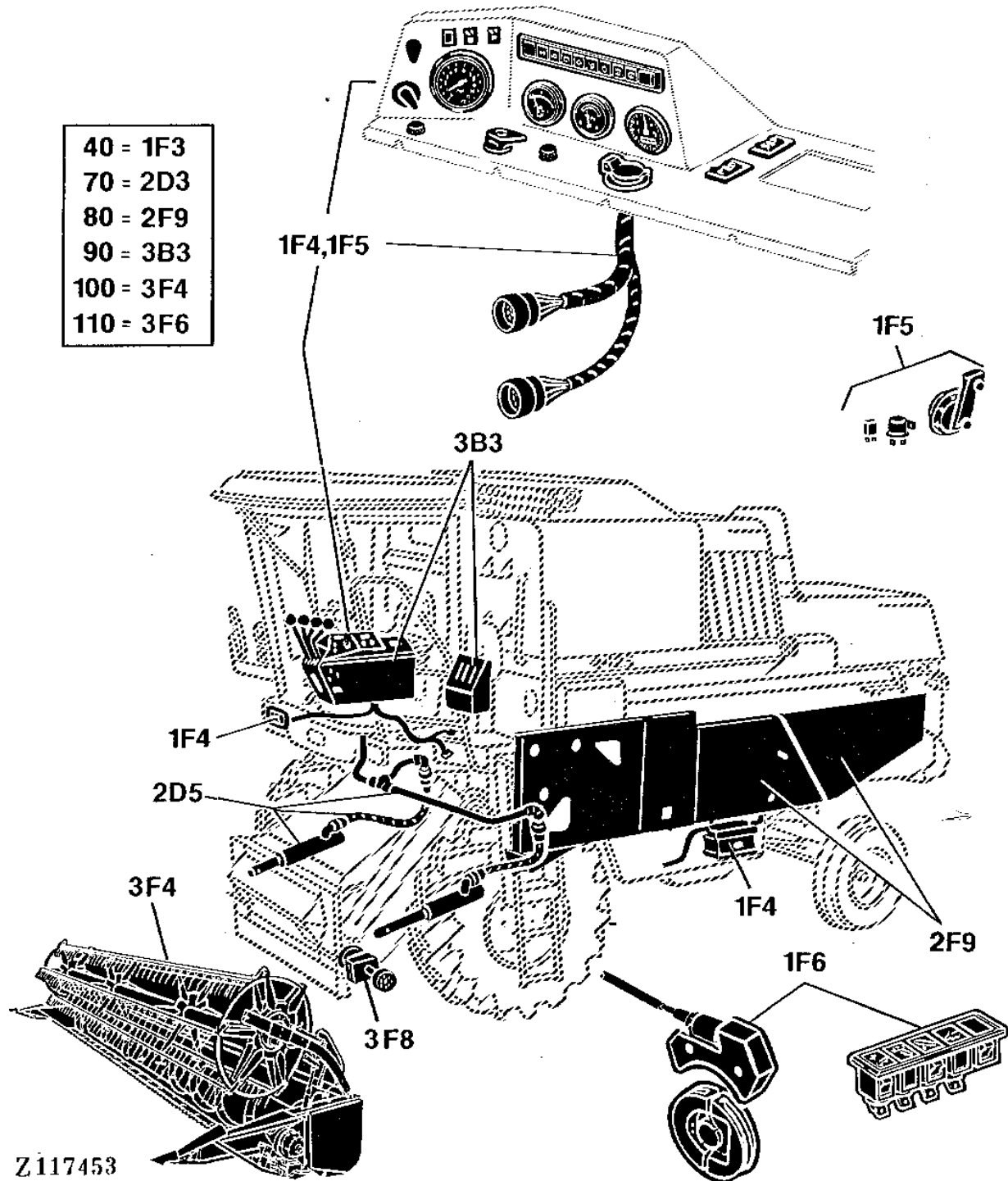

1A4

4425 COMBINE

PRIMARY PICTORIAL INDEX

Z117452 -UN-01JAN94

20	= 1B3
40	= 1F3
50	= 1J2
60	= 2B2
90	= 3B3
110	= 3F6
120	= 4B3
140	= 4I2

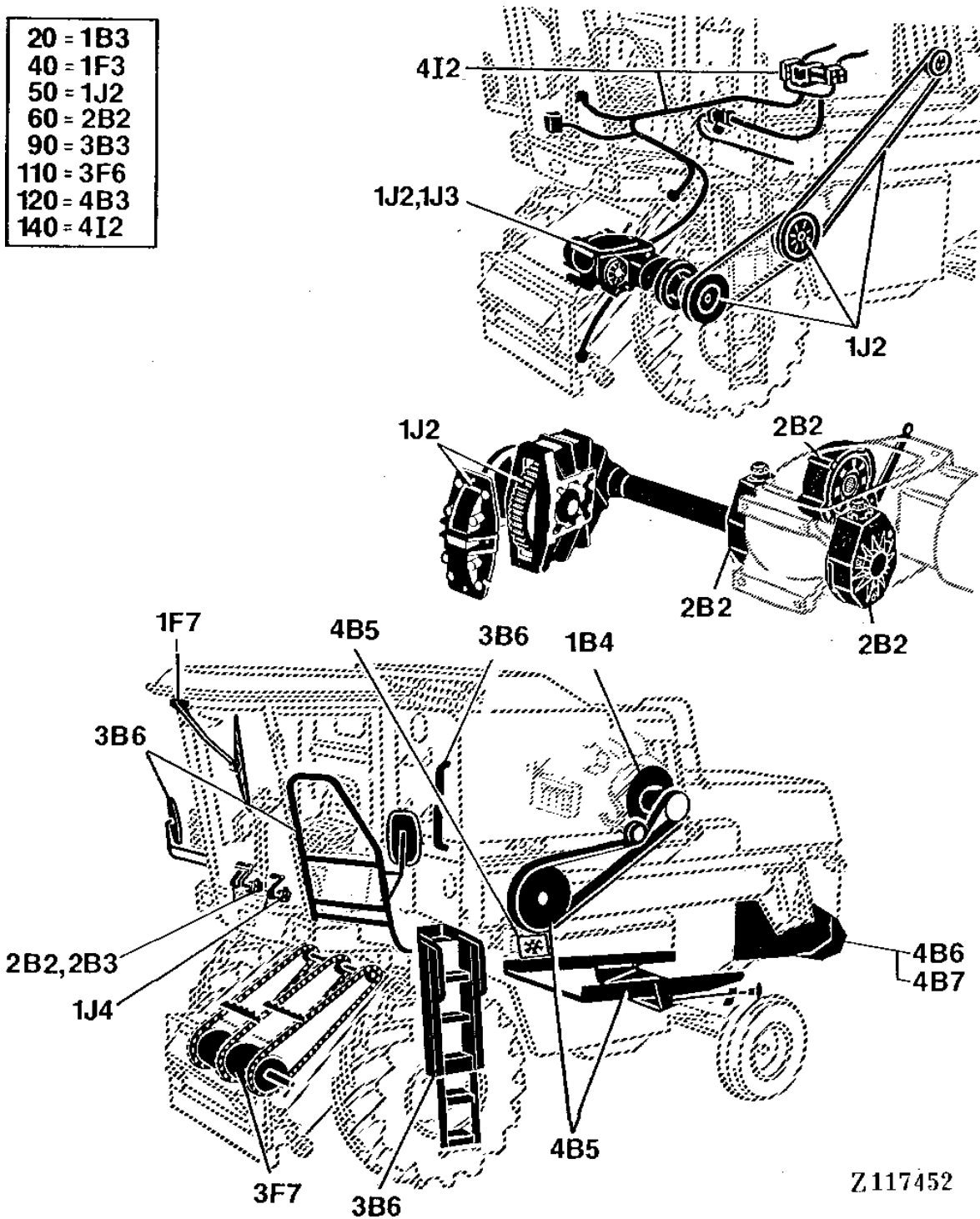

Z117452

1A5

4425 COMBINE

PRIMARY PICTORIAL INDEX

Z117451 -UN-01JAN94

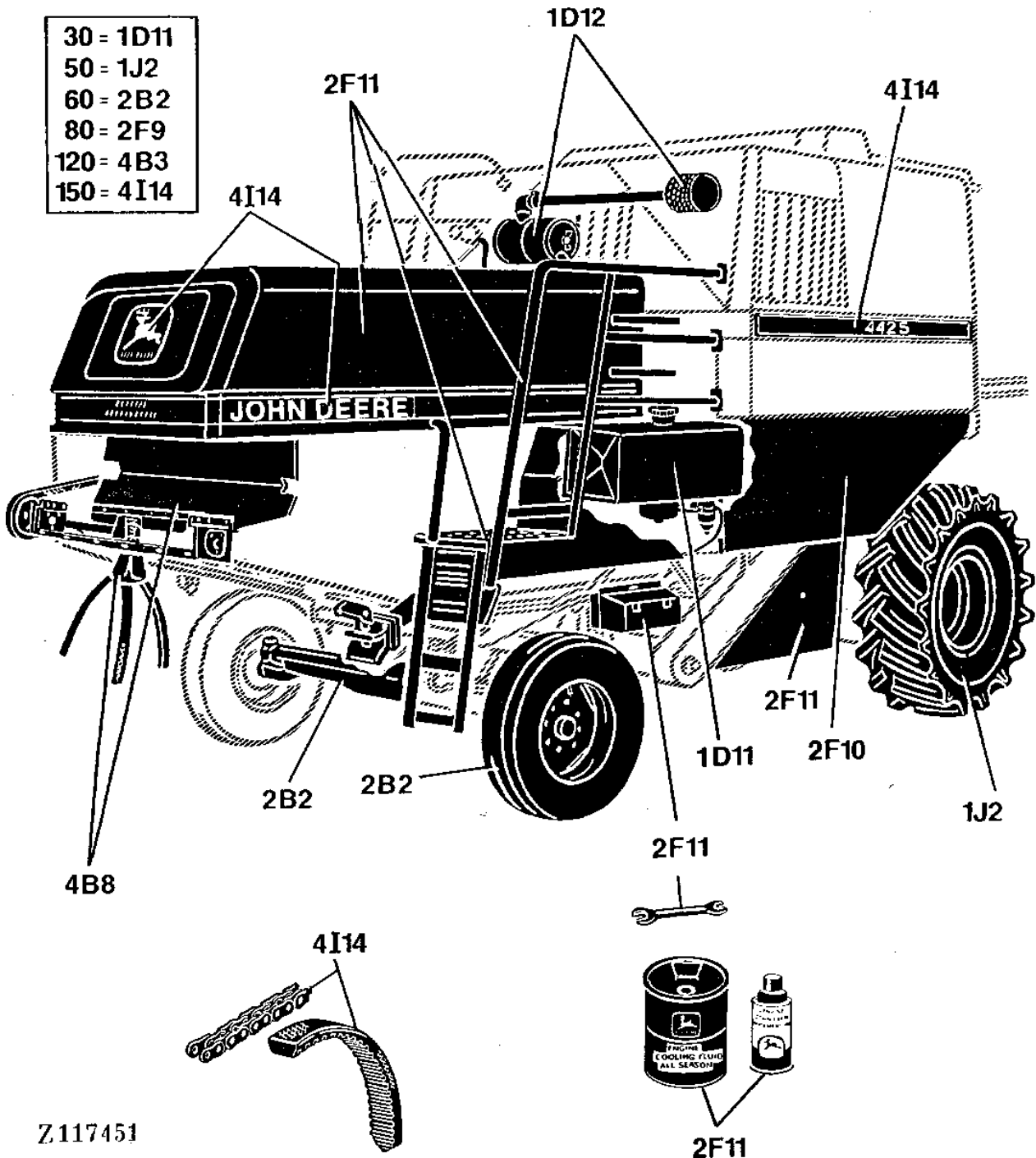

Z117451

1A6

4425 COMBINE

PRIMARY PICTORIAL INDEX

Z117450 -UN-01JAN94

50	=	1J2
80	=	2F9
90	=	3B3
120	=	4B3

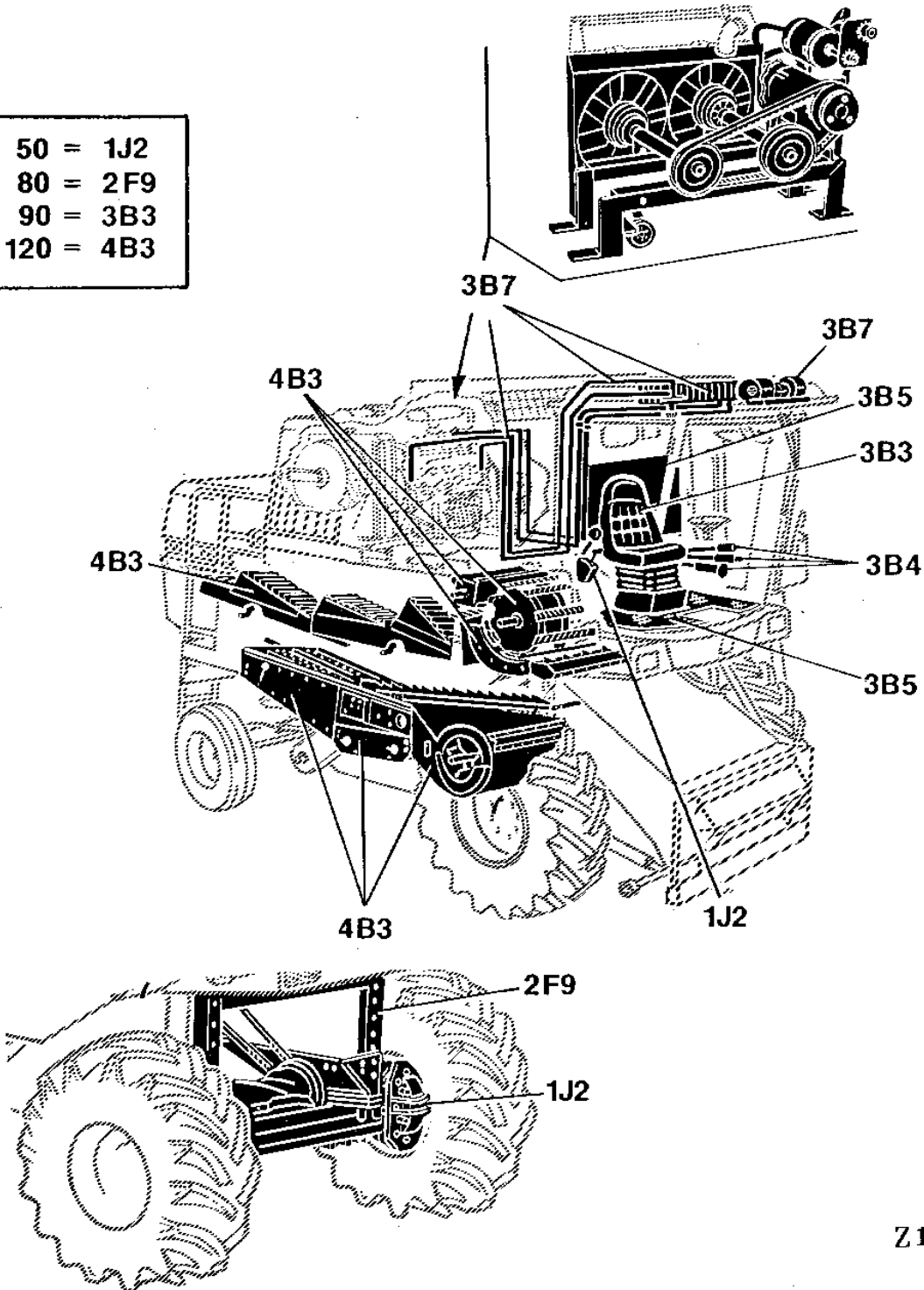

Z117450

1A7

4425 COMBINE

PRIMARY PICTORIAL INDEX

Z117449 -UN-01JAN94

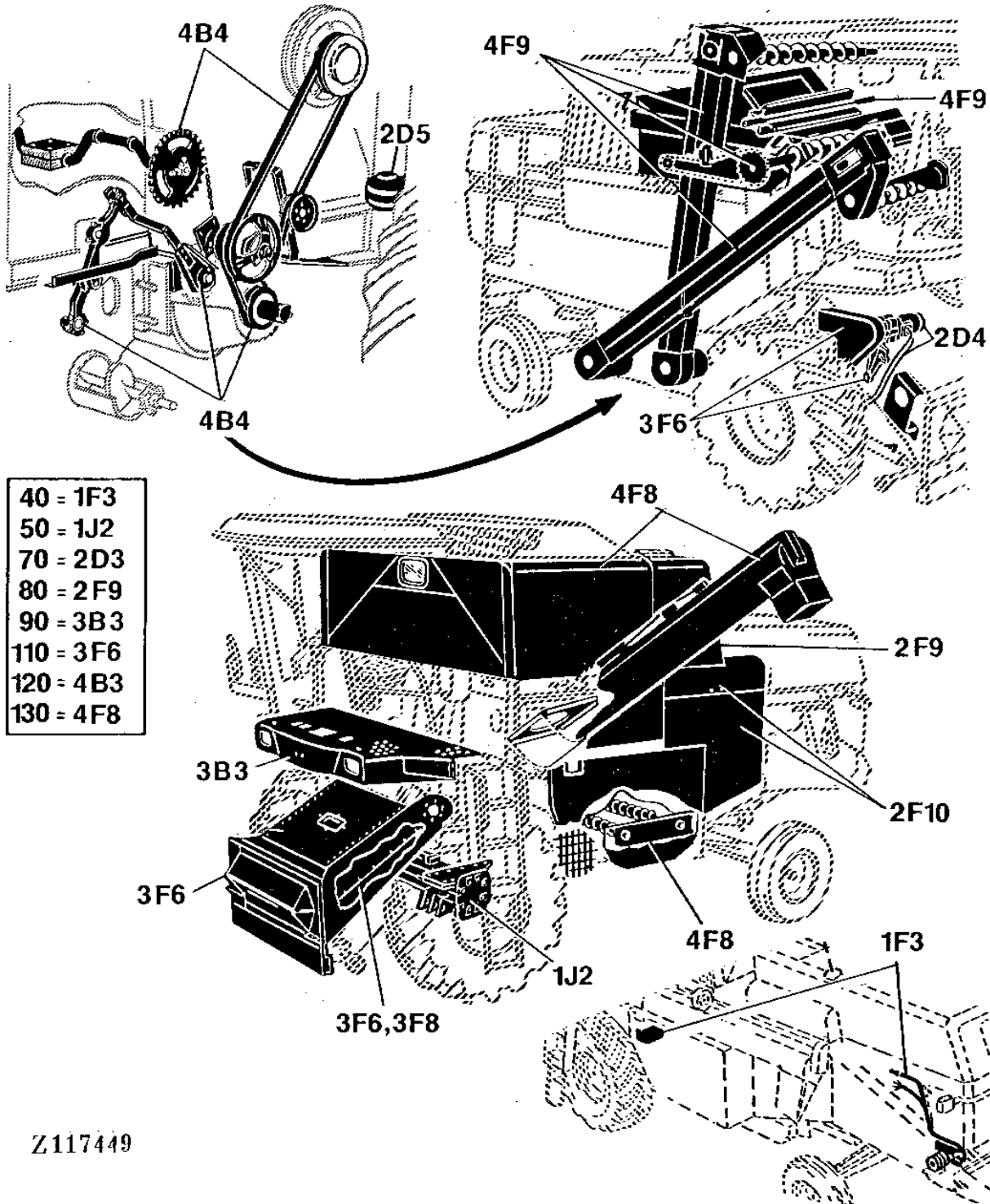

Z117449

1A8

4425 COMBINE

Z109222 -UN-01JAN94



JOHN DEERE 4425 COMBINE WITH 454A ROW-CROP HEAD

(SPECIFICATIONS AND DESIGN SUBJECT TO CHANGE WITHOUT NOTICE)

1A9

4425 COMBINE

NOTE

FOR 200 SERIES PLATFORM PARTS INFORMATION, REFER TO JOHN DEERE 200 SERIES PLATFORM PARTS CATALOG - PC-1558.

FOR 40 SERIES CORN HEAD PARTS INFORMATION, REFER TO JOHN DEERE 40 SERIES CORN HEAD PARTS CATALOG - PC-1223.

FOR 50A SERIES ROW-CROP HEAD PARTS INFORMATION, REFER TO JOHN DEERE 50A SERIES ROW-CROP HEAD PARTS CATALOG - PC-1747.

FOR 212 THREE-ROLLER BELT PICKUP PARTS INFORMATION, REFER TO JOHN DEERE THREE-ROLLER BELT PICKUP PARTS CATALOG - PC-1189 (200 SERIES) OR PC-2210 (900 SERIES).

IMPORTANT

THIS PARTS CATALOG CONTAINS PARTS INFORMATION FOR THE 4425 COMBINE. MACHINE VINTAGE IS DETERMINED BY THE COMBINE SERIAL NUMBER OR THE PRODUCT IDENTIFICATION NUMBER (PIN). IT IS IMPORTANT THAT THE CORRECT NUMBERS BE USED WHEN ORDERING PARTS.

1A10

4425 COMBINE

SERIAL NUMBER AND PRODUCT IDENTIFICATION NUMBER (PIN) PLATES

USE ALL NUMBERS, LETTERS AND SPACES SHOWN ON THE SERIAL NUMBER PLATE OR THE PRODUCT IDENTIFICATION NUMBER PLATE IN WARRANTY CORRESPONDENCE.

PRODUCT IDENTIFICATION NUMBER PLATE

THE PRODUCT IDENTIFICATION NUMBER PLATE (PIN) IS LOCATED ON THE RIGHT-HAND SIDE OF THE OPERATOR'S PLATFORM. AN EXAMPLE OF THIS PIN PLATE IS:

Z04425X044250

Z0 - MANUFACTURING UNIT (ZWEIBRUECKEN WORKS)
4425 - MODEL IDENTIFIER
X - CONFIGURATION CODE/MODEL IDENTIFIER SUFFIX
044250 - SEQUENTIAL NUMBER USED IN SERIAL NO. COLUMN

1A11

4425 COMBINE

ENGINE SERIAL NUMBER

THE ENGINE SERIAL NUMBER PLATE IS LOCATED ON THE RIGHT-HAND SIDE OF THE ENGINE BLOCK, NEAR THE MECHANICAL FUEL TRANSFER PUMP.

AN EXAMPLE OF THE ONE-LINE, SIXTEEN-DIGIT NUMBER ON THIS SERIAL NUMBER PLATE IS:

6359DZ04227799CD

6 - NUMBER OF CYLINDERS
359 - CUBIC INCH DISPLACEMENT
D - FUEL TYPE OF ENGINE (DIESEL)
Z - MANUFACTURING UNIT OF MACHINE (ZWEIBRUECKEN WORKS)
04 - ENGINE VERSION
227799 - ENGINE SERIAL NUMBER
CD - MANUFACTURING UNIT OF ENGINE (SARAN WORKS)

AN EXAMPLE OF THE TWO-LINE NUMBER ON THIS SERIAL NUMBER PLATE IS:

CD6359D227799
6359DZ04

(FIRST LINE)

CD - MANUFACTURING UNIT (SARAN WORKS)
6 - NUMBER OF CYLINDERS
359 - CUBIC INCH DISPLACEMENT
D - CONFIGURATION CODE/MODEL IDENTIFIER SUFFIX
227799 - SEQUENTIAL NUMBER USED IN SERIAL NO. COLUMN

(SECOND LINE)

6 - NUMBER OF CYLINDERS
359 - CUBIC INCH DISPLACEMENT
D - FUEL TYPE OF ENGINE (DIESEL)
Z - MANUFACTURING UNIT OF MACHINE (ZWEIBRUECKEN WORKS)
04 - ENGINE VERSION

PARTS LISTING INFORMATION

SERIAL NUMBER OR PRODUCT IDENTIFICATION NUMBER (PIN) INFORMATION SHOWS ON WHICH MACHINES A PART MAY BE USED. FOR EXAMPLE:

- THE PART CAN BE USED ON ALL MACHINES.
- 000000 THE PART CAN BE USED ON ALL MACHINES UP TO AND INCLUDING THE SERIAL NUMBER LISTED.
- 000000- THE PART CAN BE USED ON ALL MACHINES BEGINNING WITH THE SERIAL NUMBER LISTED.
- 000000-000000 THE PART CAN BE USED ON ALL MACHINES BETWEEN AND INCLUDING THE SERIAL NUMBERS LISTED.

WHEN XXXXXX'S ARE LISTED IN PLACE OF A SERIAL NUMBER, A SERIAL NUMBER CHANGE WAS MADE, BUT THE EXACT SERIAL NUMBER WAS NOT AVAILABLE WHEN THE CATALOG WAS PRINTED.

1A12

4425 COMBINE

DIRECTION ARROW

ARROWS ARE USED WITH ILLUSTRATIONS TO INDICATE THE FRONT OF THE UNIT. "RIGHT-HAND" AND "LEFT-HAND" SIDES ARE DETERMINED BY FACING IN THE DIRECTION OF MACHINE FORWARD TRAVEL.

BOX-ENCLOSED ILLUSTRATIONS

A KEY NUMBER, SHOWN IN THE PARTS LIST, IS ASSIGNED TO A BOX ENCLOSING ALL PARTS SOLD AS A SERVICE ASSEMBLY. A BOX NOT KEYED INCLUDES NON-CURRENT PARTS.

KITS

KIT INFORMATION WILL BE FOUND IMMEDIATELY FOLLOWING THE STORY IN WHICH IT IS USED. THE ILLUSTRATION IS REPEATED WITH ONLY THE KIT PARTS CALLED OUT AND WITH ALL OTHER PARTS SHOWN IN PHANTOM FOR RELATIONSHIP.

JDM REMANUFACTURED COMPONENTS

THE SERVICE PARTS LISTED IN THIS CATALOG ARE INTENDED FOR THE REPAIR OF ORIGINAL EQUIPMENT COMPONENTS. ALTHOUGH MOST SERVICE PARTS MAY BE USED TO REPAIR REMANUFACTURED COMPONENTS, THE REMANUFACTURED DESIGN MAY CHANGE PARTS SUFFICIENTLY SO THAT SERVICE PARTS ARE INADEQUATE OR NOT USABLE.

BOLT AND CAP SCREW STRENGTH IDENTIFICATION

BOLTS AND CAP SCREWS REQUIRED TO HAVE HIGH-STRENGTH QUALITIES EQUIVALENT TO SAE GRADE 8 ARE IDENTIFIED THROUGHOUT THIS CATALOG BY THE DESCRIPTION HS SAE 8. ALL STANDARD BOLTS AND CAP SCREWS ARE SAE GRADE 5 OR LOWER.

COMPLETE GOODS LISTINGS

COMPLETE GOODS ARE LISTED IN BOLD FACE TYPE. ORDER SEPARATELY. DO NOT INCLUDE ON REPLACEMENT PARTS ORDER.

SI UNITS OF MEASURE

METRIC DIMENSIONS ARE GIVEN, WHERE APPLICABLE, THROUGHOUT THIS PARTS CATALOG.

TRADEMARKS

THROUGHOUT THIS PARTS CATALOG, YOU WILL FIND THE FOLLOWING DEERE & COMPANY TRADEMARKS:

DIAL-A-MATIC™
HARVESTRAK™
POSI-TORQ™

TORQ-GARD SUPREME®
QUIK-TATCH™

CHANGE INDICATOR LINE (MICROFICHE CATALOGS ONLY)

CHANGES AFFECTING THE ORDERING OF PARTS ARE IDENTIFIED BY VERTICAL LINES MARKED IN THE LEFT-HAND MARGIN OF REVISED PARTS LISTING IMAGES. A LINE IS ALSO AT THE LEFT-HAND EDGE OF THE SAME PART NUMBER IN THE NUMERICAL INDEX TO SHOW THE LOCATION OF REVISED INFORMATION.

1A13

4425 COMBINE

SECTIONAL INDEX

	SECTION
PRIMARY PICTORIAL INDEX AND GENERAL INFORMATION	10
BASIC ENGINE	20
FUEL AND AIR	30
ELECTRICAL	40
POWER TRAIN	50
STEERING AND BRAKES	60
HYDRAULICS	70
SEPARATOR SHELL	80
OPERATOR'S STATION	90
HEADERS - REFER TO INDIVIDUAL HEADER PARTS CATALOGS	100
FEEDER HOUSE	110
SEPARATOR	120
GRAIN TANK AND UNLOADING AUGER	130
HEADER HEIGHT CONTROL	140
DECALS, BELTS AND CHAINS	150
NUMERICAL INDEX	180

1A14

4425 COMBINE

ALPHABETICAL INDEX

GRID		PAGE	GRID		PAGE
A					
2E14	ACCUMULATOR.....	70-37	3D22	CAB ROOF AIR FILTER	90-68
3G17	ADAPTER PLATES, PLATFORM	110-36	3D9	CAB ROOF SEAL.....	90-54
3C11	ADJUSTMENT INDICATOR, CONCAVE.....	90-30	1I12	CAB ROOF WIRING.....	40-80
1E3	AIR CLEANER AND AIR INTAKE TUBES	30-16	3D7	CAB SOUNDPROOFING	90-52
3F1	AIR CONDITIONING CLEANING UNIT TUBE	90-98	3D10	CAB SOUNDPROOFING (RIGHT-HAND)	90-55
3E15	AIR CONDITIONING HOSES AND COUPLERS	90-86	3C23	CAB WINDOWS AND MOLDINGS	90-44
3E22	AIR CONDITIONING SUCTION FAN DRIVE	90-94	1I16	CABLE CLIPS,CONNECTORS AND PLUGS	40-84
3D20	AIR FILTER, CAB ROOF	90-66	1B17	CAMSHAFT.....	20-13
3D22	AIR FILTER, CAB ROOF	90-68	1G1	CENTRAL ELECTRICAL HOUSING	40-20
1D13	AIR INTAKE MANIFOLD	30-2	4C18	CHAFFER	120-38
1E3	AIR INTAKE TUBES, AIR CLEANER	30-16	4E1	CHAFFER DRIVE	120-72
3D19	AIR OUTLET PANEL	90-64	4C16	CHAFFER FRAME	120-36
1F13	ALTERNATOR	40-7	3F23	CHAIN, FEEDER CONVEYOR	110-18
1F14	ALTERNATOR - ROBERT BOSCH (65 AMP)	40-8	4F24	CHAIN, TAILINGS ELEVATOR	130-16
1F12	ALTERNATOR ATTACHING PARTS.....	40-6	4J4	CHAINS, LEFT-HAND SIDE.....	150-15
1I7	ANTENNA	40-75	4I23	CHAINS, RIGHT-HAND SIDE	150-10
1F12	ATTACHING PARTS, ALTERNATOR	40-6	4J1	CHAINS, RIGHT-HAND SIDE	150-12
3C21	ATTACHING PARTS, CAB	90-42	4J3	CHAINS, RIGHT-HAND SIDE	150-14
4H1	AUGER, LEVELING, GRAIN TANK.....	130-44	4F10	CLEAN GRAIN AUGERS, HOUSING	130-2
1C6	AUXILIARY PULLEY.....	20-27	4F12	CLEAN GRAIN AUGERS, LOWER TAILINGS	130-4
2C11	AXLE SUPPORT AND V-SUPPORT FOR REAR AXLE	60-34	4F18	CLEAN GRAIN ELEVATOR DRIVE.....	130-10
2C15	AXLE, REAR.....	60-38	4F16	CLEAN GRAIN ELEVATOR, CONVEYOR CHAIN	130-8
			4F20	CLEAN GRAIN, ELEVATOR, UPPER.....	130-12
B					
1G13	BASIC WIRING HARNESS	40-32	2G15	CLEANING FAN AND FEEDER HOUSE GUARDS	80-30
1G15	BASIC WIRING HARNESS	40-34	2G21	CLEANING FAN GUARD, RIGHT-HAND	80-36
1G17	BASIC WIRING HARNESS	40-36	2G19	CLEANING FAN GUARDS, LEFT-HAND	80-34
1G19	BASIC WIRING HARNESS	40-38	4D12	CLEANING FAN TENSION PULLEY	120-57
1G21	BASIC WIRING HARNESS	40-40	4D13	CLEANING FAN-ADJUSTING ROD	120-58
1G23	BASIC WIRING HARNESS	40-42	4C22	CLEANING SHOE SUSPENSION	120-42
1F8	BATTERY AND CABLES	40-2	3F1	CLEANING UNIT TUBE, AIR CONDITIONING.....	90-98
2G9	BATTERY MOUNTINGS	80-24	1B21	CLOSING (WITHOUT OIL FILLER NECK)	20-17
2G11	BATTERY MOUNTINGS	80-26	1J24	CLUTCH	50-22
1C1	BEARING KIT, UNDERSIZE CRANKSHAFT	20-22	3E8	CLUTCH AND SERVICE VALVES, COMPRESSOR	90-79
1B25	BEARINGS,CRANKSHAFT.....	20-21	1J14	CLUTCH CYLINDER	50-11
4C2	BEATER	120-22	1J21	CLUTCH HOUSING, DRIVE SHEAVE	50-18
4C10	BEATER DRIVE	120-30	1J23	CLUTCH LINKAGE.....	50-21
4C4	BEATER, VARIABLE DRIVE WITH CENTER OIL SUPPLY.....	120-24	1J15	CLUTCH MASTER CYLINDER	50-12
2E17	BEATER, VARIABLE DRIVE WITH CENTER OIL SUPPLY, HYDRAULIC LINE	70-40	1J17	CLUTCH OIL LINES.....	50-14
1C11	BELTS AND FAN, WATER PUMP	20-32	1J13	CLUTCH PEDAL.....	50-10
4D5	BLADES, FAN SHAFT	120-50	1E1	COLD WEATHER STARTING AID	30-14
4E7	BLADES, STRAW CHOPPER	120-78	2H17	COMBINE MAINTENANCE PRODUCTS.....	80-56
1B8	BLOCK,CYLINDER	20-4	1F24	COMPRESSOR CABLES.....	40-18
1B9	BLOCK,CYLINDER	20-5	3E8	COMPRESSOR CLUTCH AND SERVICE VALVES.....	90-79
3F12	BOTTOM SHEET, FEEDER HOUSE.....	110-6	3E7	COMPRESSOR HARDWARE KIT	90-78
2B14	BRAKE CYLINDER.....	60-12	3E11	COMPRESSOR HOSES	90-82
2B8	BRAKE LINES (LOWER)	60-6	3E5	COMPRESSOR MOUNTING	90-76
2B10	BRAKE LINES (UPPER)	60-8	3E9	COMPRESSOR PARTS	90-80
2B4	BRAKE PEDALS.....	60-2	4B16	CONCAVE.....	120-10
2B6	BRAKE VALVE.....	60-4	4B18	CONCAVE - SUSPENSION	120-12
C					
3C21	CAB ATTACHING PARTS	90-42	3C11	CONCAVE ADJUSTMENT INDICATOR	90-30
3D24	CAB FAN	90-70	3C9	CONCAVE AND BRAKE LEVERS	90-28
3E1	CAB FAN	90-72	3E20	CONDENSER AND MOUNTING	90-92
3D1	CAB MOUNTING AND CYLINDERS.....	90-46	3E17	CONDENSER FAN, FRONT	90-88
3D3	CAB MOUNTING AND CYLINDERS.....	90-48	3E18	CONDENSER FAN, REAR	90-90
3D13	CAB ROOF	90-58	1C3	CONNECTING ROD.....	20-24
3D20	CAB ROOF AIR FILTER	90-66	3C7	CONTROL LEVER - CUTTING PLATFORM/ HYDRAULIC REVERSER	90-26
			3C18	CONTROL LEVER, CYLINDER SPEED	90-39
			2D20	CONTROL VALVE FITTINGS, MAIN.....	70-16
			2D18	CONTROL VALVE KIT, MAIN	70-14
			2D16	CONTROL VALVE POPPETS, MAIN	70-12
			4I9	CONTROL VALVE, DIAL-A-MATIC	140-8
			2D14	CONTROL VALVE, MAIN.....	70-10
			4F16	CONVEYOR CHAIN, CLEAN GRAIN ELEVATOR	130-8
			1D2	COUNTERSHAFT FOR ROTARY RADIATOR SCREEN ...	20-50
			4E20	COUNTERSHAFT, STRAW CHOPPER	120-92
			2F7	COUPLER, CUTTING PLATFORM	70-56

1A15

4425 COMBINE

ALPHABETICAL INDEX - CONTINUED

GRID		PAGE	GRID		PAGE
3C20	COVER PLATE, OPERATOR'S PLATFORM	90-41	1J21	DRIVE SHEAVE, CLUTCH HOUSING	50-18
1B13	COVER,ROCKER ARM	20-9	4E23	DRIVE SHIELD, STRAW CHOPPER.....	120-95
1B23	COVER,TIMING GEAR.....	20-19	1K13	DRIVE WHEEL AXLE AND EXTENSION	50-36
1B24	COVER,TIMING GEAR.....	20-20	1K15	DRIVE WHEELS.....	50-38
3D15	COVERS, CAB	90-60	4C10	DRIVE, BEATER.....	120-30
4G20	COVERS, INNER UNLOADING AUGER.....	130-38	2D10	DRIVE, MAIN HYDRAULIC PUMP	70-6
1B25	CRANKSHAFT BEARINGS	20-21	4E3	DRIVE, SLIP CLUTCH STRAW WALKER	120-74
1C5	CRANKSHAFT PULLEY.....	20-26	3E24	DRIVE, SUCTION FAN	90-96
4D20	CURTAIN	120-66	4G7	DRIVE, TAILINGS ELEVATOR	130-24
2E19	CUTTING PLATFORM PRESSURE INDICATOR HOSE	70-42	4G9	DRIVE, TAILINGS ELEVATOR	130-26
2F7	CUTTING PLATFORM, COUPLER	70-56	4H15	DRIVE, UNIVERSAL, OUTER UNLOADING AUGER.....	130-60
4B9	CYLINDER ACCESS DOOR	120-2	4H17	DRIVE, UNIVERSAL, OUTER UNLOADING AUGER.....	130-62
1B8	CYLINDER BLOCK.....	20-4	4H3	DRIVE, UNLOADING, GRAIN TANK.....	130-47
1B9	CYLINDER BLOCK.....	20-5	4H4	DRIVE, UNLOADING, GRAIN TANK.....	130-48
1B14	CYLINDER HEAD.....	20-10	4H8	DRIVES, PADDLE, INNER UNLOADING AUGER	130-52
3C18	CYLINDER SPEED CONTROL LEVER.....	90-39	4I12	DROP RATE VALVE KIT, DIAL-A-MATIC.....	140-11
4C12	CYLINDER SPEED SENDING UNIT.....	120-32	4I11	DROP RATE VALVE, DIAL-A-MATIC	140-10
2C9	CYLINDER STEERING.....	60-32			
2B14	CYLINDER, BRAKE	60-12		E	
2C7	CYLINDER, STEERING	60-30	1F18	ELECTRICAL CONNECTIONS ENGINE	40-12
3D1	CYLINDERS, CAB	90-46	1F21	ELECTRICAL FUEL INJECTION PUMP SHUT-OFF CABLE	40-15
3D3	CYLINDERS, CAB	90-48	1E9	ELECTRICAL FUEL TRANSFER PUMP	30-22
	D		4I3	ELECTRICAL PARTS, DIAL-A-MATIC	140-2
4J24	DECALS	150-35	4F18	ELEVATOR DRIVE, CLEAN GRAIN	130-10
4J23	DECALS, ENGINE SECTION	150-34	4F14	ELEVATOR HOUSING, CLEAN GRAIN, LOWER	130-6
4J13	DECALS, LEFT HAND	150-24	4F16	ELEVATOR, CLEAN GRAIN, CONVEYOR CHAIN	130-8
4J11	DECALS, LEFT-HAND	150-22	4F20	ELEVATOR, CLEAN GRAIN, UPPER	130-12
4J15	DECALS, LEFT-HAND	150-26	4F22	ELEVATOR, TAILINGS.....	130-14
4J19	DECALS, OPERATOR'S PLATFORM	150-30	4G7	ELEVATOR, TAILINGS, DRIVE	130-24
4J21	DECALS, OPERATOR'S PLATFORM	150-32	4G9	ELEVATOR, TAILINGS, DRIVE	130-26
4J17	DECALS, REAR	150-28	1C21	ENGINE - MOUNTING PARTS	20-43
4J5	DECALS, RIGHT HAND.....	150-16	1D4	ENGINE BREATHER AND DRAINING ENGINE OIL	20-52
4J7	DECALS, RIGHT-HAND	150-18	2G7	ENGINE COMPARTMENT FLOOR SHEETS	80-22
4J9	DECALS, RIGHT-HAND	150-20	2H13	ENGINE COMPARTMENT SHEETS	80-52
4E22	DEFLECTOR STORAGE RETAINERS, STRAW CHOPPER	120-94	2H11	ENGINE COMPARTMENT SHEETS MOUNTING	80-50
4E16	DEFLECTOR, STRAW CHOPPER	120-88	1C20	ENGINE COOLANT HEATER	20-42
4I9	DIAL-A-MATIC CONTROL VALVE.....	140-8	1C18	ENGINE GASKET SET	20-40
4I11	DIAL-A-MATIC DROP RATE VALVE.....	140-10	4J23	ENGINE SECTION DECALS	150-34
4I12	DIAL-A-MATIC DROP RATE VALVE KIT	140-11	1D6	ENGINE SUPPORT	20-54
4I3	DIAL-A-MATIC ELECTRICAL PARTS	140-2	1F16	ENGINE WIRING HARNESS.....	40-10
4I7	DIAL-A-MATIC HYDRAULIC LINES	140-6	1F18	ENGINE, ELECTRICAL CONNECTIONS	40-12
4I5	DIAL-A-MATIC MECHANICAL PARTS	140-4	1F20	ETHER COLD WEATHER STARTING AID CABLE	40-14
1K7	DIFFERENTIAL.....	50-30	3E2	EVAPORATOR / HEATER CORE	90-73
1B10	DIPSTICK	20-6	1E5	EXHAUST EJECTOR AND PIPE.....	30-18
2B12	DISK BRAKES FOOT BRAKES.....	60-10	1D14	EXHAUST MANIFOLD	30-3
2B15	DISK BRAKES HANDBRAKE	60-14	1K13	EXTENSION, DRIVE WHEEL AXLE	50-36
1F22	DISTRIBUTOR BOX	40-16	4D19	EXTENSION, STRAW WALKER	120-65
4E14	DISTRIBUTOR, STRAW CHOPPER	120-86			
1I10	DOME LIGHT	40-78		F	
1I11	DOME LIGHT	40-79	1C11	FAN AND BELTS, WATER PUMP	20-32
3D5	DOOR HANDLE, CAB	90-50	4D3	FAN HOUSING.....	120-48
4G17	DOOR, ACCESS, GRAIN TANK	130-34	4D5	FAN SHAFT AND BLADES	120-50
1D4	DRAINING ENGINE OIL, ENGINE BREATHER	20-52	3F23	FEEDER CONVEYOR CHAIN.....	110-18
4I17	DRIVE BELTS, LEFT-HAND SIDE	150-4	3G15	FEEDER CONVEYOR DRIVE	110-34
4I19	DRIVE BELTS, LEFT-HAND SIDE	150-6	3F21	FEEDER CONVEYOR DRUM	110-16
4I20	DRIVE BELTS, LEFT-HAND SIDE	150-7	3F9	FEEDER CONVEYOR HOUSING	110-2
4I21	DRIVE BELTS, LEFT-HAND SIDE	150-8	3F11	FEEDER CONVEYOR RETURN SHIELDS.....	110-4
4I22	DRIVE BELTS, LEFT-HAND SIDE	150-9	3F14	FEEDER HOUSE FRONT SHIELD	110-9
4I15	DRIVE BELTS, RIGHT-HAND SIDE	150-2	3F12	FEEDER HOUSE FRONT SHIELD AND BOTTOM SHEET	110-6
4G3	DRIVE IDLER, TAILINGS AUGER	130-20	2G15	FEEDER HOUSE GUARDS.....	80-30
4G5	DRIVE IDLER, TAILINGS AUGER	130-22			
4E18	DRIVE IDLERS, STRAW CHOPPER.....	120-90			
4H21	DRIVE LINKAGE, UNLOADING AUGER	130-66			

1A16

4425 COMBINE

ALPHABETICAL INDEX - CONTINUED

GRID	PAGE	GRID	PAGE		
3G7	FEEDER HOUSE LOWER BEARINGS AND SPROCKETS, LEFT-HAND.....	4H6	GRAIN TANK PADDLE	110-26	130-50
3F17	FEEDER HOUSE UPPER SHAFT AND SPROCKETS	4G13	GRAIN TANK SHEETS	110-12	130-30
3F19	FEEDER HOUSE UPPER SHEAVE AND SPROCKETS	4H3	GRAIN TANK UNLOADING DRIVE	110-14	130-47
1I3	FIELD LIGHTS	4H4	GRAIN TANK UNLOADING DRIVE SHAFT AND BEARINGS	40-70	130-48
1H19	FILL INDICATOR, GRAIN TANK	4G15	GRAIN TANK WINDOWS AND HANDRAIL	40-62	130-32
1K11	FINAL DRIVE GEARS	2E6	GROUND DRIVE HYDRAULIC LINES	50-34	70-28
1K9	FINAL DRIVE HOUSINGS	1H4	GROUND SPEED INDICATOR SENSOR	50-32	40-47
4B20	FINGER GRATE	4F5	GUARD (RIGHT-HAND), STRAW SPREADER.....	120-14	120-102
2D20	FITTINGS, MAIN CONTROL VALVE.....	4F3	GUARDS (LEFT-HAND), STRAW SPREADER.....	70-16	120-100
3D11	FLOOR MATS.....	4H10	GUARDS, OUTER UNLOADING AUGER HOUSING.....	90-56	130-55
2G7	FLOOR SHEETS, ENGINE COMPARTMENT			80-22	
2F1	FLOW CONTROL VALVE REPAIR KIT, HYDROSTATIC REEL DRIVE		H	70-49	
2E25	FLOW CONTROL VALVE, HYDROSTATIC REEL DRIVE	4G15	HANDRAIL, GRAIN TANK	70-48	130-32
1C10	FLYWHEEL	3B12	HANDRAILS, OPERATOR'S PLATFORM	20-31	90-6
1C9	FLYWHEEL HOUSING	3E7	HARDWARE KIT, COMPRESSOR	20-30	90-78
2B12	FOOT BRAKES, DISK BRAKES	1H15	HARNESSES, LOW SHAFT SPEED MONITOR STRAW CHOPPER	60-10	40-58
4C16	FRAME, CHAFFER	1I5	HARNESSES, REEL DRIVE.....	120-36	40-72
4E10	FRAME, STRAW CHOPPER	1H21	HARVESTRAK SENSORS.....	120-82	40-64
2F14	FRONT AXLE SUPPORT.....	1H23	HARVESTRAK WIRING HARNESSES	80-4	40-66
3E17	FRONT CONDENSER FAN.....	1B14	HEAD, CYLINDER	90-88	20-10
1B11	FRONT PLATE	3F15	HEADER ATTACHING PIN	20-7	110-10
2G23	FRONT SEPARATOR SHIELDS, LEFT-HAND	3G1	HEADER DRIVE CHAIN	80-38	110-20
3F12	FRONT SHIELD, FEEDER HOUSE	3G9	HEADER DRIVE SHAFT	110-6	110-28
1D15	FUEL FILTER AND LINES.....	2G17	HEADER LIFT CYLINDER SAFETY STOP	30-4	80-32
1D16	FUEL FILTER AND LINES.....	2E5	HEADER LIFT HYDRAULIC CYLINDER.....	30-5	70-27
1D22	FUEL INJECTION LINES.....	2E8	HEADER LIFT HYDRAULIC LINES.....	30-11	70-30
1D23	FUEL INJECTION NOZZLE	3F4	HEADERS	30-12	100-A02
1D21	FUEL INJECTION PUMP	1G9	HEADLIGHTS, HORN	30-10	40-28
1D15	FUEL LINES AND FILTER.....	3D17	HEADLINER	30-4	90-62
1D16	FUEL LINES AND FILTER.....	3E3	HEATER VALVE AND HOSES	30-5	90-74
1E10	FUEL PRE-FILTER.....	1C20	HEATER, ENGINE COOLANT.....	30-24	20-42
1E14	FUEL PRE-FILTER, GASKET-SET	1G9	HORN AND HEADLIGHTS	30-28	40-28
1E12	FUEL PRE-FILTER, REPAIR-SET.....	3E15	HOSES AND COUPLERS, AIR CONDITIONING	30-26	90-86
1E7	FUEL TANK	4H13	HOUSING AND OUTER UNLOADING AUGER	30-20	130-58
1D19	FUEL TRANSFER PUMP (SOFABEX)	1G1	HOUSING, CENTRAL ELECTRICAL.....	30-8	40-20
1D17	FUEL TRANSFER PUMP "CORONA".....	4G1	HOUSING, GRAIN TANK LOADING AUGER	30-6	130-18
1D18	FUEL TRANSFER PUMP "SOFABEX"	4F10	HOUSING, LOWER TAILINGS AND CLEAN GRAIN AUGERS.....	30-7	130-2
1D20	FUEL TRANSFER PUMP(REPLACEMENT)	1C17	HOUSING, THERMOSTAT.....	30-9	20-39
1E9	FUEL TRANSFER PUMP, ELECTRICAL	1C9	HOUSING, FLYWHEEL	30-22	20-30
1G3	FUSES AND STRIP TERMINAL	1I18	HOUSINGS FOR ELECTRICAL PLUG CONNECTORS.....	40-22	40-86
		4H19	HYDRAULIC CYLINDER MOUNTING, SWING, UNLOADING AUGER		130-64
	G	2E5	HYDRAULIC CYLINDER, HEADER LIFT		70-27
1C18	GASKET SET	2E3	HYDRAULIC CYLINDER, UNLOADING AUGER SWING		70-24
1C18	GASKET SET ENGINE	2E12	HYDRAULIC HOSE, REEL LIFT		70-34
2E22	GASKET SET FOR REEL DRIVE HYDRAULIC PUMP	2E17	HYDRAULIC LINE, VARIABLE DRIVE WITH CENTER OIL SUPPLY FOR BEATER		70-40
2D9	GASKET SET, MAIN HYDRAULIC PUMP "CESSNA" TYPE 200100 LFY	2F3	HYDRAULIC LINES AND HOSES, HYDROSTATIC REEL DRIVE		70-52
1E14	GASKET-SET, FUEL PRE-FILTER	4I7	HYDRAULIC LINES, DIAL-A-MATIC		140-6
1K1	GEAR SHIFTING PARTS.....	2E6	HYDRAULIC LINES, GROUND DRIVE		70-28
1B23	GEAR, TIMING COVER.....	2E8	HYDRAULIC LINES, HEADER LIFT		70-30
1B24	GEAR, TIMING COVER	2D12	HYDRAULIC LINES, MAIN, (RESERVOIR, PUMP, CONTROL VALVE)		70-8
1B19	GEARS, IDLE	2E10	HYDRAULIC LINES, REEL LIFT		70-32
1B20	GEARS, IDLE	2E1	HYDRAULIC LINES, REVERSE DRIVE		70-22
4C14	GRAIN PAN	2E15	HYDRAULIC LINES, UNLOADING AUGER		70-38
4C24	GRAIN PAN SHAFT AND SUSPENSION.....	2E21	HYDRAULIC PUMP, REEL DRIVE		70-44
4G11	GRAIN TANK	2E22	HYDRAULIC PUMP, GASKET SET, REEL DRIVE		70-45
4G17	GRAIN TANK ACCESS DOOR	2E23	HYDRAULIC RESERVOIR, REEL DRIVE FITTINGS.....		70-46
1H19	GRAIN TANK FILL INDICATOR	3G3	HYDRAULIC REVERSE DRIVE		110-22
4G22	GRAIN TANK INNER UNLOADING AUGER.....	3G5	HYDRAULIC REVERSE SHIFTER		110-24
4G24	GRAIN TANK INNER UNLOADING AUGER.....				
4H1	GRAIN TANK LEVELING AUGER.....				
4G1	GRAIN TANK LOADING AUGER AND HOUSING.....				

1A17

4425 COMBINE

ALPHABETICAL INDEX - CONTINUED

<i>GRID</i>	<i>PAGE</i>	<i>GRID</i>	<i>PAGE</i>					
3C7	HYDRAULIC REVERSER, CONTROL LEVER - CUTTING PLATFORM.....	4F14	LOWER CLEAN GRAIN ELEVATOR HOUSING	90-26	130-6			
2E4	HYDRAULIC SWING UNLOADING AUGER CYLINDER	4D11	LOWER FAN VARIABLE SHEAVES	70-25	120-56			
2F5	HYDROSTATIC REEL DRIVE - MODIFICATION PARTS FOR 900 SERIES CUTTING PLATFORMS	3G11	LOWER REEL DRIVE	70-54	110-30			
2E25	HYDROSTATIC REEL DRIVE FLOW CONTROL VALVE	3G13	LOWER REEL DRIVE GUARDS	70-48	110-32			
2F1	HYDROSTATIC REEL DRIVE FLOW CONTROL VALVE REPAIR KIT.....	4F12	LOWER TAILINGS AND CLEAN GRAIN AUGERS	70-49	130-4			
2F2	HYDROSTATIC REEL DRIVE MOTOR.....	4F10	LOWER TAILINGS AND CLEAN GRAIN AUGERS HOUSING	70-50	130-2			
2F3	HYDROSTATIC REEL DRIVE, HYDRAULIC LINES AND HOSES	4F12	LOWER TAILINGS, CLEAN GRAIN AUGERS	70-52	130-4			
		4F10	LOWER TAILINGS, HOUSING		130-2			
I								
1B19	IDLE GEARS	M		1B22	MAGNETIC PICK UP	20-15	20-18	
1B20	IDLE GEARS	2D14	MAIN CONTROL VALVE	2D18	MAIN CONTROL VALVE KIT	20-16	70-10	
4C6	IDLER ARM, SEPARATOR DRIVE	2D20	MAIN CONTROL VALVE FITTINGS	2D16	MAIN CONTROL VALVE POPPETS	120-26	70-16	
4C8	IDLER, SEPARATOR DRIVE	2D12	MAIN HYDRAULIC LINES (RESERVOIR, PUMP, CONTROL VALVE)	2D12	MAIN HYDRAULIC LINES (RESERVOIR, PUMP, CONTROL VALVE)	120-28	70-8	
2B21	INDIVIDUAL PARTS FOR STEERING PUMP	2D8	MAIN HYDRAULIC PUMP "CESSNA" TYPE 200100 LFY	2D8	MAIN HYDRAULIC PUMP "CESSNA" TYPE 200100 LFY	60-20	70-4	
2C1	INDIVIDUAL PARTS FOR STEERING PUMP	2D10	MAIN HYDRAULIC PUMP DRIVE AND MOUNTING	2D9	MAIN HYDRAULIC PUMP GASKET SET "CESSNA" TYPE 200100 LFY	60-24	70-6	
1I1	INFORMATION PANEL	2D6	MAIN HYDRAULIC RESERVOIR	1D13	MANIFOLD, AIR INTAKE	40-68	70-5	
3D15	INNER ROOF AND COVERS	1D14	MANIFOLD, EXHAUST	1D14	MANIFOLD, EXHAUST	90-60	30-2	
4H8	INNER UNLOADING AUGER AND PADDLE DRIVES.....	1C17	MANIFOLD, WATER.....	4I5	MECHANICAL PARTS, DIAL-A-MATIC	130-52	30-3	
4G18	INNER UNLOADING AUGER COVERS	2F5	MODIFICATION PARTS FOR HYDROSTATIC REEL DRIVE	2F5	MODIFICATION PARTS FOR HYDROSTATIC REEL DRIVE	130-36	70-54	
4G20	INNER UNLOADING AUGER COVERS	3C23	MOLDINGS, CAB	3C23	MOLDINGS, CAB	130-38	90-44	
4G24	INNER UNLOADING AUGER, GRAIN TANK	1D8	MOTOR PULLEY	1D8	MOTOR PULLEY	40-44	20-56	
1H1	INSTRUMENT PANEL	2D22	MOTOR, HYDRAULIC, REVERSE DRIVE	2D22	MOTOR, HYDRAULIC, REVERSE DRIVE	40-44	70-18	
1H3	INSTRUMENT PANEL, WIRING HARNESS	2D24	MOTOR, HYDRAULIC, REVERSE DRIVE	2D24	MOTOR, HYDRAULIC, REVERSE DRIVE	40-46	70-20	
1D24	INTAKE TUBES, PRECLEANER	2F2	MOTOR, HYDROSTATIC REEL DRIVE	2F2	MOTOR, HYDROSTATIC REEL DRIVE	30-13	70-50	
K				1F10	MOTOR, STARTING.....		40-4	
2D18	KIT, MAIN CONTROL VALVE	1C21	MOUNTING PARTS, ENGINE	1C21	MOUNTING PARTS, ENGINE	70-14	20-43	
1C2	KIT, LINER AND PISTON	1I8	MOUNTING PARTS, RADIO AND SPEAKERS	1I8	MOUNTING PARTS, RADIO AND SPEAKERS	20-23	40-76	
4E8	KNIVES, STRAW CHOPPER.....	2H11	MOUNTING, ENGINE COMPARTMENT SHEETS	2H11	MOUNTING, ENGINE COMPARTMENT SHEETS	120-80	80-50	
L				2G11	MOUNTINGS, BATTERY		80-26	
2G5	LADDER, REAR SERVICE PLATFORM	1E5	MUFFLER, EXHAUST EJECTOR AND PIPE	1E5	MUFFLER, EXHAUST EJECTOR AND PIPE	80-20	30-18	
4J11	LEFT-HAND DECALS	N				1D23	NOZZLE, FUEL INJECTION	30-12
4J13	LEFT-HAND DECALS	O						
4J15	LEFT-HAND DECALS	1C13	OIL COOLER(10 PLATES)	1C13	OIL COOLER(10 PLATES)	150-22	20-34	
3C5	LEFT-HAND LEVERS.....	1C15	OIL COOLER(8 PLATES).....	1C15	OIL COOLER(8 PLATES).....	150-24	20-36	
2G13	LEFT-HAND REAR SEPARATOR SHIELD.....	1B10	OIL FILTER	1B10	OIL FILTER	150-26	20-6	
2H3	LEFT-HAND SHIELD BRACKET	1J17	OIL LINES, CLUTCH	1J17	OIL LINES, CLUTCH	80-28	50-14	
2H5	LEFT-HAND SHIELD BRACKET	1C8	OIL PAN	1C8	OIL PAN	80-42	20-29	
3C9	LEVERS, CONCAVE AND BRAKE	1C7	OIL PUMP	1C7	OIL PUMP	80-44	20-28	
3C5	LEVERS, LEFT-HAND	3C14	OPERATING CABLES ON OPERATOR'S PLATFORM	3C14	OPERATING CABLES ON OPERATOR'S PLATFORM	90-24	90-34	
1I10	LIGHT, DOME.....	3C12	OPERATING CONTROLS, RIGHT-HAND.....	3C12	OPERATING CONTROLS, RIGHT-HAND.....	40-78	90-32	
1I11	LIGHT, DOME.....	3C20	OPERATOR'S PLATFORM COVER PLATE	3C20	OPERATOR'S PLATFORM COVER PLATE	40-79	90-41	
1I3	LIGHTS, FIELD.....	4J19	OPERATOR'S PLATFORM DECALS	4J19	OPERATOR'S PLATFORM DECALS	40-70	150-30	
1C3	LINER	4J21	OPERATOR'S PLATFORM DECALS	4J21	OPERATOR'S PLATFORM DECALS	20-24	150-32	
1C2	LINER AND PISTON KIT	3B12	OPERATOR'S PLATFORM HANDRAILS	3B12	OPERATOR'S PLATFORM HANDRAILS	20-23	90-6	
1D22	LINES, FUEL INJECTION	3B10	OPERATOR'S PLATFORM LADDER	3B10	OPERATOR'S PLATFORM LADDER	30-11	90-4	
4G1	LOADING AUGER, GRAIN TANK	3B14	OPERATOR'S PLATFORM PARTS.....	3B14	OPERATOR'S PLATFORM PARTS.....	130-18	90-8	
1H17	LOW SHAFT SPEED CONTROL SWITCHES, STRAW CHOPPER	3C19	OPERATOR'S PLATFORM SOUNDPROOFING.....	3C19	OPERATOR'S PLATFORM SOUNDPROOFING.....	40-60	90-40	
1H7	LOW SHAFT SPEED MONITOR (LEFT-HAND) WIRING HARNESS					40-50		
1H9	LOW SHAFT SPEED MONITOR AND HARVESTRAK (RIGHT-HAND) WIRING HARNESS					40-52		
1H15	LOW SHAFT SPEED MONITOR, STRAW CHOPPER HARNESS.....					40-58		

1A18

4425 COMBINE

ALPHABETICAL INDEX - CONTINUED

<i>GRID</i>		<i>PAGE</i>	<i>GRID</i>		<i>PAGE</i>
1G5	OPERATOR'S PLATFORM WIRING HARNESS.....	40-24	2F20	REAR HOOD	80-10
1G7	OPERATOR'S PLATFORM WIRING HARNESS.....	40-26	2F24	REAR HOOD LOWER SHEETS	80-14
3C14	OPERATOR'S PLATFORM, OPERATING CABLES.....	90-34	2G1	REAR HOOD RAILING.....	80-16
3B8	OPERATOR'S PLATFORM	90-2	2F22	REAR HOOD, REINFORCEMENTS	80-12
3B16	OPERATOR'S SEAT	90-11	2G5	REAR SERVICE PLATFORM LADDER	80-20
4H11	OUTER UNLOADING AUGER AND HOUSING	130-56	3B23	REAR VIEW MIRROR	90-18
4H13	OUTER UNLOADING AUGER AND HOUSING	130-58	2C21	REAR WHEELS	60-44
4H10	OUTER UNLOADING AUGER HOUSING GUARDS	130-55	3E13	RECEIVER - DRYER AND HOSES	90-84
4H15	OUTER UNLOADING AUGER UNIVERSAL DRIVE.....	130-60	4B24	REDUCTION TRANSMISSION, VARIABLE CYLINDER SHEAVES	120-18
4H17	OUTER UNLOADING AUGER UNIVERSAL DRIVE.....	130-62	2E23	REEL DRIVE FITTINGS AND HYDRAULIC RESERVOIR.....	70-46
P					
4H8	PADDLE DRIVES, INNER UNLOADING AUGER.....	130-52	1I5	REEL DRIVE HARNESS	40-72
4H6	PADDLE, GRAIN TANK	130-50	2E21	REEL DRIVE HYDRAULIC PUMP.....	70-44
3D19	PANEL, AIR OUTLET.....	90-64	2E22	REEL DRIVE HYDRAULIC PUMP, GASKET SET	70-45
3E9	PARTS, COMPRESSOR	90-80	2E12	REEL LIFT HYDRAULIC HOSE	70-34
2B4	PEDALS, BRAKE	60-2	2E10	REEL LIFT, HYDRAULIC LINES	70-32
1B22	PICK UP,MAGNETIC	20-18	2F22	REINFORCEMENTS, REAR HOOD	80-12
1C3	PISTON.....	20-24	1G4	RELAY PLUG SOCKET	40-23
3G17	PLATFORM ADAPTER PLATES	110-36	1E12	REPAIR-SET, FUEL PRE-FILTER.....	30-26
2H15	PLUGGED CYLINDER TOOL	80-54	1B15	RETAINERS	20-11
2D16	POPPETS, MAIN CONTROL VALVE	70-12	4C20	RETURN PAN WITH SIEVES	120-40
4B22	POSI TORQ VARIABLE CYLINDER SHEAVES	120-16	3F11	RETURN SHIELDS, FEEDER CONVEYOR	110-4
1J7	POSI-TORQ COUNTERSHAFT AND ARM (UPPER UNIT)	50-4	2E1	REVERSE DRIVE HYDRAULIC LINES.....	70-22
1J11	POSI-TORQ SHEAVES (LOWER UNIT).....	50-8	2D22	REVERSE DRIVE HYDRAULIC MOTOR	70-18
1J9	POSI-TORQ SHEAVES (UPPER UNIT)	50-6	2D24	REVERSE DRIVE HYDRAULIC MOTOR	70-20
1J5	POSI-TORQ SUPPORTS (UPPER UNIT).....	50-2	4J5	RIGHT-HAND DECALS	150-16
1E10	PRE-FILTER, FUEL	30-24	4J7	RIGHT-HAND DECALS	150-18
1D24	PRECLEANER AND AIR INTAKE TUBES	30-13	4J9	RIGHT-HAND DECALS	150-20
2E19	PRESSURE INDICATOR HOSE, CUTTING PLATFORM	70-42	1B16	ROCKER ARM	20-12
1A2	PRIMARY PICTORIAL INDEX	10-1	1B13	ROCKER ARM COVER	20-9
1A3	PRIMARY PICTORIAL INDEX	10-2	1B16	ROCKER ARM SHAFT.....	20-12
1A4	PRIMARY PICTORIAL INDEX	10-3	1C24	ROTARY RADIATOR SCREEN	20-46
1A5	PRIMARY PICTORIAL INDEX	10-4	1D2	ROTARY RADIATOR SCREEN, COUNTERSHAFT	20-50
1A6	PRIMARY PICTORIAL INDEX	10-5	1D1	ROTARY RADIATOR SCREEN, SUCTION NOZZLE	20-48
1A7	PRIMARY PICTORIAL INDEX	10-6	4E8	ROTOR, STRAW CHOPPER.....	120-80
1D8	PULLEY, MOTOR.....	20-56	S		
1C6	PULLEY,AUXILIARY.....	20-27	2B23	SEAL KIT, STEERING PUMP	60-22
1C5	PULLEY,CRANKSHAFT	20-26	3B16	SEAT	90-11
1D19	PUMP, FUEL TRANSFER (SOFABEX).....	30-8	3B21	SEAT ADJUSTMENT	90-16
1D17	PUMP, FUEL TRANSFER "CORONA"	30-6	3B17	SEAT CUSHIONS.....	90-12
1D18	PUMP, FUEL TRANSFER "SOFABEX".....	30-7	3B19	SEAT MOUNTING	90-14
1D20	PUMP, FUEL TRANSFER(REPLACEMENT)	30-9	3B15	SEAT SUPPORT	90-10
1E9	PUMP, FUEL TRANSFER, ELECTRICAL	30-22	1B3	SECTIONAL PICTORIAL INDEX	20-A01
1C7	PUMP, OIL	20-28	1B4	SECTIONAL PICTORIAL INDEX	20-A02
1D21	PUMP,FUEL INJECTION	30-10	1B5	SECTIONAL PICTORIAL INDEX	20-A03
1B16	PUSH RODS.....	20-12	1D11	SECTIONAL PICTORIAL INDEX	30-A02
R					
1C22	RADIATOR	20-44	1D12	SECTIONAL PICTORIAL INDEX	30-A03
1C24	RADIATOR SCREEN, ROTARY	20-46	1F3	SECTIONAL PICTORIAL INDEX	40-A01
1I8	RADIO AND SPEAKERS MOUNTING PARTS.....	40-76	1F4	SECTIONAL PICTORIAL INDEX	40-A02
1I6	RADIO WIRING HARNESS	40-74	1F5	SECTIONAL PICTORIAL INDEX	40-A03
4B13	RASP BAR CYLINDER	120-6	1F6	SECTIONAL PICTORIAL INDEX	40-A04
4B15	RASP BAR CYLINDER SHAFT	120-9	1F7	SECTIONAL PICTORIAL INDEX	40-A05
2C15	REAR AXLE	60-38	1J2	SECTIONAL PICTORIAL INDEX	50-A01
2C13	REAR AXLE FRAME AND SUPPORT	60-36	1J3	SECTIONAL PICTORIAL INDEX	50-A02
2C17	REAR AXLE SPINDLES.....	60-40	1J4	SECTIONAL PICTORIAL INDEX	50-A03
2C11	REAR AXLE, AXLE SUPPORT AND V-SUPPORT	60-34	2B2	SECTIONAL PICTORIAL INDEX	60-A02
3E18	REAR CONDENSER FAN	90-90	2B3	SECTIONAL PICTORIAL INDEX	60-A03
4J17	REAR DECALS.....	150-28	2D3	SECTIONAL PICTORIAL INDEX	70-A02
			2D4	SECTIONAL PICTORIAL INDEX	70-A03
			2D5	SECTIONAL PICTORIAL INDEX	70-A04
			2F9	SECTIONAL PICTORIAL INDEX	80-A02
			2F10	SECTIONAL PICTORIAL INDEX	80-A03
			2F11	SECTIONAL PICTORIAL INDEX	80-A04

1A20

4425 COMBINE

ALPHABETICAL INDEX - CONTINUED

<i>GRID</i>		<i>PAGE</i>	<i>GRID</i>	<i>PAGE</i>
4G22	UNLOADING AUGER, INNER, GRAIN TANK	130-40		
4H13	UNLOADING AUGER, OUTER, AND HOUSING	130-58		
4H11	UNLOADING AUGER, OUTER, HOUSING.....	130-56		
4H15	UNLOADING AUGER, OUTER, UNIVERSAL DRIVE.....	130-60		
4H17	UNLOADING AUGER, OUTER, UNIVERSAL DRIVE.....	130-62		
4H3	UNLOADING DRIVE, GRAIN TANK	130-47		
4H4	UNLOADING DRIVE, GRAIN TANK	130-48		
4F20	UPPER CLEAN GRAIN ELEVATOR	130-12		
4D7	UPPER FAN VARIABLE DRIVE SUPPORT	120-52		
4D9	UPPER FAN VARIABLE SHEAVES	120-54		
2G17	UPPER TAILINGS ELEVATOR GUARD	80-32		
V				
1B15	VALVE SEATS	20-11		
1B15	VALVES	20-11		
4B22	VARIABLE CYLINDER SHEAVES, POSI TORQ	120-16		
4B24	VARIABLE CYLINDER SHEAVES, REDUCTION TRANSMISSION.....	120-18		
4C1	VARIABLE CYLINDER SUSPENSION	120-20		
4D7	VARIABLE DRIVE SUPPORT, UPPER FAN	120-52		
4C4	VARIABLE DRIVE WITH CENTER OIL SUPPLY FOR BEATER.....	120-24		
2E17	VARIABLE DRIVE WITH CENTER OIL SUPPLY FOR BEATER HYDRAULIC LINE	70-40		
4D11	VARIABLE SHEAVES, LOWER FAN	120-56		
4D9	VARIABLE SHEAVES, UPPER FAN	120-54		
1B12	VENT TUBE	20-8		
3D5	VISOR AND DOOR HANDLE	90-50		
W				
1G11	WARNING LIGHTS AND TAIL LIGHTS	40-30		
1H5	WARNING SYSTEM, STRAW WALKER.....	40-48		
1C17	WATER MANIFOLD	20-39		
1C11	WATER PUMP, FAN AND BELTS	20-32		
1K15	WHEELS, DRIVE	50-38		
4G15	WINDOWS, GRAIN TANK	130-32		
1I14	WINDSHIELD WIPERS	40-82		
1I14	WIPERS, WINDSHIELD	40-82		
1H11	WIRING HARNESS	40-54		
1H3	WIRING HARNESS - INSTRUMENT PANEL	40-46		
1G13	WIRING HARNESS, BASIC	40-32		
1G15	WIRING HARNESS, BASIC	40-34		
1G17	WIRING HARNESS, BASIC	40-36		
1G19	WIRING HARNESS, BASIC	40-38		
1G21	WIRING HARNESS, BASIC	40-40		
1G23	WIRING HARNESS, BASIC	40-42		
1F16	WIRING HARNESS, ENGINE	40-10		
1H7	WIRING HARNESS, LOW SHAFT SPEED MONITOR (LEFT-HAND)	40-50		
1H9	WIRING HARNESS, LOW SHAFT SPEED MONITOR AND HARVESTRAK (RIGHT-HAND)	40-52		
1G5	WIRING HARNESS, OPERATOR'S PLATFORM	40-24		
1G7	WIRING HARNESS, OPERATOR'S PLATFORM	40-26		
1I6	WIRING HARNESS, RADIO.....	40-74		
1H23	WIRING HARNESSES, HARVESTRAK.....	40-66		
1I12	WIRING, CAB ROOF	40-80		

