

POWERTECH® 4.5L & 6.8L Diesel Engines

Base Engine

COMPONENT TECHNICAL MANUAL

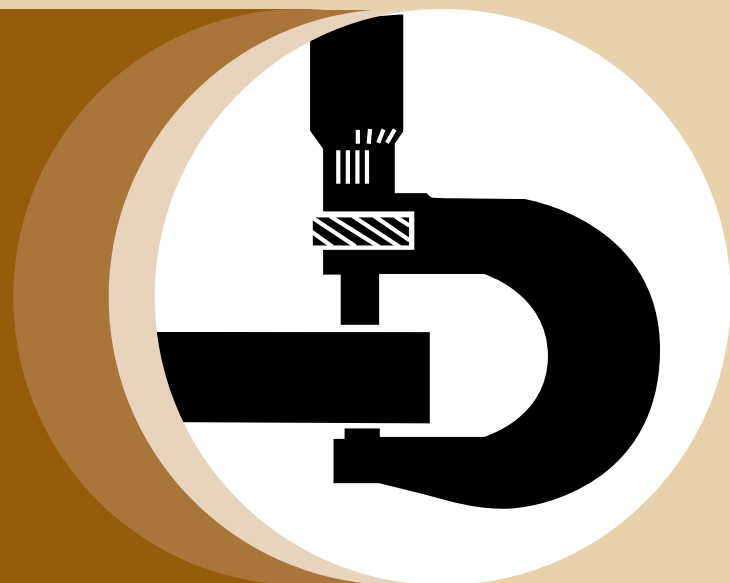

For complete service information also see:

<i>POWERTECH</i> ® 4.5 L and 6.8 L Diesel Engines—Level 4 Electronic Fuel Systems with Bosch VP44 Pump	CTM170
<i>POWERTECH</i> ® 4.5 L and 6.8 L Diesel Engines—Mechanical Fuel Systems.....	CTM207
Alternators and Starting Motors	CTM77
OEM Engine Accessories.....	CTM67 (English Only)

Deere Power Systems Group
CTM104 (19JUN00)

LITHO IN U.S.A.
ENGLISH



Introduction

Forward

This manual is written for an experienced technician. Essential tools required in performing certain service work are identified in this manual and are recommended for use.

This manual (CTM104) covers only the base engine. It is one of three volumes on 4.5 L and 6.8 L engines. The following two companion manuals cover fuel system repair, operation and diagnostics:

- CTM170—Level 4 Electronic Fuel Systems with Bosch VP44 Pump
- CTM207—Mechanical Fuel Systems

CTM207 covers the fuel systems formerly included in CTM104.

Other manuals will be added in the future to provide additional information on electronic fuel systems as needed.

A complete set of all three manuals covering the 4.5 L and 6.8 L engines can be procured by ordering CTM350 Binder Set.

Live with safety: Read the safety messages in the introduction of this manual and the cautions presented throughout the text of the manual.



This is the safety-alert symbol. When you see this symbol on the machine or in this manual, be alert to the potential for personal injury.

Use this component technical manual in conjunction with the machine technical manual. An application listing in Section 01, Group 001 identifies product-model/component type-model relationship. See

the machine technical manual for information on component removal and installation, and gaining access to the components.

Information is organized in sections and groups for the various components requiring service instruction. At the beginning of each group are summary listings of all applicable essential tools, service equipment and tools, other materials needed to do the job, service parts kits, specifications, wear tolerances, and torque values.

Before beginning repair on an engine, clean the engine and mount on a repair stand. (See Section 2, Group 010.)

This manual contains SI Metric units of measure followed immediately by the U.S. customary units of measure. Most hardware on these engines is metric sized.

Some components of this engine may be serviced without removing the engine from the machine. Refer to the specific machine technical manual for information on components that can be serviced without removing the engine from the machine and for engine removal and installation procedures.

Read each block of material completely before performing service to check for differences in procedures or specifications. Follow only the procedures that apply to the engine model number you are working on. If only one procedure is given, that procedure applies to all the engines in the manual.

CALIFORNIA PROPOSITION 65 WARNING

Diesel engine exhaust and some of its constituents are known to the State of California to cause cancer, birth defects and other reproductive harm.

DPSG,OUO1004,2767 -19-18MAY00-1/1

John Deere Dealers

The changes listed below make your CTM obsolete. Repair, operation and diagnostics on 4.5L and 6.8 L diesel engines is now covered in three manuals.

Discard CTM104 dated 12OCT98 and replace with the following new manuals:

- CTM104 4.5 L and 6.8 L Diesel Engines—Base Engine
- CTM207 4.5 L and 6.8 L Diesel Engines—Mechanical Fuel Systems
- CTM170 4.5 L and 6.8 L Diesel Engines—Level 4 Electronic Fuel System with Bosch VP44 Pump

Also, copy this page listing changes and route through your Service Department.

SECTION 01—GROUP 001 (Engine Identification)

- Updated engine model designation chart.
- Updated engine application charts.

SECTION 01—GROUP 002 (Fuels Lubricants and Coolants)

- Updated engine oil and coolant application guidelines.

SECTION 02—GROUP 010 (Engine Rebuild)

- Updated engine lifting procedure and safety precautions.
- Updated sealant application guidelines.
- Added engine break-in procedure.

SECTION 02—GROUP 020 (Cylinder Head and Valves)

- Revised rocker arm support torque specifications.

SECTION 02—GROUP 030 (Cylinder Block, Liners, Pistons and Rods)

- Updated procedure for determining piston-to-liner clearance.
- Added sealant requirements and torque specifications for plugs and caps in cylinder block,

located in procedure for inspection and cleaning of cylinder block.

- Revised procedure for measuring cylinder liner standout (height above block).
- Revised procedure for installing cylinder liners in block.

SECTION 02—GROUP 040 (Crankshaft, Main Bearings and Flywheel)

- Revised procedure and specifications for removal and installation of vibration damper.
- Revised procedure for removal and installation of front oil seal and wear sleeve.
- Revised procedure for installation of flywheel.
- Revised procedure and specifications for installation of flywheel housing.
- Added procedure for removal and installation of crankshaft timing wheel on engines with Bosch VP44 fuel injection pump.

SECTION 02—GROUP 050 (Camshaft, Balancer Shafts and Timing Gear Train)

- Revised idler gear end play specifications.
- Updated timing gear backlash specifications.
- Revised procedure for removal and installation of balancer shafts.
- Revised idler gear bushing and idler gear shaft specifications.
- Revised procedure for installation of upper idler shaft in front plate.
- Revised procedure for installation of camshaft.
- Revised procedure for installation of timing gear cover.
- Revised procedure for installation of crankshaft front wear sleeve and oil seal.

SECTION 02—GROUP 060 (Lubrication System)

- Revised procedure for removal and installation of oil filter base.
- Revised procedure for removal and installation of oil cooler assembly.
- Revised oil pan drain plug specifications.

SECTION 02—GROUP 070 (Cooling System)

- Added procedure for removal and installation of water manifold/thermostat cover on 6010 Series Tractors.
- Revised torque specification for water pump pulley.
- Revised procedure for installation of fan assembly.
- Revised procedure for installation of fan drive assembly.
- Added procedure for removal and installation of cold start advance switch.

SECTION 02—GROUP 080 (Air Intake and Exhaust System)

- Revised turbocharger lube line torque specifications.
- Added procedure for removal and installation of ether start aid.

SECTION 02—GROUP 090 (Fuel System)

NOTE: Repair procedures for fuel systems has been moved to Section 02, Group 090 in two other technical manuals: CTM207—Mechanical Fuel Systems and CTM170—Level 4 Electronic Fuel Systems with Bosch VP44 Pump.

SECTION 02—GROUP 100 (Starting and Charging Systems)

- Starting and charging systems are now covered in this new section/group.

SECTION 03—GROUP 120 (Base Engine Operation)

- Base engine theory of operation is covered in this new section/group.

NOTE: Fuel system theory of operation has been moved to Section 03, Group 130 in two other technical manuals: CTM207—Mechanical Fuel Systems and CTM170—Level 4 Electronic Fuel Systems with Bosch VP44 Pump.

SECTION 04—GROUP 150 (Observable Diagnostics and Tests)

- Base engine observable tests and diagnostics is covered in this new section/group.
- Added dynamometer test procedure and specifications.

NOTE: Fuel system testing and diagnostics has been moved to Section 04, Group 150 in two other technical manuals: CTM207—Mechanical Fuel Systems and CTM170—Level 4 Electronic Fuel Systems with Bosch VP44 Pump.

SECTION 5 (Tools and Other Materials)

- All essential tools, service tools, dealer fabricated tools and other materials listed throughout this manual are consolidated in this section for ease of reference.

SECTION 6 (Specifications)

- All repair, test and diagnostic specifications listed throughout this manual are consolidated in this section for ease of reference.

POWERTECH[®] 4.5 L Engine

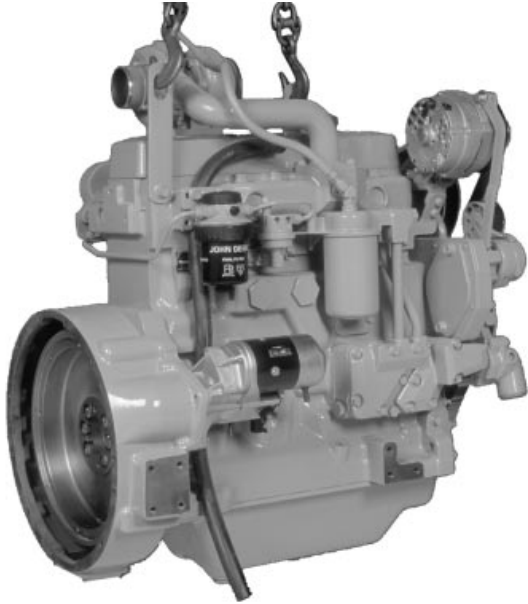

3/4 Right Rear View

RG7636 -UN-23NOV97



3/4 Left Rear View

RG7638 -UN-23NOV97

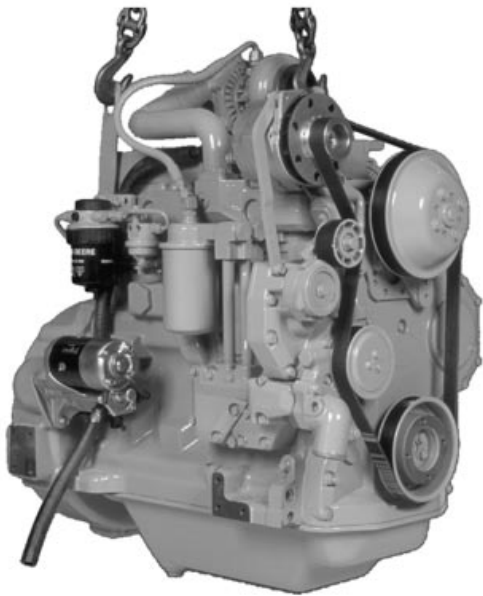

3/4 Right Front View

RG7639 -UN-23NOV97

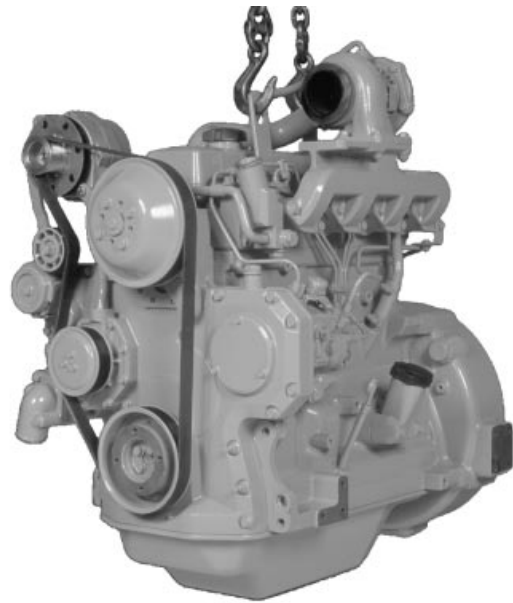

3/4 Left Front View

RG7637 -UN-23NOV97

POWERTECH is a registered trademark of Deere & Company

DPSG,OUO1004,129 -19-15MAY98-1/1

POWERTECH® 6.8 L Engine

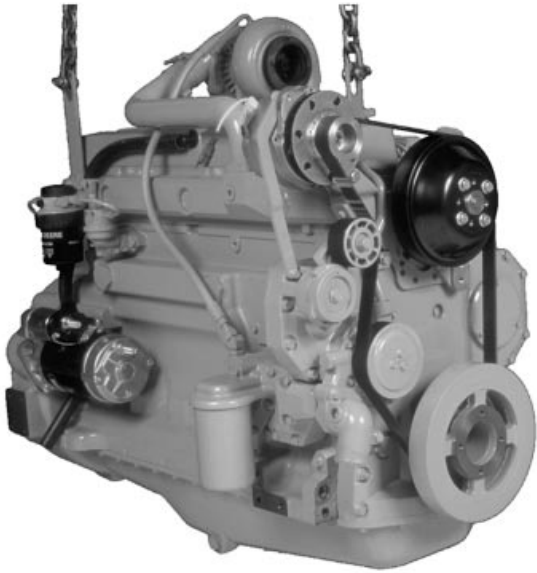

3/4 Right Front View

RG7641 -UN-23NOV97

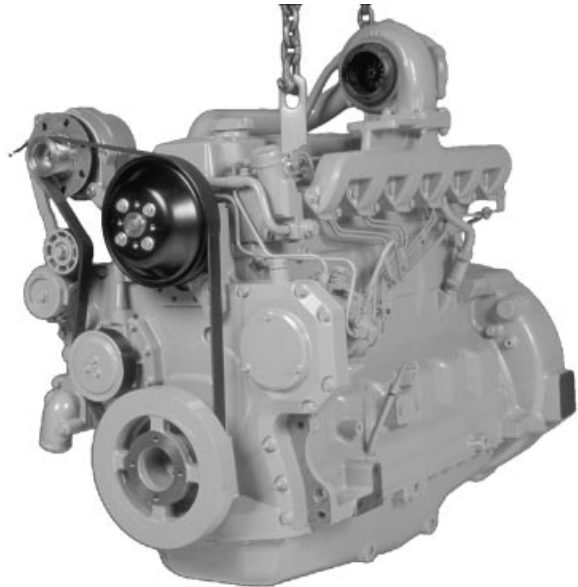

3/4 Left Front View

RG7640 -UN-23NOV97

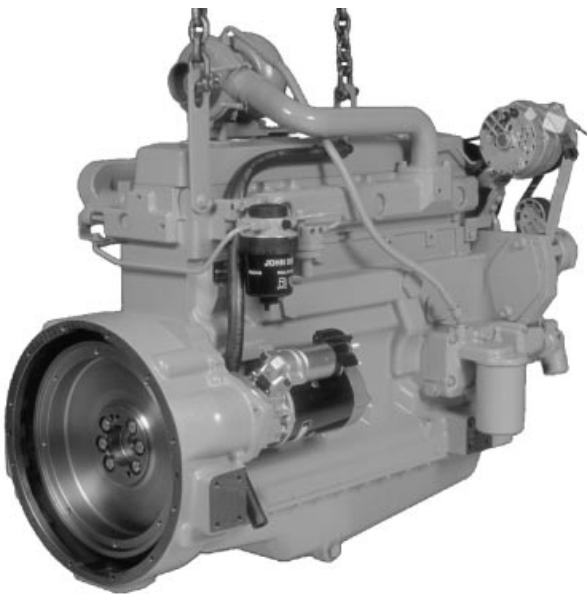

3/4 Right Rear View

RG7643 -UN-23NOV97

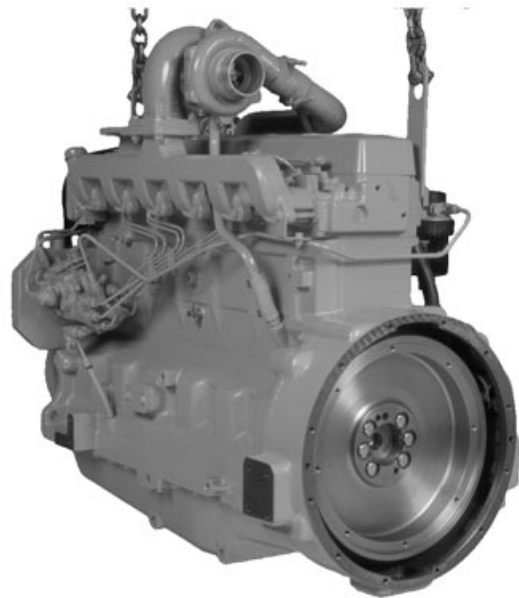

3/4 Left Rear View

RG7642 -UN-23NOV97

POWERTECH is a registered trademark of Deere & Company

DPSG,OUO1004,130 -19-15MAY98-1/1

Contents

SECTION 01—General Information

- Group 000—Safety
- Group 001—Engine Identification
- Group 002—Fuels, Lubricants and Coolants

SECTION 02—Repair and Adjustments

- Group 010—Engine Rebuild
- Group 020—Cylinder Head and Valves
- Group 030—Cylinder Block, Liners, Pistons and Rods
- Group 040—Crankshaft, Main Bearings and Flywheel
- Group 050—Camshaft, Balancer Shafts and Timing Gear Train
- Group 060—Lubrication System
- Group 070—Cooling System
- Group 080—Air Intake and Exhaust System
- Group 090—Fuel System
- Group 100—Starting and Charging Systems

SECTION 03—Theory of Operation

- Group 120—Base Engine Operation

SECTION 04—Diagnostics

- Group 150—Observable Diagnostics and Tests

SECTION 05—Tools and Other Materials

- Group 170—Repair Tools and Other Materials
- Group 180—Diagnostic Service Tools
- Group 190—Dealer Fabricated Service Tools

SECTION 06—Specifications

- Group 200—Repair and General OEM Specifications
- Group 210—Diagnostic Specifications

01

02

03

04

05

06

INDX

All information, illustrations and specifications in this manual are based on the latest information available at the time of publication. The right is reserved to make changes at any time without notice.

COPYRIGHT © 2000
DEERE & COMPANY
Moline, Illinois
All rights reserved
A John Deere ILLUSTRATION® Manual
Previous Editions
Copyright © 1996, 1998

Contents

01

02

03

04

05

06

INDX

Section 01

General Information

Contents

	Page
Group 000—Safety	01-000-1
Group 001—Engine Identification	
Engine Model Designation	01-001-1
Engine Serial Number Plate Information	01-001-2
OEM Engine Option Code Label	01-001-3
Engine Application Charts	01-001-4
Group 002—Fuels, Lubricants and Coolants	
Diesel Fuel	01-002-1
Lubricity of Diesel Fuel	01-002-1
Engine Break-In Oil	01-002-2
Diesel Engine Oil	01-002-3
Extended Diesel Engine Oil Service Intervals	01-002-3
Alternative and Synthetic Lubricants	01-002-4
Mixing of Lubricants	01-002-4
OILSCAN®, OILSCAN Plus® and COOLSCAN™	01-002-5
Grease	01-002-6
Diesel Engine Coolant Recommendations	01-002-7
Engine Coolant Specifications	01-002-8
Testing Diesel Engine Coolant	01-002-11
Replenishing Supplemental Coolant Additives (SCAs) Between Coolant Changes	01-002-12
Operating in Warm Temperature Climates	01-002-13
Flush and Service Cooling System	01-002-14
Disposing of Coolant	01-002-15

Contents

01

Handle Fluids Safely—Avoid Fires

When you work around fuel, do not smoke or work near heaters or other fire hazards.

Store flammable fluids away from fire hazards. Do not incinerate or puncture pressurized containers.

Make sure machine is clean of trash, grease, and debris.

Do not store oily rags; they can ignite and burn spontaneously.



Avoid Fires

TS227 -UN-23AUG88

DX,FLAME -19-29SEP98-1/1

Handle Starting Fluid Safely

Starting fluid is highly flammable.

Keep all sparks and flame away when using it. Keep starting fluid away from batteries and cables.

To prevent accidental discharge when storing the pressurized can, keep the cap on the container, and store in a cool, protected location.

Do not incinerate or puncture a starting fluid container.



Store Safely

TS1356 -UN-18MAR92

DX,FIRE3 -19-16APR92-1/1

01
000
2

Service Cooling System Safely

Explosive release of fluids from pressurized cooling system can cause serious burns.

Shut off engine. Only remove filler cap when cool enough to touch with bare hands. Slowly loosen cap to first stop to relieve pressure before removing completely.



Cooling System

TS281 -UN-23AUG88

DX,RCAP -19-04JUN90-1/1

Prevent Battery Explosions

Keep sparks, lighted matches, and open flame away from the top of battery. Battery gas can explode.

Never check battery charge by placing a metal object across the posts. Use a voltmeter or hydrometer.

Do not charge a frozen battery; it may explode. Warm battery to 16°C (60°F).



Battery Explosions

TS204 -UN-23AUG88

DX,SPARKS -19-03MAR93-1/1

Prepare for Emergencies

Be prepared if a fire starts.

Keep a first aid kit and fire extinguisher handy.

Keep emergency numbers for doctors, ambulance service, hospital, and fire department near your telephone.

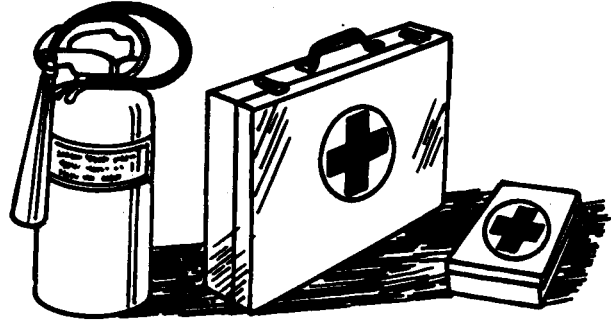

First Aid Kit

01
000
3

T5291 -JUN-23AUG88

DX,FIRE2 -19-03MAR93-1/1

Handling Batteries Safely

! **CAUTION:** Battery gas can explode. Keep sparks and flames away from batteries. Use a flashlight to check battery electrolyte level.

Never check battery charge by placing a metal object across the posts. Use a voltmeter or hydrometer.

Always remove grounded (-) battery clamp first and replace it last.

! **CAUTION:** Sulfuric acid in battery electrolyte is poisonous. It is strong enough to burn skin, eat holes in clothing, and cause blindness if splashed into eyes.

Avoid the hazard by:

1. Filling batteries in a well-ventilated area.
2. Wearing eye protection and rubber gloves.
3. Avoiding breathing fumes when electrolyte is added.
4. Avoiding spilling or dripping electrolyte.
5. Use proper jump start procedure.

If you spill acid on yourself:

1. Flush your skin with water.
2. Apply baking soda or lime to help neutralize the acid.
3. Flush your eyes with water for 15—30 minutes. Get medical attention immediately.

If acid is swallowed:

1. Do not induce vomiting.
2. Drink large amounts of water or milk, but do not exceed 2 L (2 quarts).
3. Get medical attention immediately.

WARNING: Battery posts, terminals, and related accessories contain lead and lead compounds, chemicals known to the State of California to cause cancer and reproductive harm. **Wash hands after handling.**



TS204 -UN-23AUG88

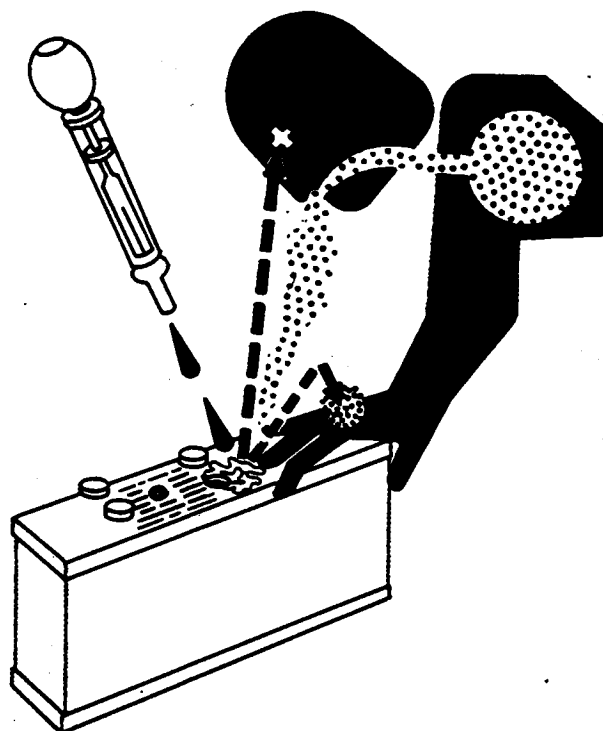

TS203 -UN-23AUG88

Avoid High-Pressure Fluids

Escaping fluid under pressure can penetrate the skin causing serious injury.

Avoid the hazard by relieving pressure before disconnecting hydraulic or other lines. Tighten all connections before applying pressure.

Search for leaks with a piece of cardboard. Protect hands and body from high pressure fluids.

If an accident occurs, see a doctor immediately. Any fluid injected into the skin must be surgically removed within a few hours or gangrene may result. Doctors unfamiliar with this type of injury should reference a knowledgeable medical source. Such information is available from Deere & Company Medical Department in Moline, Illinois, U.S.A.

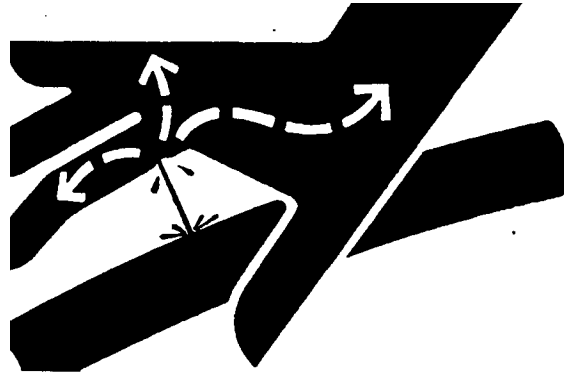

High-Pressure Fluids

X9811 -UN-23AUG88

DX,FLUID -19-03MAR93-1/1

Wear Protective Clothing

Wear close fitting clothing and safety equipment appropriate to the job.

Prolonged exposure to loud noise can cause impairment or loss of hearing.

Wear a suitable hearing protective device such as earmuffs or earplugs to protect against objectionable or uncomfortable loud noises.

Operating equipment safely requires the full attention of the operator. Do not wear radio or music headphones while operating machine.

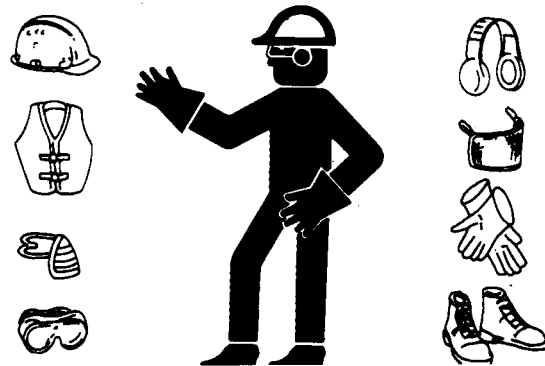

Protective Clothing

T5206 -UN-23AUG88

DX,WEAR -19-10SEP90-1/1

01
000
6

Service Machines Safely

Tie long hair behind your head. Do not wear a necktie, scarf, loose clothing, or necklace when you work near machine tools or moving parts. If these items were to get caught, severe injury could result.

Remove rings and other jewelry to prevent electrical shorts and entanglement in moving parts.

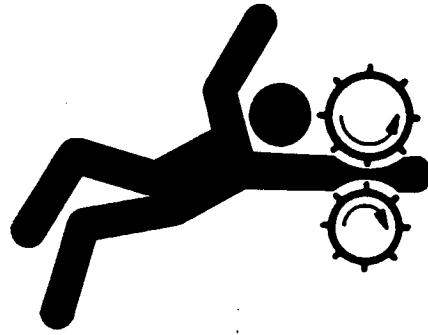

Moving Parts

TS228 -UN-23AUG88

DX, LOOSE -19-04JUN90-1/1

Work In Ventilated Area

Engine exhaust fumes can cause sickness or death. If it is necessary to run an engine in an enclosed area, remove the exhaust fumes from the area with an exhaust pipe extension.

If you do not have an exhaust pipe extension, open the doors and get outside air into the area

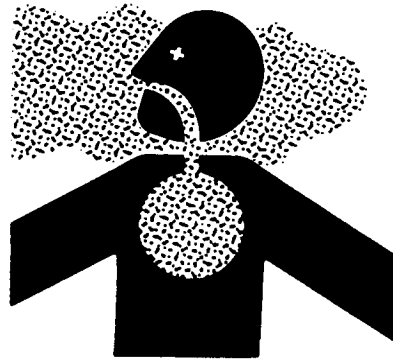

Engine Exhaust Fumes

TS220 -UN-23AUG88

DX, AIR -19-17FEB99-1/1

Work in Clean Area

Before starting a job:

- Clean work area and machine.
- Make sure you have all necessary tools to do your job.
- Have the right parts on hand.
- Read all instructions thoroughly; do not attempt shortcuts.

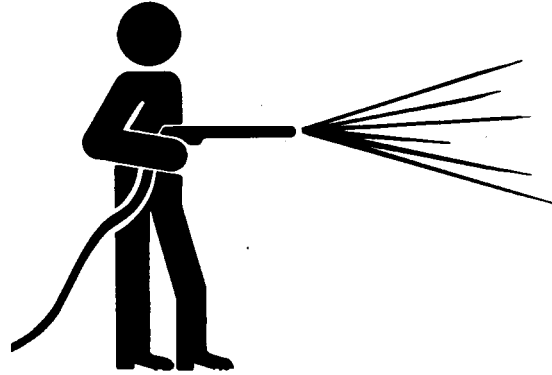

Clean Work Area

TS220 -JUN-18OCT88

DX,CLEAN -19-04JUN90-1/1

Remove Paint Before Welding or Heating

Avoid potentially toxic fumes and dust.

Hazardous fumes can be generated when paint is heated by welding, soldering, or using a torch.

Do all work outside or in a well ventilated area. Dispose of paint and solvent properly.

Remove paint before welding or heating:

- If you sand or grind paint, avoid breathing the dust. Wear an approved respirator.
- If you use solvent or paint stripper, remove stripper with soap and water before welding. Remove solvent or paint stripper containers and other flammable material from area. Allow fumes to disperse at least 15 minutes before welding or heating.

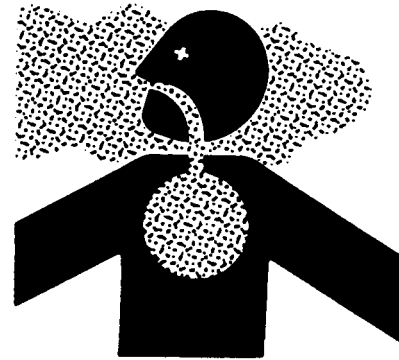

Toxic Fumes

TS220 -JUN-23AUG88

DX,PAINT -19-03MAR93-1/1

01
000
8

Avoid Heating Near Pressurized Fluid Lines

Flammable spray can be generated by heating near pressurized fluid lines, resulting in severe burns to yourself and bystanders. Do not heat by welding, soldering, or using a torch near pressurized fluid lines or other flammable materials. Pressurized lines can be accidentally cut when heat goes beyond the immediate flame area.



Flammable Spray

TS953 -UN-15MAY90

DX,TORCH -19-03MAR93-1/1

Illuminate Work Area Safely

Illuminate your work area adequately but safely. Use a portable safety light for working inside or under the machine. Make sure the bulb is enclosed by a wire cage. The hot filament of an accidentally broken bulb can ignite spilled fuel or oil.



Illuminate Work Area Safely

TS223 -UN-23AUG88

DX,LIGHT -19-04JUN90-1/1

Use Proper Lifting Equipment

Lifting heavy components incorrectly can cause severe injury or machine damage.

Follow recommended procedure for removal and installation of components in the manual.

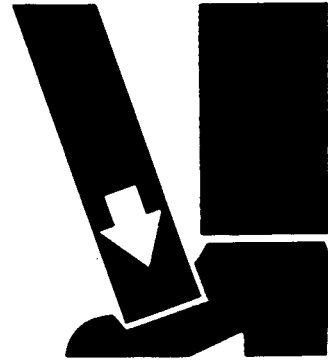

Use Proper Lifting Equipment

TSS226 -JUN-23AUG88

DX,LIFT -19-04JUN90-1/1

Construct Dealer-Made Tools Safely

Faulty or broken tools can result in serious injury. When constructing tools, use proper, quality materials and good workmanship.

Do not weld tools unless you have the proper equipment and experience to perform the job.

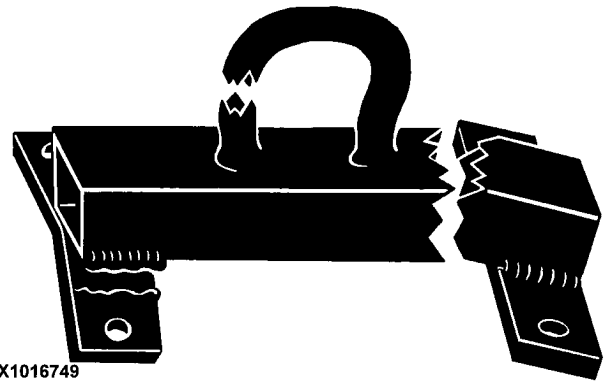

LX1016749

LX1016749 -JUN-01JUL97

Construct Dealer-Made Tools Safely

DPSG,OUO1004,899 -19-19MAY99-1/1

01
000
10

Practice Safe Maintenance

Understand service procedure before doing work. Keep area clean and dry.

Never lubricate, service, or adjust machine while it is moving. Keep hands, feet, and clothing from power-driven parts. Disengage all power and operate controls to relieve pressure. Lower equipment to the ground. Stop the engine. Remove the key. Allow machine to cool.

Securely support any machine elements that must be raised for service work.

Keep all parts in good condition and properly installed. Fix damage immediately. Replace worn or broken parts. Remove any buildup of grease, oil, or debris.

On self-propelled equipment, disconnect battery ground cable (-) before making adjustments on electrical systems or welding on machine.

On towed implements, disconnect wiring harnesses from tractor before servicing electrical system components or welding on machine.



Keep Area Clean

TS218 -UN-23AUG88

DX,SERV -19-17FEB99-1/1

Use Proper Tools

Use tools appropriate to the work. Makeshift tools and procedures can create safety hazards.

Use power tools only to loosen threaded parts and fasteners.

For loosening and tightening hardware, use the correct size tools. DO NOT use U.S. measurement tools on metric fasteners. Avoid bodily injury caused by slipping wrenches.

Use only service parts meeting John Deere specifications.



Use Proper Tools

TS779 -UN-08NOV89

DX,REPAIR -19-17FEB99-1/1