

HP1102 -UN-01JAN94



HP1102

*JOHN DEERE 132" BELT PICKUP WITH PLATFORM*

*(SPECIFICATIONS AND DESIGN SUBJECT TO CHANGE WITHOUT NOTICE)*

**DATE OF MANUFACTURE**

**BELT PICKUPS**

SIZE	DATE
110"	( - )
132"	( - )
154"	( - )

**PICKUP PLATFORMS**

SIZE	MODEL	DATE
12'	912	(1988-1993)
13-1/2'	914	(1988- )

# A3

PICKUP, BELT, THREE-ROLLER AND PICKUP PLATFORM - 900 SERIES

## SERIAL NUMBER PLATE

USE ALL NUMBERS, LETTERS, AND SPACES SHOWN ON THE SERIAL NUMBER PLATE IN WARRANTY CORRESPONDENCE.

PICKUP PLATFORM (625001- )

ON THESE PLATFORMS, THE SERIAL NUMBER PLATE IS LOCATED ON THE LEFT-HAND SIDE OF THE FRAME.

*EXAMPLE: H00912X625001  
PICKUP PLATFORM*

(FIRST LINE)            H0 - FACTORY (HARVESTER WORKS)  
                              0912 - PLATFORM MODEL  
                              X - CONFIGURATION/MODEL SUFFIX  
                              625001 - PLATFORM SEQUENCE NUMBER (SERIAL NUMBER)  
(SECOND LINE) PICKUP PLATFORM - PRODUCT TYPE

NOTE: BELT PICKUPS DO NOT HAVE SERIAL NUMBERS. CHANGES TO BELT PICKUPS ARE SHOWN BY YEARS.

### IMPORTANT

THIS PARTS CATALOG CONTAINS COMPLETE PARTS INFORMATION ON THE THREE-ROLLER BELT AND PICKUP PLATFORM. IT IS IMPORTANT THAT THE CORRECT SERIAL NUMBER BE USED WHEN ORDERING PARTS.

### SERIAL NUMBER LISTING INFORMATION

SERIAL NUMBER INFORMATION IS LISTED TO SHOW ON WHICH MACHINES EACH PART CAN BE USED, FOR EXAMPLE:

-            THE PART CAN BE USED ON ALL MACHINES.  
000000-        THE PART CAN BE USED ON ALL MACHINES BEGINNING WITH THE SERIAL NUMBER LISTED.  
-000000      THE PART CAN BE USED ON ALL MACHINES UP TO AND INCLUDING THE SERIAL NUMBER LISTED.  
000000-000000    THE PART CAN BE USED ON ALL MACHINES BETWEEN AND INCLUDING THE SERIAL NUMBERS LISTED.

WHEN XXXXXX'S ARE LISTED IN PLACE OF A SERIAL NUMBER, A SERIAL NUMBER CHANGE WAS MADE BUT THE EXACT SERIAL NUMBER WAS NOT AVAILABLE WHEN THE CATALOG WAS PRODUCED.

*COPYRIGHT (C) 2000. DEERE & COMPANY. MOLINE, ILLINOIS.  
ALL RIGHTS RESERVED*

## DIRECTION ARROW

ARROWS ARE USED WITH ILLUSTRATIONS TO INDICATE THE FRONT OF THE UNIT. "RIGHT-HAND" AND "LEFT-HAND" SIDES ARE DETERMINED BY FACING IN THE DIRECTION OF MACHINE FORWARD TRAVEL.

## BOX-ENCLOSED ILLUSTRATIONS

A KEY NUMBER, SHOWN IN THE PARTS LIST, IS ASSIGNED TO A BOX ENCLOSING ALL PARTS SOLD AS A SERVICE ASSEMBLY. A BOX NOT KEYED INCLUDES NON-CURRENT PARTS.

## KITS

KIT INFORMATION CAN BE FOUND IMMEDIATELY AFTER THE STORY IN WHICH IT IS USED. THE ILLUSTRATION IS REPEATED WITH ONLY THE KIT PARTS CALLED OUT AND ALL OTHER PARTS SHOWN IN PHANTOM.

## JDM REMANUFACTURED COMPONENTS

THE SERVICE PARTS LISTED IN THIS CATALOG ARE INTENDED FOR THE REPAIR OF ORIGINAL EQUIPMENT COMPONENTS. ALTHOUGH MOST SERVICE PARTS MAY BE USED TO REPAIR REMANUFACTURED COMPONENTS, THE REMANUFACTURED DESIGN MAY CHANGE PARTS SUFFICIENTLY SO THAT SERVICE PARTS ARE INADEQUATE OR NOT USABLE.

## BOLT AND CAP SCREW STRENGTH IDENTIFICATION

BOLTS AND CAP SCREWS REQUIRED TO HAVE HIGH-STRENGTH QUALITIES EQUIVALENT TO SAE GRADE 8 ARE IDENTIFIED THROUGHOUT THIS CATALOG BY THE DESCRIPTION HS SAE 8. ALL STANDARD BOLTS AND CAP SCREWS ARE SAE GRADE 5 OR LOWER. BOLTS AND CAP SCREWS REQUIRED TO HAVE HIGH-STRENGTH QUALITIES EQUIVALENT TO PROPERTY CLASS 10.9 ARE IDENTIFIED THROUGHOUT THIS CATALOG BY THE DESCRIPTION HS 10.9. ALL STANDARD BOLTS AND CAP SCREWS ARE PROPERTY CLASS 8.8 OR LOWER.

## SI UNITS OF MEASURE

METRIC DIMENSIONS ARE GIVEN, WHERE APPLICABLE, THROUGHOUT THIS PARTS CATALOG.

## TRADEMARKS

THROUGHOUT THIS PARTS CATALOG, YOU WILL FIND THE FOLLOWING DEERE & COMPANY TRADEMARKS:

DIAL-A-SPEED™  
DIAL-A-MATIC™  
HARVESTRAK™

POSI-TORQ™  
TORQ-GARD SUPREME®  
QUIK-TATCH™

## CHANGE INDICATOR LINE

CHANGES AFFECTING THE ORDERING OF PARTS ARE IDENTIFIED BY VERTICAL LINES MARKED IN THE L.H. MARGIN OF REVISED PARTS LISTING IMAGES. A LINE IS ALSO AT THE LEFT-HAND EDGE OF THE SAME PART NUMBER IN THE NUMERICAL INDEX TO SHOW THE LOCATION OF REVISED INFORMATION.

## FUNCTION CODE

(EXAMPLE - FC: 5000)

FUNCTION CODES ARE LOCATED ON EACH PAGE IN THE UPPER RIGHT-HAND CORNER. THE CODE LISTED IS A GROUPING CODE THAT CAN BE USED FOR WARRANTIES AND FOR DTAC TO IDENTIFY CERTAIN AREAS.

## COMPLETE GOODS LISTINGS

COMPLETE GOODS ARE IN BOLD FACE TYPE. ORDER SEPARATELY. DO NOT INCLUDE ON REPLACEMENT PARTS ORDER.

## SECTION INDEX

SECTION 05 - GENERAL INFORMATION

SECTION 10 - ROLLERS AND SUPPORTS

SECTION 15 - FRAME, STRIPPERS, DIVIDERS AND PLATES

SECTION 20 - HEADER HEIGHT CONTROL

SECTION 25 - AUGER AND DRIVE

SECTION 30 - HYDRAULICS

SECTION 35 - IDLERS, TIGHTENERS AND SHIELDS

SECTION 40 - BELTS, CHAINS, SHEAVES, SPROCKETS AND DECALS

SECTION 45 - NUMERICAL INDEX

# A6

PICKUP, BELT, THREE-ROLLER AND PICKUP PLATFORM - 900 SERIES

## ALPHABETICAL INDEX

GRID		PAGE	GRID		PAGE
	<b>A</b>			<b>C</b>	
A14	ARMS, FINGER HOLD-DOWN ( -655150) .....	10-3	A18	CENTER DRIVE ( -655150) .....	10-7
A15	ARMS, FINGER HOLD-DOWN (655150- ) .....	10-4	A19	CENTER DRIVE (655151- ) .....	10-8
C14	AUGER ADJUSTMENT BRACKETS ( -655150) .....	25-12	C16	CHAIN, CROSS AUGER DRIVE ( -635100) .....	25-14
C15	AUGER ADJUSTMENT BRACKETS (655151- ) .....	25-13	C18	CHAIN, CROSS AUGER DRIVE (635101-655150) .....	25-16
C12	AUGER AND SHAFT (655151- ) .....	25-10	C20	CHAIN, CROSS AUGER DRIVE (655151-665150) .....	25-18
C12	AUGER COVER (655151- ) .....	25-10	C22	CHAIN, CROSS AUGER DRIVE, 14' BPU (665151- ) .....	25-20
C24	AUGER DRIVE, CROSS (SIDEHILL) (PICKUP PLATFORM)(615251-640500) .....	25-22	E6	CHAIN, DRIVE, ON R.H. SIDE .....	40-1
D1	AUGER DRIVE, CROSS (SIDEHILL) (PICKUP PLATFORM)(645301-655300) .....	25-24	C16	CLUTCH, SLIP, CROSS AUGER DRIVE ( -635100) .....	25-14
D3	AUGER DRIVE, CROSS (SIDEHILL) (PICKUP PLATFORM)(655301- ) .....	25-26	C18	CLUTCH, SLIP, CROSS AUGER DRIVE (635101-655150) .....	25-16
C5	AUGER FLIGHT EXTENSIONS (655151- ) .....	25-2	C20	CLUTCH, SLIP, CROSS AUGER DRIVE (655151-665150) .....	25-18
C12	AUGER HUB (655151- ) .....	25-10	C22	CLUTCH, SLIP, CROSS AUGER DRIVE, 14' BPU (665151- ) .....	25-20
B17	AUTO BELT SPEED ( -655150) .....	20-8	D22	CONVERSION HOSES AND COUPLERS (600001-622500) .....	30-16
B19	AUTO BELT SPEED (655151- ) .....	20-10	D9	COUPLER, BRACKET, HYDRAULIC LINES ( -655150) .....	30-2
	<b>B</b>		D10	COUPLER, BRACKET, HYDRAULIC LINES (655151- ) .....	30-3
B7	BACK SHEETS ( -655150) .....	15-12	D14	COUPLER, HYDRAULIC MOTOR ( -655150) .....	30-8
B8	BACK SHEETS (655251- ) .....	15-13	D16	COUPLER, HYDRAULIC MOTOR (655151- ) .....	30-10
C12	BEARINGS, AUGER (655151- ) .....	25-10	C12	COVER, AUGER (655151- ) .....	25-10
A20	BEARINGS,CENTER AND IDLER ROLLERS DRIVE ( -655150) .....	10-10	C12	CRANK, AUGER (655151- ) .....	25-10
A21	BEARINGS,CENTER AND IDLER ROLLERS DRIVE (655151- ) .....	10-11	C8	CROSS AUGER AND SPROCKET ( -635100) .....	25-6
B17	BELT SPEED, AUTO ( -655150) .....	20-8	C10	CROSS AUGER AND SPROCKET (635101-655150) .....	25-8
B19	BELT SPEED, AUTO (655151- ) .....	20-10	C16	CROSS AUGER DRIVE ( -635100) .....	25-14
B2	BELTS AND FINGERS .....	15-7	C18	CROSS AUGER DRIVE (635101-655150) .....	25-16
B7	BOTTOM SHEET ( -655150) .....	15-12	C20	CROSS AUGER DRIVE (655151-665150) .....	25-18
B8	BOTTOM SHEET (655151- ) .....	15-13	C24	CROSS AUGER DRIVE (SIDEHILL) (PICKUP PLATFORM)(615251-640500) .....	25-22
D9	BRACKET, HYDRAULIC LINES ( -655150) .....	30-2	D3	CROSS AUGER DRIVE (SIDEHILL) (PICKUP PLATFORM)(655301- ) .....	25-26
D10	BRACKET, HYDRAULIC LINES (655151- ) .....	30-3	C22	CROSS AUGER DRIVE, 14' BPU (665151- ) .....	25-20
D14	BRACKET, HYDRAULIC MOTOR ( -655150) .....	30-8	D1	CROSS AUGER DRIVES (SIDEHILL) (PICKUP PLATFORM)(645301-655300) .....	25-24
D16	BRACKET, HYDRAULIC MOTOR (655151- ) .....	30-10		<b>D</b>	
C14	BRACKETS, ADJUSTMENT, AUGER ( -655150) .....	25-12	E7	DECALS .....	40-2
C15	BRACKETS, ADJUSTMENT, AUGER (655151- ) .....	25-13	B21	DIAL-A-MATIC BEARINGS ( -655150) .....	20-12
			B22	DIAL-A-MATIC BEARINGS (655151- ) .....	20-13
			B21	DIAL-A-MATIC BRACKETS ( -655150) .....	20-12
			B22	DIAL-A-MATIC BRACKETS (655151- ) .....	20-13

# A7

PICKUP, BELT, THREE-ROLLER AND PICKUP PLATFORM - 900 SERIES

## ALPHABETICAL INDEX - CONTINUED

<i>GRID</i>		<i>PAGE</i>	<i>GRID</i>		<i>PAGE</i>
B11	DIAL-A-MATIC SENSING BOX ( -655150) .....	20 - 1	B1	FLAP, STRIPPER ( -655151) .....	15 - 5
B12	DIAL-A-MATIC SENSING BOX (655151- ) .....	20 - 2	A24	FLAP, STRIPPER (655151- ) .....	15 - 3
B21	DIAL-A-MATIC SHAFT ( -655150) .....	20 - 12	C4	FLIGHT EXTENSIONS ( -655300) .....	25 - 1
B22	DIAL-A-MATIC SHAFT (655151- ) .....	20 - 13	C5	FLIGHT, AUGER, EXTENSIONS (655151- ) .....	25 - 2
B13	DIAL-A-MATIC WIRING HARNESS ( -655150) .....	20 - 4	C6	FLIGHT, WINDROW SPREADER ( -655150) .....	25 - 3
B15	DIAL-A-MATIC WIRING HARNESS (655151- ) .....	20 - 6	C7	FLIGHT, WINDROW SPREADER (655151- ) .....	25 - 4
B13	DIAL-A-MATIC, HEADER HEIGHT CONTROL ( -655150) .....	20 - 4	A18	FRAME, IDLER ROLLERS ( -655150) .....	10 - 7
B15	DIAL-A-MATIC, HEADER HEIGHT CONTROL (655151- ) .....	20 - 6	A19	FRAME, IDLER ROLLERS (655151- ) .....	10 - 8
B13	DIAL-A-SPEED CONTROL ( -655150) .....	20 - 4	B3	FRAME, MAIN AND RUNNERS ( -655150) .....	15 - 8
B15	DIAL-A-SPEED CONTROL (655151- ) .....	20 - 6	B5	FRAME, MAIN AND RUNNERS (655151- ) .....	15 - 10
E6	DRIVE CHAIN ON RIGHT-HAND SIDE .....	40 - 1	<b>G</b>		
D13	DRIVE MOTOR, HYDRAULIC ( -625900) .....	30 - 6	A12	GAUGE WHEELS ( -655150) .....	10 - 1
D6	DRIVE SHAFT, HEADER-SIDEHILL (615251-640500) .....	25 - 29	A13	GAUGE WHEELS (655151- ) .....	10 - 2
D5	DRIVE SHAFT, MAIN (645251- ) .....	25 - 28	B7	GRAIN SLIDE ( -655150) .....	15 - 12
A18	DRIVE, CENTER ( -655150) .....	10 - 7	B8	GRAIN SLIDE (655151- ) .....	15 - 13
A19	DRIVE, CENTER (655151- ) .....	10 - 8	C6	GUSSETT, WINDROW SPREADER ( -655150) .....	25 - 3
C16	DRIVE, CROSS AUGER ( -635100) .....	25 - 14	C7	GUSSETT, WINDROW SPREADER (655151- ) .....	25 - 4
C18	DRIVE, CROSS AUGER (635101-655150) .....	25 - 16	<b>H</b>		
C20	DRIVE, CROSS AUGER (655151-665150) .....	25 - 18	D6	HEADER DRIVE SHAFT-SIDEHILL (615251-640500) .....	25 - 29
C24	DRIVE, CROSS AUGER (SIDEHILL) (PICKUP PLATFORM)(615251-640500) .....	25 - 22	B21	HEADER HEIGHT CONTROL BEARING ( -655150) .....	20 - 12
D1	DRIVE, CROSS AUGER (SIDEHILL) (PICKUP PLATFORM)(645301-655300) .....	25 - 24	B22	HEADER HEIGHT CONTROL BEARING (655151- ) .....	20 - 13
D3	DRIVE, CROSS AUGER (SIDEHILL) (PICKUP PLATFORM)(655301- ) .....	25 - 26	B21	HEADER HEIGHT CONTROL BRACKETS ( -655150) .....	20 - 12
C22	DRIVE, CROSS AUGER, 14' BPU (665151- ) .....	25 - 20	B22	HEADER HEIGHT CONTROL BRACKETS (655151- ) .....	20 - 13
<b>E</b>			B21	HEADER HEIGHT CONTROL SHAFT ( -655150) .....	20 - 12
C4	EXTENSIONS, FLIGHT ( -655300) .....	25 - 1	B22	HEADER HEIGHT CONTROL SHAFT (655151- ) .....	20 - 13
C5	EXTENSIONS, FLIGHT, AUGER (655151- ) .....	25 - 2	B13	HEADER HEIGHT CONTROL WIRING HARNESS ( -655150) .....	20 - 4
<b>F</b>			B15	HEADER HEIGHT CONTROL WIRING HARNESS (655151- ) .....	20 - 6
C12	FINGERS, AUGER (655151- ) .....	25 - 10	A14	HOLD-DOWN FINGERS ( -655150) .....	10 - 3
A14	FINGERS, HOLD-DOWN ( -655150) .....	10 - 3	A15	HOLD-DOWN FINGERS (655151- ) .....	10 - 4
A15	FINGERS, HOLD-DOWN (655150- ) .....	10 - 4	D22	HOSE AND COUPLER CONVERSION (600001-622500) .....	30 - 16
A23	FLAP, STRIPPER ( -655150) .....	15 - 2	D11	HOSES, HYDRAULIC ( -655150) .....	30 - 4
A25	FLAP, STRIPPER ( -655150) .....	15 - 4			

# A8

PICKUP, BELT, THREE-ROLLER AND PICKUP PLATFORM - 900 SERIES

## ALPHABETICAL INDEX - CONTINUED

GRID		PAGE	GRID		PAGE
D12	HOSES, HYDRAULIC (655151- ) .....	30-5		M	
A20	HOUSINGS, BEARINGS, IDLER DRIVE ROLLER ( -655150) .....	10-10	D5	MAIN DRIVE SHAFT (645251- ) .....	25-28
A21	HOUSINGS, BEARINGS, IDLER DRIVE ROLLER (655151- ) .....	10-11	B3	MAIN FRAME AND RUNNERS ( -655150) .....	15-8
C12	HUB, AUGER (655151- ) .....	25-10	B5	MAIN FRAME AND RUNNERS (655151- ) .....	15-10
D13	HYDRAULIC DRIVE MOTOR ( -625900) .....	30-6	B23	MARKER LIGHTS ( -655150) .....	20-14
D9	HYDRAULIC LINES AND BRACKET ( -655150) .....	30-2	B24	MARKER LIGHTS (655151- ) .....	20-15
D10	HYDRAULIC LINES AND BRACKET (655151- ) .....	30-3	D7	METRIC KEY STOCK KIT .....	25-30
D11	HYDRAULIC LINES AND HOSES ( -655150) .....	30-4	D14	MOTOR, COUPLER ( -655150) .....	30-8
D12	HYDRAULIC LINES AND HOSES (655151- ) .....	30-5	D16	MOTOR, COUPLER (655151- ) .....	30-10
D14	HYDRAULIC MOTOR COUPLER ( -655150) .....	30-8	D13	MOTOR, DRIVE, HYDRAULIC ( -625900) .....	30-6
D16	HYDRAULIC MOTOR COUPLER (655151- ) .....	30-10	D18	MOTOR, HYD., HYDROSTATIC DRIVE REEL ( -655290) (ROSS) .....	30-12
D14	HYDRAULIC MOTOR MOUNTING BRACKET ( -655150) .....	30-8	D14	MOTOR, MOUNTING BRACKET ( -655150) .....	30-8
D16	HYDRAULIC MOTOR MOUNTING BRACKET (655151- ) .....	30-10	D16	MOTOR, MOUNTING BRACKET (655151- ) .....	30-10
D18	HYDRAULIC MOTOR, HYDROSTATIC DRIVE REEL ( -655290) (ROSS) .....	30-12	D20	MOTOR, REEL (EATON) (655291- ) .....	30-14
D18	HYDROSTATIC DRIVE REEL HYDRAULIC MOTOR ( -655290) .....	30-12	B2	MOUNTING SUPPORTS .....	15-7
	I			R	
A18	IDLER ROLLERS ( -655150) .....	10-7	D18	REEL MOTOR ( -655290) (ROSS) .....	30-12
A19	IDLER ROLLERS (655151- ) .....	10-8	D20	REEL MOTOR (EATON) (655291- ) .....	30-14
	K		A14	RETAINER, HOLD-DOWN FINGERS ( -655150) .....	10-3
D7	KEY STOCK, METRIC KIT .....	25-30	A15	RETAINER, HOLD-DOWN FINGERS (655150- ) .....	10-4
D7	KIT, METRIC KEY STOCK .....	25-30	A18	ROLLERS, IDLER ( -655150) .....	10-7
	L		A19	ROLLERS, IDLER (655151- ) .....	10-8
B23	LIGHTS, MARKER ( -655150) .....	20-14	B3	RUNNERS AND MAIN FRAME ( -655150) .....	15-8
B24	LIGHTS, MARKER (655151- ) .....	20-15	B5	RUNNERS AND MAIN FRAME (655151- ) .....	15-10
B25	LIGHTS, STUBBLE ( -655150) .....	20-16		S	
C1	LIGHTS, STUBBLE (655151- ) .....	20-17	B11	SENSING BOX MOUNTING, DIAL-A-MATIC ( -655150) .....	20-1
D9	LINES, HYDRAULIC ( -655150) .....	30-2	B12	SENSING BOX MOUNTING, DIAL-A-MATIC (655151- ) .....	20-2
D11	LINES, HYDRAULIC ( -655150) .....	30-4	B11	SENSING BOX, DIAL-A-MATIC ( -655150) .....	20-1
D10	LINES, HYDRAULIC (655151- ) .....	30-3	B12	SENSING BOX, DIAL-A-MATIC (655151- ) .....	20-2
D12	LINES, HYDRAULIC (655151- ) .....	30-5	C12	SHAFT AND AUGER (655151- ) .....	25-10
			C16	SHAFT, CROSS AUGER DRIVE ( -635100) .....	25-14
			C18	SHAFT, CROSS AUGER DRIVE (635101-655150) .....	25-16

# A9

PICKUP, BELT, THREE-ROLLER AND PICKUP PLATFORM - 900 SERIES

## ALPHABETICAL INDEX - CONTINUED

GRID	PAGE	GRID	PAGE
C20	SHAFT, CROSS AUGER DRIVE (655151-665150) .....	A24	STRIPPER (655151- ) .....
	25 - 18		15 - 3
C22	SHAFT, CROSS AUGER DRIVE, 14' BPU (665151- ) .....	A23	STRIPPER FLAP ( -655150) .....
	25 - 20		15 - 2
D6	SHAFT, HEADER DRIVE-SIDEHILL (615251-640500) .....	A25	STRIPPER FLAP ( -655150) .....
	25 - 29		15 - 4
D5	SHAFT, MAIN DRIVE (645251- ) .....	B1	STRIPPER FLAP ( -655151) .....
	25 - 28		15 - 5
B7	SHEET, BOTTOM ( -655150) .....	A24	STRIPPER FLAP (655151- ) .....
	15 - 12		15 - 3
B8	SHEET, BOTTOM (655151- ) .....	B25	STUBBLE LIGHTS ( -655150) .....
	15 - 13		20 - 16
B7	SHEETS, BACK ( -655150) .....	C1	STUBBLE LIGHTS (655151- ) .....
	15 - 12		20 - 17
B8	SHEETS, BACK (655151- ) .....	A12	SUPPORT, YOKE ( -655150) .....
	15 - 13		10 - 1
E2	SHIELD ( -635100) .....	A13	SUPPORT, YOKE (655151- ) .....
	35 - 2		10 - 2
E3	SHIELD (635101-655150) .....		
	35 - 3		T
E4	SHIELD (655151- ) .....		
	35 - 4		
C16	SHIELD, CROSS AUGER DRIVE ( -635100) .....	E6	TIGHTENERS AND SPROCKETS ON R.H. SIDE .....
	25 - 14		40 - 1
C18	SHIELD, CROSS AUGER DRIVE (635101-655150) .....		
	25 - 16		W
C20	SHIELD, CROSS AUGER DRIVE (655151-665150) .....		
	25 - 18		
C22	SHIELD, CROSS AUGER DRIVE, 14' BPU (665151- ) .....	D6	WALTERSCHIED HEADER DRIVE SHAFT, S.H. (615251-640500) .....
	25 - 20		25 - 29
A16	SHIELDS, PICKUP ( -655150) .....	A12	WHEEL YOKE ( -655150) .....
	10 - 5		10 - 1
A17	SHIELDS, PICKUP (655151- ) .....	A13	WHEEL YOKE (655151- ) .....
	10 - 6		10 - 2
D6	SIDEHILL-HEADER DRIVE SHAFT (615251-640500) .....	A12	WHEELS, GAUGE ( -655150) .....
	25 - 29		10 - 1
B17	SPEED, AUTO BELT ( -655150) .....	A13	WHEELS, GAUGE (655151- ) .....
	20 - 8		10 - 2
B19	SPEED, AUTO BELT (655151- ) .....	C6	WINDROW SPREADER FLIGHT ( -655150) .....
	20 - 10		25 - 3
C8	SPROCKET AND CROSS AUGER ( -635100) .....	C7	WINDROW SPREADER FLIGHT (655151- ) .....
	25 - 6		25 - 4
C10	SPROCKET AND CROSS AUGER (635101-655150) .....	B13	WIRING HARNESS, HEADER HEIGHT CONTROL ( -655150) .....
	25 - 8		20 - 4
E6	SPROCKETS AND TIGHTENERS ON R.H. SIDE .....	B15	WIRING HARNESS, HEADER HEIGHT CONTROL (655151- ) .....
	40 - 1		20 - 6
C16	SPROCKETS, CROSS AUGER DRIVE ( -635100) .....		
	25 - 14		Y
C18	SPROCKETS, CROSS AUGER DRIVE (635101-655150) .....		
	25 - 16		
C20	SPROCKETS, CROSS AUGER DRIVE (655151-665150) .....	A12	YOKE SUPPORT ( -655150) .....
	25 - 18		10 - 1
C22	SPROCKETS, CROSS AUGER DRIVE, 14' BPU (665151- ) .....	A13	YOKE SUPPORT (655151- ) .....
	25 - 20		10 - 2
A20	SPROCKETS,CENTER AND IDLER ROLLERS DRIVE ( -655150) .....		
	10 - 10		
A21	SPROCKETS,CENTER AND IDLER ROLLERS DRIVE (655151- ) .....		
	10 - 11		
A23	STRIPPER ( -655150) .....		
	15 - 2		
A25	STRIPPER ( -655150) .....		
	15 - 4		
B7	STRIPPER ( -655150) .....		
	15 - 12		
B1	STRIPPER ( -655151) .....		
	15 - 5		
B8	STRIPPER (655151- ) .....		
	15 - 13		



# A12

## ROLLERS AND SUPPORTS

GAUGE WHEELS  
(R.H. ILLUSTRATED)  
(-655105)  
HP5557 -UN-01JAN94

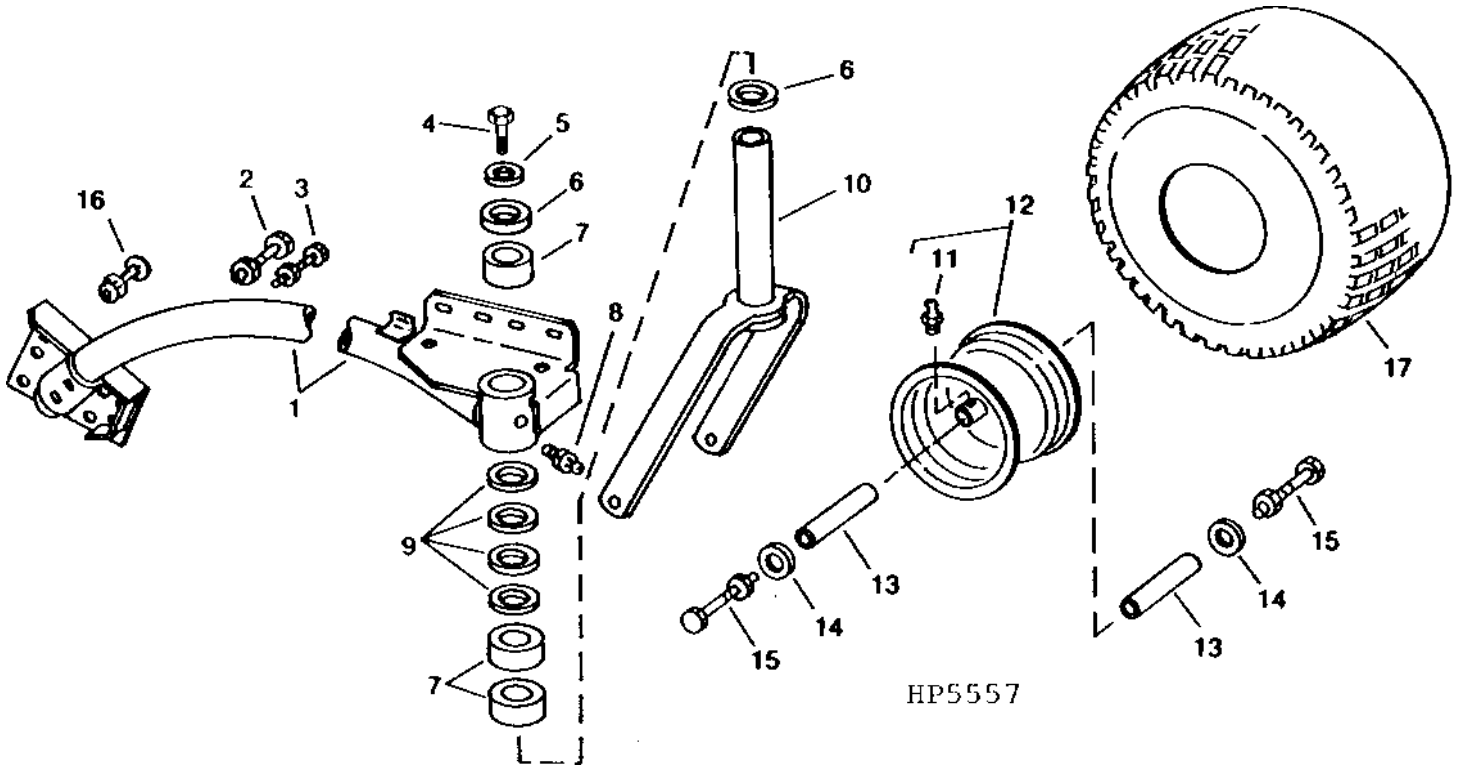

KEY	PART NO.	PART NAME	QTY	SERIAL NO.	REMARKS
1	AH116955	ARM	1	-640100	R.H.
	AH132562	SUPPORT	1	640101-	R.H.
	AH116956	ARM	1	-640100	L.H.
	AH132563	SUPPORT	1	640101-	L.H.
2	03H1731	BOLT	8		1/2" X 1-1/2"
	E54809	LOCK NUT	8		12.700 MM (1/2")
3	03H1709	BOLT	4		5/16" X 1"
	N10213	LOCK NUT	4		7.925 MM (5/16")
4	19H1792	CAP SCREW	2	-640100	1/2" X 1"
	19M7788	SCREW	2	640101-	M12 X 25
	12H301	LOCK WASHER	2	-640100	1/2"
5	24H1347	WASHER	2		17/32" X 2" X 0.194"
6	24H1520	WASHER	4		1-15/32" X 2" X 0.105"
7	H111742	RING	6		
8	JD7797	LUBRICATION FITTING	2		STRAIGHT, 1/4"
9	E32172	WASHER	8		38.100 X 57.150 X 6.350 MM (1-1/2" X 2-1/4" X 1/4")
10	AH102883	YOKE	2	-640100	
	AH133711	YOKE	2	640101-	
11	JD7829	LUBRICATION FITTING	2		STRAIGHT, 5/16"
12	AG903E	WHEEL	2	-640100	(USE 20 X 10.00 - 8 (4 PLY) TIRES)
	AH133712	WHEEL	2	640101-	(USE 20 X 10.00 - 8 (4 PLY) TIRES)
13	E16421	SPACER	2	-640100	16.662 X 25.273 X 129.388 MM (21/32" X 0.995" X 5-3/32")
	H139004	PIN	2	640101-	
14	G6891E	CAP	4		
15	08H3439	CAP SCREW	2	-640100	5/8" X 7-1/4"
	19M7843	SCREW	4	640101-	M16 X 35
	12H294	LOCK WASHER	2	-640100	5/8"
	14H760	NUT	2	-640100	5/8"
16	03H1659	BOLT	1		1/2" X 1"
	E54809	LOCK NUT	1		12.700 MM (1/2")
17	.....	TIRE	2		

**GAUGE WHEELS**  
 (R.H. ILLUSTRATED)  
 (655151- )  
 HP8391 -UN-24MAR99

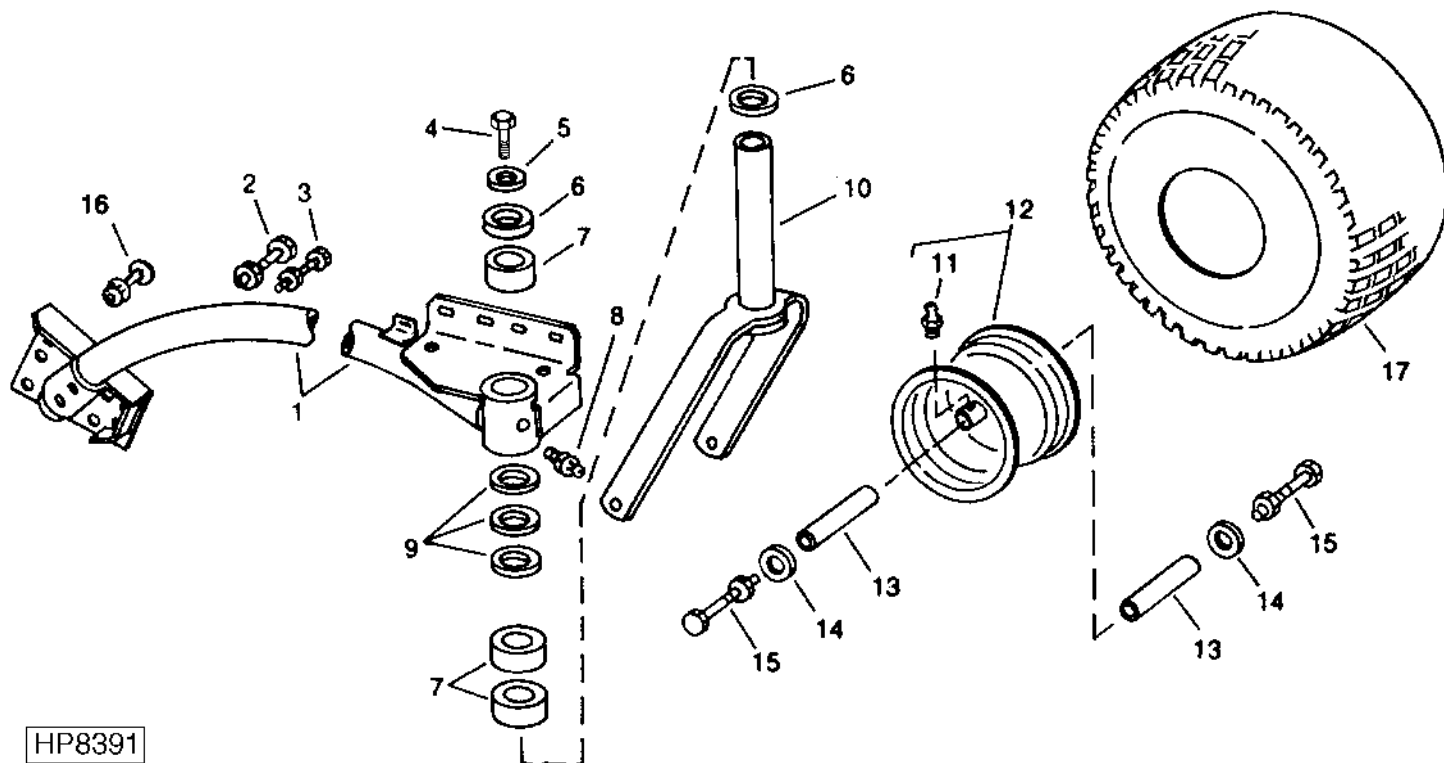

HP8391

KEY	PART NO.	PART NAME	QTY	SERIAL NO.	REMARKS
1	AH132562	SUPPORT	1	R.H.	
	AH132563	SUPPORT	1	L.H.	
2	03M7200	BOLT	8	M12 X 40	
	14M7299	FLANGE NUT	8	M12	
3	03M7185	BOLT	4	M8 X 25	
	14M7298	FLANGE NUT	4	M8	
4	19M7788	SCREW	2	M12 X 25	
5	24H1347	WASHER	2	17/32" X 2" X 0.194"	
6	24H1520	WASHER	4	1-15/32" X 2" X 0.105"	
7	H111742	RING	6		
8	JD7797	LUBRICATION FITTING	2	STRAIGHT, 1/4"	
9	E32172	WASHER	6		
10	AH133711	YOKE	2		
11	JD7829	LUBRICATION FITTING	2	STRAIGHT, 5/16"	
12	AH133712	WHEEL	2	(USE 20 X 10.00 - 8 (4 PLY) TIRES)	
13	H139004	PIN	2		
14	G6891E	CAP	4		
15	19M7843	SCREW	2	M16 X 35	
16	03M7197	BOLT	1	M12 X 25	
	14M7299	FLANGE NUT	1	M12	
17	.....	TIRE	2	(4 PLY TIRE)	
	.....	TIRE	2	(6 PLY TIRE) (CIS COUNTRIES ONLY)	

BH79209 (COMPLETE GOODS) BELT PICKUP FRAME 110"