



**Parts  
Catalog**

**John Deere  
JD450 Crawler Loader**

**PC-927**





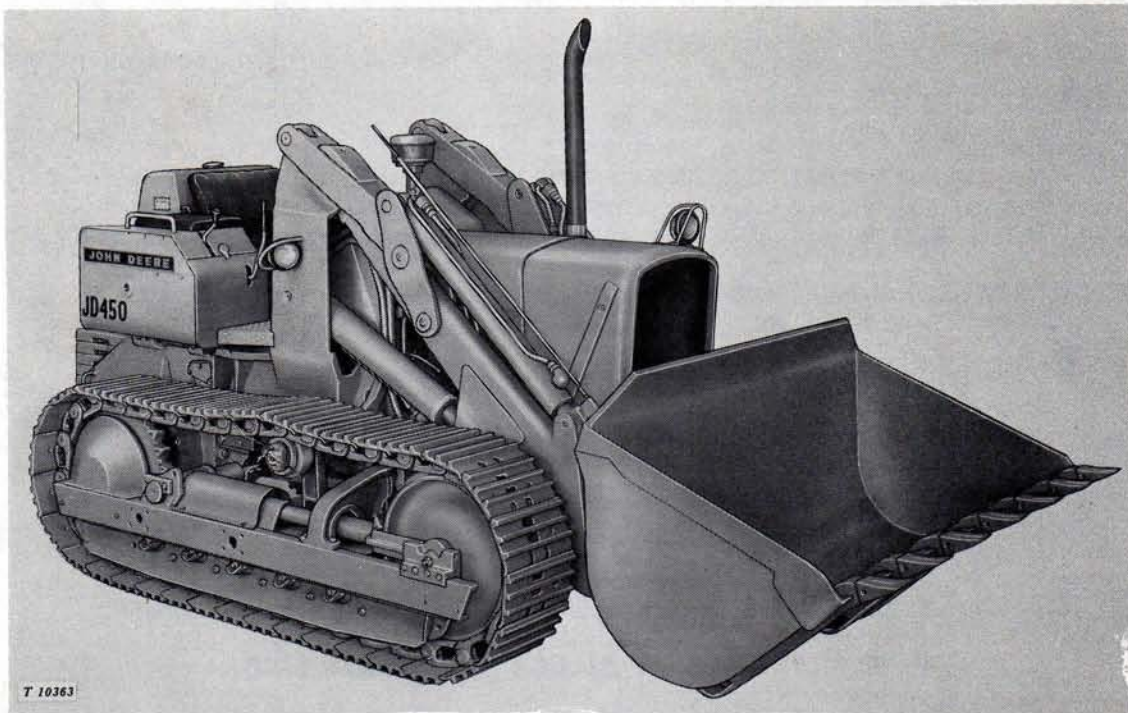

*John Deere JD450 Crawler Loader  
Manufactured (1965-1970)*

*(Specifications and design subject to change without notice)*

**TO THE CUSTOMER**

The part numbers in this catalog were correct at the time your machine was manufactured. It is our policy to constantly improve our machines and, therefore, part numbers may change. When ordering parts, verify part numbers through your dealer's catalog which is up to date.

NOTE: Serial number plates on JD450 Crawler Loaders bear the number 7450 as a basic prefix portion of the serial number. This is not a machine model number and should not be used to identify the Loader.

NOTE: For JD450 Crawler Tractor Parts Requirements, Refer To PC-922



## AN EXPLANATION OF SERIAL NUMBER INFORMATION

Serial number information is listed parenthetically to show on which machines each part can be used. These listings are explained by the following examples.

- (            -            ) The part can be used on all machines.
- (000000-            ) The part can be used on all machines beginning with the serial number listed.
- (            -000000) The part can be used on all machines up to and including serial number listed.
- (000000-000000) The part can be used on all machines between and including the serial numbers listed.

Where XXXXX's are listed in place of a serial number it indicates a serial number change was made but the exact serial number had not been established when the catalog went to press.

## BOLT AND CAP SCREW STRENGTH IDENTIFICATION

Bolts and cap screws required to have high-strength qualities equivalent to SAE Grade 8 are identified throughout this catalog by the description HS, SAE 8. Unless identified by this description all standard bolts and cap screws are SAE Grade 5 or lower.

## COMPLETE GOODS LISTINGS

Complete goods are listed in bold face type. Order separately. Do not include on replacement part order.

## AN EXPLANATION OF CHANGE INDICATOR LINE

New and revised information is identified by vertical lines marked in the left-hand margin of revised pages. These lines indicate changes affecting the ordering of parts.

## SI UNITS OF MEASURE

Metric equivalents have been included, where applicable, throughout this parts catalog.

## AN EXPLANATION OF BOX ENCLOSED ILLUSTRATIONS AND ILLUSTRATIONS WITH AN ARROW

Throughout this catalog a key number, shown in the parts list, is assigned to the box enclosing all parts sold as a service assembly. Arrows are used with illustrations to indicate the front of the unit.

## SECTIONAL INDEX

- Section 5 - General Information
- Section 10 - Buckets, Boom, Main Frame and Reservoir
- Section 15 - Hydraulics and Decals
- Section 20 - 7710 and 7711 Blade, Boom, Counterweights and Decals
- Section 25 - Drott 4-in-1 Bucket Hydraulics
- Section 30 - Numerical Index

ALPHABETICAL INDEX

GRID		PAGE	GRID		PAGE
<b>B</b>					
D3	BOOM .....	10-2	E18	OIL LINES AND FITTINGS, DROTT BUCKET .....	25-6
E11	BRACKET, MOUNTING, REAR .....	20-6	D25	OIL LINES AND FITTINGS, PRESSURE .....	15-16
E6	BRACKETS, RAKE .....	20-1	D25	OIL LINES AND FITTINGS, RETURN CIRCUIT .....	15-16
E12	BUCKET, DROTT, 4-IN-1 .....	20-7	<b>P</b>		
D2	BUCKET, LIGHT MATERIAL, 1-3/4 YARD .....	10-1	D12	PLATE, NAME .....	15-2
D2	BUCKET, 1-1/8 YARD .....	10-1	D22	PUMP .....	15-12
E6	BULLDOZER BLADE, 7710 .....	20-1	D23	PUMP .....	15-13
E8	BULLDOZER BLADE, 7711 .....	20-3	D24	PUMP .....	15-14
E7	BULLDOZER BOOM, 7711 .....	20-2	<b>R</b>		
<b>C</b>					
D11	CAP, RESERVOIR .....	15-1	D8	RESERVOIR .....	10-8
E9	COUNTERWEIGHTS AND BRACKETS .....	20-4	D9	RESERVOIR DOOR AND LID .....	10-9
E10	COUNTERWEIGHTS AND BRACKETS .....	20-5	<b>S</b>		
D17	CYLINDER, BOOM .....	15-7	D20	SEAL ISOLATOR .....	15-10
D18	CYLINDER, BUCKET .....	15-8	E3	SINGLE CLAMP LUMBER FORK HYDRAULICS .....	15-19
E14	CYLINDER, CLAM, DROTT BUCKET .....	25-2	D20	STRIP, SEALING .....	15-10
E15	CYLINDER, CLAM, DROTT BUCKET .....	25-3	<b>T</b>		
E16	CYLINDER, CLAM, DROTT BUCKET .....	25-4	D2	TEETH, BUCKET .....	10-1
<b>D</b>					
D12	DECALCOMANIAS .....	15-2	<b>V</b>		
E15	DECALCOMANIAS .....	25-3	D14	VALVE CONTROL .....	15-4
E4	DUAL CLAMP LUMBER FORK HYDRAULICS .....	15-20	D15	VALVE CONTROL .....	15-5
<b>E</b>					
D2	EDGE, CUTTING, BUCKET .....	10-1	D13	VALVE, CONTROL .....	15-3
<b>F</b>					
D11	FILTER, MICRONIC .....	15-1	D13	VALVE, RELIEF, CIRCUIT .....	15-3
D12	FILTER, WIRE MESH .....	15-2	D14	VALVE, RELIEF, CIRCUIT .....	15-4
D4	FRAME, MAIN .....	10-3	E17	VALVE, RELIEF, DROTT BUCKET .....	25-5
<b>I</b>					
D21	INDICATOR, BUCKET LEVEL .....	15-11	D13	VALVE, RELIEF, SYSTEM .....	15-3
E11	INDICATOR, DROTT BUCKET .....	20-6	D14	VALVE, RELIEF, SYSTEM .....	15-4
D20	ISOLATOR, SEAL .....	15-10	<b>L</b>		
<b>L</b>					
D3	LINKAGE, BOOM .....	10-2	D3	LINKAGE, BOOM .....	10-2
D16	LINKAGE, CONTROL VALVE .....	15-6	D16	LINKAGE, CONTROL VALVE .....	15-6
D6	LUMBER CLAMP CYLINDER ASSEMBLY .....	10-5	D6	LUMBER CLAMP CYLINDER ASSEMBLY .....	10-5
D19	LUMBER CLAMP CYLINDER ASSEMBLY .....	15-9	D19	LUMBER CLAMP CYLINDER ASSEMBLY .....	15-9
D6	LUMBER FORK CLAMP AND CYLINDER .....	10-5	D6	LUMBER FORK CLAMP AND CYLINDER .....	10-5
D5	LUMBER FORK FRAME AND LOAD ARM SHAFT .....	10-4	D5	LUMBER FORK FRAME AND LOAD ARM SHAFT .....	10-4
D7	LUMBER FORK LOAD ARM AND STANDARD .....	10-6	D7	LUMBER FORK LOAD ARM AND STANDARD .....	10-6
<b>O</b>					
E19	OIL LINES AND FITTINGS .....	25-7	<b>O</b>		
E1	OIL LINES AND FITTINGS, BOOM CIRCUIT .....	15-17	E19	OIL LINES AND FITTINGS .....	25-7
E2	OIL LINES AND FITTINGS, BUCKET CIRCUIT .....	15-18	E1	OIL LINES AND FITTINGS, BOOM CIRCUIT .....	15-17
			E2	OIL LINES AND FITTINGS, BUCKET CIRCUIT .....	15-18



BUCKETS

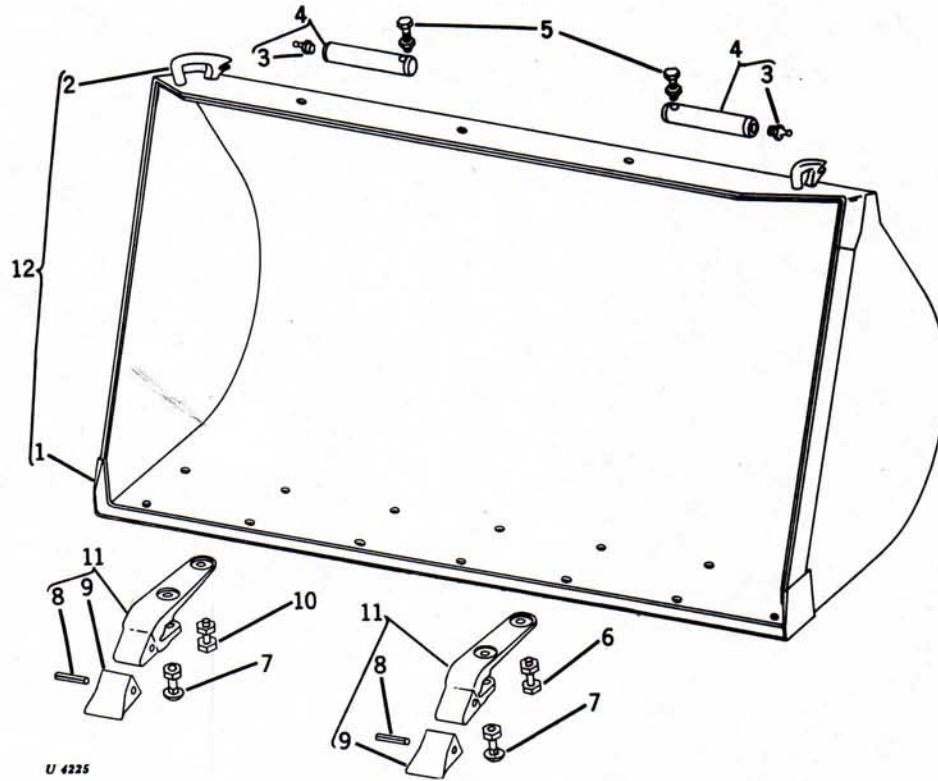

KEY	PART NO.	YEAR OR SERIAL NO.	DESCRIPTION
1	U 16966	( - )	EDGE, CUTTING (1-1/8-CU. YARD (0.9 M3) BUCKET)
	U 40116	( - )	EDGE, CUTTING (1-3/4-CU. YARD (1.3 M3) LIGHT MATERIALS BUCKET)
2	U 11773	( - )	HOOK, RING (2 USED)
3	JD 7759	( - )	FITTING, GREASE, 1/8" (4 USED)
4	AU 14012	( - )	PIN (4 USED)
5	19H 1868	( - )	SCREW, CAP, 1/2" X 3-3/4" (4 USED)
	BP 12214	( - )	NUT, STOP (4 USED) (SUB. FOR U12622)
6	19H 1734	( - )	SCREW, CAP, 5/8" X 2" (2 USED)
	U 14555	( - )	NUT, LOCK, 5/8" (2 USED)
7	10H 1043	( - )	BOLT, PLOW, NO. 3, 5/8" X 3" (7 USED)
	U 14555	( - )	NUT, LOCK, 5/8" (7 USED)
8	T 25101	( - )	PIN, GROOVE (7 USED)
9	U 16086	( - )	TIP, TOOTH (7 USED)
10	19H 1833	( - )	SCREW, CAP, 5/8" X 1-1/4" (5 USED)
	U 14555	( - )	NUT, LOCK, 5/8" (5 USED)
11	AU 13811	( - )	TOOTH, BUCKET (7 USED)
12	BU 10772	( - )	BUCKET, 1-1/8-CU. YARD (0.9 M3) (INCLUDES PINS AND TEETH)
	BU 40017	( - )	BUCKET, 1-3/4-CU. YARD (1.3 M3 LIGHT MATERIALS)