

Open front screen

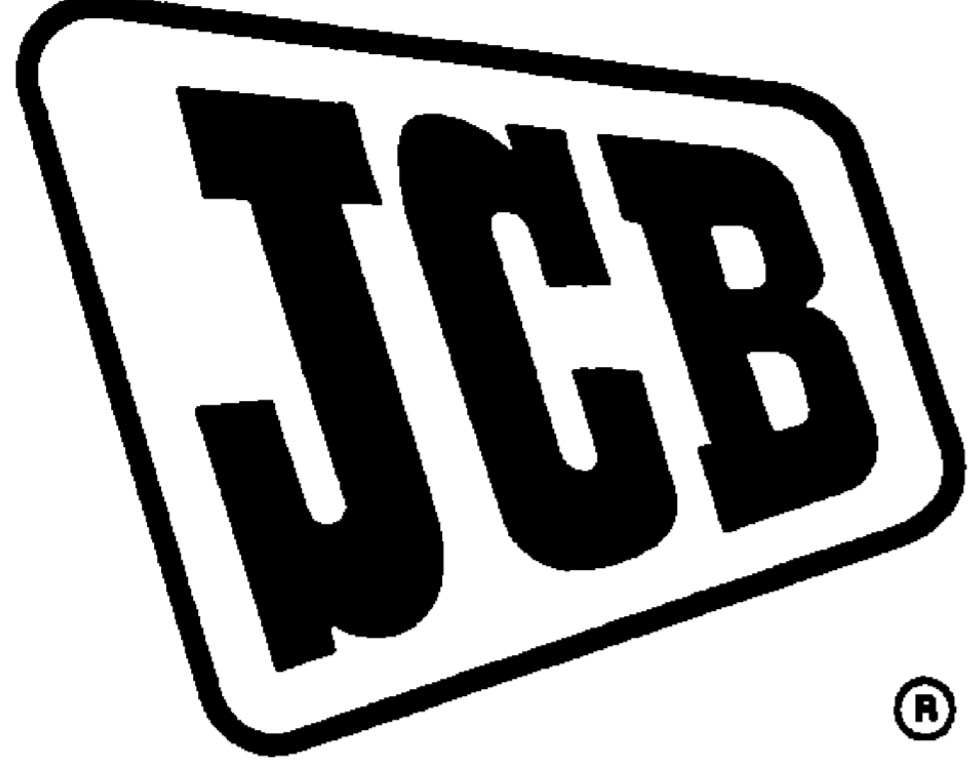

Service Manual

FASTRAC
125 135 145
150 155 185

PUBLISHED BY THE
TECHNICAL PUBLICATIONS DEPARTMENT
OF JCB SERVICE; ©
ROCESTER, STAFFORDSHIRE, ST14 5LS
ENGLAND
Tel. ROCESTER (01889) 590312
PRINTED IN ENGLAND

Publication No. 9803/8000

General Information

1

Care & Safety

2

Routine Maintenance

3

Optional equipment

A

Body & Framework

B

Electrics

C

Controls

D

Hydraulics

E

Transmission

F

Brakes

G

Steering

H

Suspension

S

Engine

T

Contents	Page No.
Location of Serial Numbers	1 - 1
Typical Vehicle Identification Number (VIN)	1 - 1
Typical Engine Identification Number	1 - 1
Unit Identification	1 - 1
Torque Settings	2 - 1
Hose and Pipe Connections	2 - 2
Service Tools Numerical List	3 - 1
Sealing and Retaining Compounds	3 - 2
· Service Tools	
Body and Framework	3 - 3
Electrics	3 - 6
Hydraulics	4 - 1
Transmission	5 - 2
Brakes	5 - 3
Steering	5 - 3
Suspension	5 - 4
Engine	5 - 4
Moving a Disabled Machine	6 - 1
Preparation for Towing	6 - 1
Transporting the Machine	6 - 2

Serial Number Plate

Each machine has a serial number plate located at either X or Y. Various designs of serial number plate have been used but in each case the Vehicle Identification Number (VIN), and the serial numbers of the engine and transmission are stamped on the plate.

Typical Early Style Vehicle Identification No. (VIN)

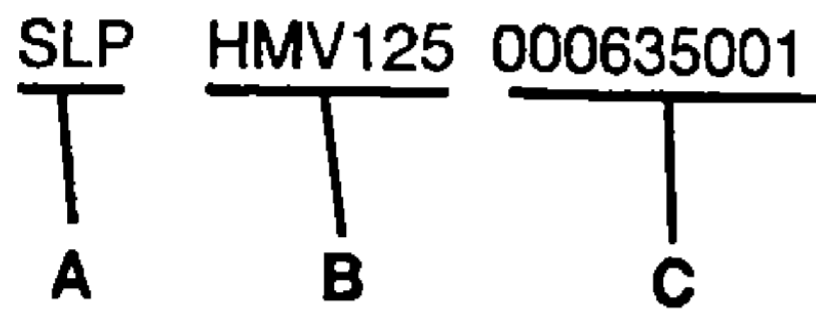

- A = Manufacturing Code
- B = Machine Model
- C = Serial Number

Typical Later Style Vehicle Identification No. (VIN)

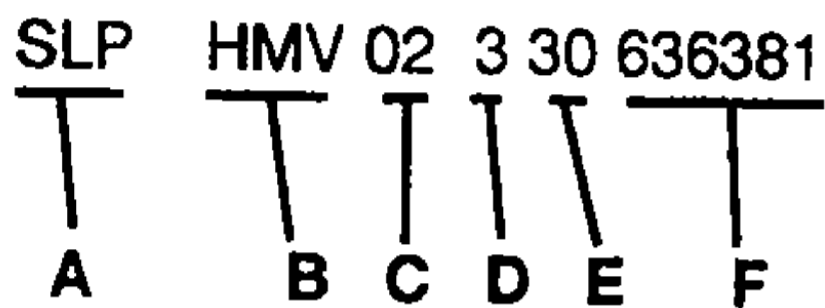

- A = Manufacturing Code
- B = Machine Range
- C = Engine Type
 - 01 = 1006-6
 - 02 = 1006-6T
 - 03 = 145T
 - 04 = 160T
 - 05 = 1006-6
 - 06 = 1006-6THR5
 - 07 = 1006-6T4
 - 09 = 160TW
 - 10 = Cummins 6BTA
- D = Transmission Speed
 - 3 = 30 km/h
 - 4 = 40 km/h
 - 5 = 55 km/h
 - 6 = 65 km/h
 - 7 = 75 km/h
- E = Vehicle Max. Speed
 - 30 = 30 km/h
- F = Serial Number

Typical Engine Identification Number

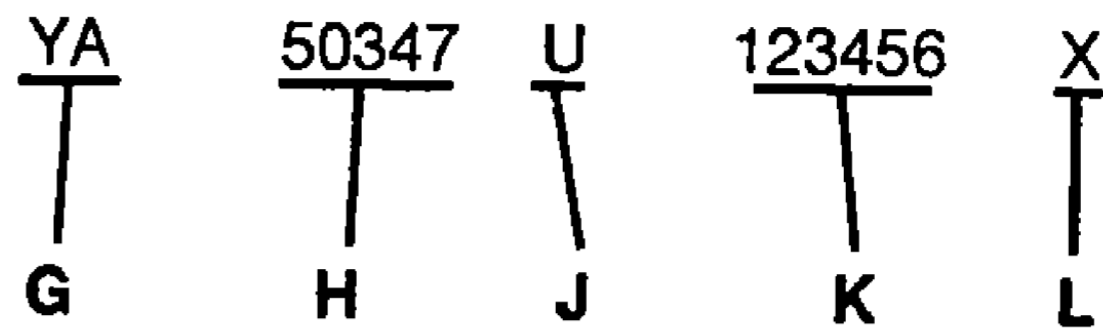

- G = Engine Type:-
 YA = Normally Aspirated
 YB = Turbocharged
 YD = Turbocharged/intercooled

- H = Build List Number (see **Engine Technical Data** for details)
- J = Country of Origin
- K = Engine Serial Number
- L = Year of Manufacture

Note: Cummins engines are identified by the model number 6BTA and a separate engine serial number.

Unit Identification

The serial number of each major unit is also stamped on the unit itself as shown below. If a major unit is replaced by a new one, the serial number on the plate will be wrong. Either stamp the new number of the unit on the identification plate, or simply stamp out the old number. This will prevent the wrong unit number being quoted when replacement parts are ordered.

- Perkins Engine
 - Cummins Engine
 - Transmission (Assembly of all three gearboxes)
 - Speed Gearbox
 - Front Axle
 - Rear Axle
- M
T
N
P
R
S

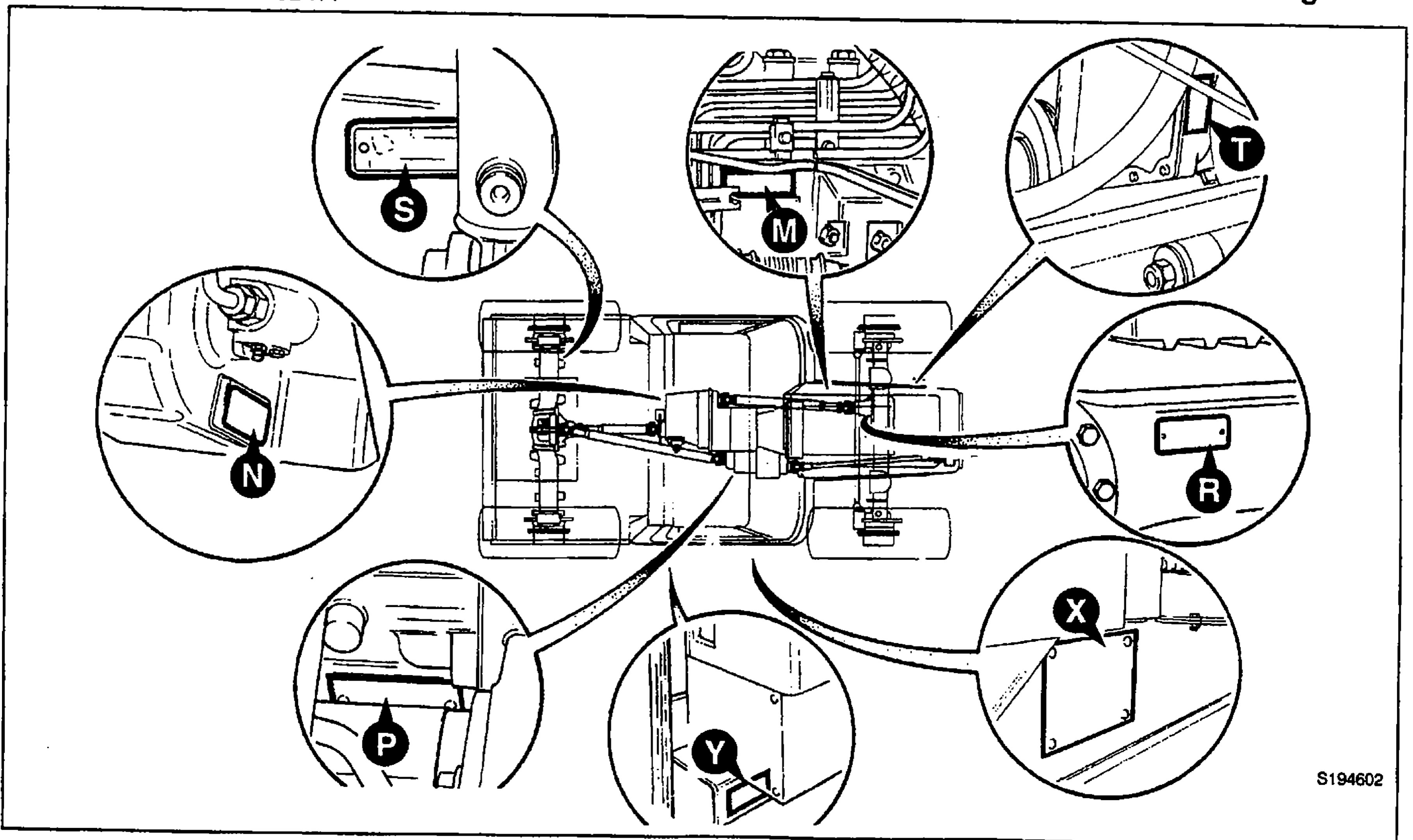

S194602

Torque Settings

Use only where no torque setting is specified in the text. Values are for dry threads and may be within three per cent of the figures stated. For lubricated threads the values should be REDUCED by one third.

Note: All bolts used on JCB machines are high tensile and must not be replaced by bolts of a lesser tensile specification.

Metric Grade 8.8 Bolts

* Dia.	Bolt size (mm)	Hexagon (A/F) mm	Torque Settings		
			Nm	kgf m	lbf ft
M5	(5)	8	7	0.7	5
M6	(6)	10	12	1.2	9
M8	(8)	13	28	3.0	21
M10	(10)	17	56	5.7	42
M12	(12)	19	98	10	72
M16	(16)	24	244	25	180
M18	(18)	27	350	36	258
M20	(20)	30	476	48	352
M24	(24)	36	822	84	607
M30	(30)	46	1633	166	1205
M36	(36)	55	2854	291	2105

Metric - All Internal Hexagon Headed Cap Screws

Diameter mm	Torque		
	Nm	kgf m	lbf ft
M3	2	0.2	1.5
M4	6	0.6	4.5
M5	11	1.1	8
M6	19	1.9	14
M8	46	4.7	34
M10	91	9.3	67
M12	159	16.2	117
M16	395	40	292
M18	550	56	406
M20	770	79	568
M24	1332	136	983

Hose and Pipe Connections

* All the hydraulic fittings on the Fastrac to machine number 636000 use the 'O' ring face seal system, with the 'O' ring located between the hose or pipe **B** and the adapter **A** as shown below. Adapters screwed into valve blocks etc. seal onto an 'O' ring which is compressed into a 45° seat machined in the face of the tapped port. Later machines have BSP hose connections without 'O' rings. Adapters are then sealed into components by means of bonded washers. See next page for torque settings.

* **Note:** Adapters have a UNF thread for the ORFS hose connection **B** but the thread **A** on the opposite end of the adapter may be either UNF or metric. Measure the thread diameter carefully before choosing the relevant torque setting table.

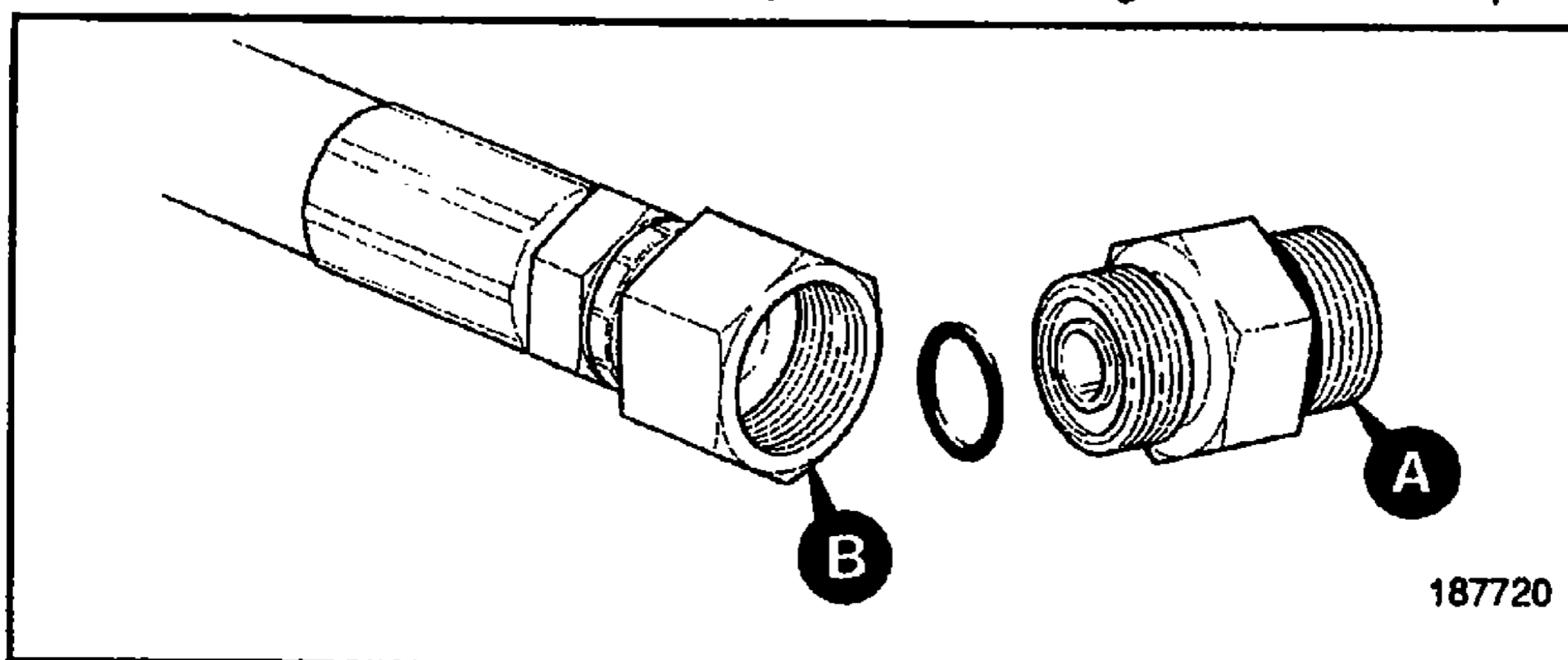

Torque Settings (continued)**'O' Ring Boss Adapters (Item A to machine number 636000)**

Nominal Diameter of UNF Thread (inches)	Torque Settings		
	Nm	kgf m	lbf ft
7/16	20	2.1	15
9/16	35	3.6	26
3/4	81	8.3	60
7/8	108	11.1	80
1 1/16	183	18.7	135
1 5/16	298	30.5	220
1 5/8	380	38.8	280
1 7/8	488	50	360

Nominal Diameter of Metric Thread (mm)	Torque Settings		
	Nm	kgf m	lbf ft
8	10	1.1	7
10	20	2.1	15
12	35	3.6	26
14	45	4.7	33
16	55	5.8	41
18	70	7.1	52
20	80	8.2	59
22	100	10.2	74
27	170	17.3	125
33	310	32	229
42	330	34	243
48	420	43	310
60	500	51	369

**ORFS Hydraulic Hose Connections
(Item B to machine number 636000)**

Nominal Thread Diameter (inches)	Torque Settings		
	Nm	kgf m	lbf ft
9/16	24	2.5	18
1 1/16	33	3.3	24
1 3/16	44	4.8	35
1	58	6.0	43
1 3/16	84	8.6	62
1 7/16	115	11.8	85
1 1 1/16	189	19.4	140
2	244	24.9	180

**Hydraulic Hose to Adapter Connections
(from machine number 636001)**

BSP Size (inches)	Torque Settings		
	Nm	kgf m	lbf ft
1/8	14	1.4	10
1/4	24	2.5	18
3/8	33	3.3	24
1/2	44	4.8	35
5/8	58	6.0	43
3/4	84	8.6	62
1	115	11.8	85
1 1/2	244	24.9	180

**Hydraulic Adapter into Component Connections
with bonded washers (from machine number 636001)**

BSP Size (inches)	Torque Settings		
	Nm	kgf m	lbf ft
1/8	20	2.1	15
1/4	34	3.4	25
3/8	75	7.6	55
1/2	102	10.3	75
5/8	122	12.4	90
3/4	183	18.7	135
1	203	20.7	150
1 1/2	305	31	225

Service Tools Numerical List

		Page No.			
			892/00284	Digital Tachometer	3 - 6
			892/00285	Oil Temperature Probe	3 - 6
			892/00286	Surface Temperature Probe	3 - 6
			892/00293	Connector Pipe	4 - 1
			892/00298	Fluke Multimeter	3 - 6
			892/00294	Connector Pipe	4 - 1
* 1370/0901Z	Nut	5 - 4	* 892/00311	Brake Test Kit	5 - 4
1406/0021	Bonded Washer	4 - 1	892/00312	Dummy End Plate	5 - 2
1604/0006	Adapter	4 - 1	892/00313	Clutch Alignment Tool	5 - 1
1604/0008	Adapter	4 - 1	892/00314	Accumulator Adapter	5 - 4
1606/0012	Adapter	4 - 1	892/00315	Engine Support Brackets	5 - 1
1606/0015	Adapter	4 - 1	892/00316	Hexagon Extension	4 - 2
1612/0006	Adapter	4 - 1	892/00317	Diagnostic Test Kit	4 - 2
4101/0202	Lock and Seal	3 - 2	892/00318	Hose and Adapter Kit	4 - 2
4101/0602	High Strength Retainer	3 - 2	892/00333	Heavy Duty Socket, 19 mm A/F	5 - 2
4101/0402	Threadlock	3 - 2	892/00334	Gland Seal Fitting Tool	4 - 2
4102/0502	High Strength Gasketing	3 - 2	892/00706	Test Probe	4 - 2
4102/0933	Clear Silicone Sealant	3 - 2	892/00800	Splitting Frame	5 - 1
4102/1201	Multi Gasket	3 - 2	892/00801	Clutch spanner	3 - 5
4102/1901	Loctite 577	3 - 2	892/00802	Rotor puller set	3 - 5
4102/2002	Loctite 518	3 - 2	892/00803	Rotor installer set	3 - 5
4102/2210	Clayton System Seal SC1251	3 - 2	892/00807	Front plate puller	3 - 5
4102/2309	Black Polyurethane Sealant	3 - 2	892/00808	Shaft protector	3 - 5
4103/2109	Ultra Fast Adhesive	3 - 2	892/00812	Drive Coupling Spanner	5 - 1
4104/0101	Activator N (Aerosol)	3 - 2	892/00817	Heavy Duty Socket, 17 mm A/F	5 - 2
4104/0102	Activator N (Bottle)	3 - 2	892/00819	Heavy Duty Socket, 15 mm A/F	5 - 2
4104/0601	Super Clean Solvent	3 - 2	892/00842	Glass Lifter	3 - 3
4104/1203	Active Wipe 205 (250 g)	3 - 2	892/00843	Folding Stand	3 - 3
4104/1206	Active Wipe 205 (30 ml)	3 - 2	892/00844	Long Knife	3 - 4
4104/1310	Hand Cleaner	3 - 3	892/00845	Cartridge Gun	3 - 3
4201/4906	Black Primer	3 - 2	892/00846	Glass Extractor Handles	3 - 4
477/00437	Gearbox Lifting Adapter	5 - 2	892/00847	Nylon Spatula	3 - 5
816/15118	Adapter/Test Point	4 - 1	892/00848	Wire Starter	3 - 4
816/20008	Adapter	4 - 1	892/00849	Braided Cutting Wire	3 - 4
816/20013	Adapter	4 - 1	* 892/00864	PD90 Axle Locknut Spanner	5 - 3
816/55040	Adapter/Test Point	4 - 1	* 892/00871	Frame	5 - 4
* 892/00041	Deglazing Tool	5 - 5	* 892/00874	Brace	5 - 4
892/00078	Connector	4 - 1	* 892/00875	Bar	5 - 4
892/00137	Micro Bore Hose	4 - 2	* 892/00876	Block	5 - 4
892/00174	Measuring Cup	5 - 2	892/00882	Socket	3 - 6
892/00179	Bearing Press	5 - 1	* 892/00883	Spanner	5 - 4
892/00223	Hand Pump	4 - 2	* 892/00884	'C' Spanner	5 - 4
892/00224	Impulse Extractor	5 - 2	* 892/00891	Oil Seal Insertion Tool	5 - 3
892/00225	Adapter for Impulse Extractor	5 - 1	* 892/00892	Speed Gearbox Locking Tool	5 - 3
892/00253	Pressure Test Kit	4 - 1	992/12300	Mobile Oven	3 - 3
892/00255	Adapter/Test Point	4 - 1	992/12400	Static Oven	3 - 3
892/00256	Adapter/Test Point	4 - 1	992/12600	Static Oven	3 - 4
892/00257	Adapter/Test Point	4 - 1	992/12800	Cut-out Knife	3 - 4
892/00258	Adapter/Test Point	4 - 1	992/12801	'L' Blades	3 - 4
892/00259	Adapter/Test Point	4 - 1	926/15500	Rubber Spacer Blocks	3 - 5
892/00260	Adapter/Test Point	4 - 1	993/45400	Torque Multiplier	5 - 2
892/00261	Adapter/Test Point	4 - 1	993/55700	Direct Glazing Kit	3 - 2
892/00262	Adapter/Test Point	4 - 1 & 4 - 2	* 993/59300	Pressure Test Adapter/Clamp	5 - 3
892/00263	Adapter/Test Point	4 - 1	993/69800	Seal Kit	4 - 1
892/00264	Adapter/Test Point	4 - 1	* 993/85700	Battery Tester	3 - 6
892/00265	Adapter/Test Point	4 - 1	FABLM10	Ball End Allen Key	4 - 2
892/00268	Flow Monitoring Unit	4 - 1	FXW11A	Wobble Drive Extension	4 - 2
892/00269	Sensor Head	4 - 1			
892/00270	Load Valve	4 - 1			
892/00271	Adapter	4 - 1			
892/00272	Adapter	4 - 1			
892/00273	Sensor Head	4 - 1			
892/00274	Adapter	4 - 2			
892/00275	Adapter	4 - 1			
892/00276	Adapter	4 - 1			
892/00277	Adapter	4 - 1			
892/00278	Gauge 0 - 40 bar	4 - 2			
892/00279	Gauge 0 - 400 bar	4 - 2			
892/00281	Avo Meter	3 - 6			
892/00282	Shunt	3 - 6			
892/00283	Tool Kit Case	3 - 6			

The following parts are replacement items for kits and would normally be included in the kit numbers above.

Replacement items for kit no. 892/00253

892/00201	Gauge 0 - 20 bar	4 - 1
892/00202	Gauge 0 - 40 bar	4 - 1
892/00203	Gauge 0 - 400 bar	4 - 1
892/00254	Hose	4 - 1

Sealing and Retaining Compounds

JCB Multigasket	A medium strength sealant suitable for all sizes of gasket flanges, and for hydraulic fittings of 25-65 mm diameter.	4102/1212	50ml
JCB Threadlocker	For threads of 50mm diameter upwards, eg. suction strainer.	4101/0451	50ml
JCB Threadlocker (High Strength)	A high strength locking fluid for use with threaded components. Gasketing for all sizes of flange where the strength of the joint is important.	4102/0551	50ml
JCB Retainer (High Strength)	For all retaining parts which are unlikely to be dismantled.	4101/0651	50ml
JCB Threadlocker And Sealer	A medium strength locking fluid for sealing and retaining nuts, bolts, and screws up to 50 mm diameter, and for hydraulic fittings up to 25 mm diameter.	4101/0250 4101/0251	10ml 50ml
JCB Threadlocker And Sealer (High Strength)	A high strength locking fluid for sealing and retaining nuts, bolts, and screws up to 50 mm diameter, and for hydraulic fittings up to 25 mm diameter.	4101/0550 4101/0552	10ml 200ml
JCB Threadseal	A medium strength thread sealing compound.	4102/1951	50ml
JCB Activator	A cleaning primer which speeds the curing rate of anaerobic products.	4104/0251 4104/0253	Aerosol (1 ltr) Bottle (200 ml)
JCB Cleaner/Degreaser	For degreasing components prior to use of anaerobic adhesives and sealants.	4104/1557	Aerosol (400ml)
Direct Glazing Kit	For one pane of glass; comprises items marked † below plus applicator nozzle etc.		
† Ultra Fast Adhesive	For direct glazing	4103/2109	310 ml
† Active Wipe 205	For direct glazing	4104/1203	250 g
† Black Primer 206J	For direct glazing	4201/4906	30 ml
Clear Silicone Sealant	To seal butt jointed glass.	4102/0901	

Service Tools (continued)

Body and Framework (continued)

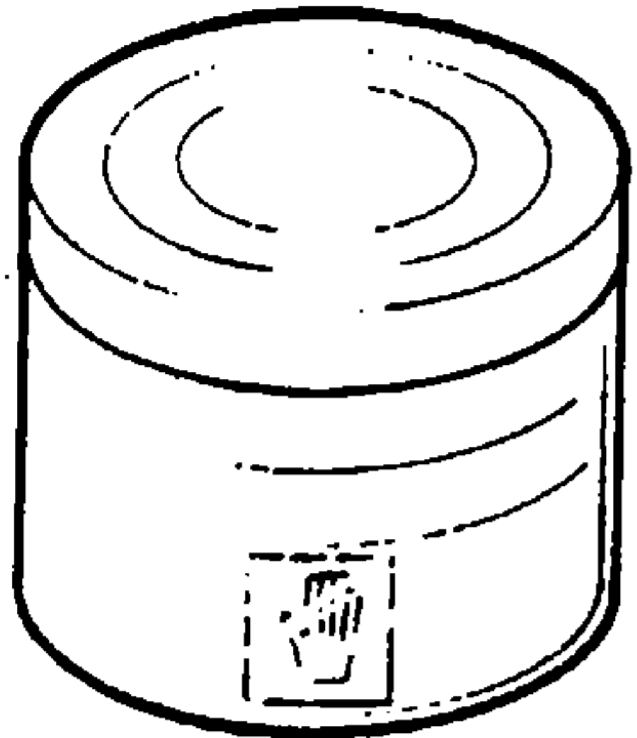

S186240

Hand Cleaner - special blend for the removal of polyurethane adhesives.

JCB part number - 4104/1310 (454g; 1lb tub)

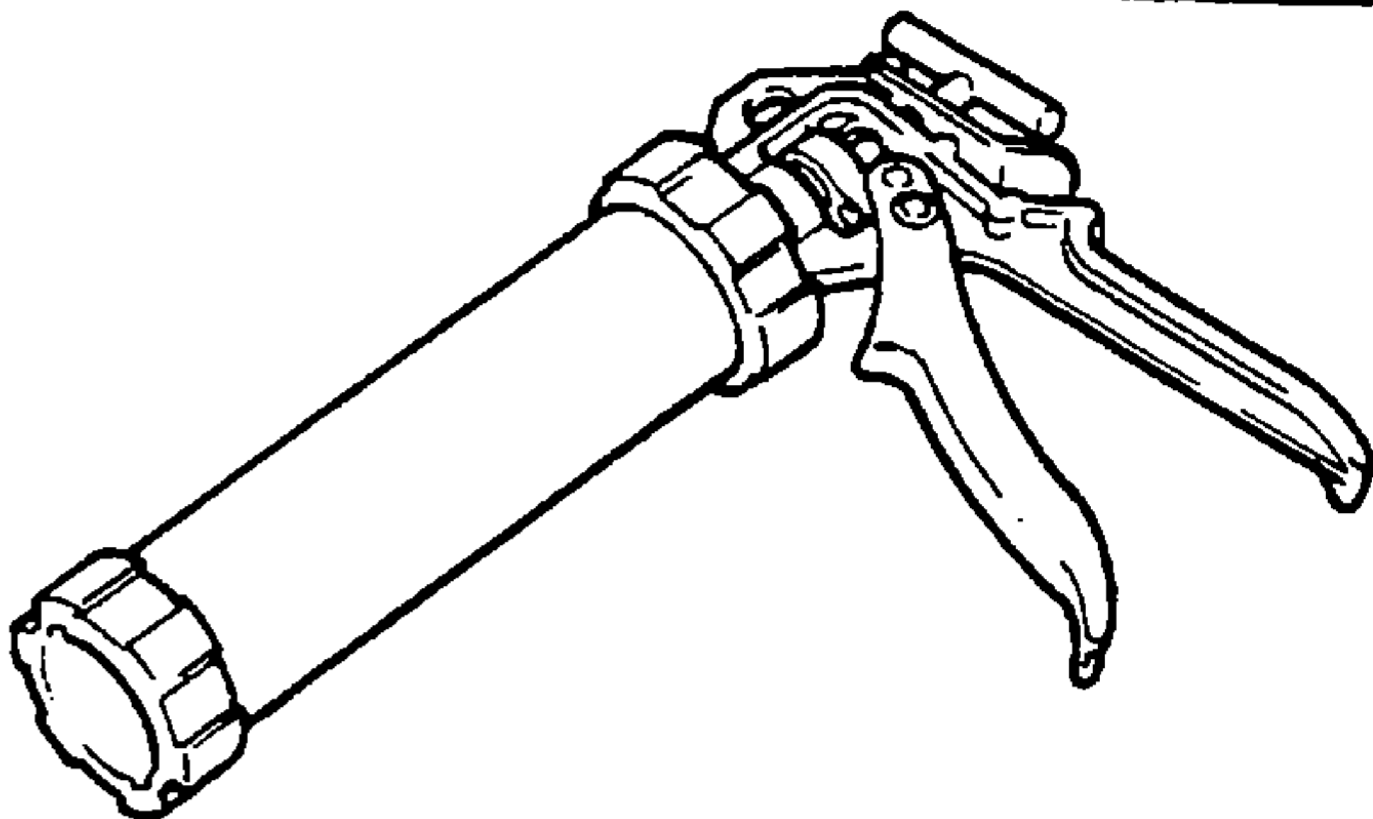

S186270

Cartridge Gun - hand operated - essential for the application of sealants, polyurethane materials etc.

JCB part number - 892/00845

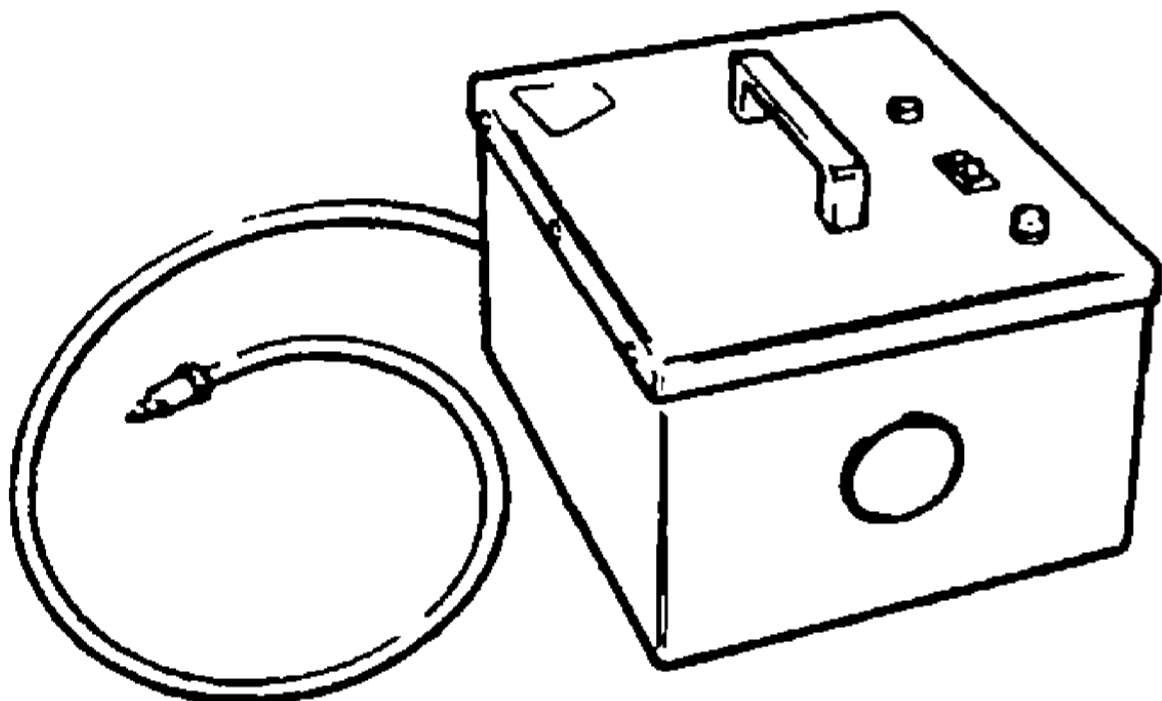

S186250

12V Mobile Oven - 1 cartridge capacity - required to pre-heat adhesive prior to use. It is fitted with a male plug (703/23201) which fits into a female socket (715/04300).

JCB part number - 992/12300

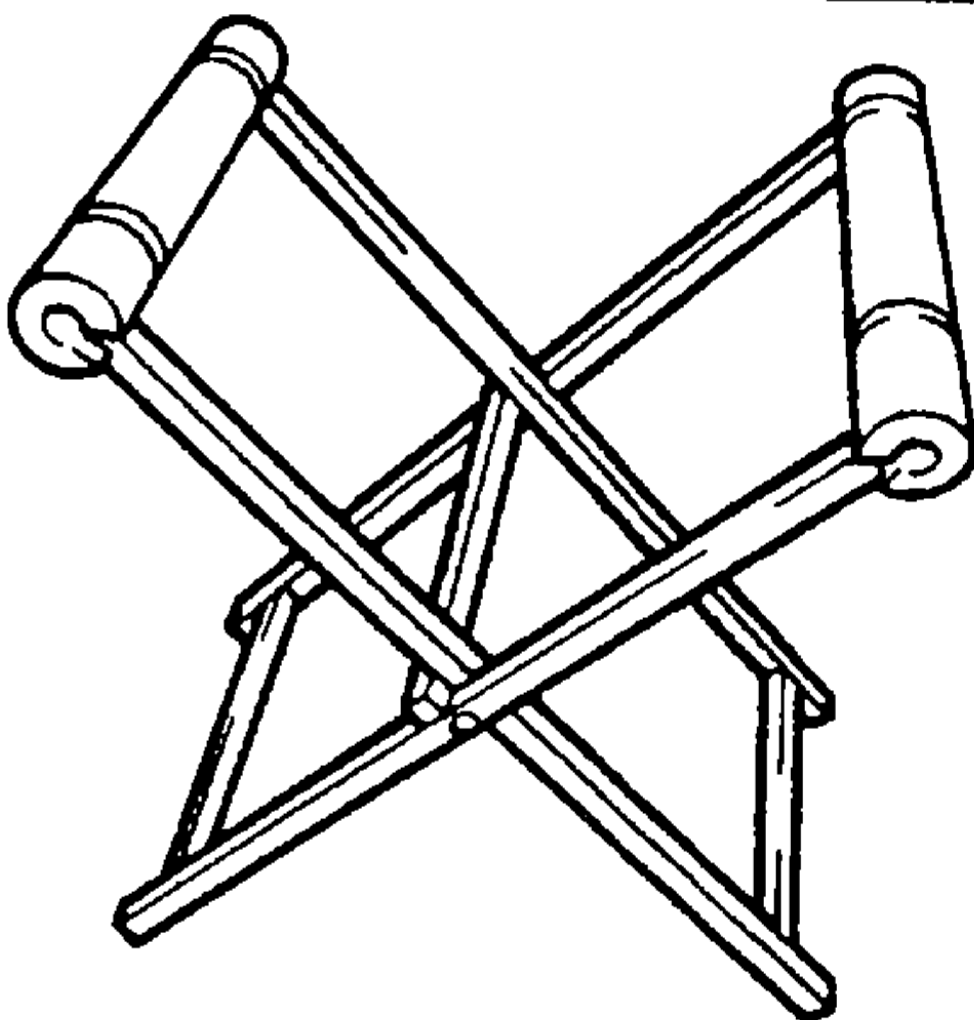

S186280

Folding Stand for Holding Glass - essential for preparing new glass prior to installation.

JCB part number - 892/00843

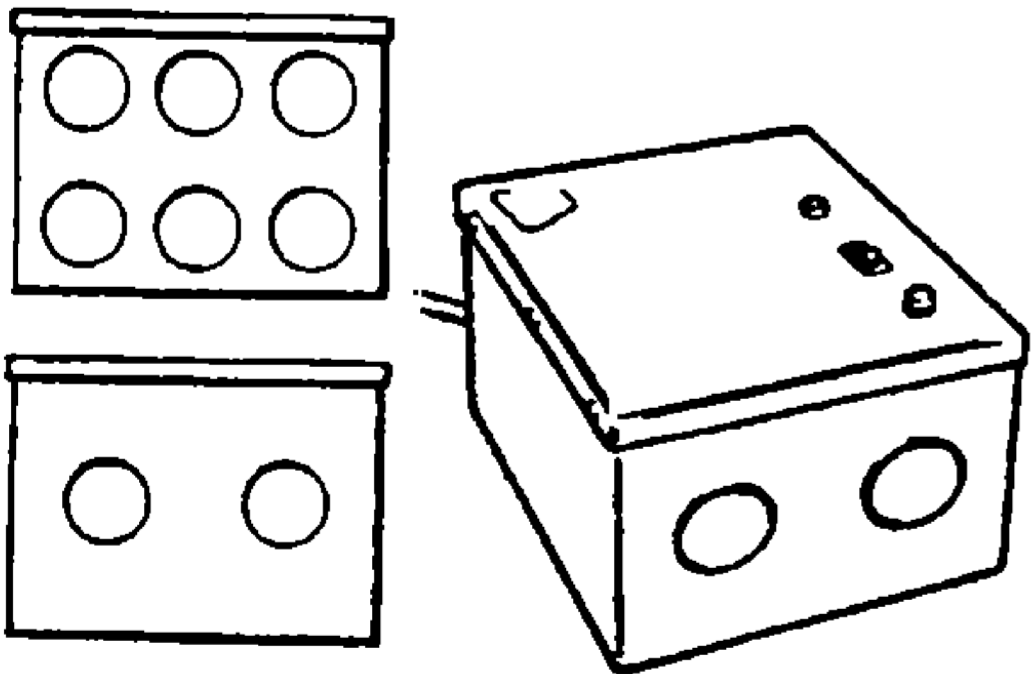

S186260

240V Static Oven - available with 2 or 6 cartridge capacity - required to pre-heat adhesive prior to use. No plug supplied. Note: 110V models available upon request - contact JCB Technical Service

JCB part number:
 992/12400 - 2 cartridge x 240V
 992/12600 - 6 cartridge x 240V

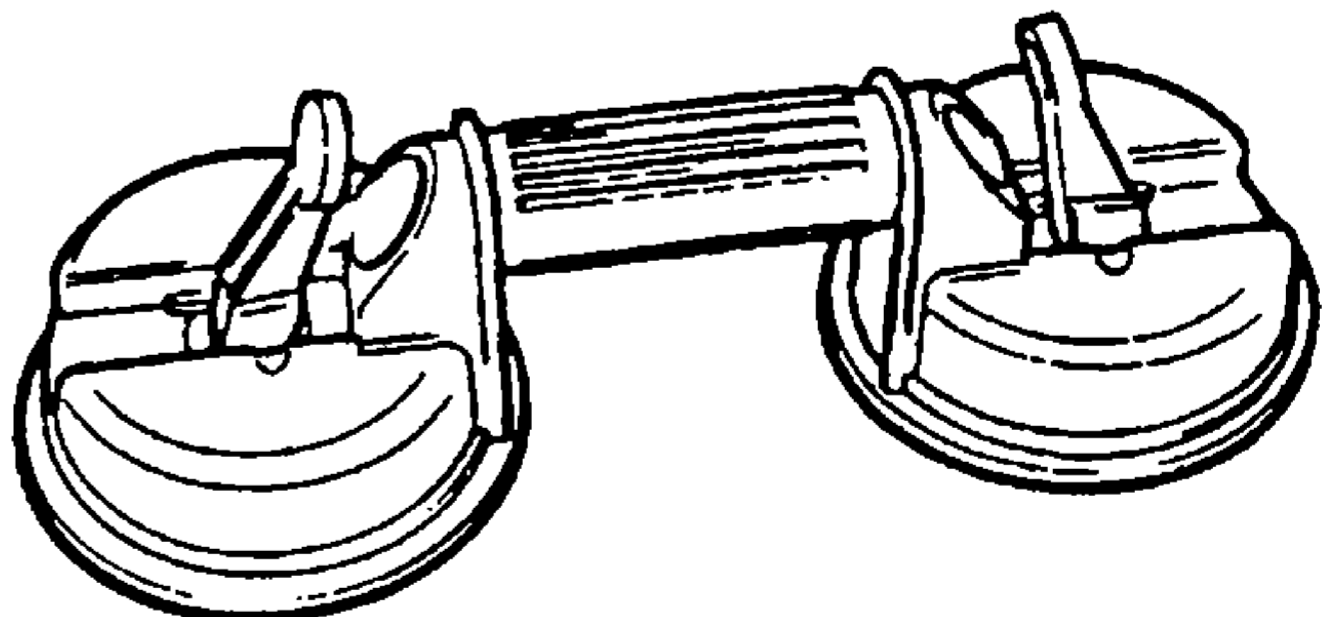

S186300

Glass Lifter - minimum 2 off - essential for glass installation, 2 required to handle large panes of glass. Ensure suction cups are protected from damage during storage.

JCB part number - 892/00842

Service Tools (continued)

Body and Framework (continued)

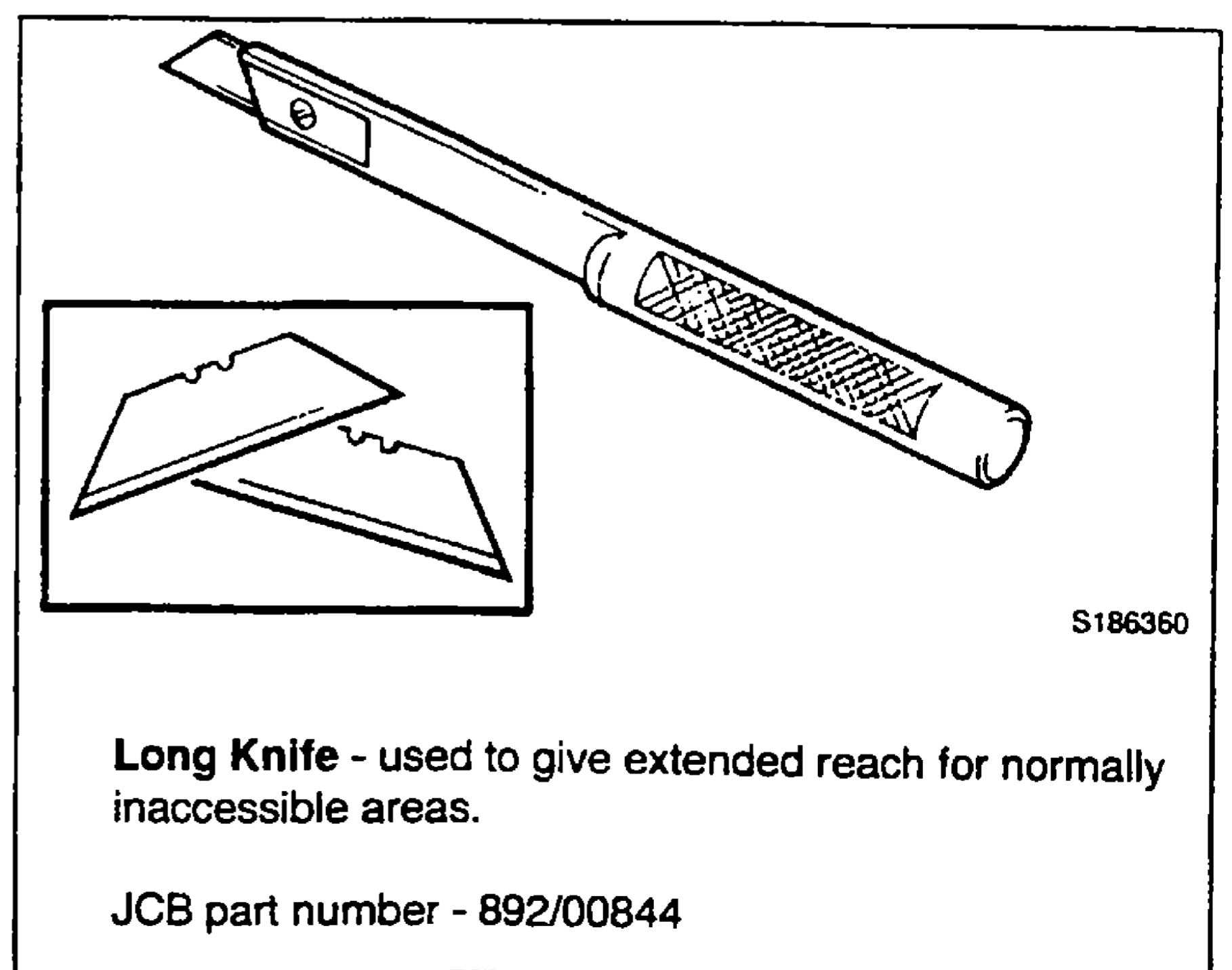
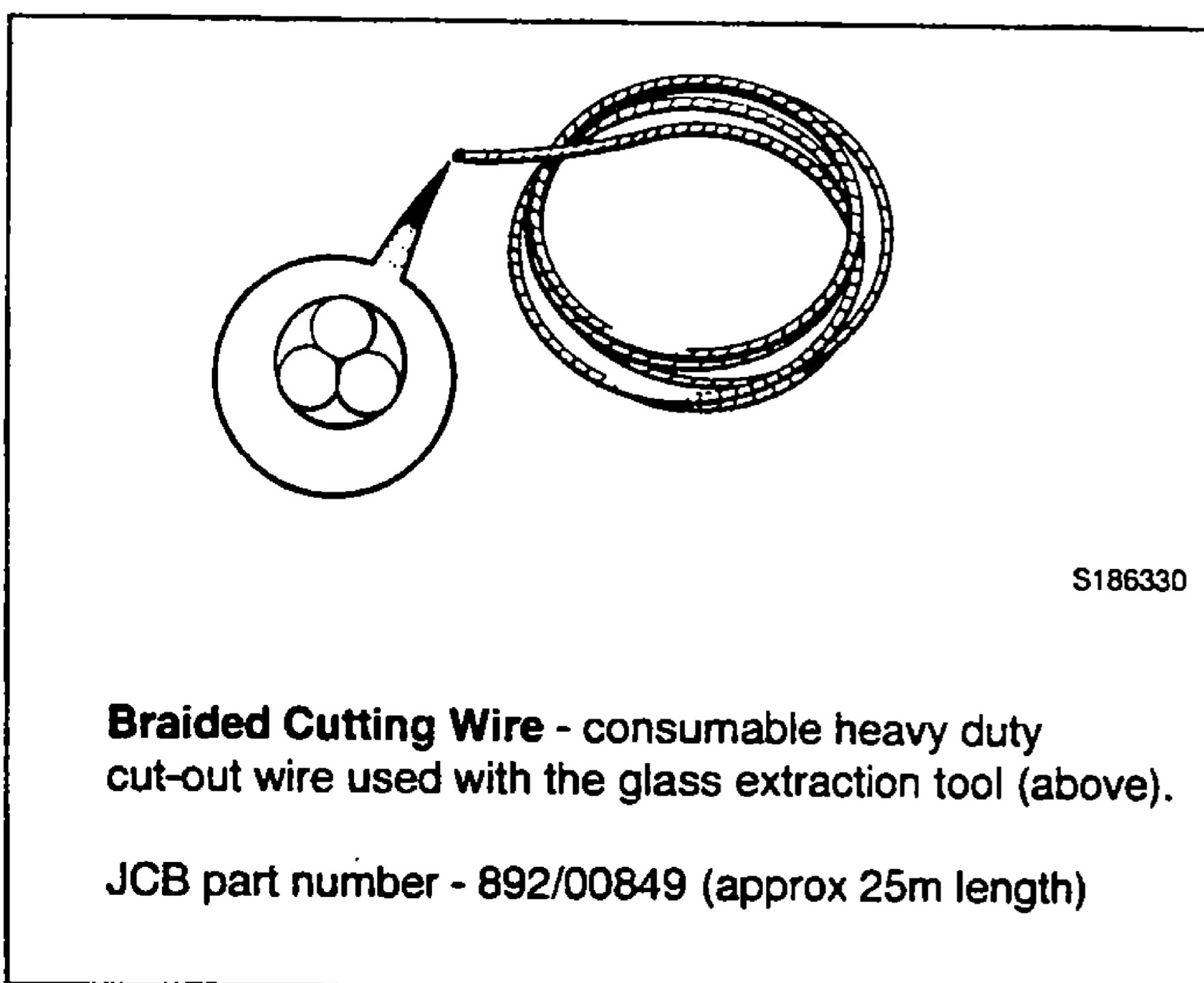
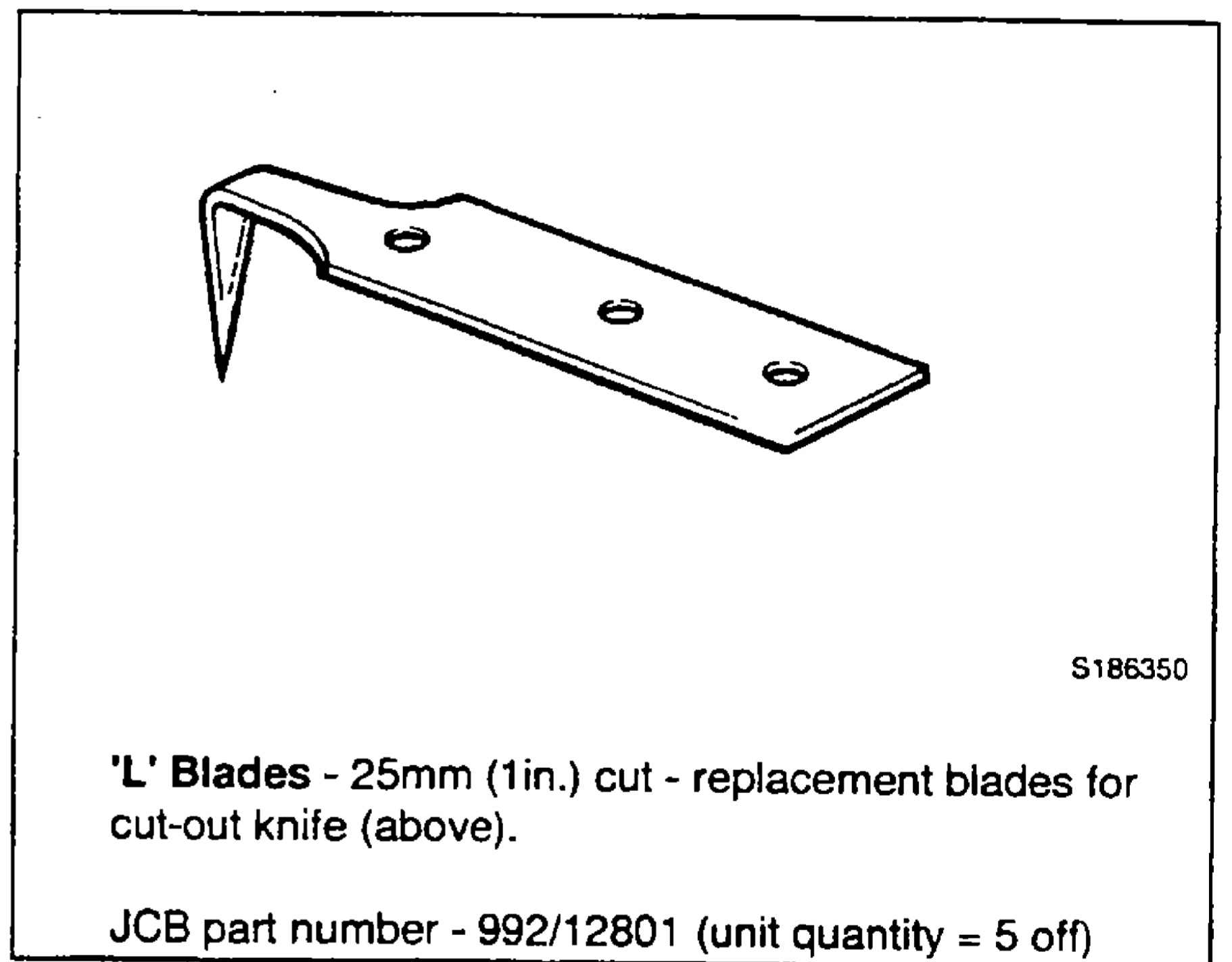
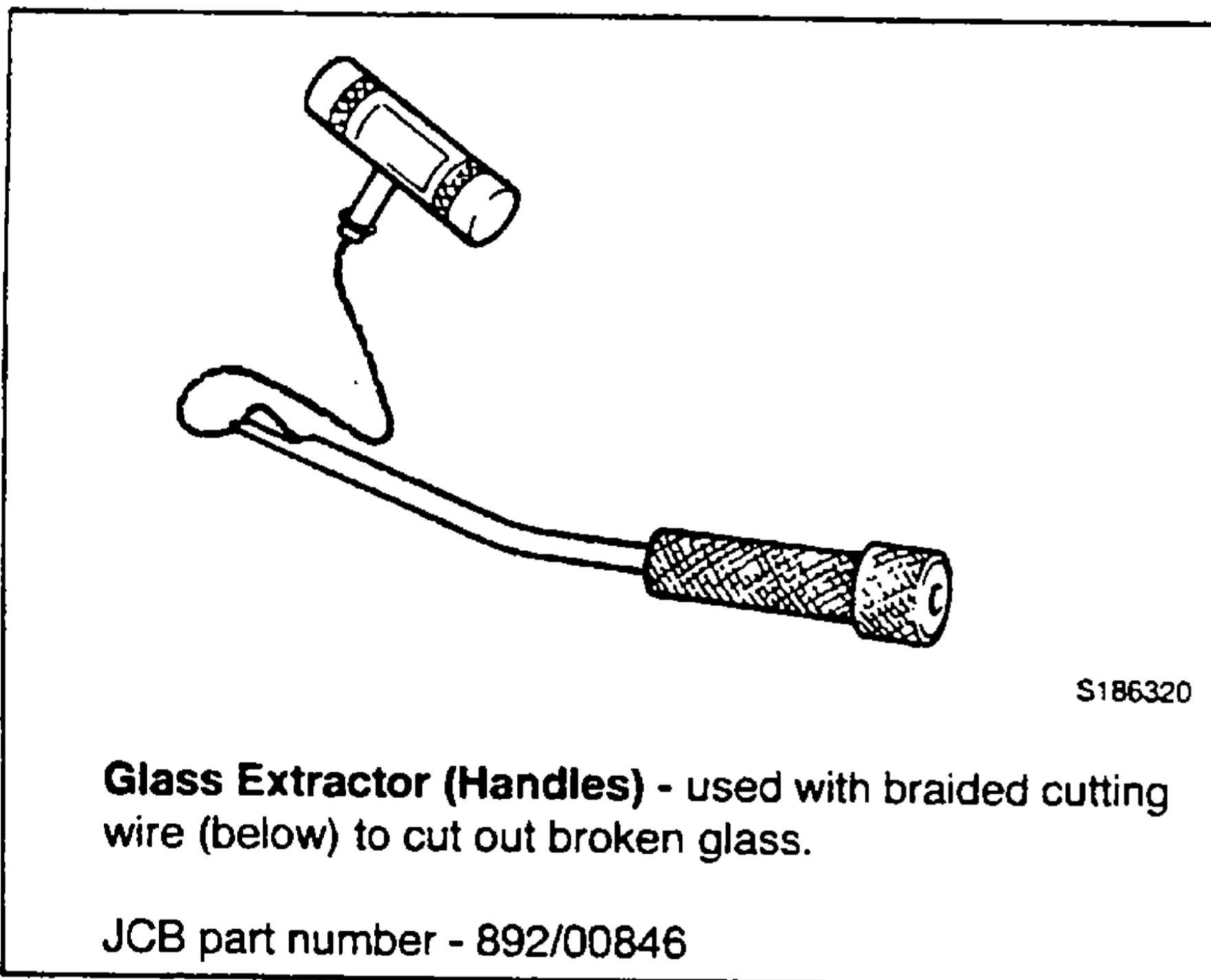
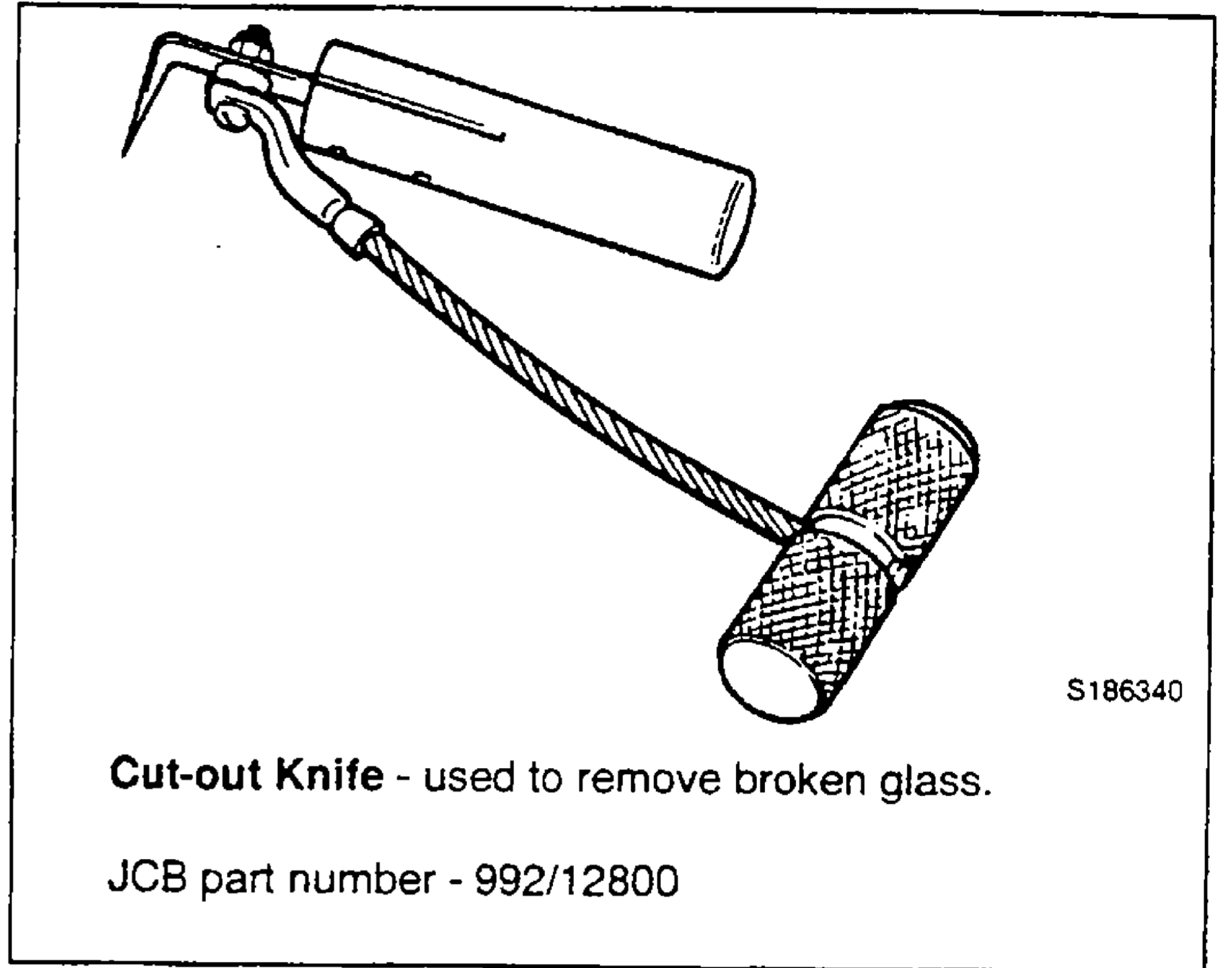
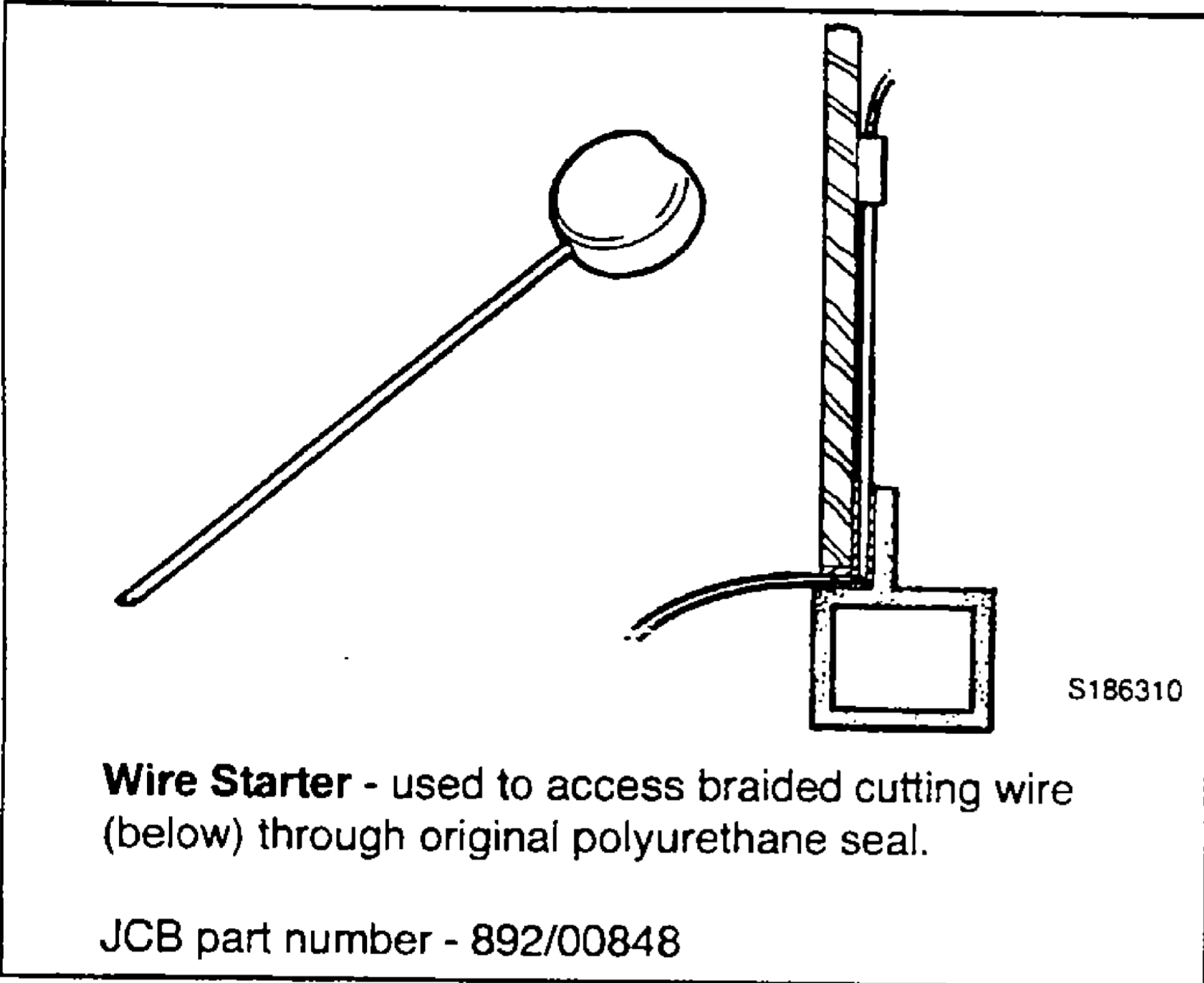

Service Tools (continued)

Body and Framework (continued)

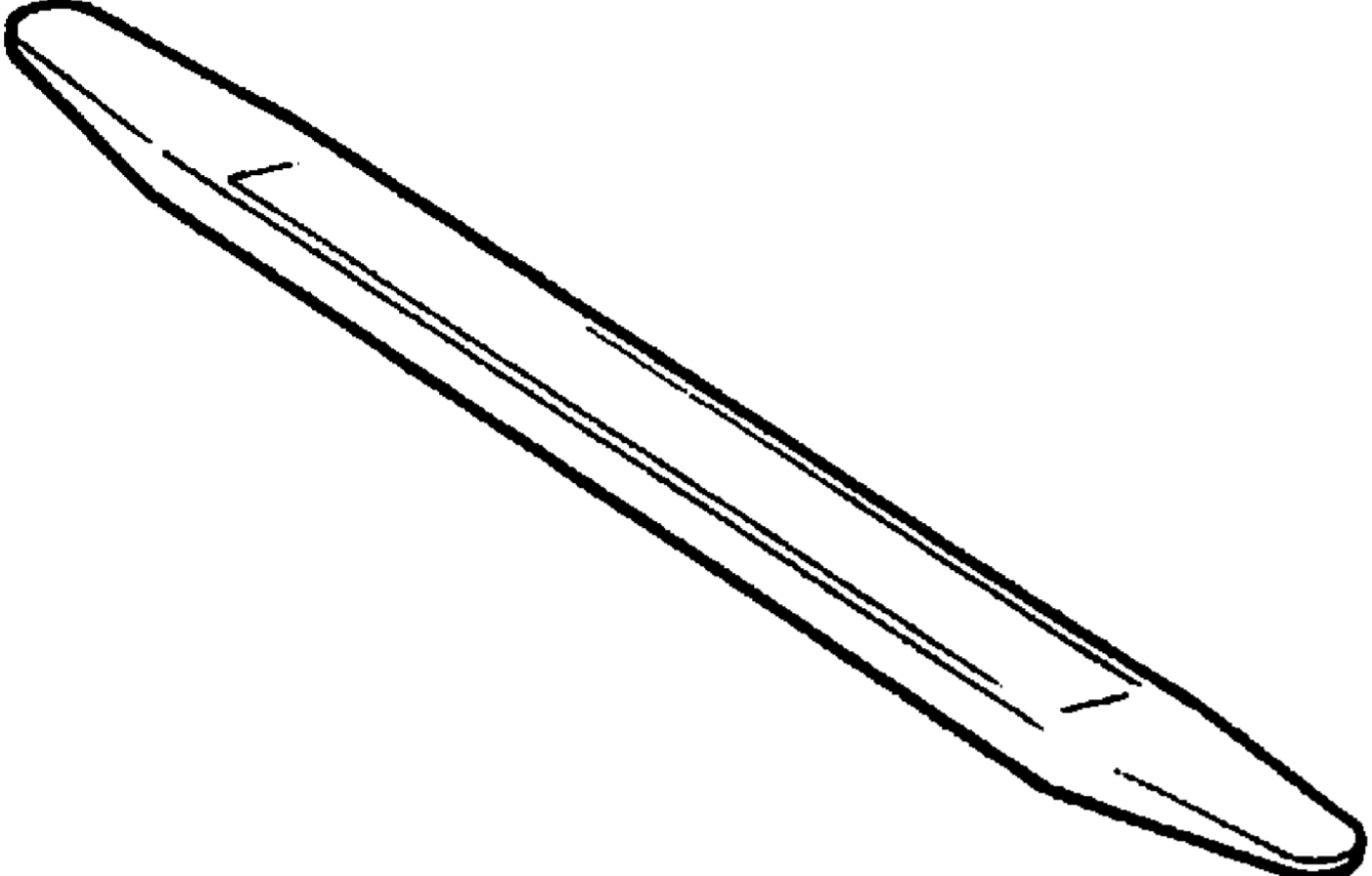

Nylon Spatula - general tool used for smoothing sealants - also used to re-install glass in rubber glazing because metal tools will chip the glass edge.

JCB part number - 892/00847

S186470

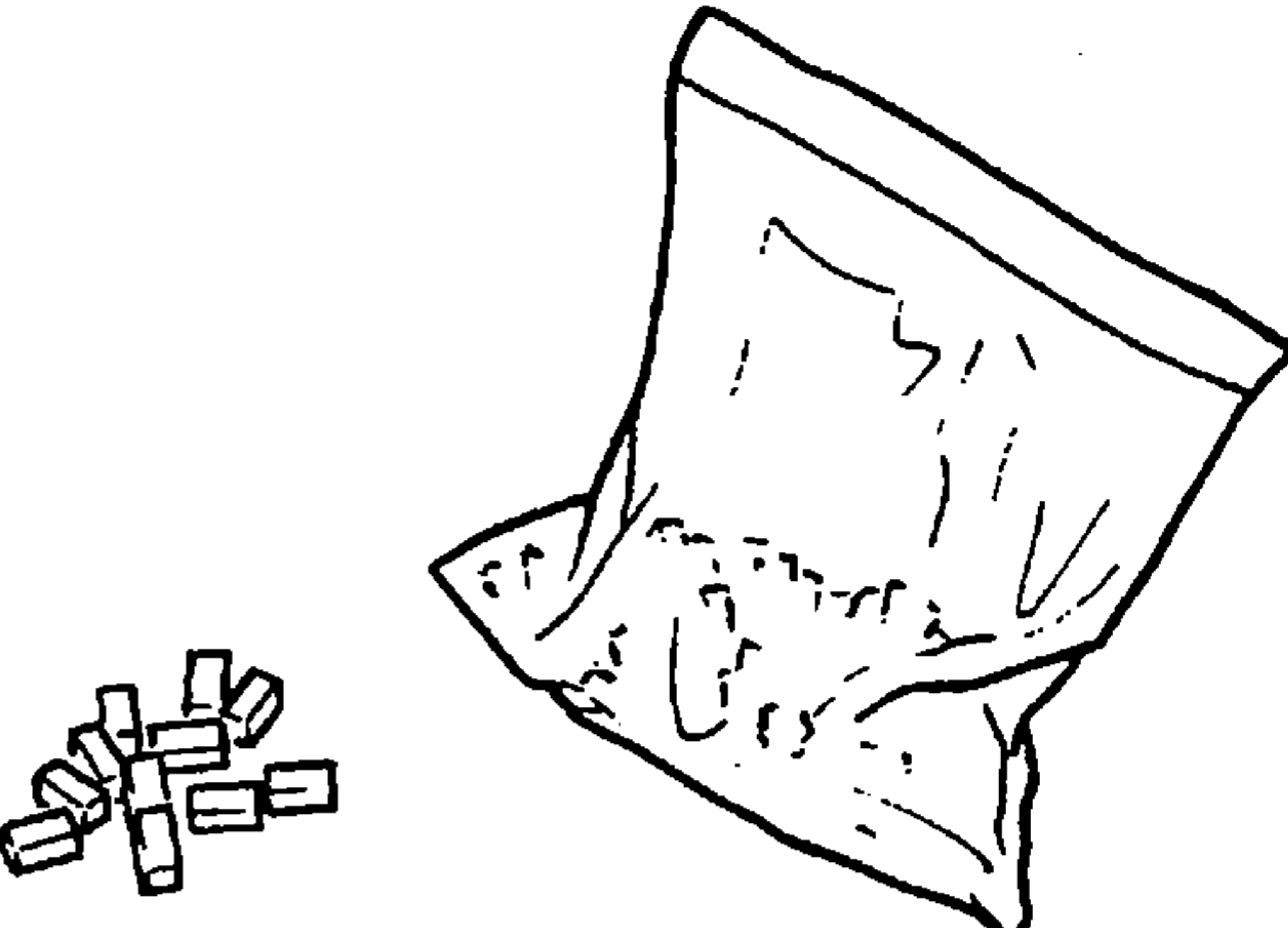

Rubber Spacer Blocks - used to provide the correct set clearance between glass edge and cab frame.

JCB part number - 926/15500
(unit quantity = 500 off)

S186550

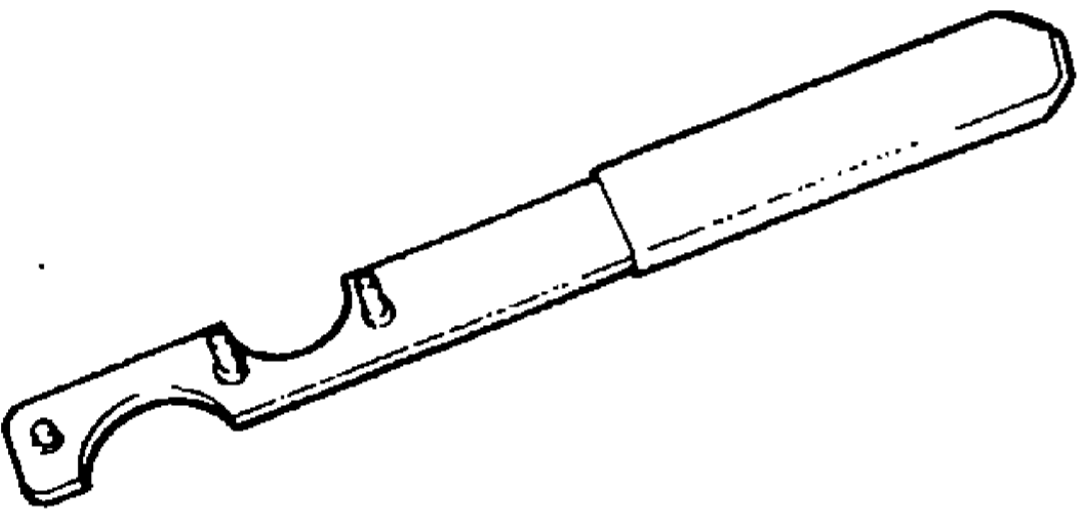

892/00801 Clutch spanner for air conditioning compressor

S200940

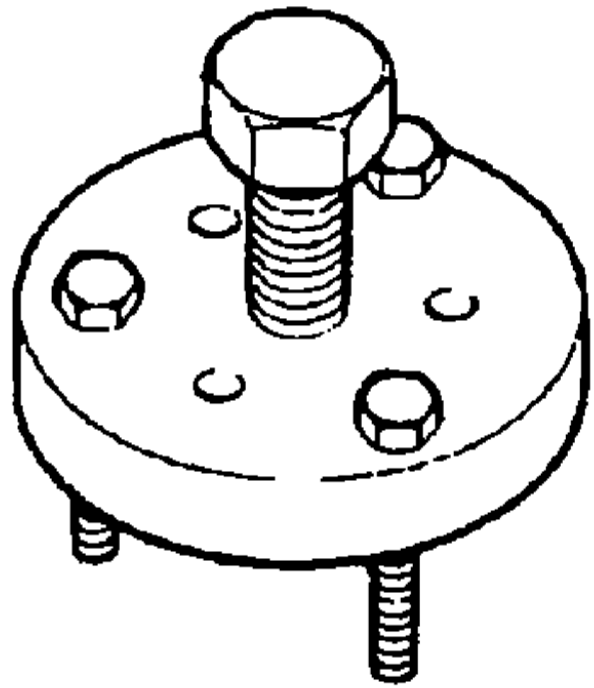

892/00807 Front plate puller for air conditioning compressor

S200970

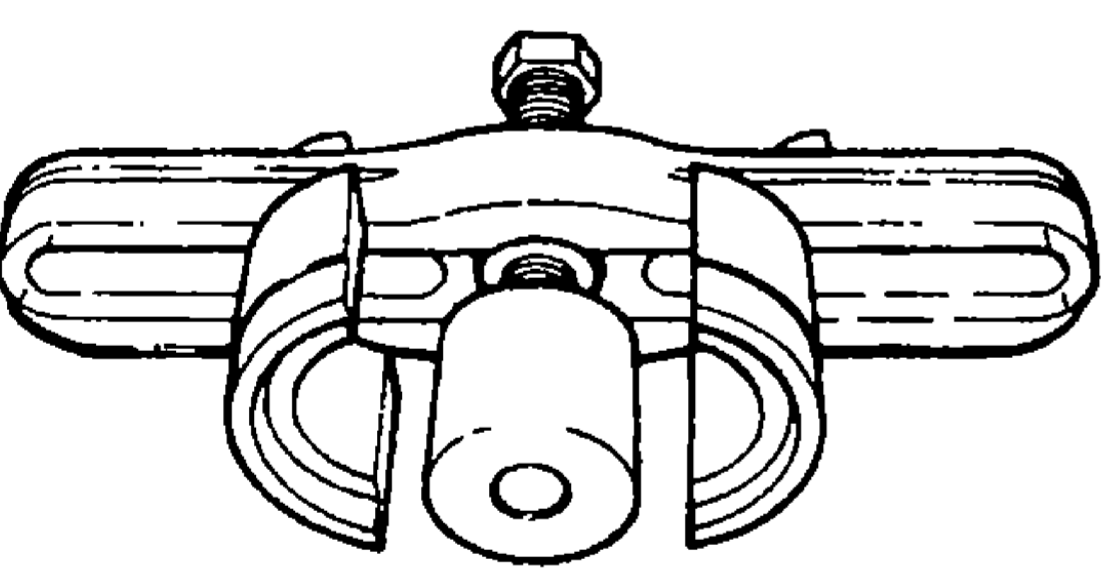

892/00802 Rotor puller set for air conditioning compressor

S200950



892/00808 Shaft protector for air conditioning compressor

S200980

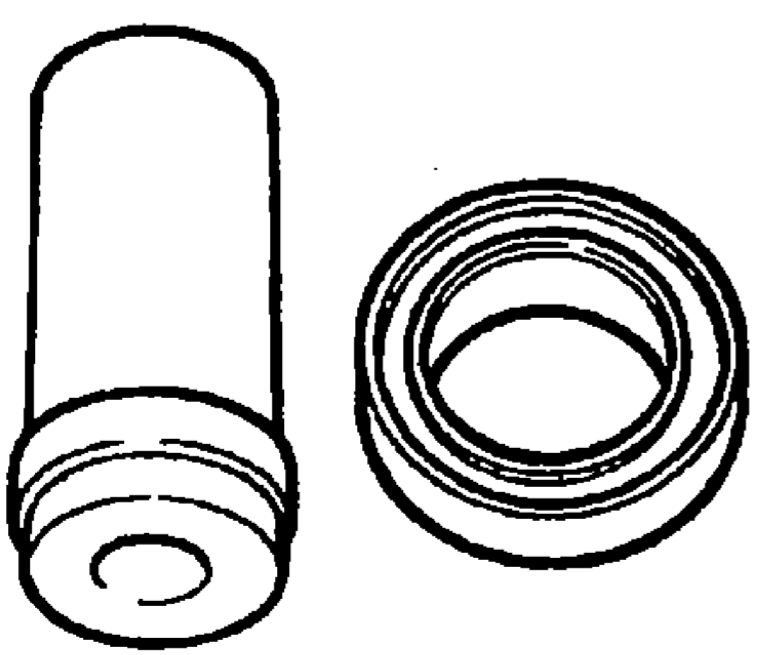

892/00803 Rotor installer set for air conditioning compressor

S200960

Service Tools (continued)

Section C - Electrics

1 892/00283 Tool Kit Case

2 892/00281 AVO Meter

3 892/00286 Surface Temperature Probe

4 892/00284 Microtach Digital Tachometer

5 892/00282 100 Amp Shunt - open type

6 892/00285 Hydraulic Oil Temperature Probe

7 892/00298 Fluke 85 Multimeter

188230

993/85700 Battery Tester 239510

892/00882 Socket for Pulley Nut on Magneti Marelli Alternator.

S216770

Service Tools (cont'd)

Section E - Hydraulics

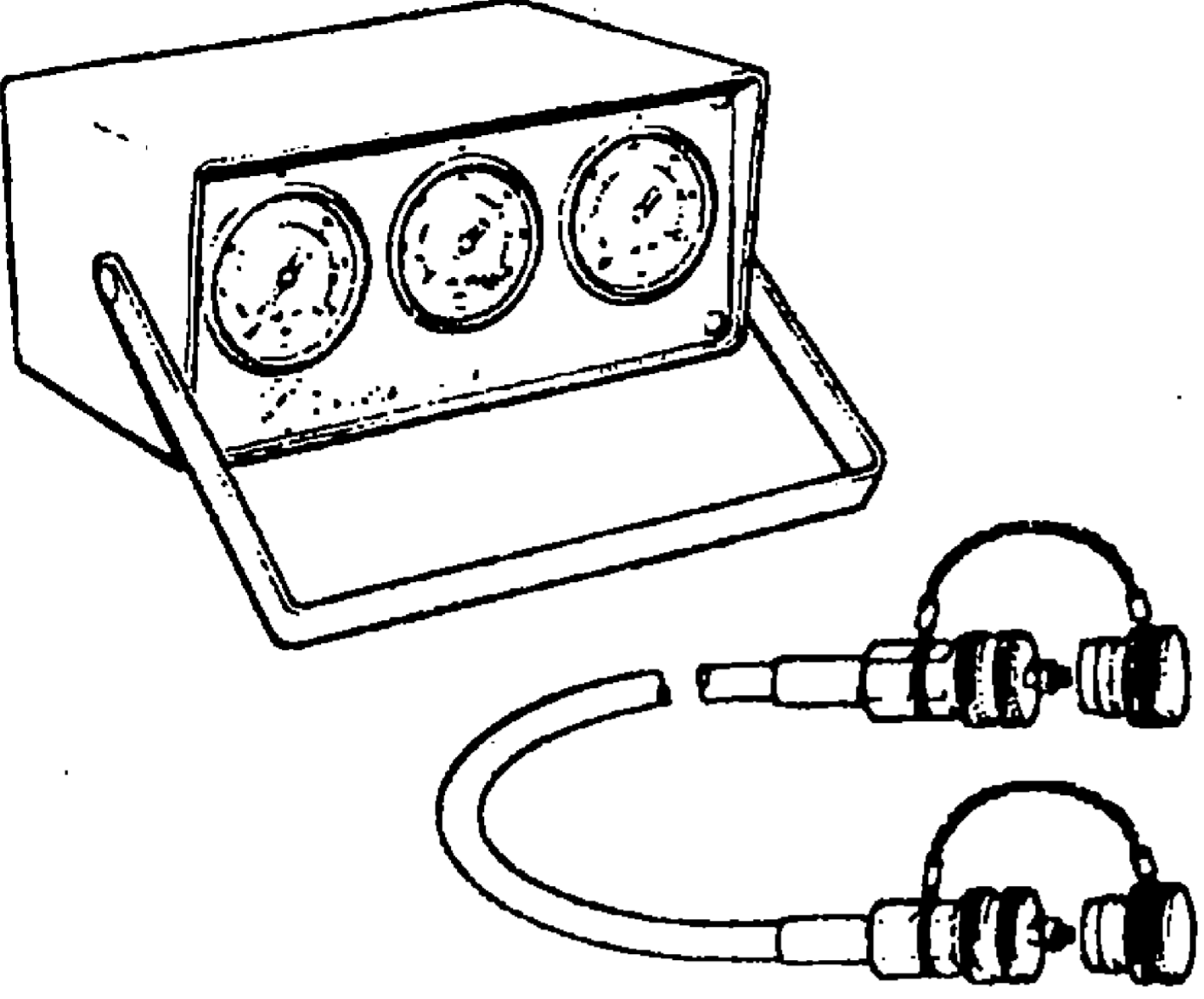

Hydraulic Circuit Pressure Test Kit

892/00253	Pressure Test Kit
892/00201	Replacement Gauge 0-20 bar (0-300 lbf/in ²)
892/00202	Replacement Gauge 0-40 bar (0-600 lbf/in ²)
892/00203	Replacement Gauge 0-400 bar (0-6000 lbf/in ²)
892/00254	Replacement Hose
:993/69800	Seal Kit for 892/00254 (can also be used with probe 892/00706)

S188120

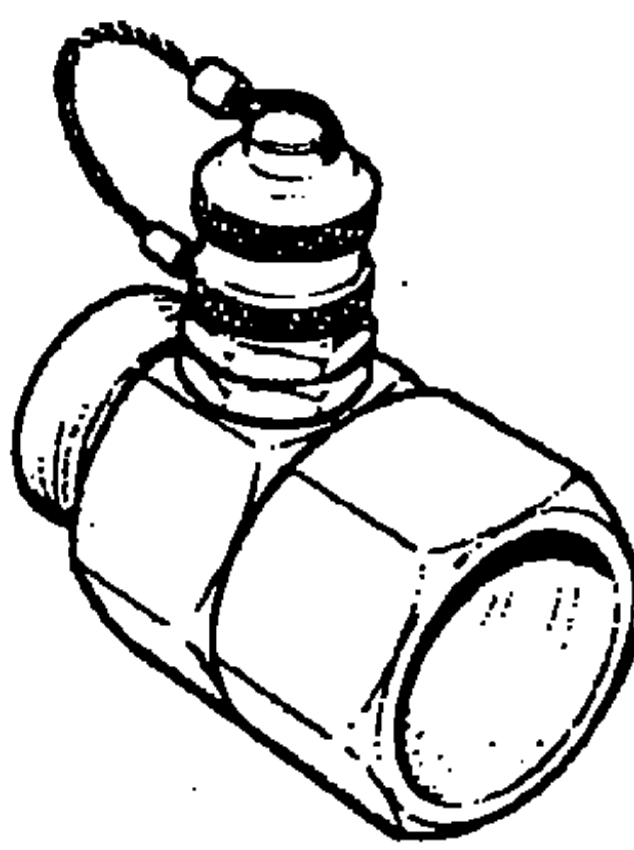

Pressure Test 'T' Adapters

892/00262	1/4 in M BSP x 1/4 in F BSP x Test Point
816/55038	3/8 in M BSP x 3/8 in F BSP x Test Point
816/55040	1/2 in M BSP x 1/2 in F BSP x Test Point
892/00263	5/8 in M BSP x 5/8 in F BSP x Test Point
892/00264	3/4 in M BSP x 3/4 in F BSP x Test Point
892/00265	1 in M BSP x 1 in F BSP x Test Point

S188130

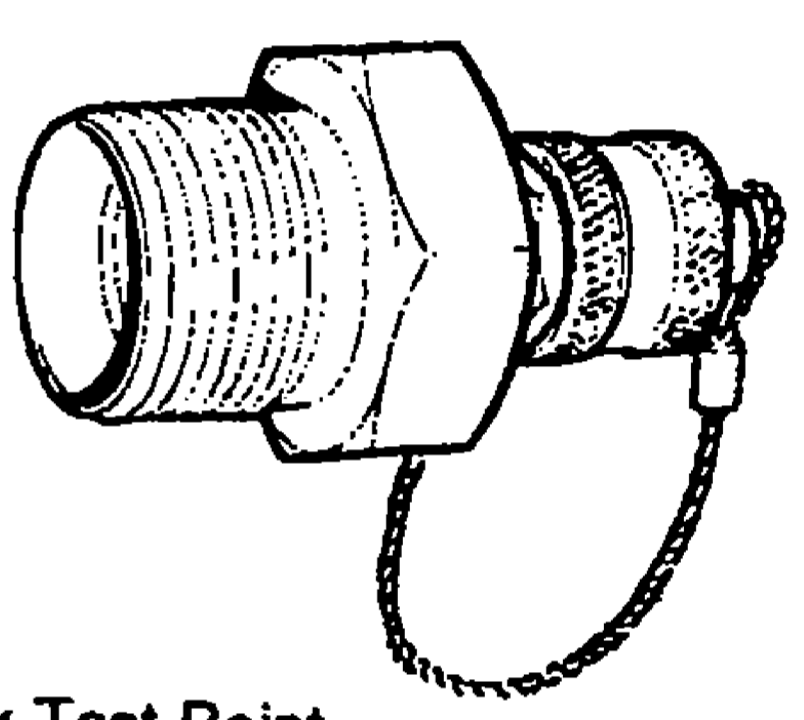

Pressure Test Adapters

892/00255	1/4 in BSP x Test Point
892/00256	3/8 in BSP x Test Point
892/00257	1/2 in BSP x Test Point
892/00258	5/8 in BSP x Test Point
816/15118	3/4 in BSP x Test Point
892/00259	1 in BSP x Test Point
892/00260	1.1/4 in BSP x Test Point
892/00261	5/8 in UNF x Test Point

S200140

Flow Test Equipment

892/00268	Flow Monitoring Unit
892/00269	Sensor Head 0 - 100 l/min (0 - 22 UK gal/min)
892/00293	Connector Pipe
892/00270	Load Valve
1406/0021	Bonded Washer
1604/0006	Adapter 3/4 in M x 3/4 in M BSP
1612/0006	Adapter 3/4 in F x 3/4 in M BSP
892/00271	Adapter 3/4 in F x 5/8 in M BSP
892/00272	Adapter 5/8 in F x 3/4 in M BSP
816/20008	Adapter 3/4 in F x 1/2 in M BSP
892/00275	Adapter 1/2 in F x 3/4 in M BSP
892/00276	Adapter 3/4 in F x 3/8 in M BSP
892/00277	Adapter 3/8 in F x 3/4 in M BSP
892/00273	Sensor Head 0 - 380 l/min
892/00294	Connector Pipe
1606/0015	Adapter 1.1/4 in M BSP x 1 in M BSP
892/00078	Connector 1 in F x 1 in F BSP
1604/0008	Adapter 1 in M x 1 in M BSP
1606/0012	Adapter 1 in M x 3/4 in M BSP
816/20013	Adapter 3/4 in F x 1 in M BSP

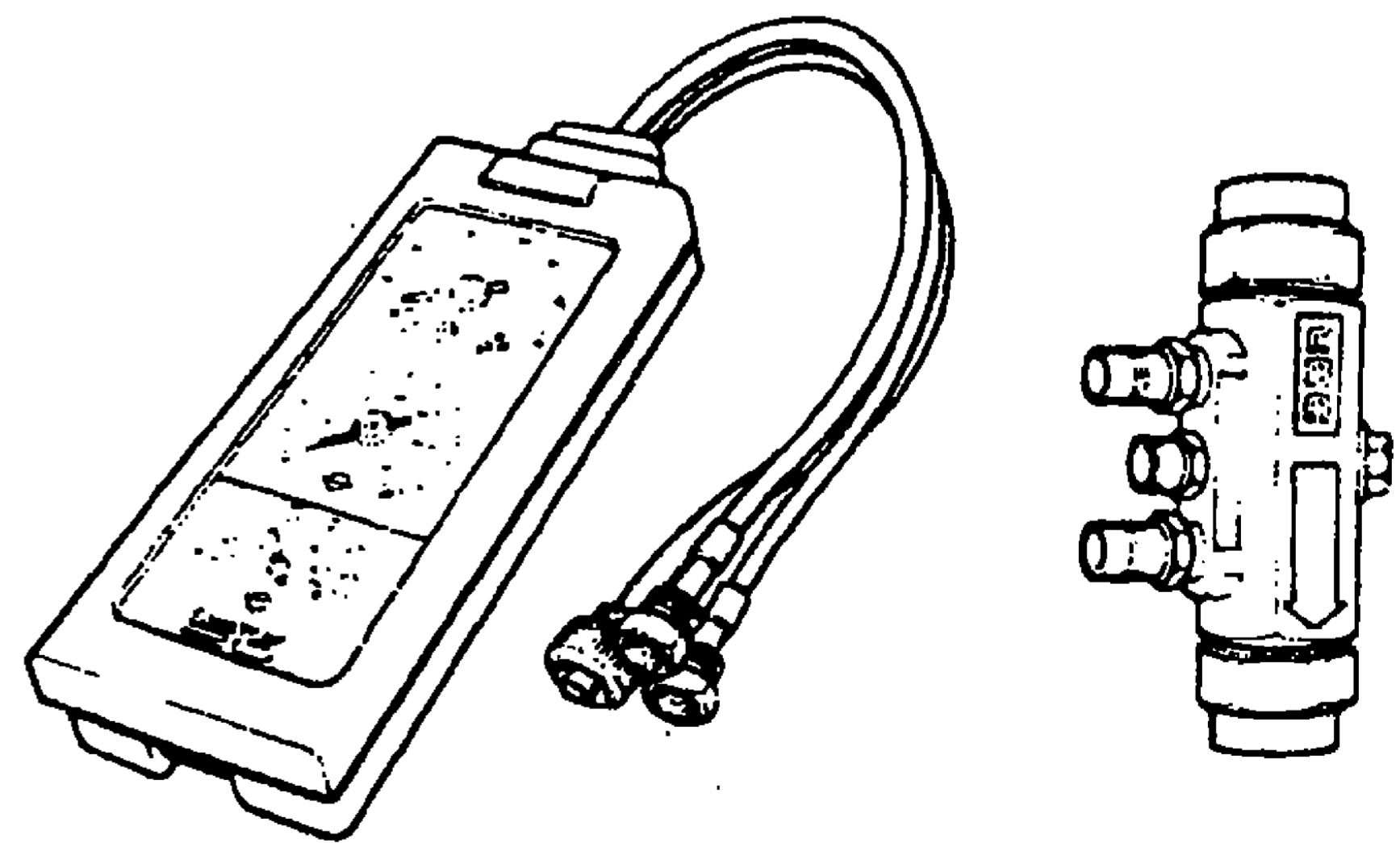

S188150

Service Tools - Hydraulics (continued)

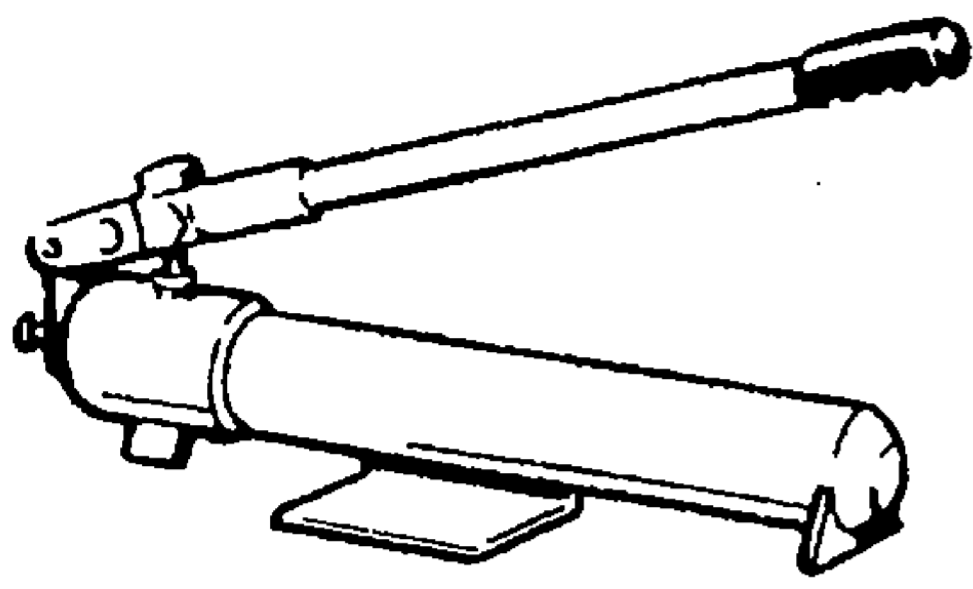

S193850

Hand Pump Equipment

- 892/00223 Hand Pump
- 892/00137 Micro-bore Hose $\frac{1}{4}$ in BSP x 3 metres
- 892/00274 Adapter $\frac{1}{4}$ in BSP male x $\frac{3}{8}$ BSPT male
- 892/00262 Test Point on $\frac{1}{4}$ in BSP male x $\frac{1}{4}$ BSP female adapter
- 892/00706 Test Probe
- 892/00278 Gauge 0-40 bar (0-600 lbf/in²)
- 892/00279 Gauge 0-400 bar (0-6000 lbf/in²)

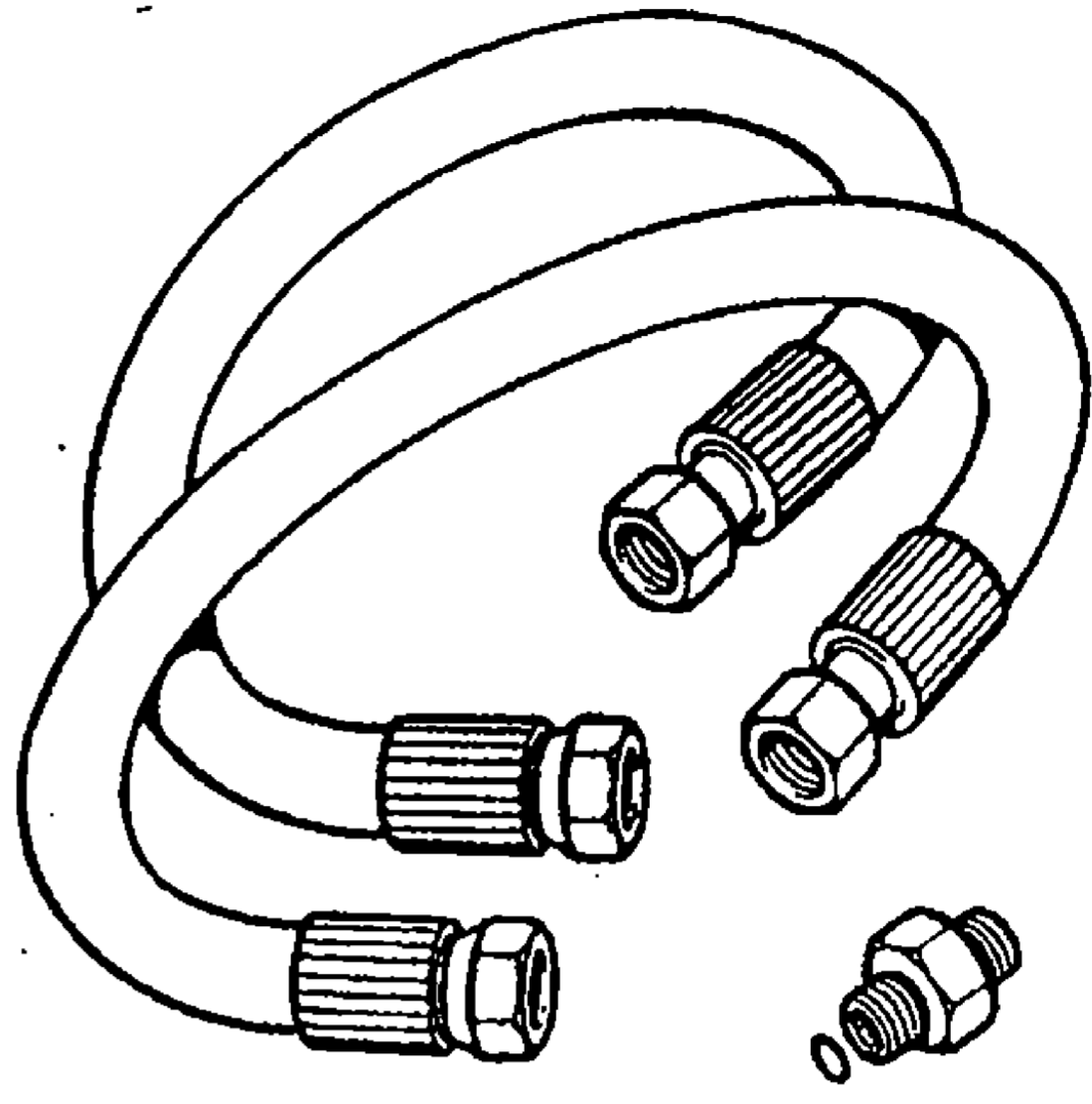

197210

892/00318 Hose And Adapter Kit
To enable flow and pressure test equipment to be connected to adapters fitted with 'O' ring face seals.

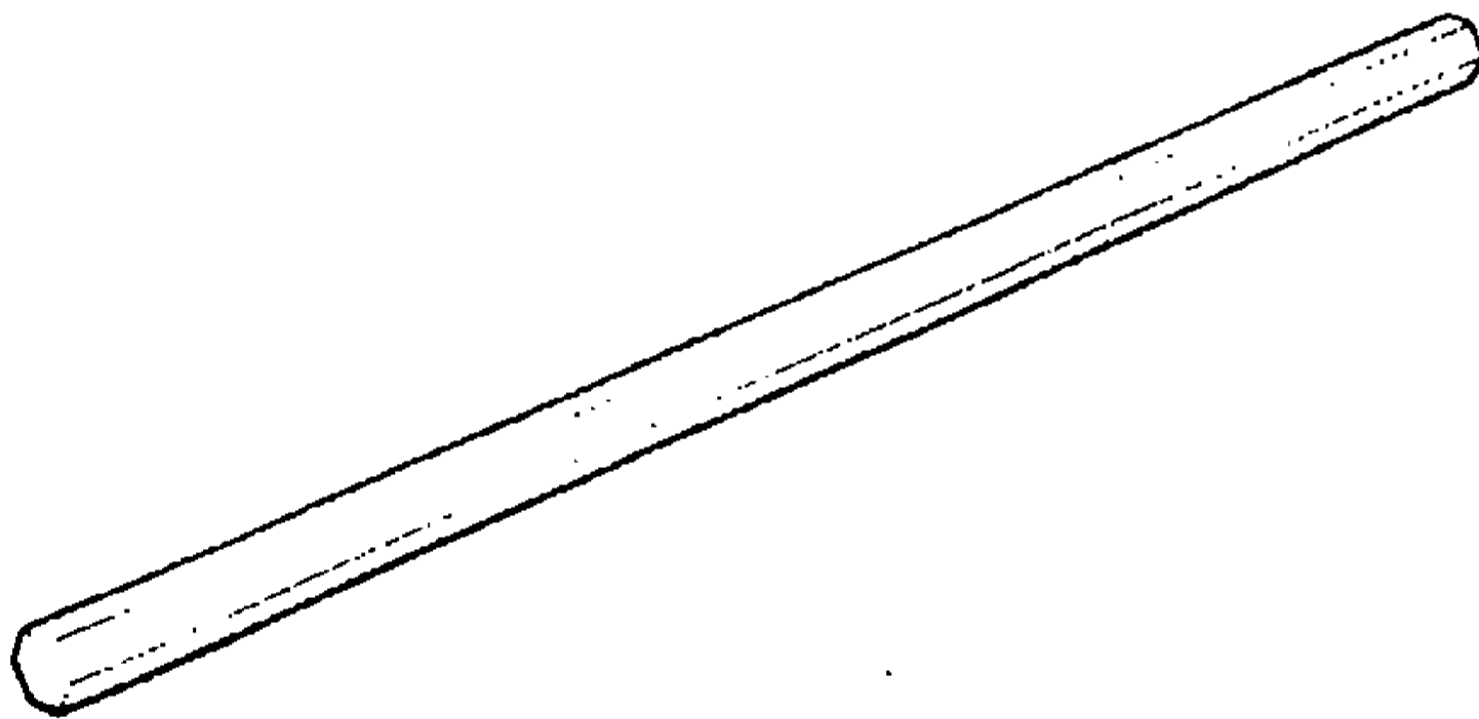

197230

892/00316 Hexagon Extension to reach the lower mounting capscrew on the transmission and external hydraulics pump. (prior to machine no. 636001)

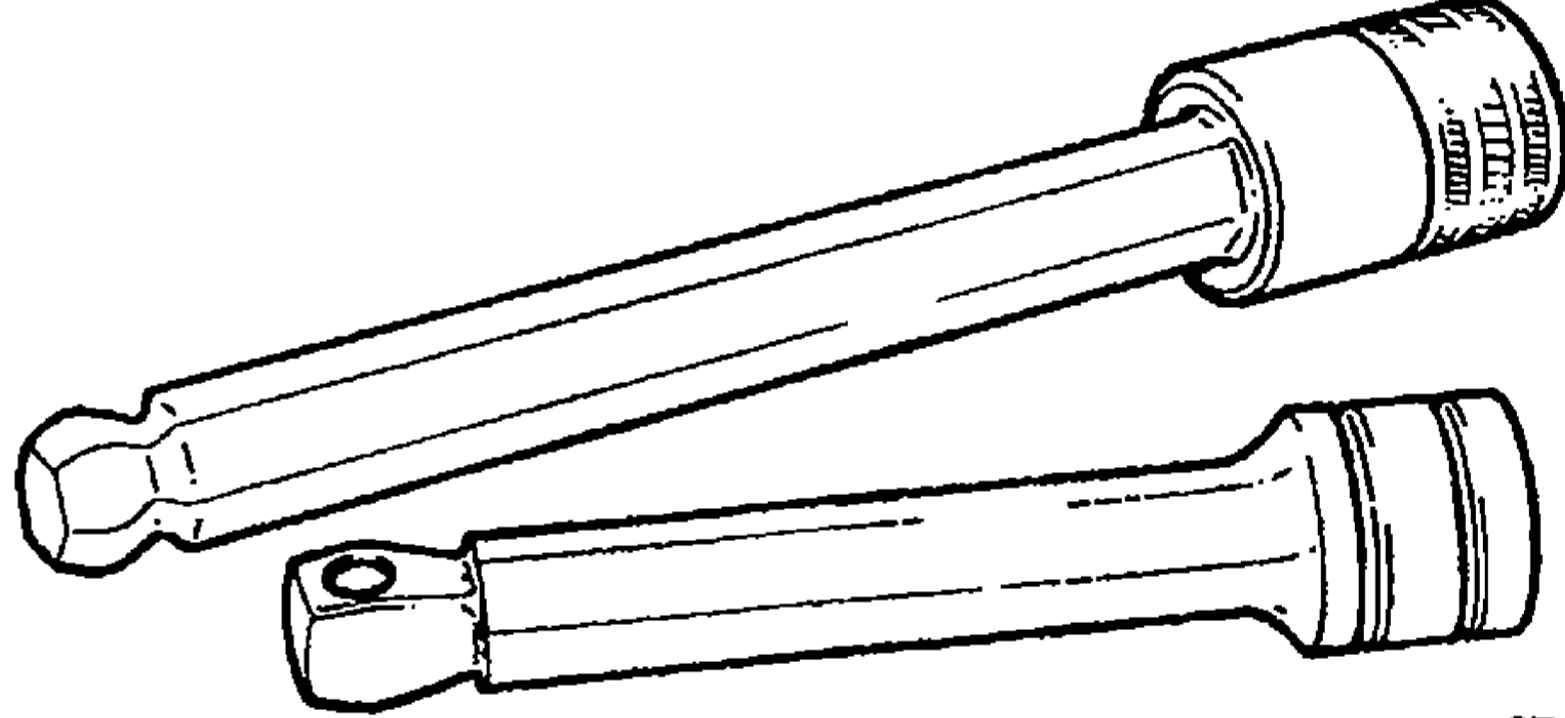

197190

Tools to reach the lower mounting capscrew on the transmission and external hydraulics pump. (These suit all machines before and after serial no. 636001.)

- 10 mm Ball End Allen Key Part no. FABLM10
- 60 mm Wobble Drive Extension Part no. FXW11A

Obtain from Snap-on suppliers

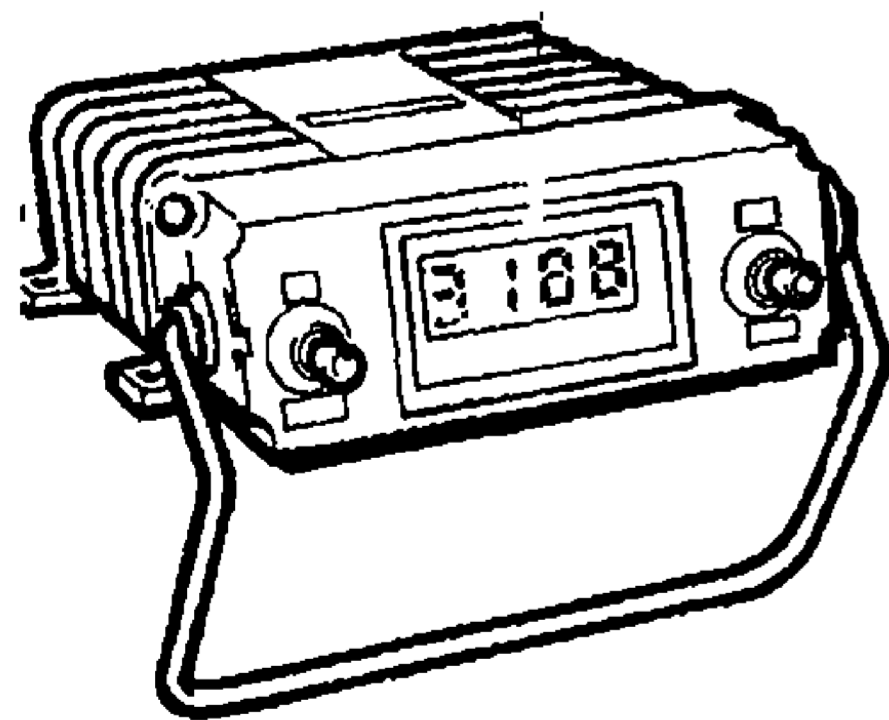

S191580A

892/00317 Diagnostic Test Box for Electronic Draft Control

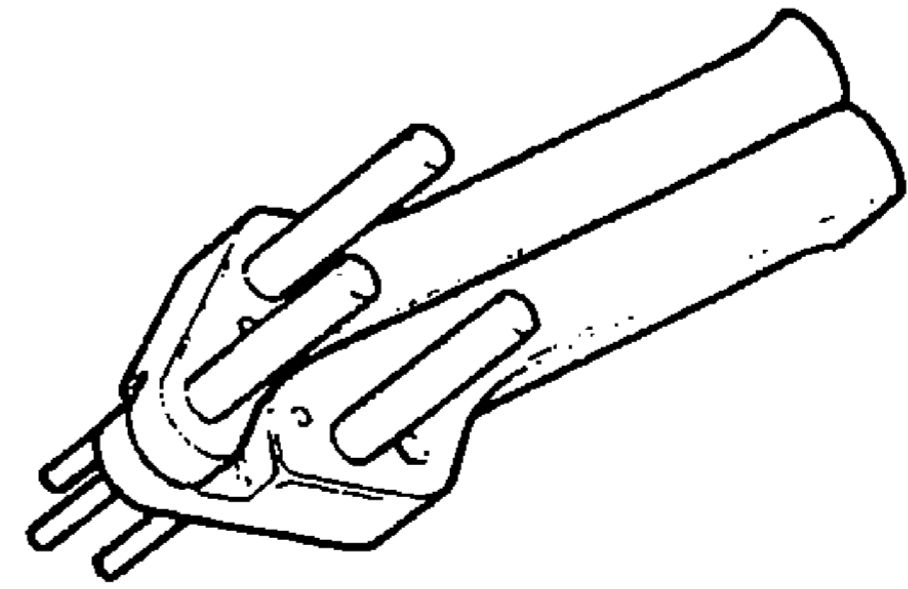

197220

892/00334 Gland Seal Fitting Tool

Service Tools (cont'd)

Section F - Transmission

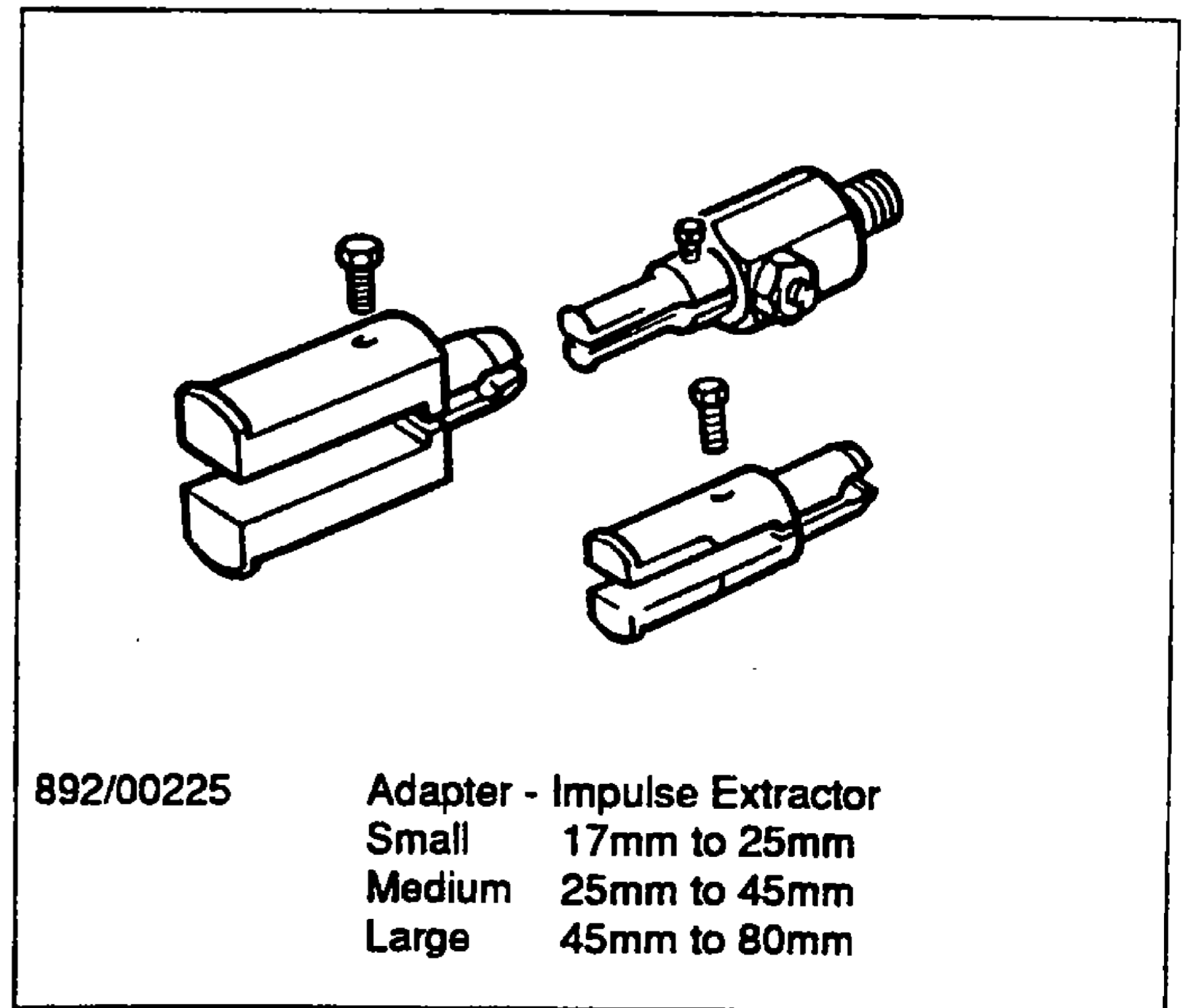
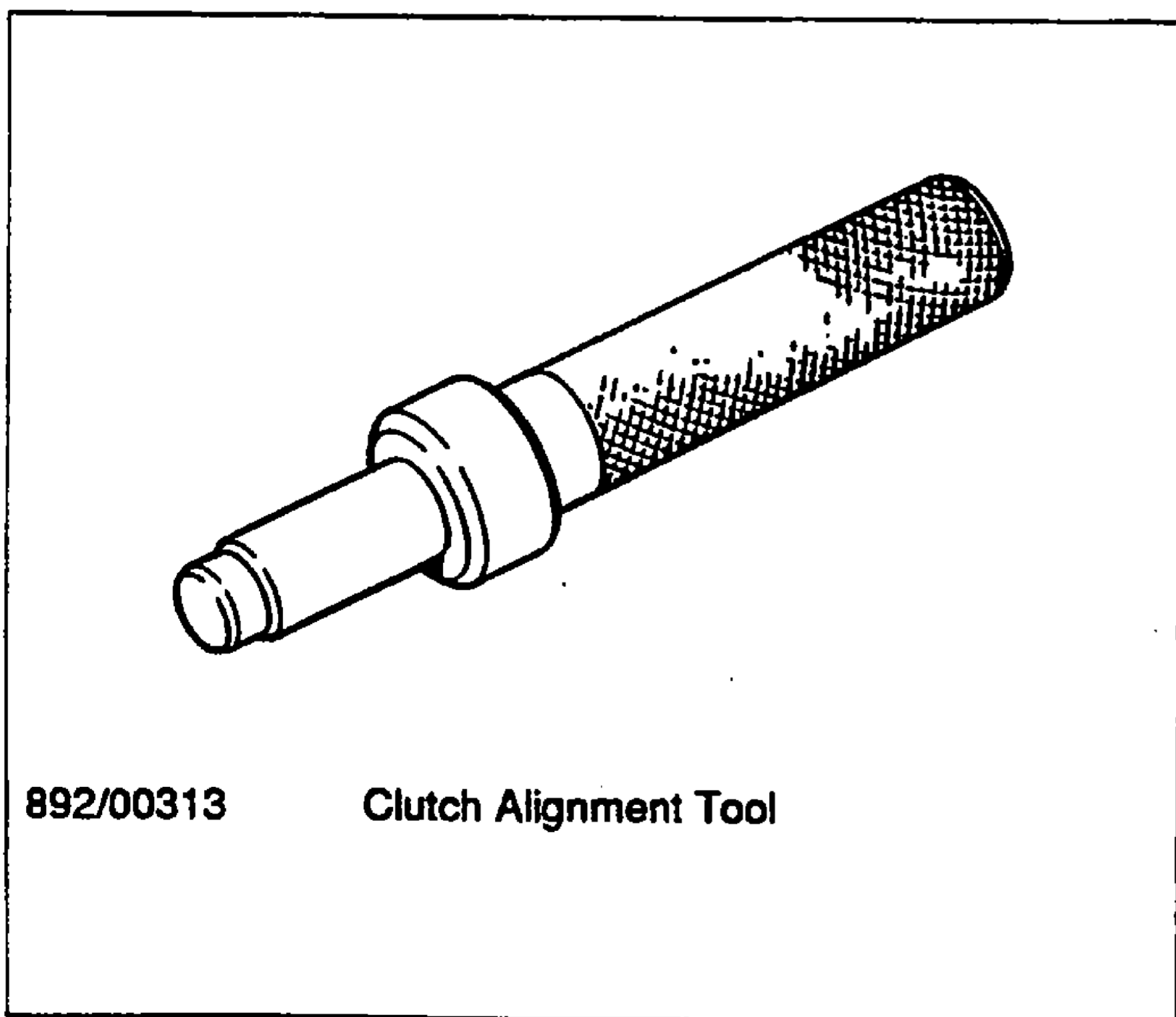
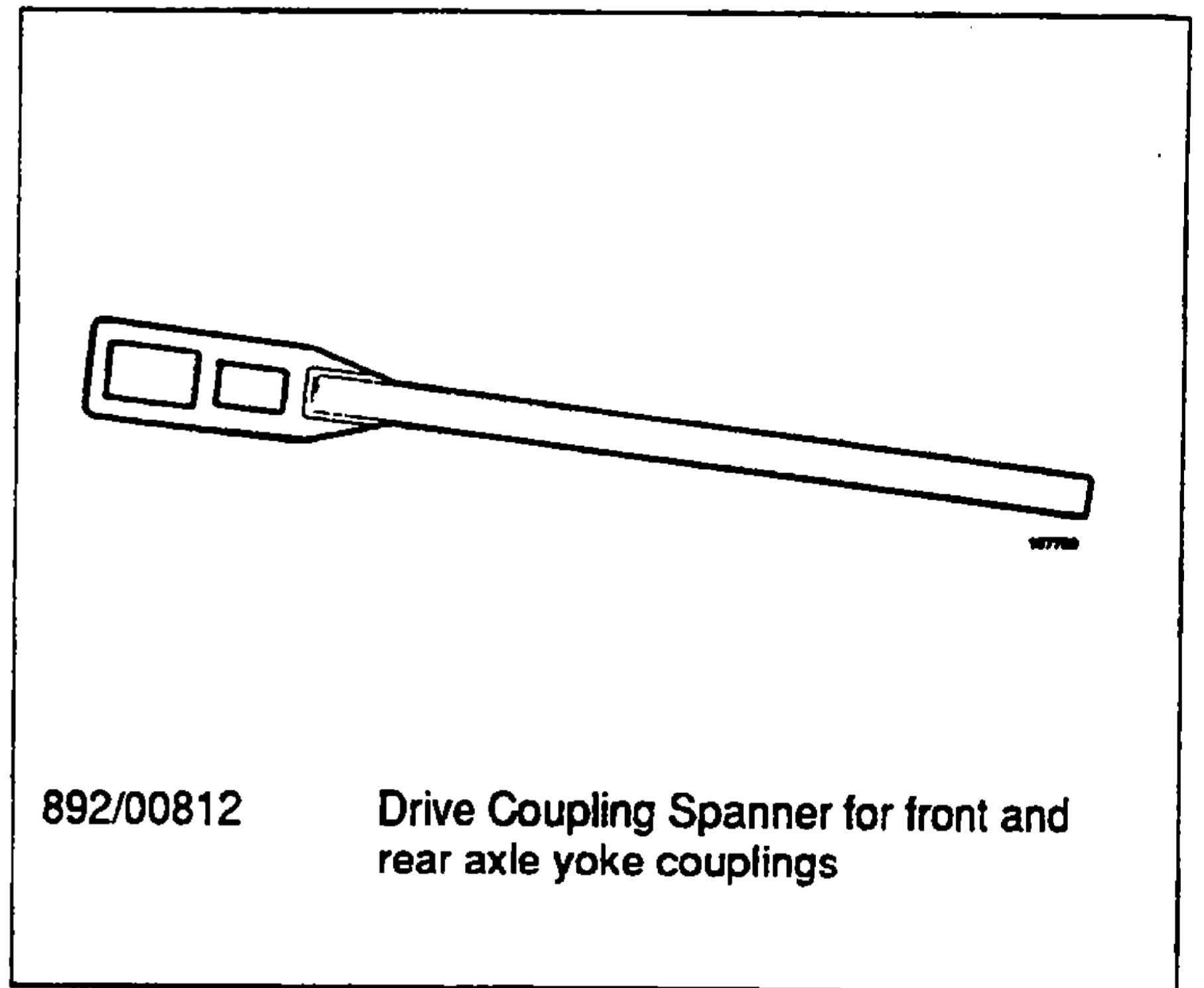
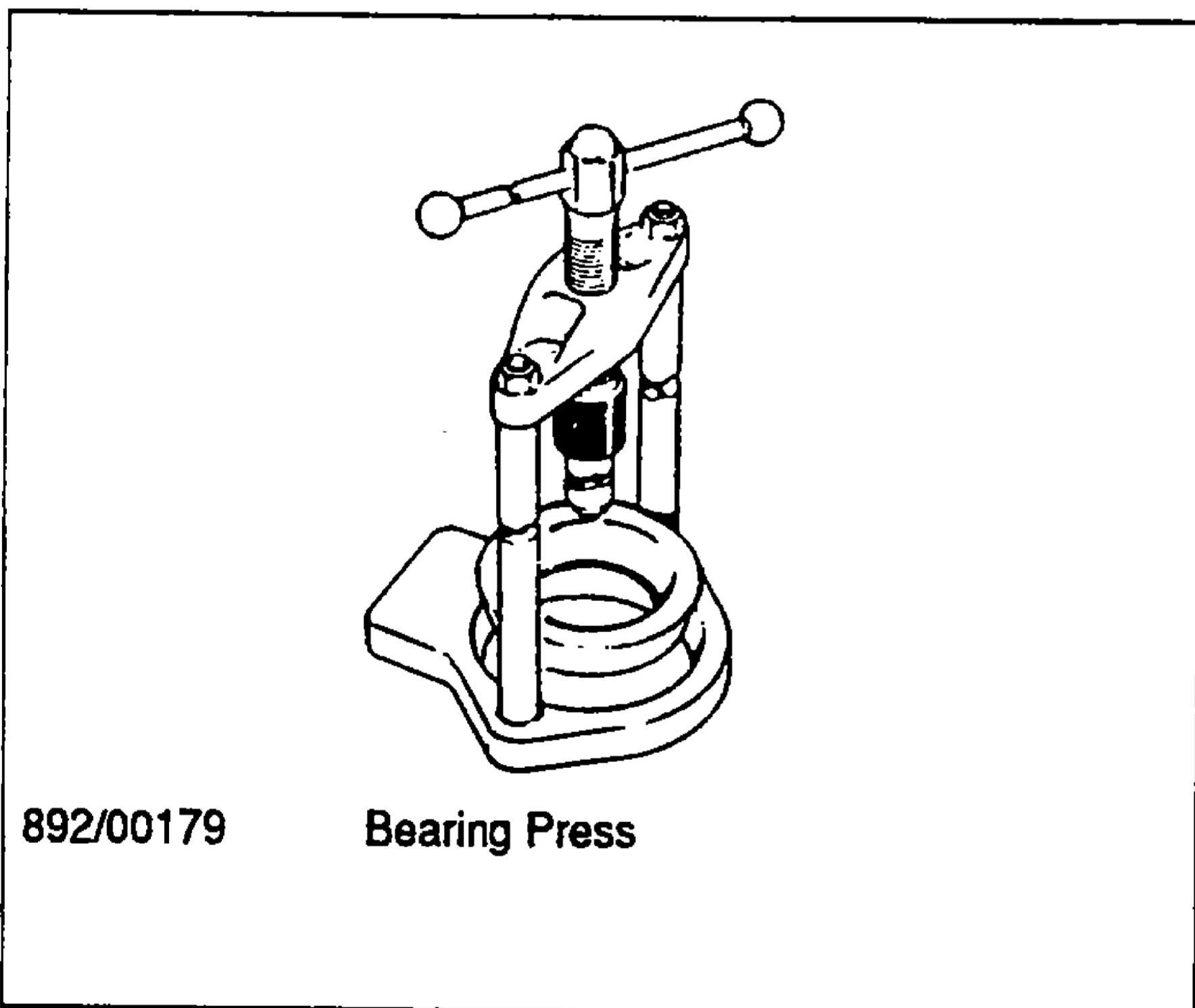
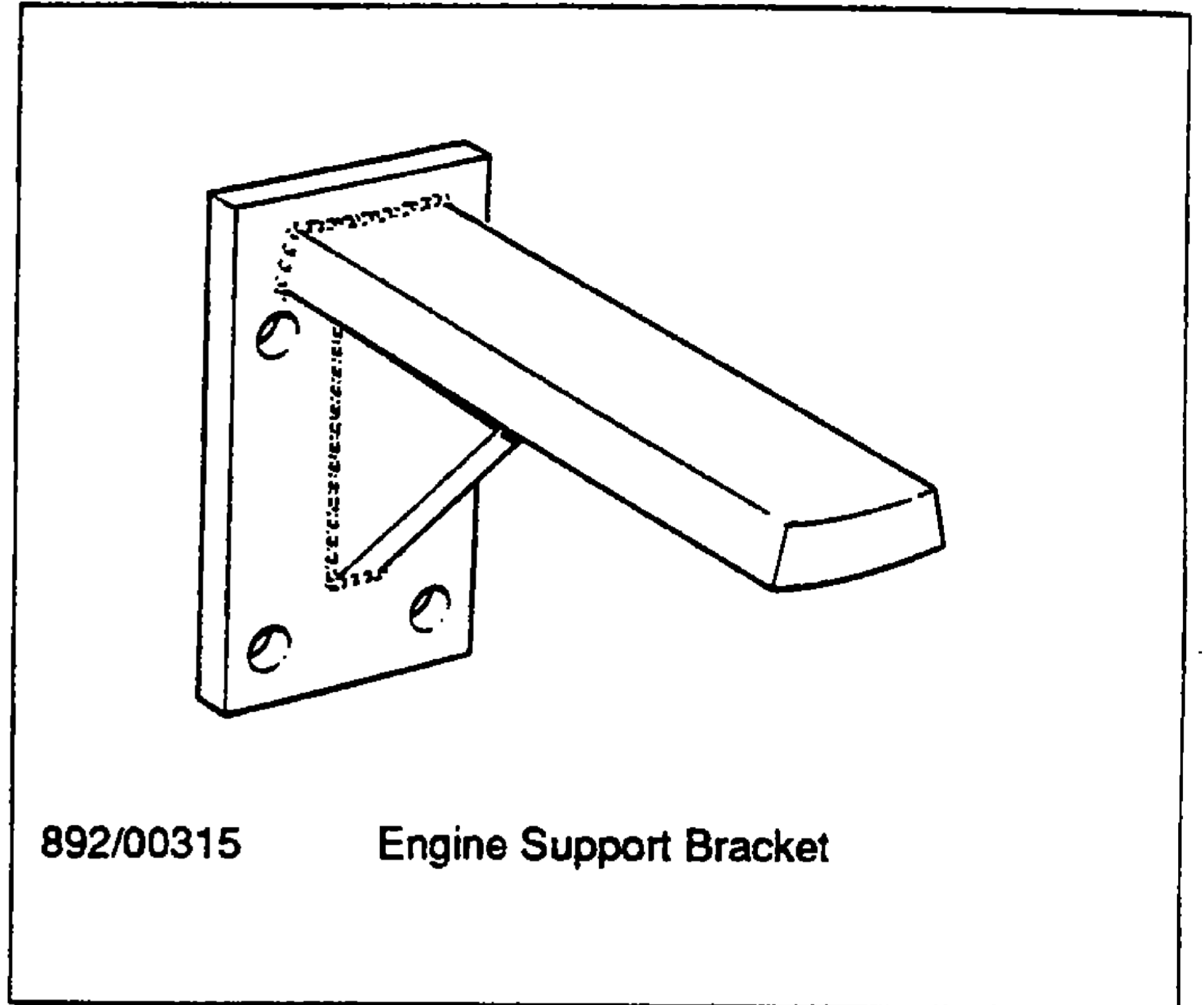
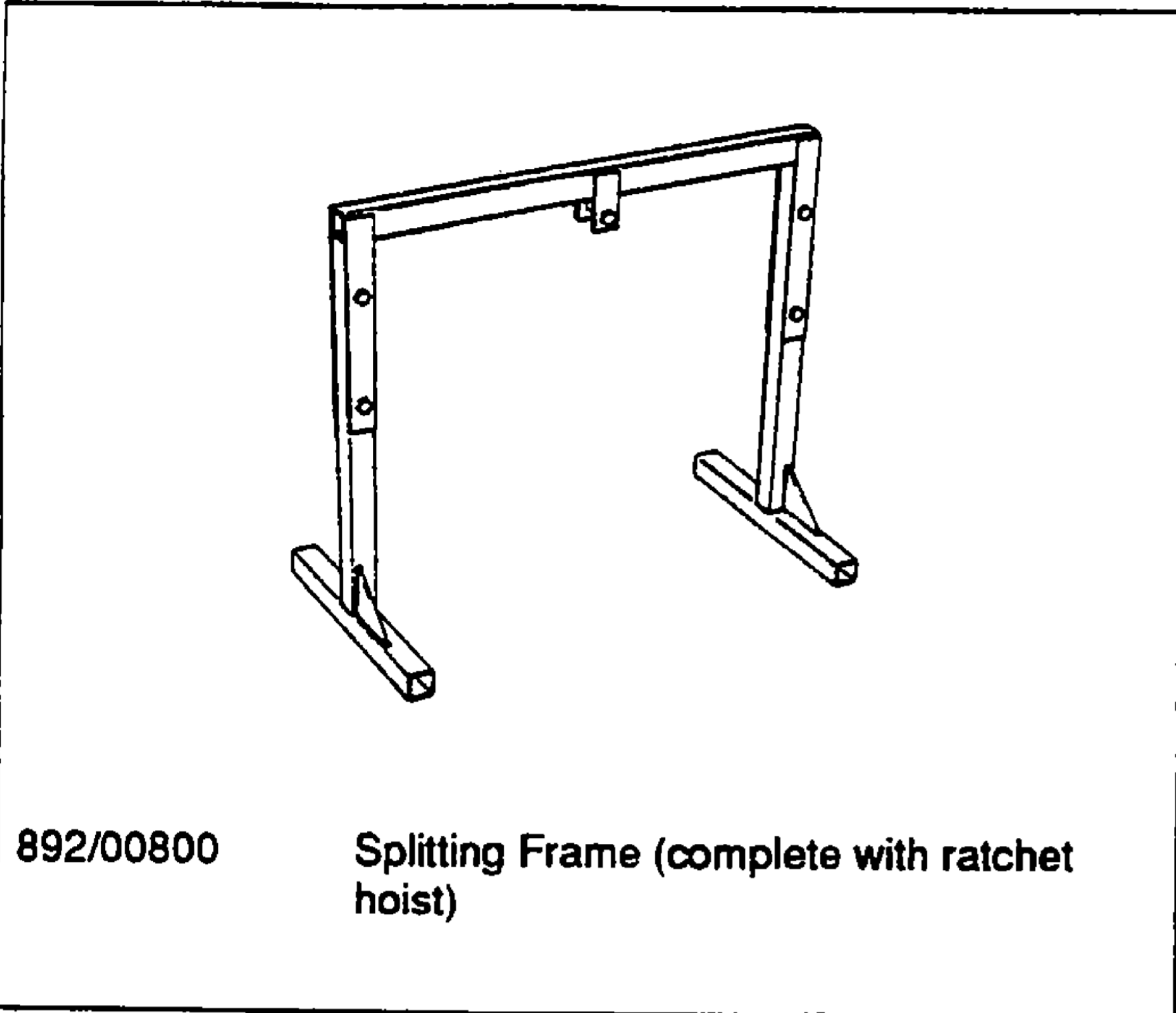

Service Tools (continued)

Section F - Transmission

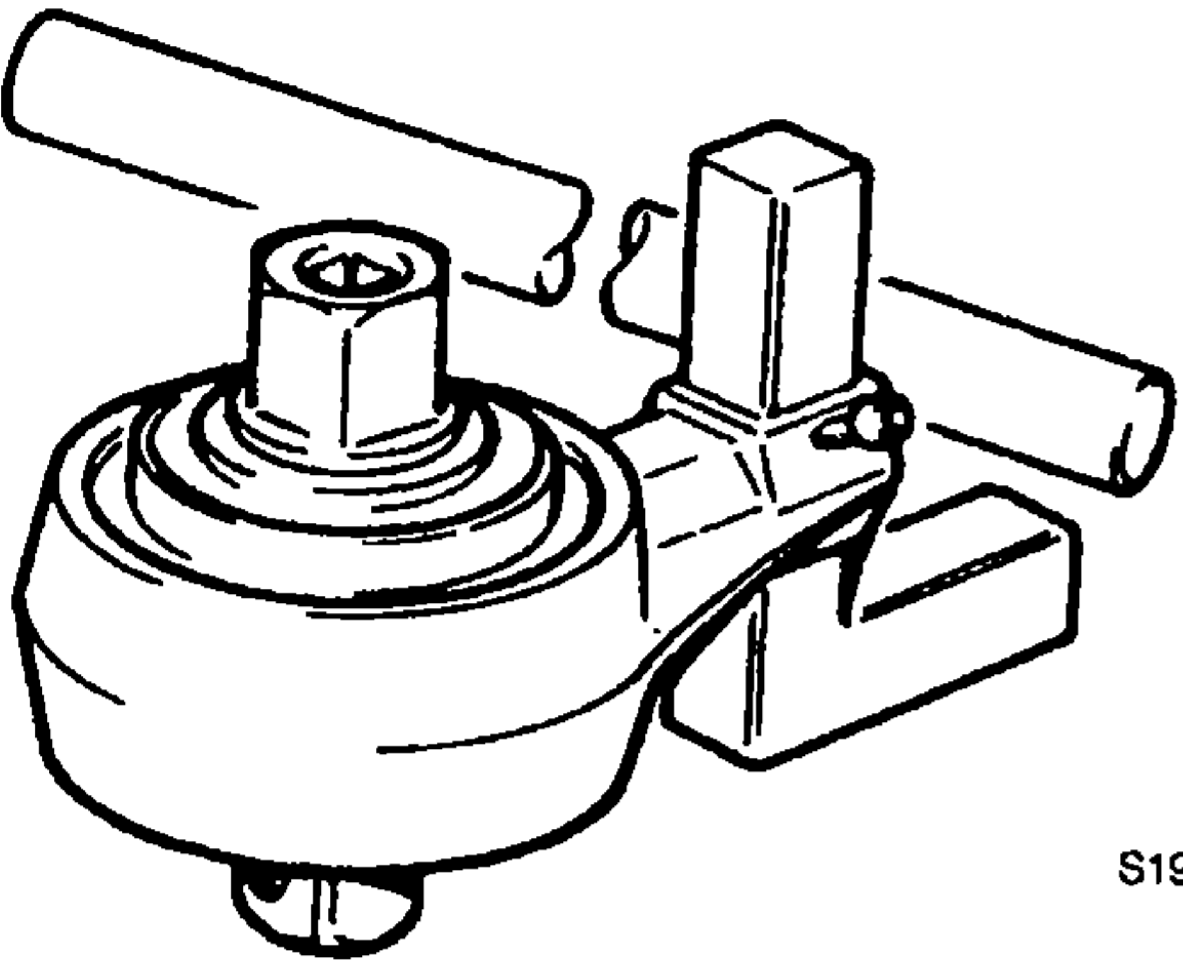

993/45400 Torque Multiplier
(use in conjunction with a torque wrench to give a 5 : 1 multiplication)

S197030



* Heavy Duty Sockets 197250

892/00817	17 mm A/F x 3/4in. square drive
892/00818	22 mm A/F x 3/4in. square drive
892/00819	15 mm A/F x 1/2in. square drive
892/00333	19 mm A/F x 3/4in. square drive

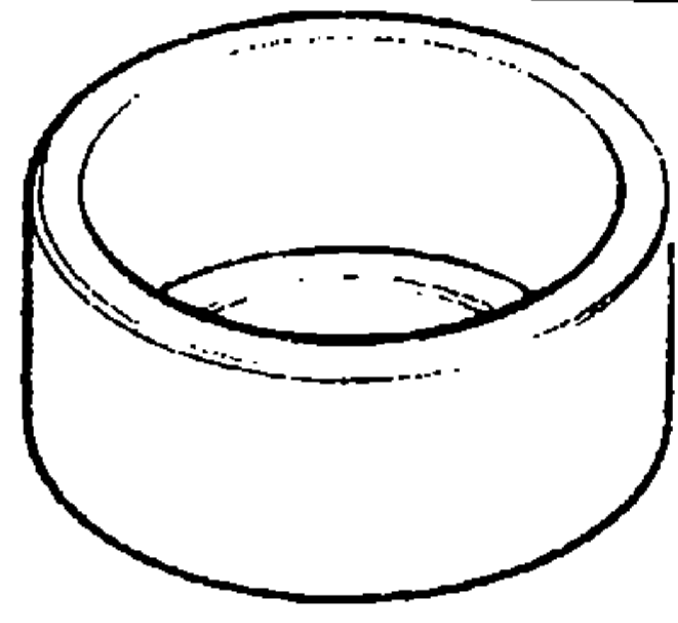

892/00174 Measuring Cup - Pinion Head Bearing

S190770

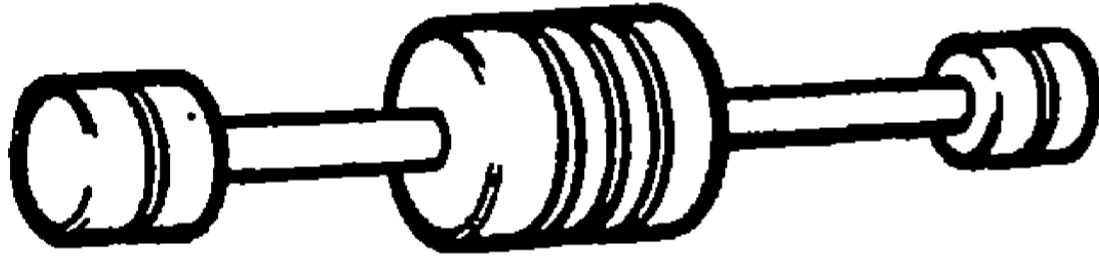

892/00224 Impulse Extractor Set for Hub Bearing Seals

S197070

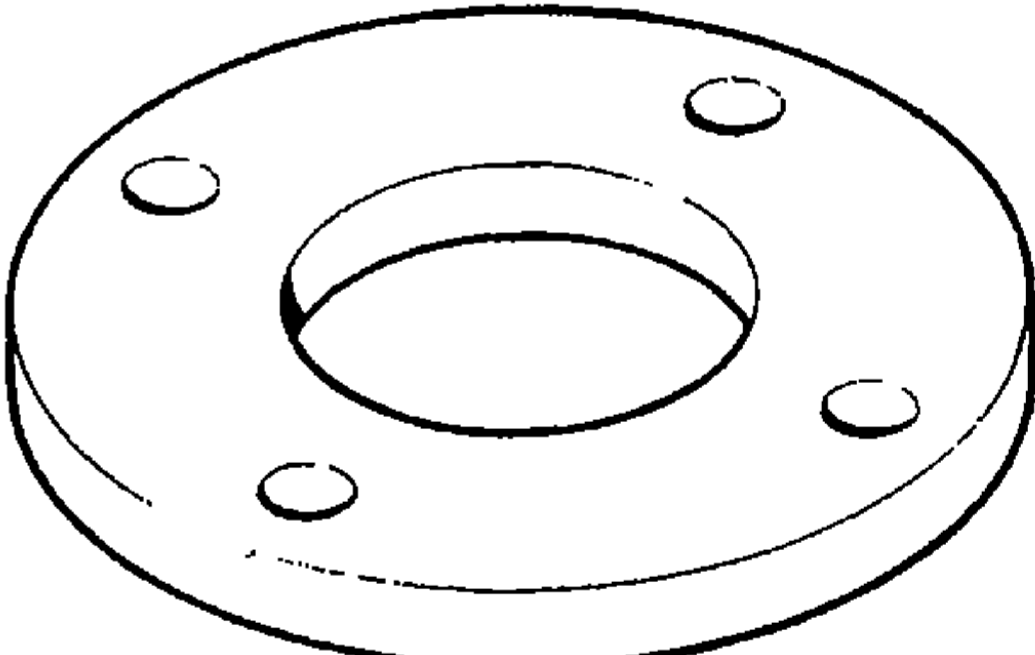

892/00312 Dummy End Plate for Range Gearbox

S197240

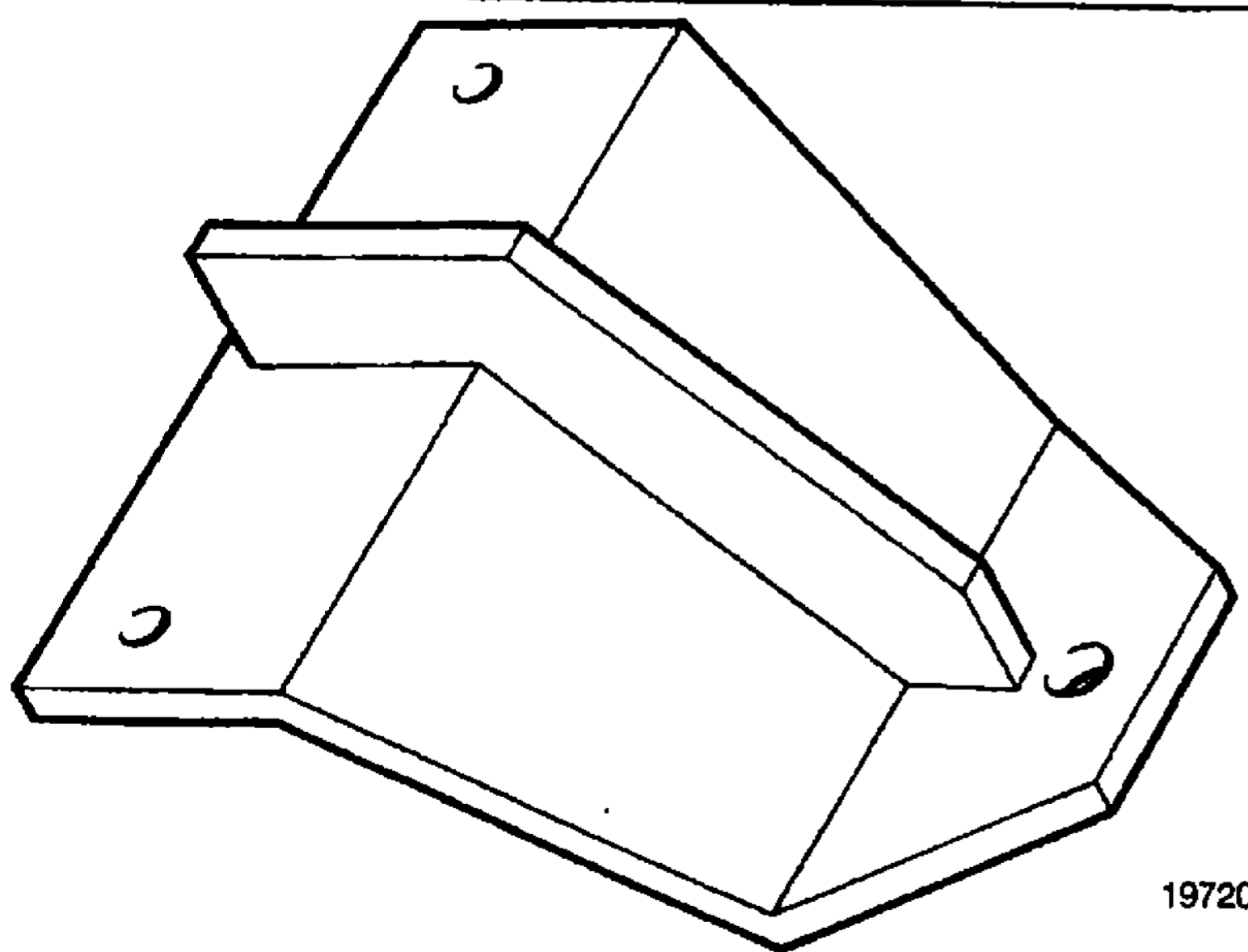

477/00437 Gearbox Lifting Adapter (from machine no. 636001)

197200

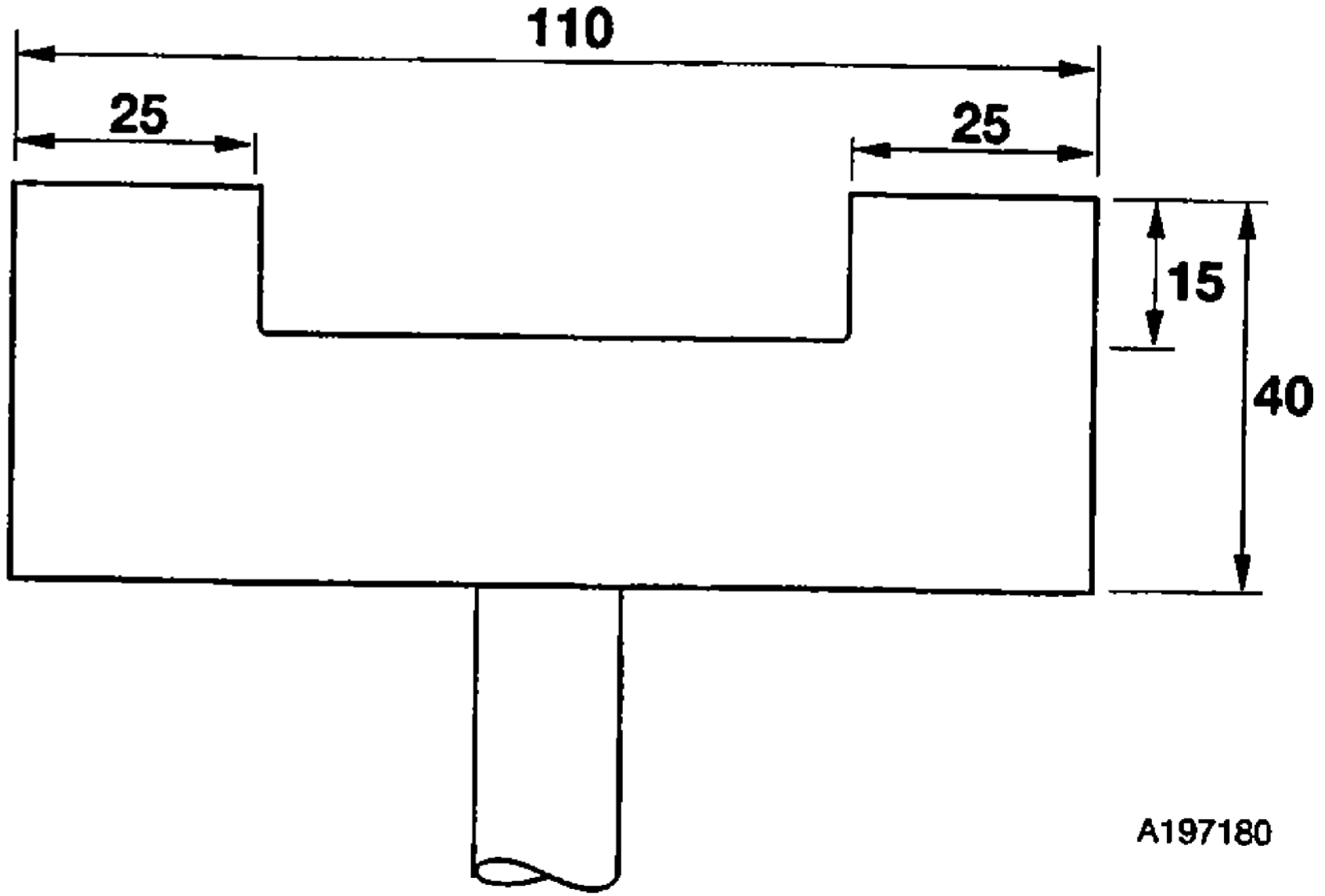

110
25 25
15
40

A197180

Rear Differential Setting Key (from machine no. 636001)
Cut from 5 mm plate to dimensions shown. Fabricate handle to suit.

Service Tools (continued)

Section F - Transmission (continued)

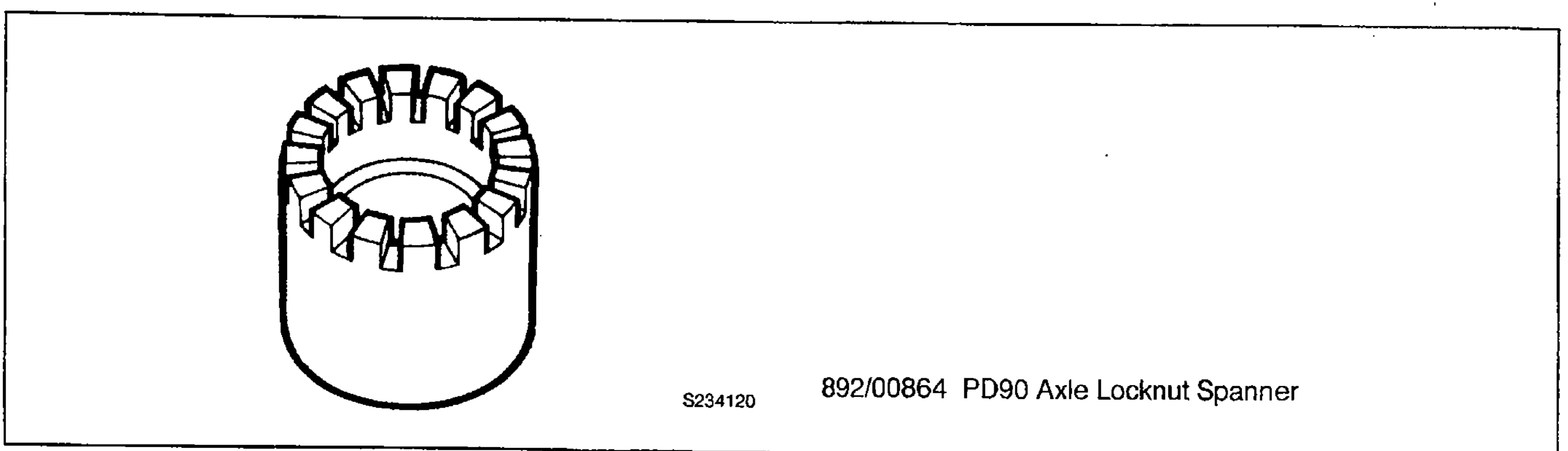
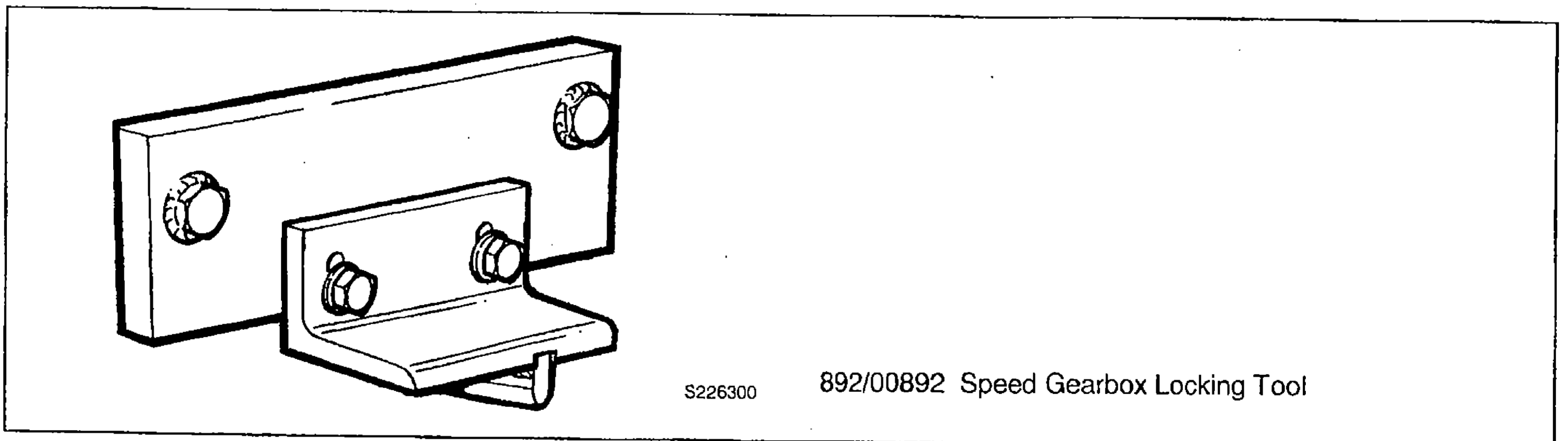
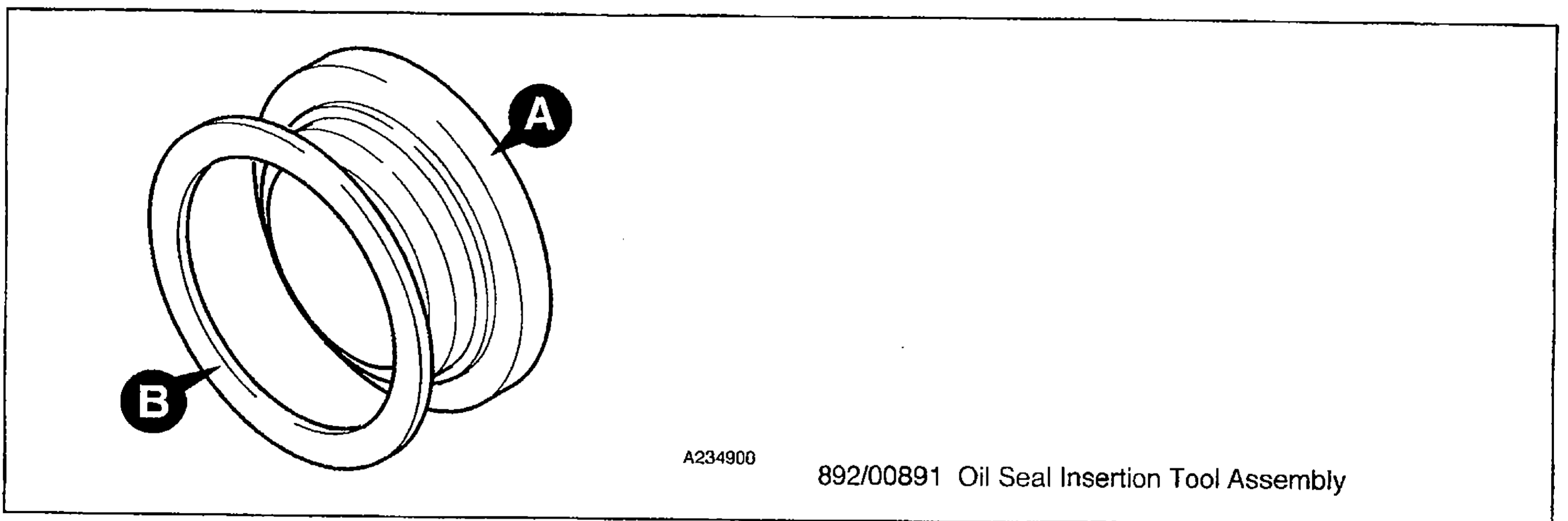
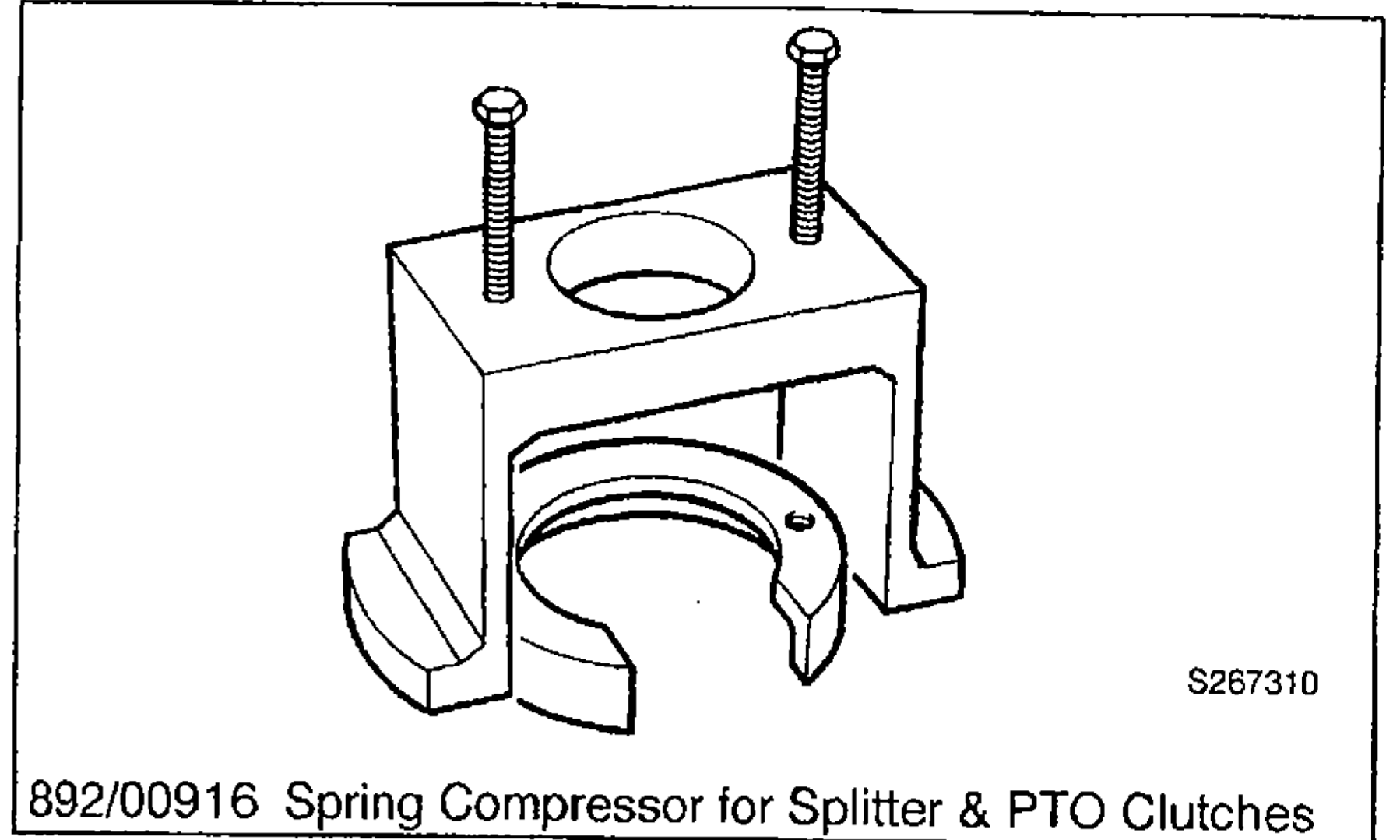
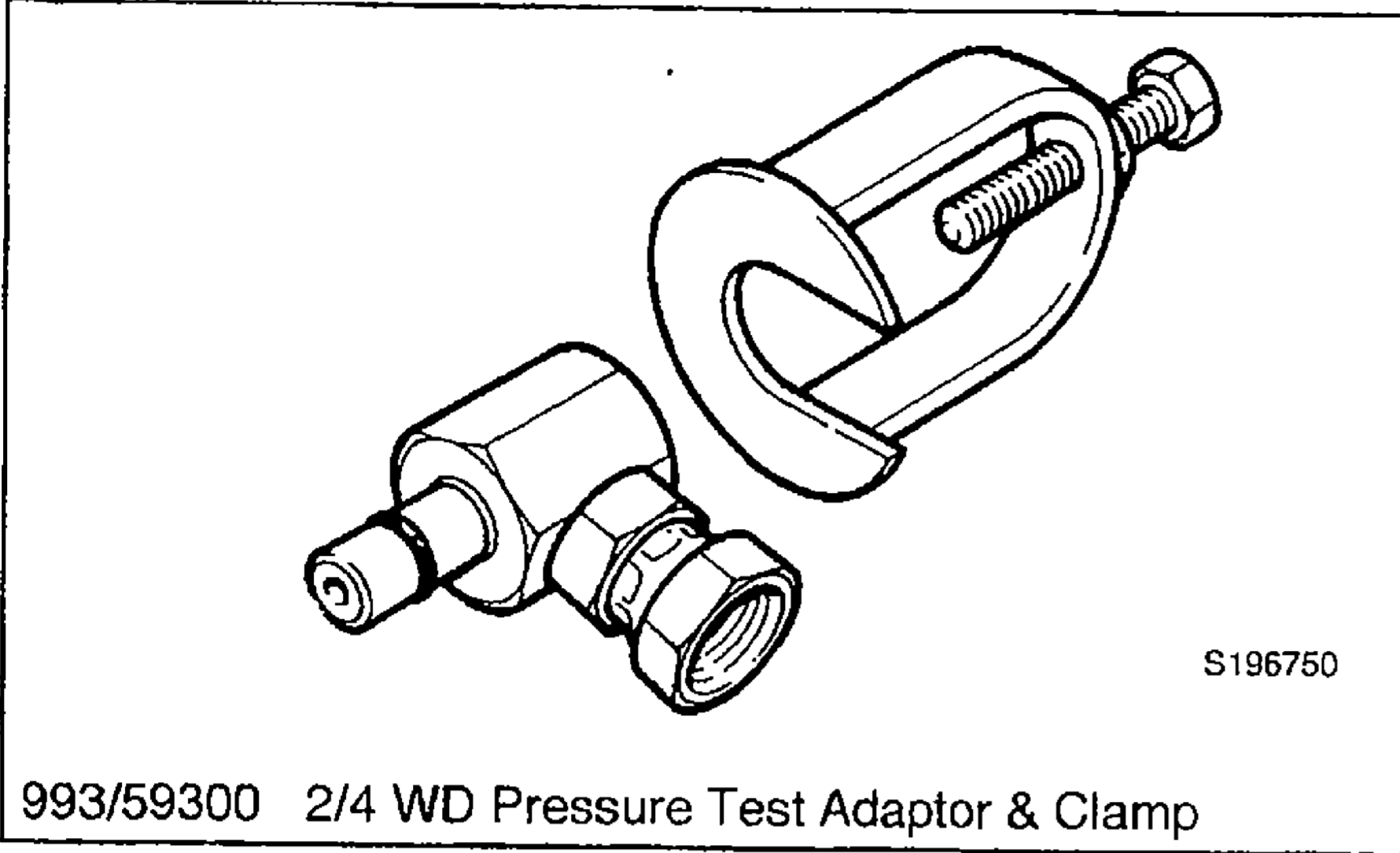

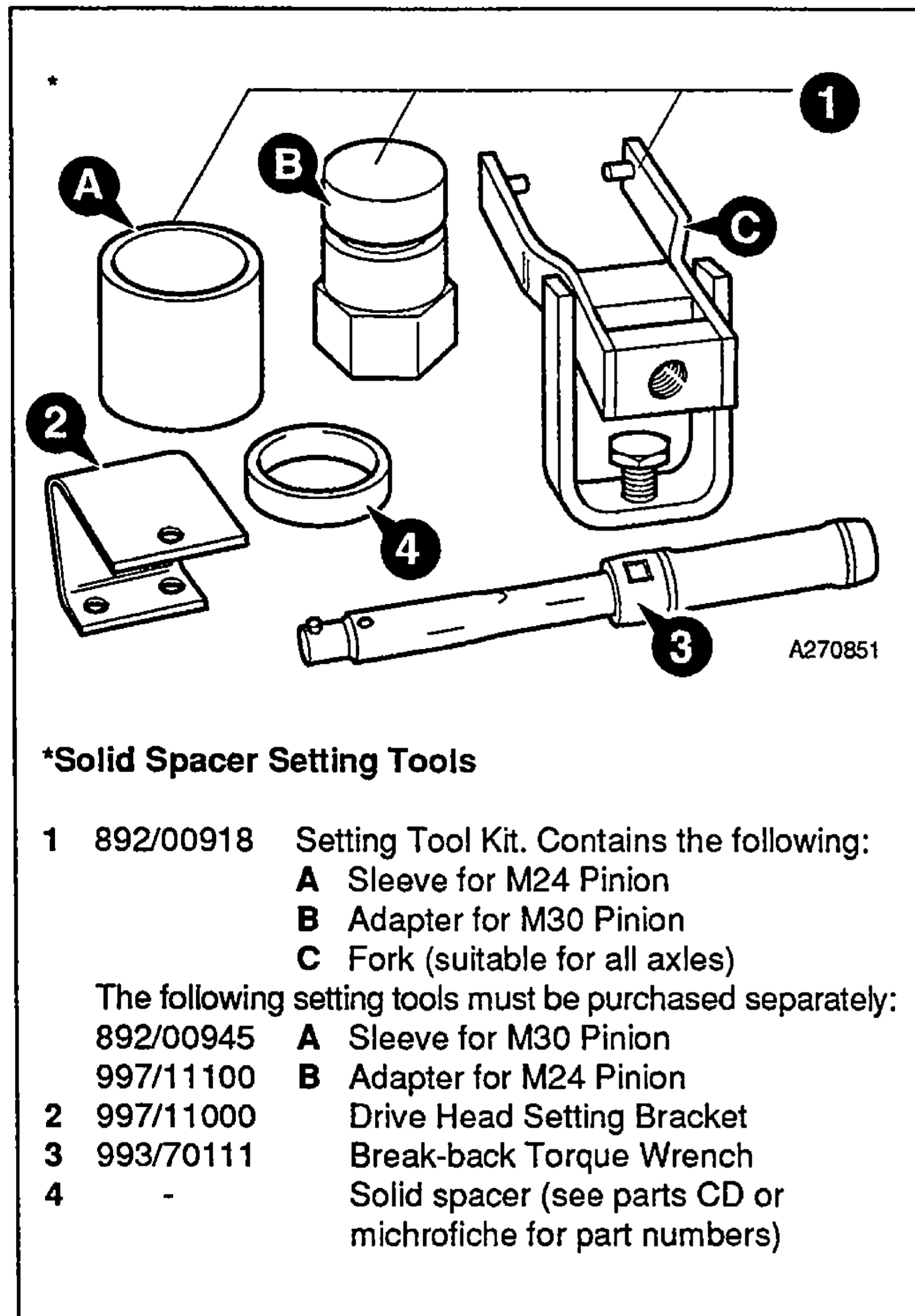
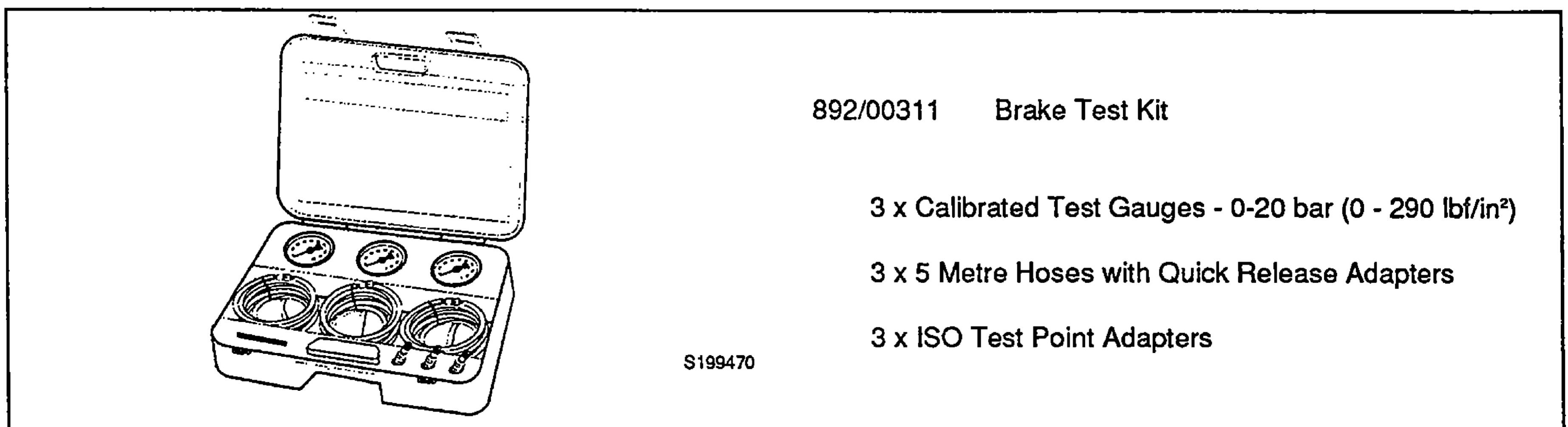
Service Tools (continued)**Section F - Transmission (continued)****Section G - Brakes**

Service Tools (continued)

Section H - Steering

Puller adapter assembly for removal of drop arm from steering box from machine no. 636372. Comprises:

A	892/00871	Frame	1 off
B	892/00874	Brace	1 off
C	892/00875	Bar M24	2 off
D	892/00876	Block	2 off
E	1370/0901Z	Nut M24	2 off

Use in conjunction with a 20 tonne hydraulic ram as obtainable from Sykes Pickavant to suit puller bars at 185 mm centres.

222490

Spanners for input shaft nuts on steering box from machine no. 636372.

* F	892/00884	'C' Spanner
G	892/00883	Spanner

220130

Section S - Suspension

S199480

892/00314 Accumulator and Gas Spring Pressure Test Adapter

Section T - Engine

892/00041 De-glazing Tool for Cylinder Bores (to assist bedding-in of new piston rings)

Note: For other engine tools refer to the relevant Engine Service Manual.

S192390

General

Do not tow a machine unless there is no alternative. Remember that more damage might be caused to the machine by towing it. If at all possible repair the machine where it stands.

Note: It is not possible to tow-start a machine fitted with JCB Powersplit.

Make sure you will be obeying all pertinent laws and regulations before towing the machine on public roads.

⚠ DANGER

If the engine is not running, there will not be enough air to apply the service brakes or release the parking brake. Carefully follow the precautions in this section before moving the machine or there may be a serious accident.

13-2-2-6/1

⚠ CAUTION

Towing a machine too far or too fast can damage the transmission. Do not tow the machine further than one mile. Use a trailer for greater distances. When towing do not travel faster than 25 km/h (15 mph).

Use a rigid drawbar. If you must use towing chains, then use two towing vehicles. One towing vehicle should be coupled to the front of the disabled machine. The other towing vehicle should be coupled to the rear of the disabled machine, to provide braking power.

The towing vehicle(s) must have enough pulling and braking power to move and stop the machine.

2-2-7-3

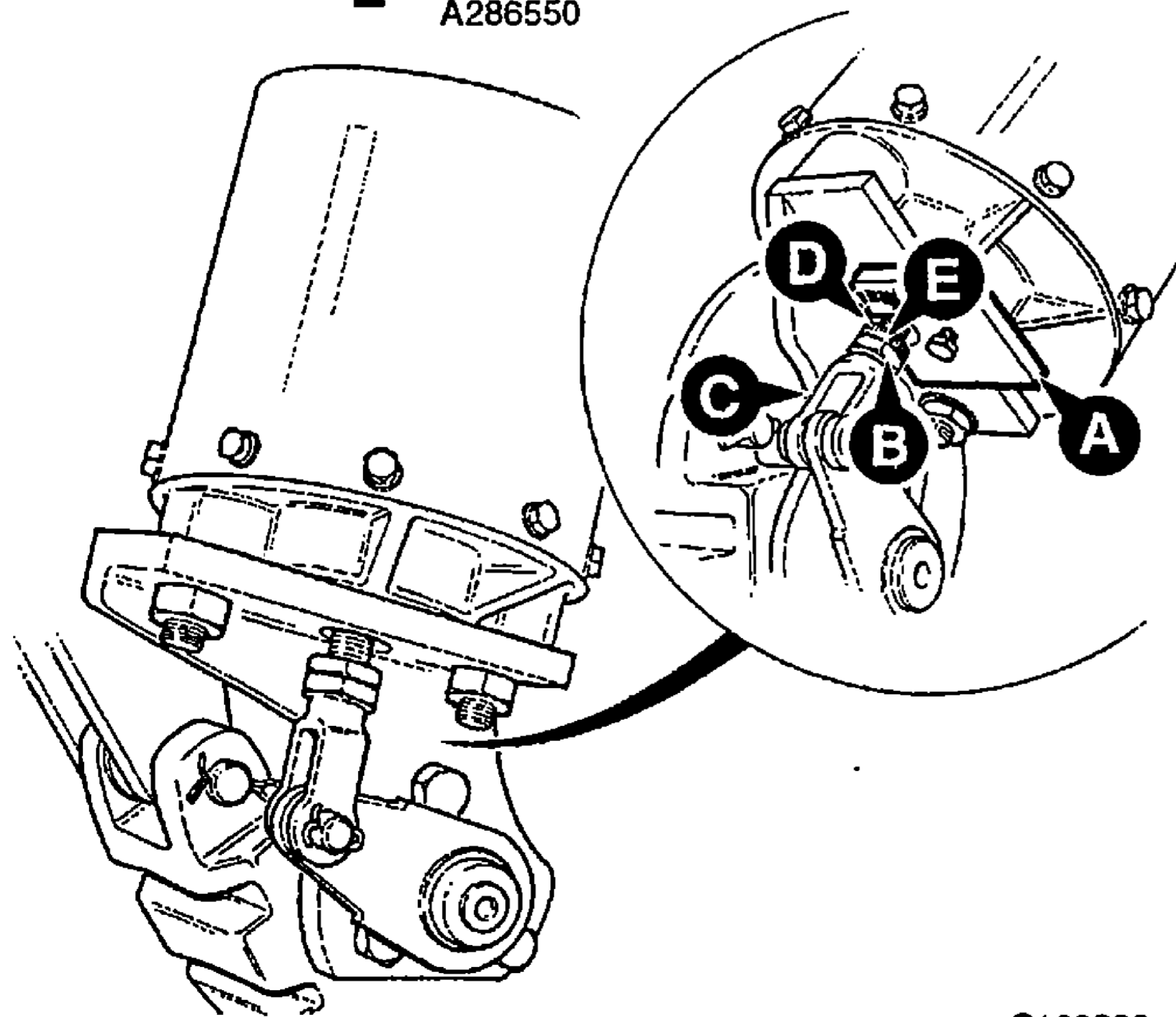
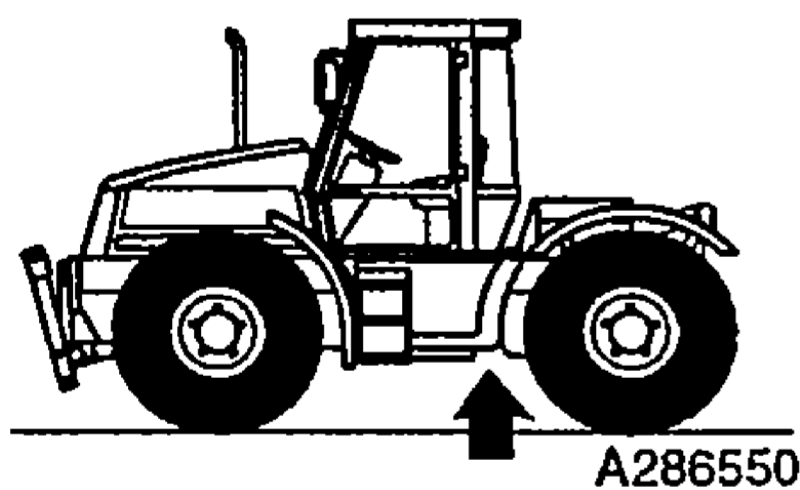

S160392

Preparation for Towing

- 1 **Connect the towing vehicle.**
 - a Apply the parking brakes on the towing vehicle and securely chock the wheels on the Fastrac.
 - b Fit the drawbar between towing vehicle and Fastrac.
- 2 **Prepare the machine.**
 - a Make sure that the range and speed gearboxes are both in neutral.
 - b If the gearbox has failed, disconnect both propshafts (see Section F).
 - c If an axle has failed, remove the sun gears (see Section F).
- 3 **Release the Fastrac parking brake.**

If there is not enough air pressure to release the brake, start the engine to charge up the air system. If the engine cannot be run but the brake air system is serviceable, charge the system to 120 psi (8 bar) through Schrader valve X. This job must be done by a qualified mechanic, using the correct equipment.

⚠ DANGER

Ensure that the chocks and towing vehicle will prevent the Fastrac from moving as it is necessary to work under the machine to release the parking brake. When the parking brake has been manually released as described below, it will be impossible to apply the brake until plate A has been removed.

13-2-2-11

Alternatively, position plate A (if provided with the machine) as shown. Keeping nut B tight against clevis C, turn nut D against the plate so that rod E is drawn out of the actuator body and the parking brake is released.

Note: If the parking brake cannot be released, remove both propshafts (see Section F).

The machine is now ready for towing. If you will be steering the Fastrac, make sure you understand what the towing driver will be doing. Obey his instructions and all relevant regulations.

Remember that the steering will be much heavier if the engine is not running.

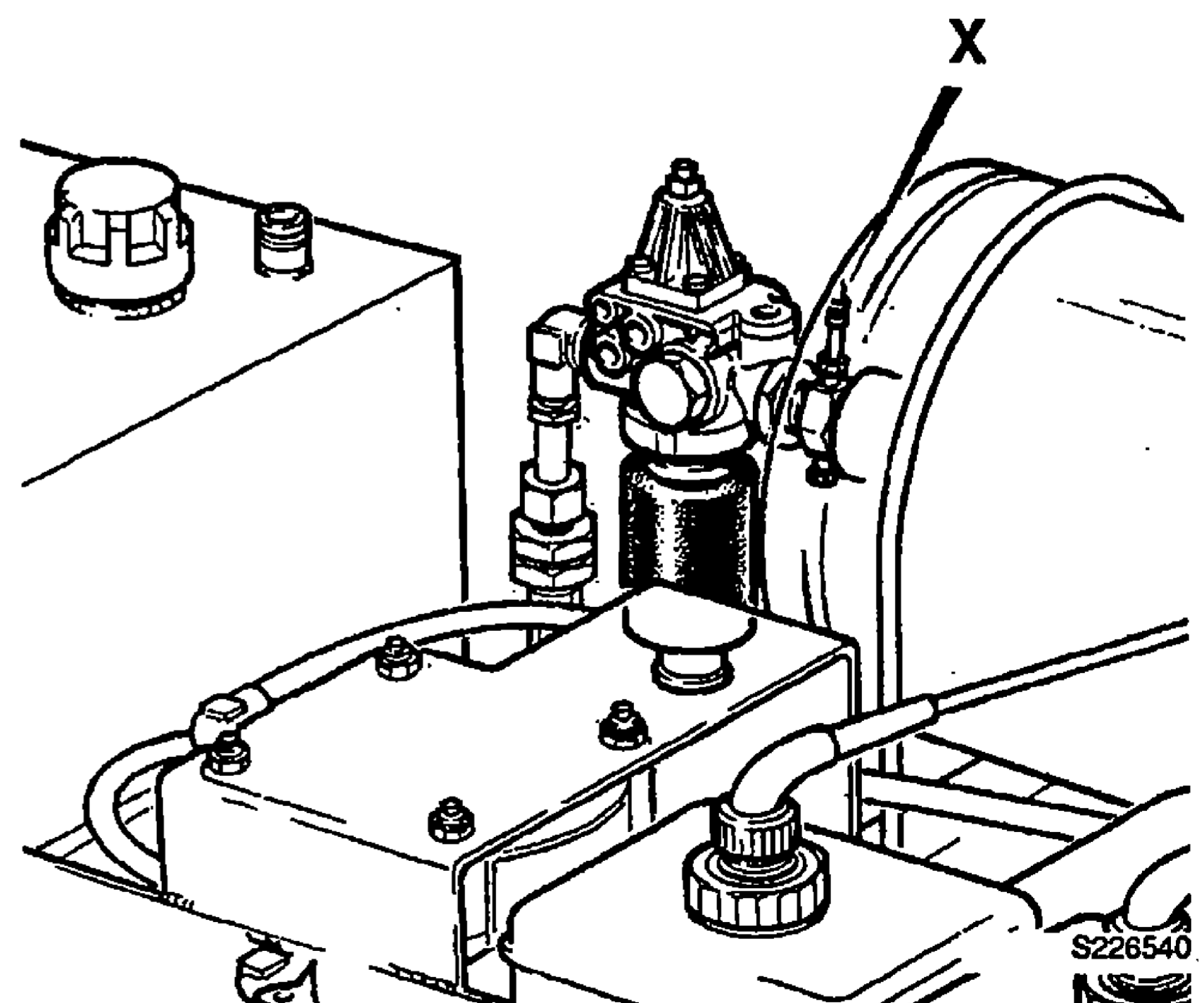

S226540

* Transporting the Machine

The safe transit of the load is the responsibility of the transport contractor and driver. Any machine, attachments or parts that may move during transit must be adequately secured.

5-2-5-9

Note: Before transporting the machine make sure you will be obeying the rules and laws of all the areas that the machine will be carried through.

Make sure that the transporting vehicle is suitable. See **Static Dimensions** (SPECIFICATIONS section in the machine handbook) for the dimensions of the machine.

WARNING

Before moving the machine onto the trailer, make sure that the trailer and ramp are free from oil, grease and ice. Remove oil, grease and ice from the machine tyres. Make sure the machine will not foul on the ramp angle. See Static Dimensions in SPECIFICATIONS section for the minimum ground clearance of your machine.

2-2-7-5/1

- 1 Place blocks at the front and rear of the trailer wheels.
- 2 Move the machine on to the trailer as follows:
 - a Make sure the ramps are correctly in place and secure.
 - b Carefully drive the machine onto the trailer.
 - c Set the drive to neutral and engage the parking brake.
 - d Switch off the engine.
 - e Ensure that the overall height of the load is within regulations.
 - f Secure the cab.

- 3 Anchor the machine to the trailer with chains or suitable webbing straps. The preferred fixing is to use webbing straps individually fixing all four wheels to the deck of the trailer as at **A**. If chains are used they should be connected to a suitable part of the drawbar at the rear of the machine. At the front, use the tie down points. Avoid chaining any part of the machine where the chains may damage critical componentry. For example, chaining around either axle provides the possibility of damaging the steel brake pipes running along their length.
- 4 Measure the maximum height of the machine from the ground. Try to make sure the truck driver knows the clearance height before he drives away.

